



Features

- Single Supply Voltage 2.7V to 4.8V
- Integrated 5GHz LNA With Bypass and SPDT

Applications

- IEEE802.11a WiFi Applications
- Consumer Electronics
- Mobile Devices
- Gaming
- General Purpose Switch and LNA Solution for 4.9GHz to 5.85GHz Frequency Range

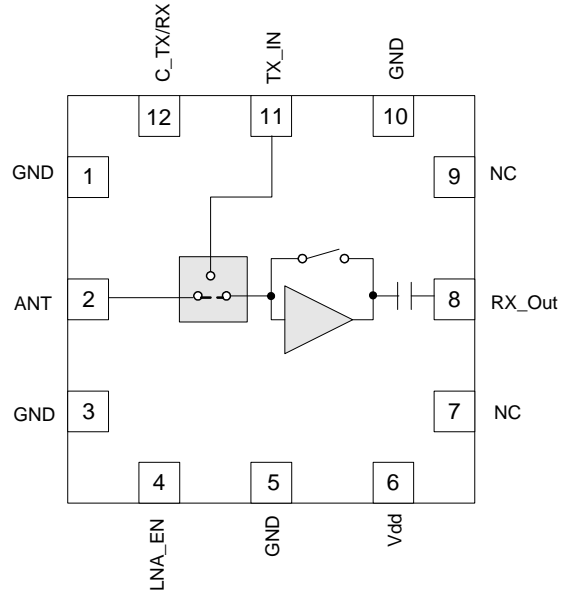

Functional Block Diagram

Product Description

The RF5540 is designed specifically for high-performance WiFi applications in the 5GHz ISM band. This module integrates the LNA with bypass and an SPDT switch of a Front End solution. The integrated input and output match reduces the number of external components keeping cost down and utilizing minimum layout area for implementation. The RF5540 is provided in a 2mmx2mmx0.5mm, 12-pin QFN package. This LNA + Switch front-end solution meets or exceeds the specification requirements of IEEE 802.11a RF systems.

Ordering Information

RF5540SB	5-Piece Bag
RF5540SQ	25-Piece Bag
RF5540SR	Standard 100-Piece Bag
RF5540TR7	Standard 2500-Piece Reel
RF5540PCK-410	Fully Assembled Evaluation Board and 5 Loose Sample Pieces

Optimum Technology Matching® Applied

- | | | | |
|--------------------------------------|--------------------------------------|--|------------------------------------|
| <input type="checkbox"/> GaAs HBT | <input type="checkbox"/> SiGe BiCMOS | <input checked="" type="checkbox"/> GaAs pHEMT | <input type="checkbox"/> GaN HEMT |
| <input type="checkbox"/> GaAs MESFET | <input type="checkbox"/> Si BiCMOS | <input type="checkbox"/> Si CMOS | <input type="checkbox"/> BiFET HBT |
| <input type="checkbox"/> InGaP HBT | <input type="checkbox"/> SiGe HBT | <input type="checkbox"/> Si BJT | <input type="checkbox"/> LDMOS |

RF MICRO DEVICES®, RFMD®, Optimum Technology Matching®, Enabling Wireless Connectivity™, PowerStar®, POLARIS™ TOTAL RADIO™ and UltimateBlue™ are trademarks of RFMD, LLC. BLUETOOTH is a trademark owned by Bluetooth SIG, Inc., U.S.A. and licensed for use by RFMD. All other trade names, trademarks and registered trademarks are the property of their respective owners. ©2006, RF Micro Devices, Inc.

Absolute Maximum Ratings

Parameter	Rating	Unit
DC Supply Voltage	5.5	V
Full Spec Compliant Temperature Range	-15 to +75	°C
Storage Temperature	-40 to +150	°C
ESD - Human Body Model	500	V
ESD - CDM	1000	V
LNA Input Power (No Damage)	5	dBm
Moisture Sensitivity	MSL2	



Caution! ESD sensitive device.

Exceeding any one or a combination of the Absolute Maximum Rating conditions may cause permanent damage to the device. Extended application of Absolute Maximum Rating conditions to the device may reduce device reliability. Specified typical performance or functional operation of the device under Absolute Maximum Rating conditions is not implied.

The information in this publication is believed to be accurate and reliable. However, no responsibility is assumed by RF Micro Devices, Inc. ("RFMD") for its use, nor for any infringement of patents, or other rights of third parties, resulting from its use. No license is granted by implication or otherwise under any patent or patent rights of RFMD. RFMD reserves the right to change component circuitry, recommended application circuitry and specifications at any time without prior notice.



RFMD Green: RoHS compliant per EU Directive 2002/95/EC, halogen free per IEC 61249-2-21, < 1000ppm each of antimony trioxide in polymeric materials and red phosphorus as a flame retardant, and <2% antimony in solder.

Parameter	Specification			Unit	Condition
	Min.	Typ.	Max.		
Compliance					IEEE802.11a, FCC CFR 15.247, .205, .209, EN and JDEC, $V_{DD}=2.7$ to $4.2V$, $LNA_EN=2.5$ to $V_{DD}-0.2V$, Temp= $-15^{\circ}C$ to $+75^{\circ}C$, Freq= $4.9GHz$ to $5.85GHz$, unless otherwise noted.
Receive Parameters					
Frequency	4.90		5.85	GHz	
LNA Voltage Supply (V_{DD})	2.7	3.6	4.2	V	
LNA Enable Voltage (LNA-EN)					
LNA Enabled	2.5	3.3	$V_{DD} - 0.2$	V	
LNA Off	0		0.2	V	LNA_EN off turns bypass switch ON
Switch Control Logic					
Low		0	0.2	V	
High	2.5	3.3	$V_{DD} - 0.2$	V	
LNA Current					
LNA V_{DD}		17	22	mA	LNA in "ON" State, over all conditions
LNA V_{EN}	0	5	30	uA	LNA in "OFF" State, over all conditions
LNA_EN Current			1	mA	LNA in "ON" State, over all conditions
LNA_EN Leakage			100	uA	LNA in "OFF" State, over all conditions
Gain					
WiFi RX	11	16	20	dB	WiFi ANT-RX, 4.9GHz to 5.85GHz, over all conditions
Bypass Mode	-12	-9	-7	dB	WiFi ANT-RX, Bypass Mode, over all conditions
Noise Figure		2.4	3.2	dB	$V_{DD} \geq 3.0V$, including switch, over all conditions
Passband Ripple					
WiFi RX Mode	-1.3		+1.3	dB	Over all conditions, 5.10GHz to 5.85GHz
WiFi RX Bypass Mode	-0.8		+0.8	dB	Over all conditions, 4.9GHz to 5.1GHz
WiFi RX Port Return Loss	-0.8		+0.8	dB	Over all conditions
WiFi RX Port Return Loss		10		dB	Over all conditions
IP1dB		-7		dBm	Over all conditions
IIP3		3		dBm	Over all conditions

Parameter	Specification			Unit	Condition
	Min.	Typ.	Max.		
Transmit Switch Parameters					
Frequency	4.90		5.85	GHz	
Insertion Loss		1	1.8	dB	TX-ANT, over all conditions
Noise Figure		1	1.8	dB	TX-ANT, over all conditions
Passband Ripple	-0.2		+0.2	dB	Over all conditions
P1dB to TX Path	25	30		dBm	Switch ports only, over all conditions
Input Power	18			dBm	System EVM=0.5% assumed for the incoming signal; 18dbm at the input with 1% composite EVM at the output.
Input Return Loss	9.6	12		dB	Over all conditions
Output Return Loss	8.5	12		dB	Over all conditions
Port Impedance Tuning		50		Ω	All RF ports tuned for 50 Ω system
Isolation TX to RX	20			dB	TX DC mode, path ANT to RX, over all conditions
Isolation RX to TX	20			dB	WiFi RX Bypass Mode, path ANT-TX, over all conditions
Switch Control Current		35	50	μ A	Per control line, over all conditions
Switch Control Speed		75	150	nsec	Over all conditions

Pin	Function	Description
1	GND	Ground.
2	ANT	This is the common port (antenna). Matched to 50Ω. External DC blocking capacitor required.
3	GND	Ground.
4	LNA_EN	LNA Enable/Bypass Enable control pin. See switch truth table for proper settings.
5	GND	Ground.
6	VDD	Supply voltage to the LNA.
7	NC	No Board Connection Allowed.
8	RX_OUT	Receive port for 802.11a/n band. RX output includes integrated DC-block and 50Ω match.
9	NC	No Board Connection Allowed.
10	GND	Ground.
11	TX_IN	Transmit port for 802.11a/n band. Matched to 50Ω. External DC blocking capacitor required.
12	C_TX/RX	Transmit and receive mode control pin. See switch truth table for proper settings.

Pin Out

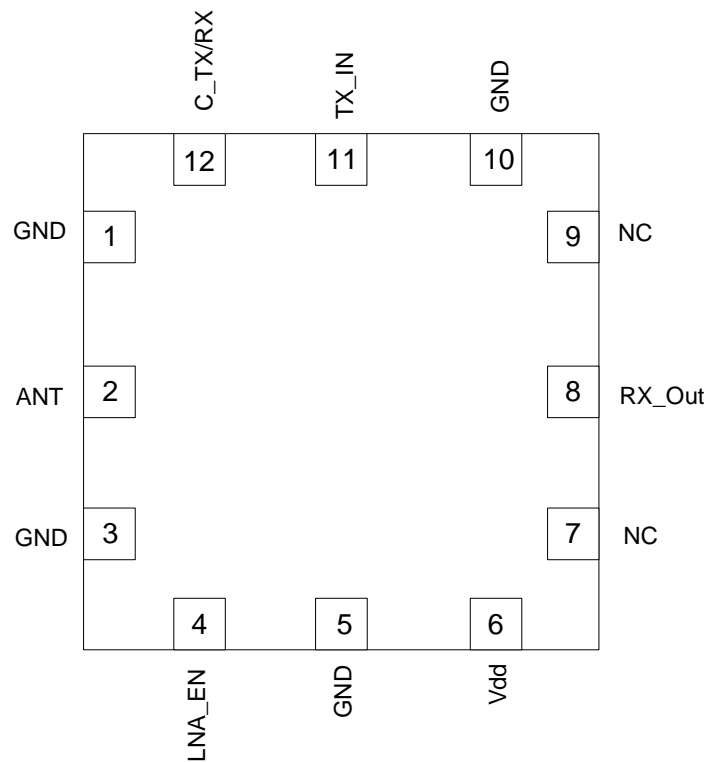

Switch Logic Truth Table:

Mode	C_TX/RX	LNA_EN
RX Gain	L	H
RX Bypass	L	L
TX	H	L

Package Drawing

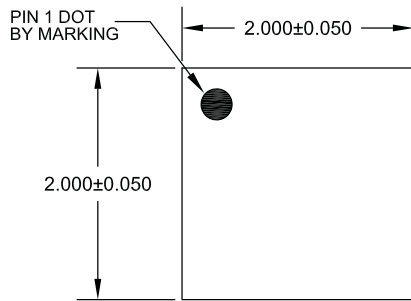

TOP VIEW

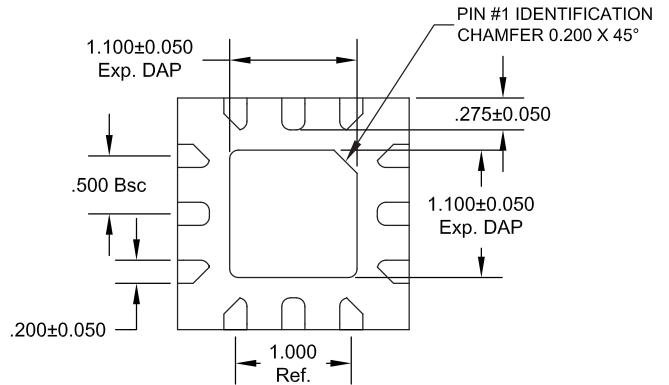

BOTTOM VIEW

A		ETSLP
	MAX.	0.500
	NOM.	0.450
	MIN.	0.400

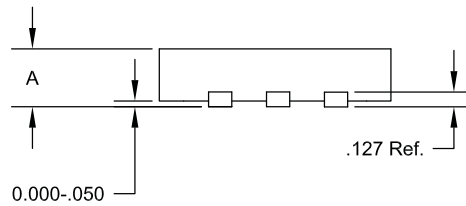

SIDE VIEW

Notes:

1) Pin 1 Shaded Area

PCB Pattern

A = 0.250 x 0.402 (mm) Typ
 B = 0.402 x 0.250 (mm) Typ
 C = 0.250 x 0.402 (mm) 60% Rounded Rectangle
 D = 0.402 x 0.250 (mm) 60% Rounded Rectangle
 E = 1.050 x 1.050 (mm)

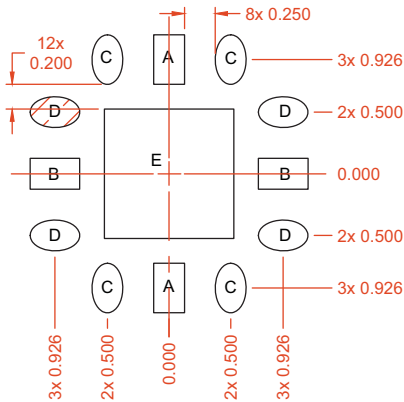

A = 0.350 x 0.502 (mm) Typ
 B = 0.502 x 0.350 (mm) Typ
 C = 0.350 x 0.502 (mm) 60% Rounded Rectangle
 D = 0.502 x 0.350 (mm) 60% Rounded Rectangle
 E = 1.150 x 1.150 (mm)

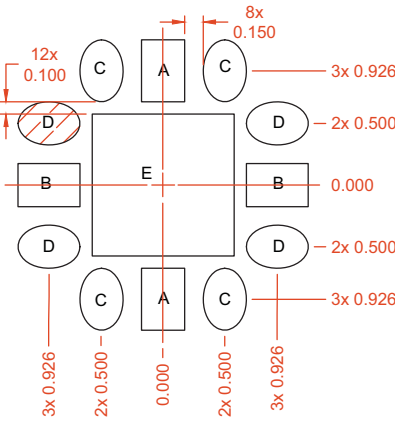

A = 0.225 x 0.362 (mm)
 B = 0.362 x 0.225 (mm)
 C = 0.225 x 0.362 (mm) 60% Rounded Rectangle
 D = 0.362 x 0.225 (mm) 60% Rounded Rectangle
 E = 0.945 x 0.945 (mm)

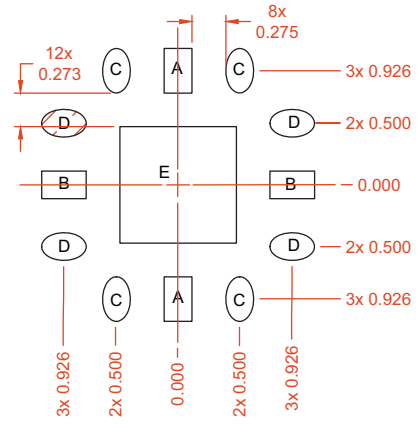

Shaded area represents Pin 1 location.

Application Schematic

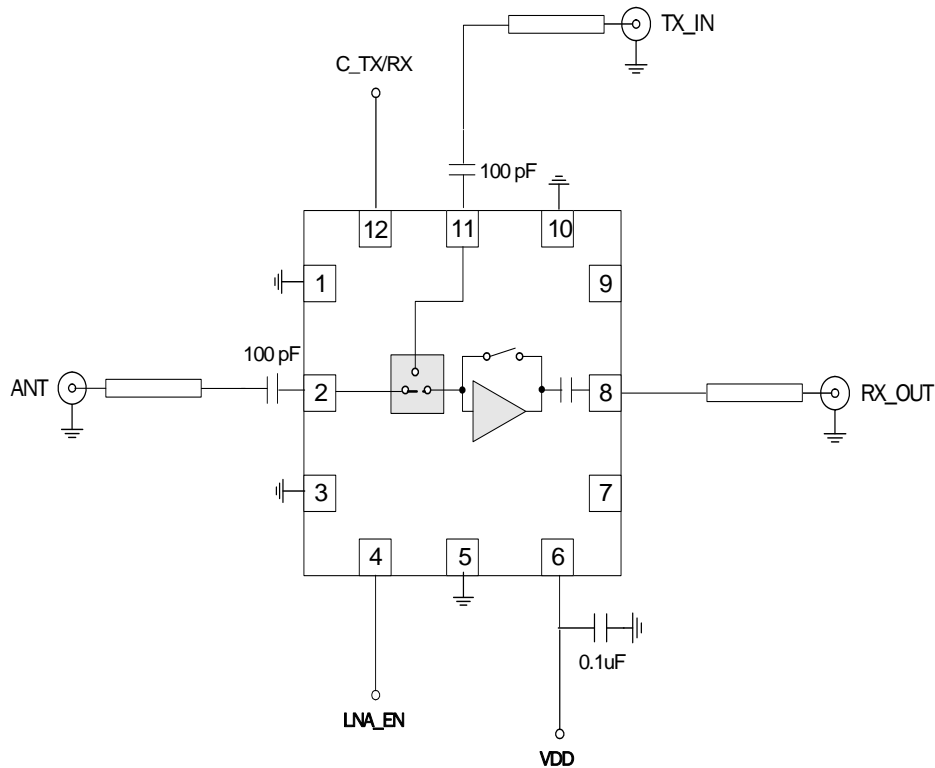

RF5540 Performance Plots

