



Features

- Excellent Linearity
- Extremely High Output Capability
- Voltage Controlled Attenuator
- Power Enable Feature
- Optimal Reliability
- Low Noise
- Unconditionally Stable Under all Terminations
- 27dB Typical Gain at 1003MHz
- 410mA Typical at 12VDC

Applications

- 45MHz to 1003MHz Downstream Edge QAM RF Modulators
- Headend Equipment

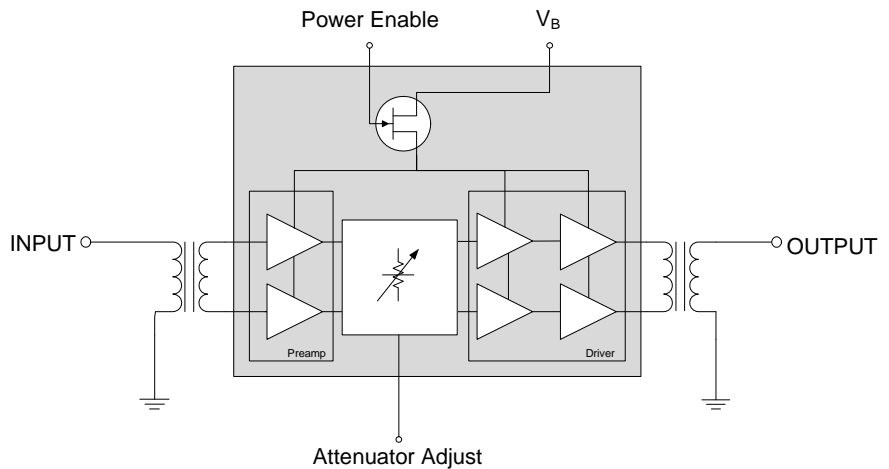

Functional Block Diagram

Product Description

The RFAM2790 is an Integrated Edge QAM Amplifier Module. The part employs GaAs pHEMT die, GaAs MESFET die, a 20dB range variable attenuator and a power enable feature, has high output capability, and is operated from 45MHz to 1003MHz. It provides excellent linearity and superior return loss performance with low noise and optimal reliability.

Ordering Information

RFAM2790TR7	7" Reel
RFAM2790TR13	13" Reel
RFAM2790SB	Sample Pack
RFAM2790SR	Sample Reel
RFAM2790PCK-410	Fully Assembled Evaluation Board

Optimum Technology Matching® Applied

- | | | | |
|---|--------------------------------------|--|------------------------------------|
| <input type="checkbox"/> GaAs HBT | <input type="checkbox"/> SiGe BiCMOS | <input checked="" type="checkbox"/> GaAs pHEMT | <input type="checkbox"/> GaN HEMT |
| <input checked="" type="checkbox"/> GaAs MESFET | <input type="checkbox"/> Si BiCMOS | <input type="checkbox"/> Si CMOS | <input type="checkbox"/> BiFET HBT |
| <input type="checkbox"/> InGaP HBT | <input type="checkbox"/> SiGe HBT | <input type="checkbox"/> Si BJT | <input type="checkbox"/> LDMOS |

RF MICRO DEVICES®, RFMD®, Optimum Technology Matching®, Enabling Wireless Connectivity™, PowerStar®, POLARIS™ TOTAL RADIO™ and UltimateBlue™ are trademarks of RFMD, LLC. BLUETOOTH is a trademark owned by Bluetooth SIG, Inc., U.S.A. and licensed for use by RFMD. All other trade names, trademarks and registered trademarks are the property of their respective owners. ©2006, RF Micro Devices, Inc.

Absolute Maximum Ratings

Parameter	Rating	Unit
RF Input Voltage (single tone)	TBD	dBmV
V+ DC Supply Over-Voltage (5 minutes)	14	V
Storage Temperature	-40 to +100	°C
Operating Mounting Base Temperature	-40 to +85	°C



Caution! ESD sensitive device.

Exceeding any one or a combination of the Absolute Maximum Rating conditions may cause permanent damage to the device. Extended application of Absolute Maximum Rating conditions to the device may reduce device reliability. Specified typical performance or functional operation of the device under Absolute Maximum Rating conditions is not implied.

The information in this publication is believed to be accurate and reliable. However, no responsibility is assumed by RF Micro Devices, Inc. ("RFMD") for its use, nor for any infringement of patents, or other rights of third parties, resulting from its use. No license is granted by implication or otherwise under any patent or patent rights of RFMD. RFMD reserves the right to change component circuitry, recommended application circuitry and specifications at any time without prior notice.



RoHS (Restriction of Hazardous Substances): Compliant per EU Directive 2002/95/EC.

Parameter	Specification			Unit	Condition
	Min.	Typ.	Max.		
Overall					V+ = 12V; T _{MB} = 30 °C; Z _S = Z _L = 75Ω; Attenuation = 0dB
Power Gain		27.0		dB	f = 45MHz
	26.0	27.0	28.0	dB	f = 1003MHz
Slope[1]	-0.5	0.0	1.0	dB	f = 45MHz to 1003MHz
Flatness of Frequency Response		0.5	1	dB	f = 45MHz to 1003MHz (Peak to Valley)
Input Return Loss	18	20		dB	f = 45MHz to 1003MHz
Output Return Loss	16	18		dB	
Noise Figure		4.0	5.0	dB	f = 50MHz to 1003MHz
Total Current Consumption (DC)		410.0	420	mA	
Distortion					V+ = 12V; T _{MB} = 30 °C; Z _S = Z _L = 75Ω; Attenuation = 0dB
Adjacent Channel Power Ratio (ACPR); N = 4 contiguous 256QAM channels			-58	dBc	Channel Power = 58dBmV; Adjacent channel up to 750kHz from channel block edge
			-60	dBc	Channel Power = 58dBmV; Adjacent channel (750kHz from channel block edge to 6MHz from channel block edge)
			-63	dBc	Channel Power = 58dBmV; Next-adjacent channel (6MHz from channel block edge to 12MHz from channel block edge)
			-65	dBc	Channel Power = 58dBmV; Third-adjacent channel (12MHz from channel block edge to 18MHz from channel block edge)
2nd Order Harmonic (HD2); N = 1 256QAM channel			-63	dBc	Channel Power = 66dBmV; In each of 2N contiguous 6MHz channels coinciding with 2nd harmonic components (up to 1000MHz);
3rd Order Harmonic (HD3); N = 1 256QAM channel			-63	dBc	Channel Power = 66dBmV; In each of 3N contiguous 6MHz channels coinciding with 3rd harmonic components (up to 1000MHz);
CTB		-67		dBc	V _O = 46dBmV, flat, 79 analog channels plus 75 digital channels (-6dB offset)[2]
XMOD		-60		dBc	
CSO		-70		dBc	
CIN		64		dB	

Parameter	Specification			Unit	Condition
	Min.	Typ.	Max.		
Attenuator					$V_+ = 12V$; $T_{MB} = 30^\circ C$; $Z_S = Z_L = 75\Omega$
Attenuator Range	0 to 20			dB	Attenuator Voltage 0V to 12V
Power Enable/Disable					
		Amp enabled			Logic high (3.3V) applied to power enable pin
		Amp disabled			Logic low (0V) applied to power enable pin

[1] The slope is defined as the difference between the gain at the start frequency and the gain at the stop frequency.

[2] 79 analog channels, NTSC frequency raster: 55.25MHz to 547.25MHz, +46dBmV flat output level, plus 75 digital channels, -6dB offset relative to the equivalent analog carrier.

Composite Second Order (CSO) - The CSO parameter (both sum and difference products) is defined by the NCTA.

Composite Triple Beat (CTB) - The CTB parameter is defined by the NCTA.

Cross Modulation (XMOD) - Cross modulation (XMOD) is measured at baseband (selective voltmeter method), referenced to 100% modulation of the carrier being tested.

Carrier to Intermodulation Noise (CIN) - The CIN parameter is defined by ANSI/SCTE 17 (Test procedure for carrier to noise).

Application Circuit

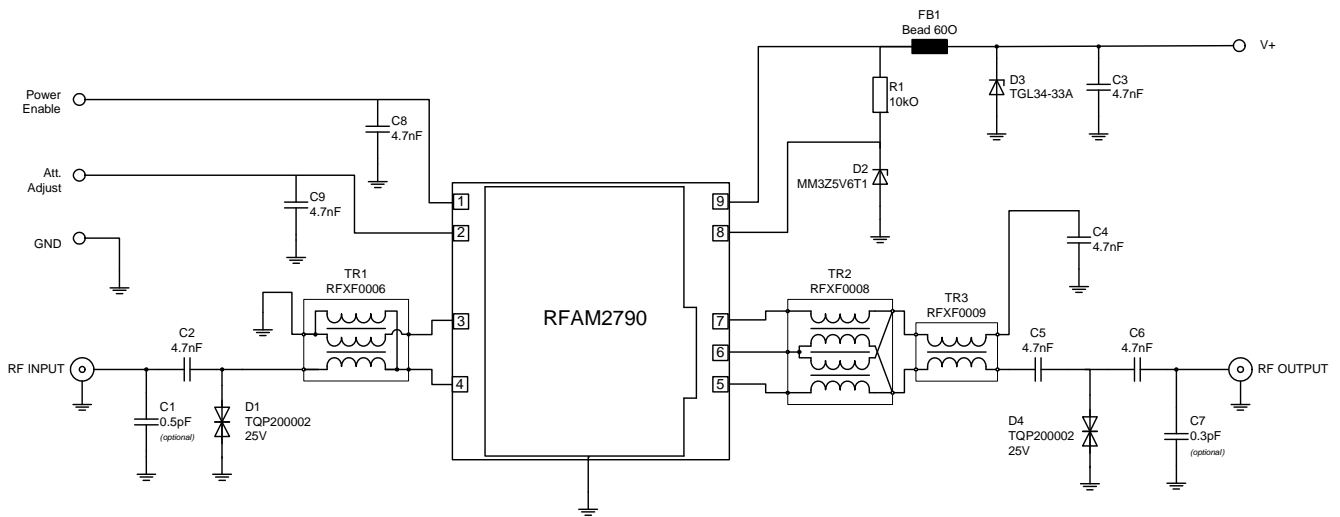

Evaluation Board Layout

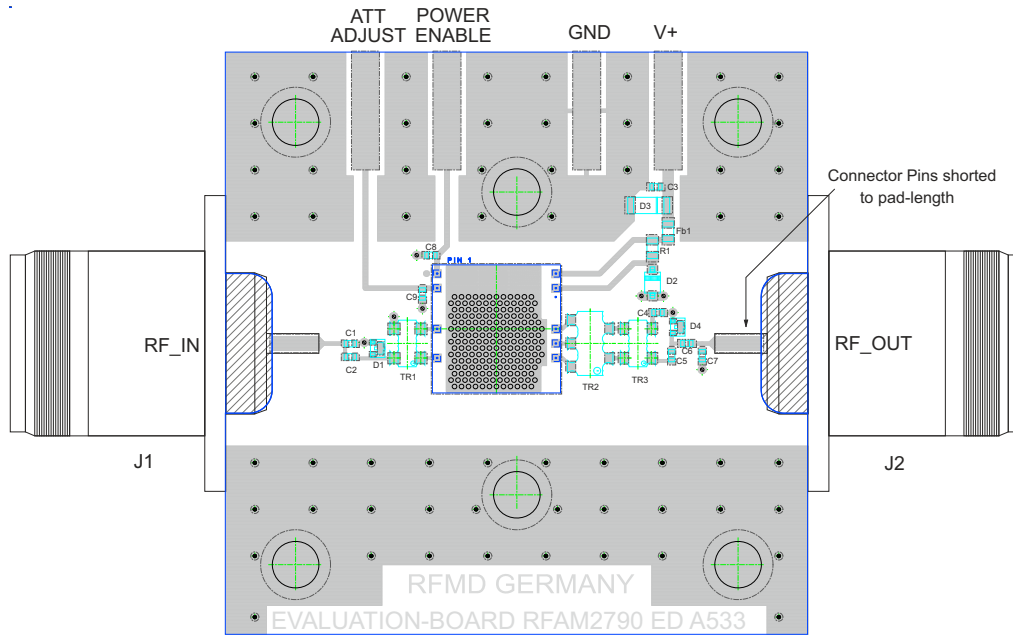

Component Chart

Component Type	Value	Qty	Designator
Capacitor	0.5pF (optional)	1	C1
Capacitor	4.7nF	7	C2, C3, C4, C5, C6, C8, C9
Capacitor	0.3pF (optional)	1	C7
Resistor	10kΩ	1	R1
Chip Bead	60Ω at 100MHz	1	FB1
ESD Protection Diode	TQP200002	2	D1, D4
Zener Voltage Diode	MM3Z5V6T1G	1	D2
Transient Voltage Suppressor Diode	TGL34-33A	1	D3
Transformer	RFXF0006	1	TR1
Transformer	RFXF0008	1	TR2
Transformer	RFXF0009	1	TR3

Pin Names and Descriptions

Pin	Name	Description
1	Power Enable	Logic Level (3.3V) Power Enable Control
2	Attenuator Adjust	Voltage Adjustable Attenuator
3	RF IN (+)	RF AMP Positive Input
4	RF IN (-)	RF AMP Negative Input
5	RF OUT (-)	RF AMP Negative Output
6	12V Out	12V Output
7	RF OUT (+)	RF AMP Positive Output
8	5.6V V+	Supply Voltage 5.6V
9	12V V+	Supply Voltage 12V

Pin Configuration

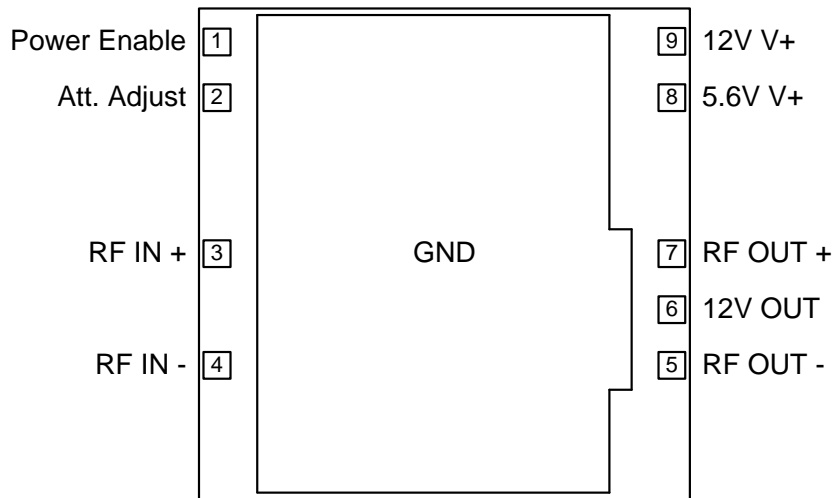

Package Drawing

Dimensions in millimeters

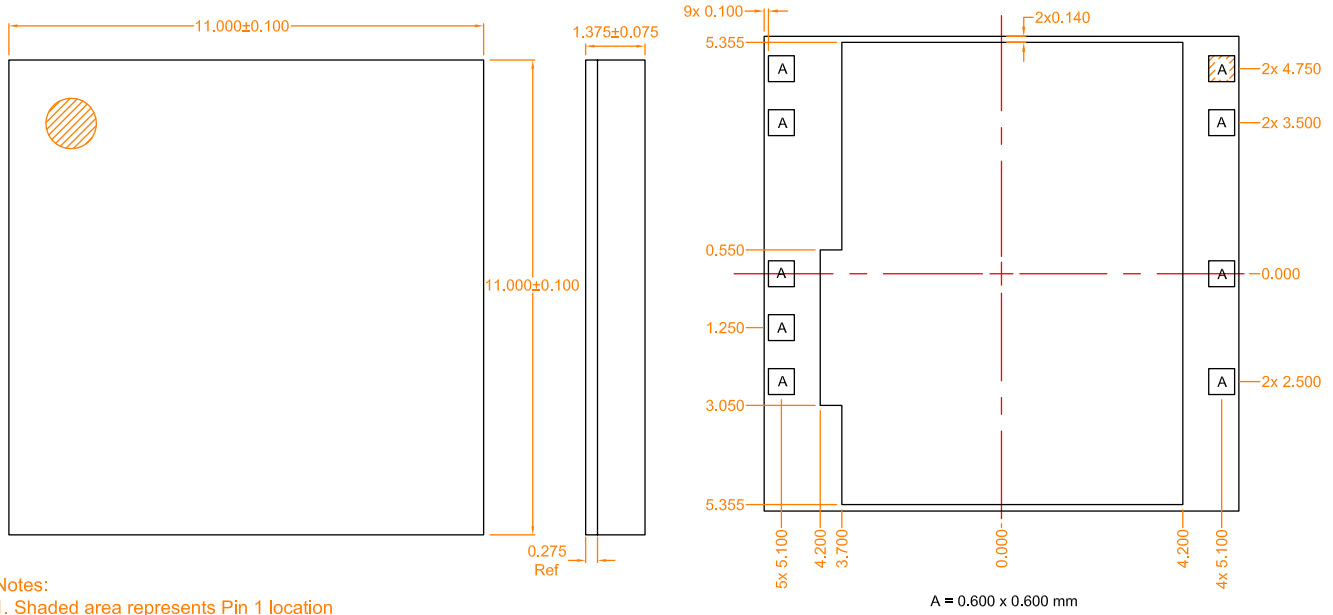

PCB Metal Land Pattern

Dimensions in millimeters

