



Product Description

RFMD's CGA-1518Z is a high performance InGaP HBT MMIC Amplifier. Designed with InGaP process technology for excellent reliability. A Darlington configuration is utilized for broadband performance. The heterojunction increases breakdown voltage and minimizes leakage current between junctions. The CGA-1518Z contains two amplifiers for use in wideband push-pull CATV amplifiers requiring excellent second order performance. The second and third order non-linearities are greatly improved in the push-pull configuration.

Optimum Technology Matching® Applied

- GaAs HBT
- GaAs MESFET
- InGaP HBT
- SiGe BiCMOS
- Si BiCMOS
- SiGe HBT
- GaAs pHEMT
- Si CMOS
- Si BJT
- GaN HEMT
- InP HBT
- RF MEMS
- LDMOS

Amplifier Configuration

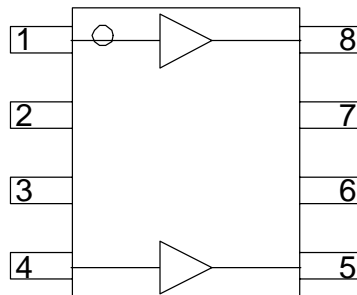

Features

- 5V Single Supply
- Excellent Linearity Performance at +34dBmV Output Power Per Tone
- Two Amplifiers in Each SOIC-8 Package Simplify Push-Pull Configuration PC Board Layout
- Available in Lead-Free, RoHS Compliant, and Green Packaging
- SOIC-8 Package

Applications

- CATV Head End Driver and Predriver Amplifier
- CATV Line Driver Amplifier

| Parameter | Specification | | | Unit | Condition |
|---|---------------|------|------|------|--|
| | Min. | Typ. | Max. | | |
| Small Signal Gain | 14.9 | 15.5 | | dB | 50MHz to 1000MHz |
| Gain Flatness | | ±0.6 | | dB | 50Hz to 1000MHz |
| Output IP3 | | 37 | | dBm | 500MHz Tone Spacing=1MHz P _{OUT} per Tone=+6dBm |
| Output Power at 1dB Gain Compression | | 20 | | dBm | 500MHz |
| Input Return Loss | | 20 | | dB | 500MHz |
| Output Return Loss | | 20 | | dB | 500MHz |
| Noise Figure Balun Insertion Loss Included | | 4.5 | | dB | 50MHz to 1000MHz |
| CSO | | 77 | | dBc | 79 Ch., Flat Tilt, +34dBmV |
| CTB | | 70 | | dBc | 79 Ch., Flat Tilt, +34dBmV |
| XMOD | | 61 | | dBc | 79 Ch., Flat Tilt, +34dBmV |
| Device Operating Voltage | | 5.0 | | V | |
| Device Operating Current | | 150 | | mA | 5V V _{CC} |
| Thermal Resistance (Junction to Lead) | | 30 | | °C/W | Junction to case slug |

Test Conditions: V_{CC}=5V, I_D=150mA Typ., T_L=25°C, Z_S=Z_L=75Ω, Push Pull Application Circuit

Absolute Maximum Ratings

| Parameter | Rating | Unit |
|--------------------------------|------------|------|
| Max Device Current (I_D) | 300 | mA |
| Max Device Voltage (V_D) | 6.0 | V |
| Max RF Input Power | 18 | dBm |
| Max Junction Temp (T_J) | 150 | °C |
| Operating Temp Range (T_L) | -40 to +85 | °C |
| Max Storage Temp | 150 | °C |
| Min Storage Temp | -40 | °C |

Operation of this device beyond any one of these limits may cause permanent damage. For reliable continuous operation, the device voltage and current must not exceed the maximum operating values specified in the table on page one.

Bias Conditions should also satisfy the following expression:

$$I_D V_D < (T_J - T_L) / R_{TH, j-l} \text{ and } T_L = T_{LEAD}$$



Caution! ESD sensitive device.

Exceeding any one or a combination of the Absolute Maximum Rating conditions may cause permanent damage to the device. Extended application of Absolute Maximum Rating conditions to the device may reduce device reliability. Specified typical performance or functional operation of the device under Absolute Maximum Rating conditions is not implied.

RoHS status based on EU Directive 2002/95/EC (at time of this document revision).

The information in this publication is believed to be accurate and reliable. However, no responsibility is assumed by RF Micro Devices, Inc. ("RFMD") for its use, nor for any infringement of patents, or other rights of third parties, resulting from its use. No license is granted by implication or otherwise under any patent or patent rights of RFMD. RFMD reserves the right to change component circuitry, recommended application circuitry and specifications at any time without prior notice.

Input Return Loss

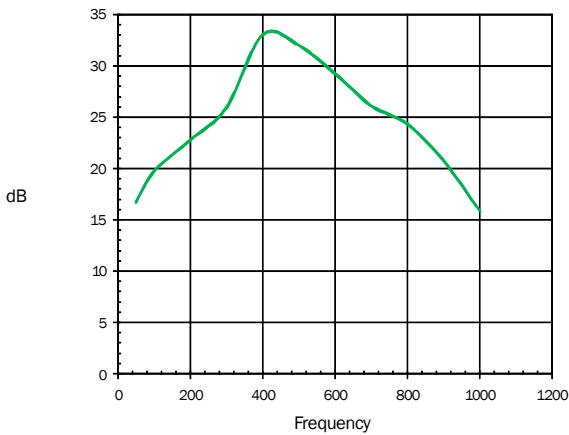

Output Return Loss

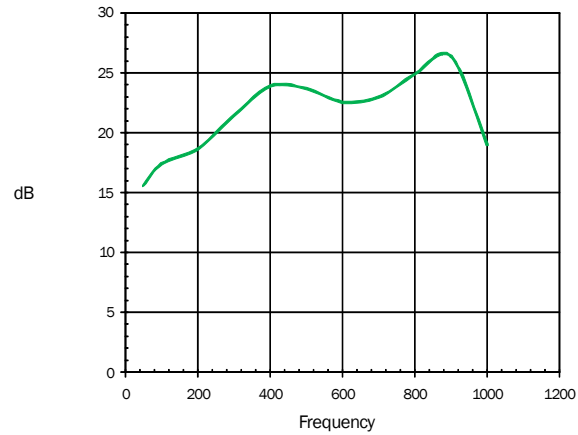

Gain

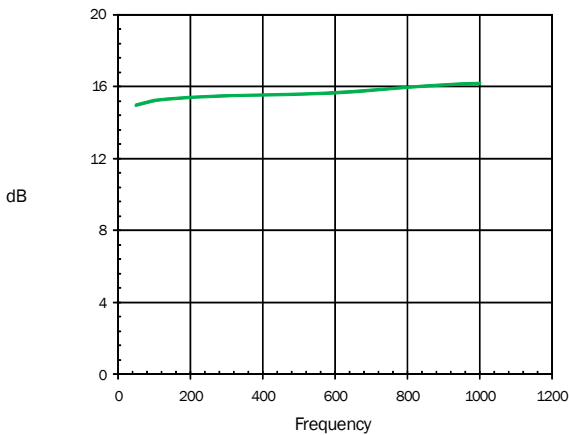

Reverse Isolation

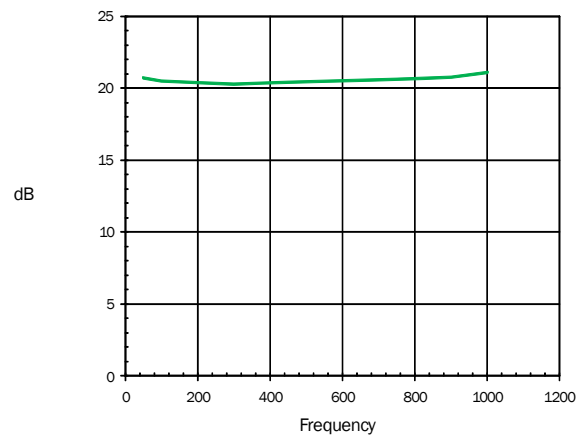

Noise Figure

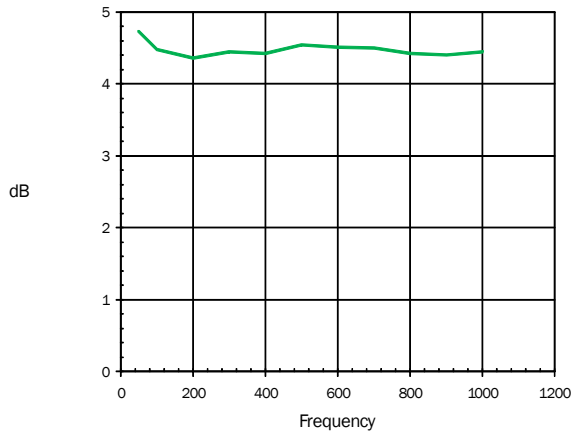

Output P1dB

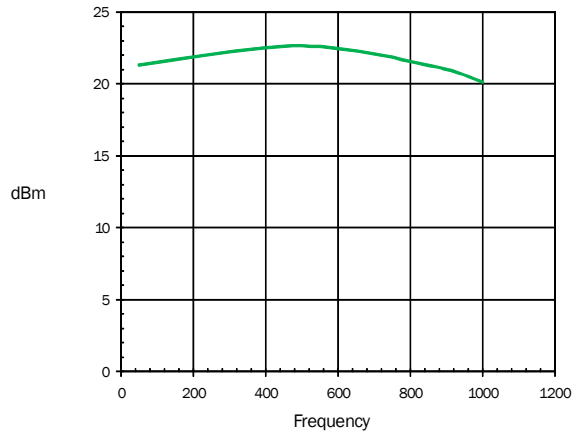

Output IP3

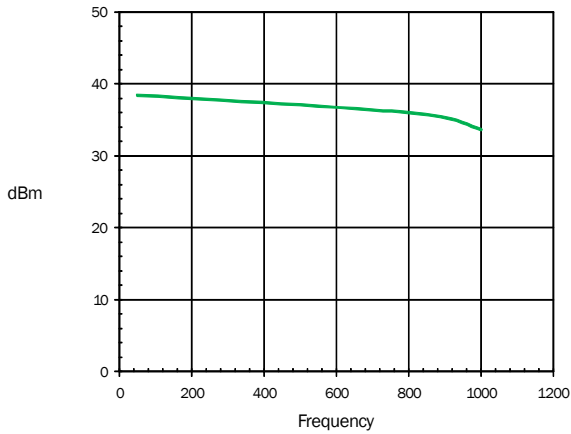

XMOD

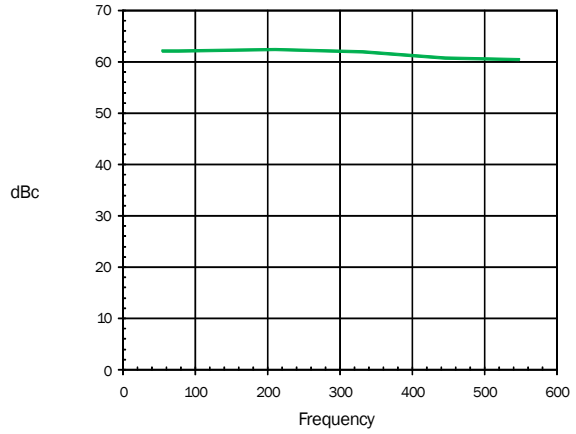

CSO

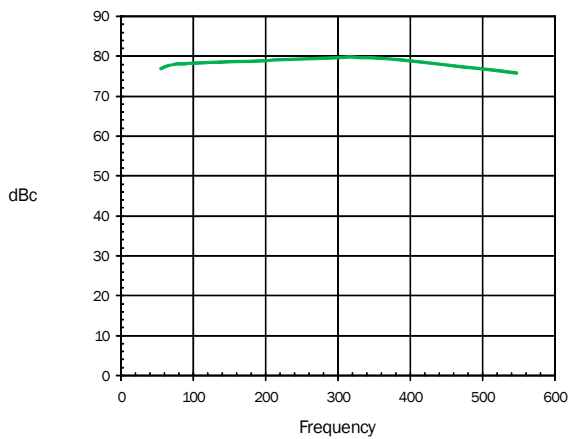

CTB

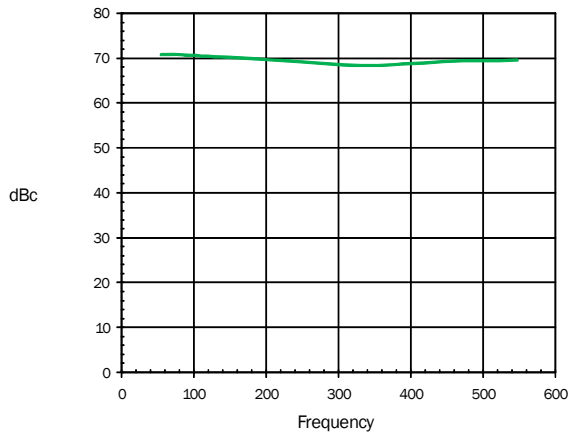

50 MHz to 1000 MHz Evaluation Board Schematic

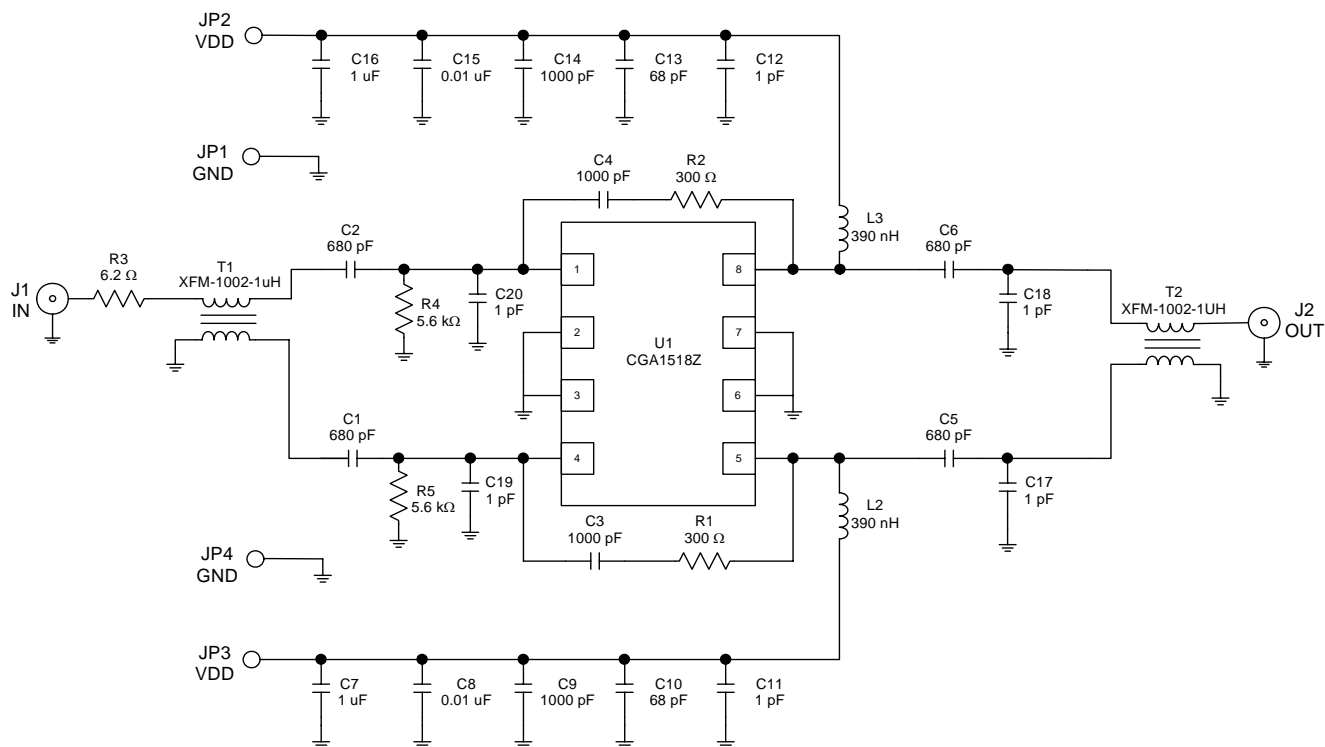

Component Chart

| Value | Qty | Location |
|---------------------|-----|------------------------------|
| RFMD™ CGA-1518Z | 1 | U1 |
| 1 pF | 6 | C11, C12, C17, C18, C19, C20 |
| 68 pF | 2 | C10, 13 |
| 680 pF | 4 | C1, C2, C5, C6 |
| 1000 pF | 4 | C3, C4, C9, C14 |
| 0.01 uF | 2 | C8, 15 |
| 1 uF | 2 | C7, C16 |
| 6.2Ω | 1 | R3 |
| 5.6kΩ | 2 | R4, R5 |
| 300Ω | 2 | R1, R2 |
| 390nH | 2 | L2, L3 |
| RFMD™ XFM-1002-1 uH | 2 | T1, T2 |

50MHz to 1000MHz Evaluation Layout

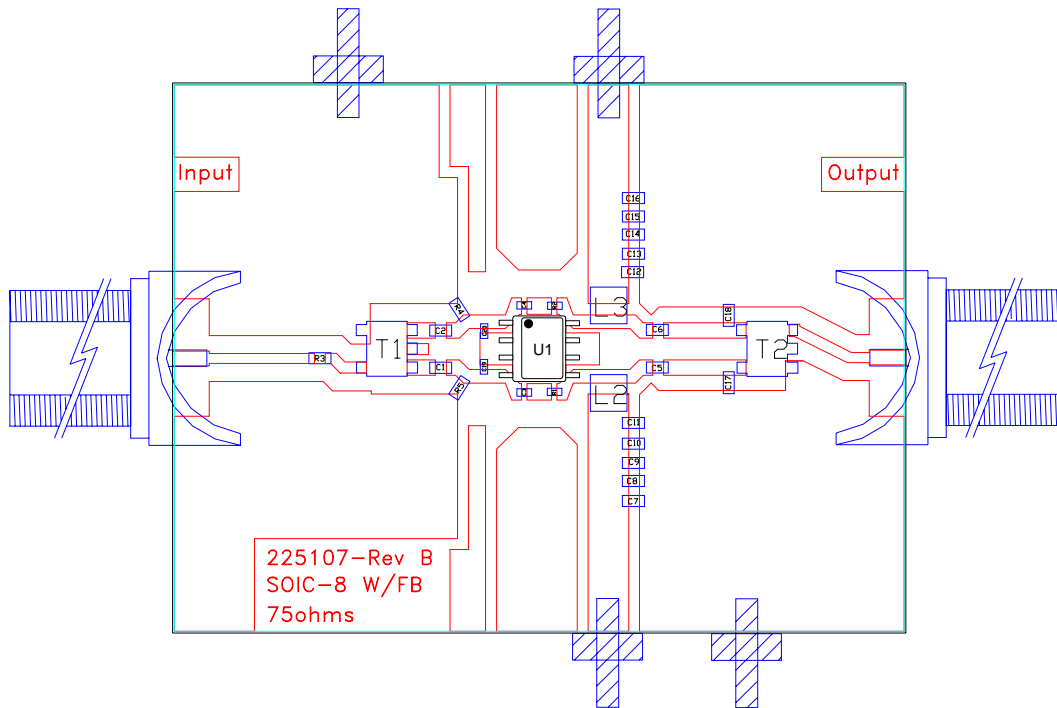

| Pin | Function | Description |
|------------|------------|--|
| 1 | RF IN | RF input pin. External DC-blocking capacitor is required. |
| 2, 3, 6, 7 | GND | Connection to ground. Use via holes for best performance to reduce lead inductance as close to ground leads as possible. |
| 4 | RF IN | Same as pin 1. |
| 5 | RF OUT/VCC | RF output and bias pin (open collector). |
| 8 | RF OUT/VCC | Same as pin 5. |
| EPAD | GND | Exposed area on the bottom side of the package must be soldered to the ground plane of the board for optimum thermal and RF performance. Several vias should be located under the EPAD as shown in the recommended land pattern. |

Pin Out

Amplifier Configuration

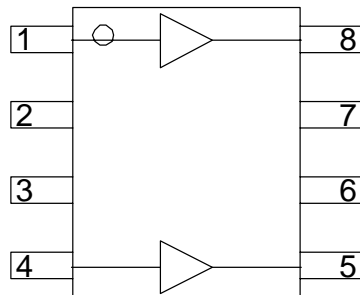

Part Identification

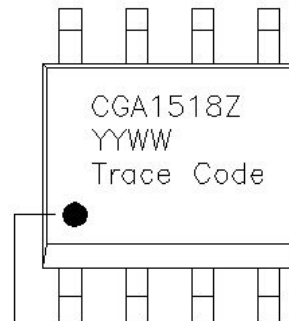

Pin 1 Indicator

Suggested Pad Layout

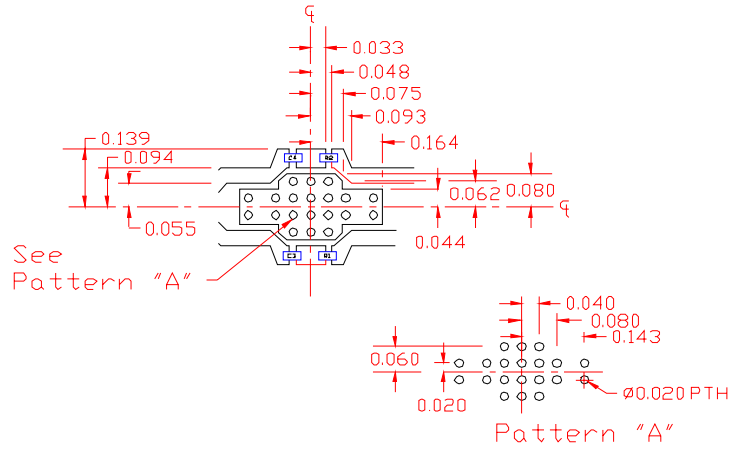

Package Drawing and Marking

Dimensions in inches (millimeters)

Refer to drawing posted at www.rfmd.com for tolerances.

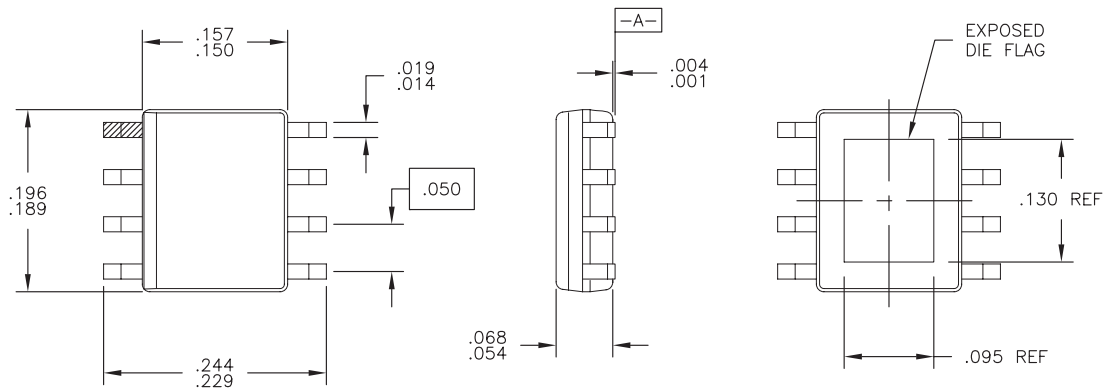

NOTES:

1. SHADED LEAD IS PIN 1.
2. LEAD COPLANARITY: .003 WITH RESPECT TO DATUM 'A'.
3. DIMENSIONS DO NOT INCLUDE MOLD FLASH OR PROTRUSIONS.

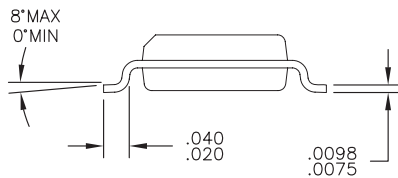

Ordering Information

| Part Number | Description | Reel Size | Devices/Reel |
|-----------------|-------------------------------------|-----------|--------------|
| CGA1518ZSB | 5pcs Sample Bag | NA | NA |
| CGA1518ZSQ | 25pcs Sample Bag | NA | NA |
| CGA1518ZSR | Lead Free, RoHS Compliant | 7 | 100 |
| CGA1518ZTR7 | Lead Free, RoHS Compliant | 7 | 750 |
| CGA1518ZTR13 | Lead Free, RoHS Compliant | 13 | 2500 |
| CGA1518PCBA-410 | 50 MHz to 1000 MHz Evaluation Board | NA | NA |