



### Product Description

RFMD's SBB3000 is a high performance InGaP HBT MMIC amplifier utilizing a Darlington configuration with an active bias network. The active bias network provides stable current over temperature and process Beta variations. The SBB3000 product is designed for high linearity 5V gain block applications that require excellent gain flatness, small size, and minimal external components. It is internally matched to 50Ω.

### Features

- Single Fixed 5V Supply
- Patented Self Bias Circuit and Thermal Design
- Gain = 16.4dB at 1950MHz
- P1dB = 15.2dBm at 1950MHz
- OIP3 = 29.5dBm at 1950MHz
- Robust 1000V ESD, Class 1C HBM

### Applications

- PA Driver Amplifier
- RF Pre-Driver and RF Receiver Path
- Military Communications
- Test and Instrumentation

**Optimum Technology Matching® Applied**

- GaAs HBT
- GaAs MESFET
- InGaP HBT
- SiGe BiCMOS
- Si BiCMOS
- SiGe HBT
- GaAs pHEMT
- Si CMOS
- Si BJT
- GaN HEMT
- InP HBT
- RF MEMS
- LDMOS

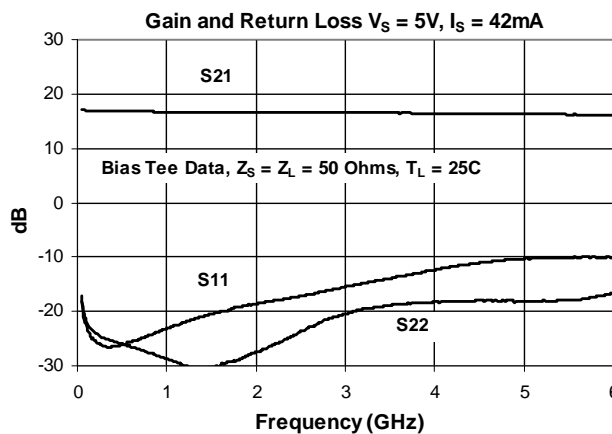

Parameter	Specification			Unit	Condition
	Min.	Typ.	Max.		
Small Signal Gain		16.6		dB	850MHz
		16.4		dB	1950MHz
		16.3		dB	2400MHz
Output Power at 1dB Compression		15.6		dBm	850MHz
		15.2		dBm	1950MHz
		15.4		dBm	2400MHz
Output Third Order Intercept Point		30.0		dBm	850MHz
		29.5		dBm	1950MHz
		29.5		dBm	2400MHz
Input Return Loss		21		dB	1950MHz
Output Return Loss		25.5		dB	1950MHz
Noise Figure		3.9		dB	1950MHz
Device Operating Voltage		4.2		V	$R_{DC} = 20\Omega, V_S = 5.0V$
Device Operating Current	38	42	46	mA	$R_{DC} = 20\Omega, V_S = 5.0V$
Operational Current Range	30		46	mA	Per user preference via $R_{DC}$
Thermal Resistance		80		°C/W	Junction to lead (89 package)

Test Conditions:  $V_D = 4.2V, I_D = 42mA, T_L = 25^\circ C, OIP_3$  Tone Spacing = 1MHz,  $R_{DC} = 20\Omega$ , Bias Tee Data,  $Z_S = Z_L = 50\Omega, P_{OUT}$  per tone = -5dBm

## Absolute Maximum Ratings

Parameter	Rating	Unit
Max Device Current ( $I_D$ )	100	mA
Max Device Voltage ( $V_D$ )	6	V
Max RF Input Power* (See Note)	+20	dBm
Max Junction Temperature ( $T_J$ )	+150	°C
Operating Temperature Range ( $T_L$ )	-40 to +85	°C
Max Storage Temperature	+150	°C
ESD Rating - Human Body Model (HBM)	Class 1C	

\*Note: Load condition  $Z_L = 50\Omega$

Operation of this device beyond any one of these limits may cause permanent damage. For reliable continuous operation, the device voltage and current must not exceed the maximum operating values specified in the table on page one.

Bias Conditions should also satisfy the following expression:

$$I_D V_D < (T_J - T_L) / R_{TH}, j - l \text{ and } T_L = T_{LEAD}$$



**Caution!** ESD sensitive device.

Exceeding any one or a combination of the Absolute Maximum Rating conditions may cause permanent damage to the device. Extended application of Absolute Maximum Rating conditions to the device may reduce device reliability. Specified typical performance or functional operation of the device under Absolute Maximum Rating conditions is not implied.

The information in this publication is believed to be accurate and reliable. However, no responsibility is assumed by RF Micro Devices, Inc. ("RFMD") for its use, nor for any infringement of patents, or other rights of third parties, resulting from its use. No license is granted by implication or otherwise under any patent or patent rights of RFMD. RFMD reserves the right to change component circuitry, recommended application circuitry and specifications at any time without prior notice.



RFMD Green: RoHS compliant per EU Directive 2002/95/EC, halogen free per IEC 61249-2-21, < 1000ppm each of antimony trioxide in polymeric materials and red phosphorus as a flame retardant, and <2% antimony in solder.

## SBB3089Z Typical RF Performance at Key Operating Frequencies (Bias Tee Data)

Parameter	Unit	100 MHz	500 MHz	850 MHz	1950 MHz	2140 MHz	2400 MHz	3500 MHz
Small Signal Gain	dB	16.9	16.6	16.6	16.4	16.4	16.3	16.1
Output Third Order Intercept Point	dBm	29.5	30.5	30.0	29.5	29.0	29.5	27.0
Output Power at 1dB Compression	dBm	15.6	16.0	15.6	15.2	15.0	15.4	15.2
Input Return Loss	dB	24.0	26.5	24.5	21.0	20.5	20.0	15.5
Output Return Loss	dB	21.5	26.0	26.0	25.5	25.5	27.5	21.0
Reverse Isolation	dB	19.5	19.0	19.5	19.5	19.5	19.5	19.5
Noise Figure	dB	3.7	3.9	3.9	3.9	3.9	4.0	3.8

Test Conditions:  $V_D = 4.2V$ ,  $I_D = 42mA$ , OIP3 Tone Spacing = 1MHz,  $P_{OUT}$  per tone = -5dBm,  $R_{DC} = 20\Omega$ ,  $T_L = 25^\circ C$ ,  $Z_S = Z_L = 50\Omega$

## SBB3089Z Typical Performance with Bias Tees, $V_D = 5V$ with $R_{DC} = 20\Omega$ , $I_D = 42mA$

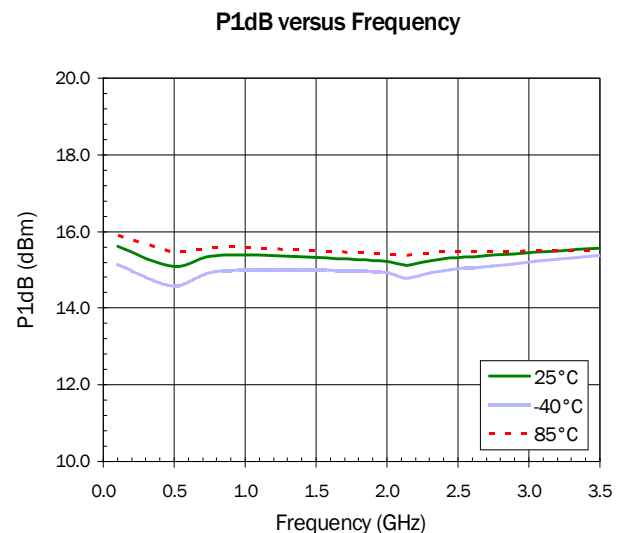
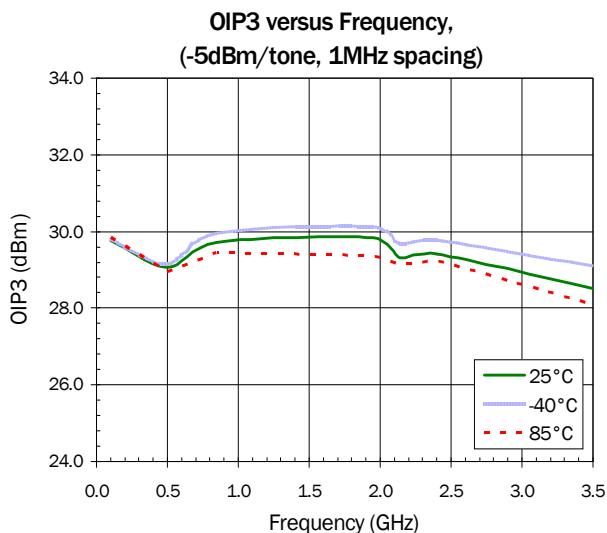

SBB3089Z Typical Performance with Bias Tees,  $V_S = 5V$ ,  $R_{DC} = 20\Omega$ ,  $I_D = 42mA$

**S11 versus Frequency**

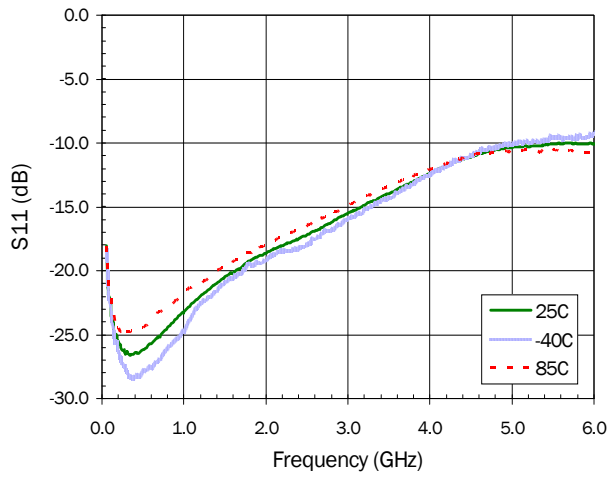

**S21 versus Frequency**

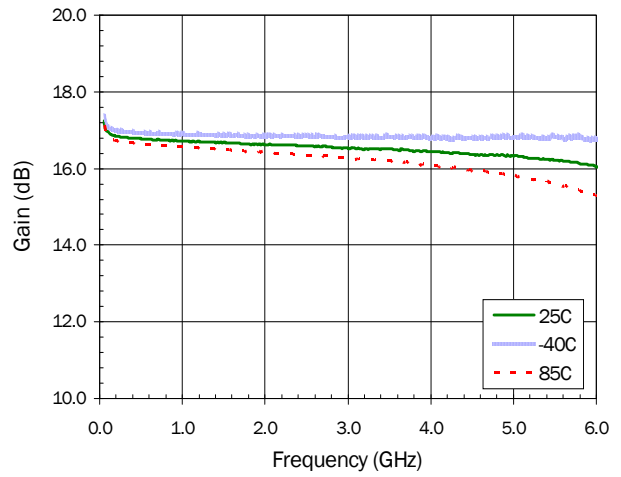

**S12 versus Frequency**

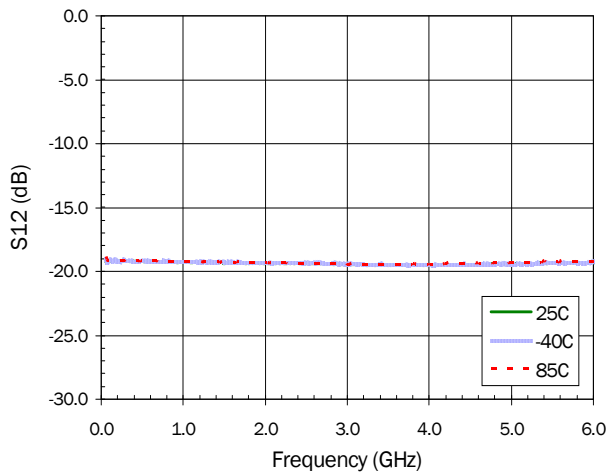

**S22 versus Frequency**

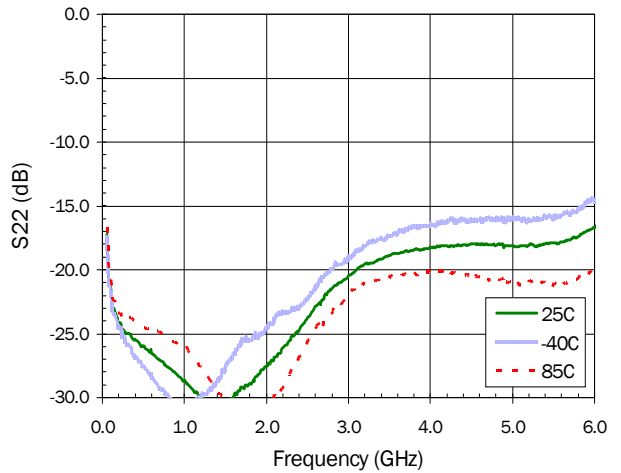

**NF versus Frequency**

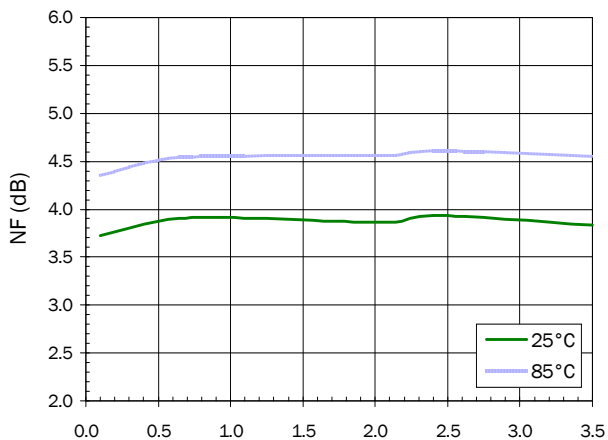

**DCIV**

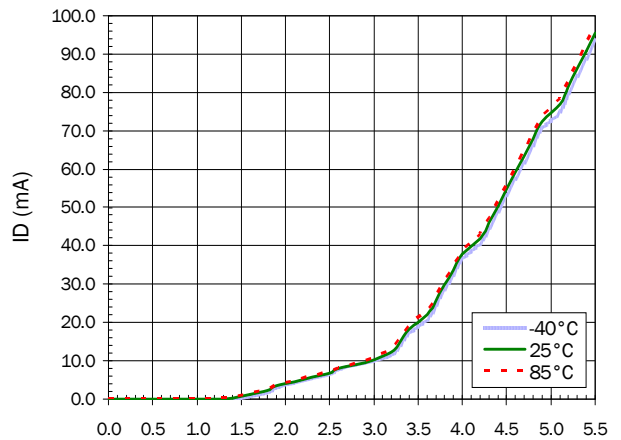

## Application Schematic

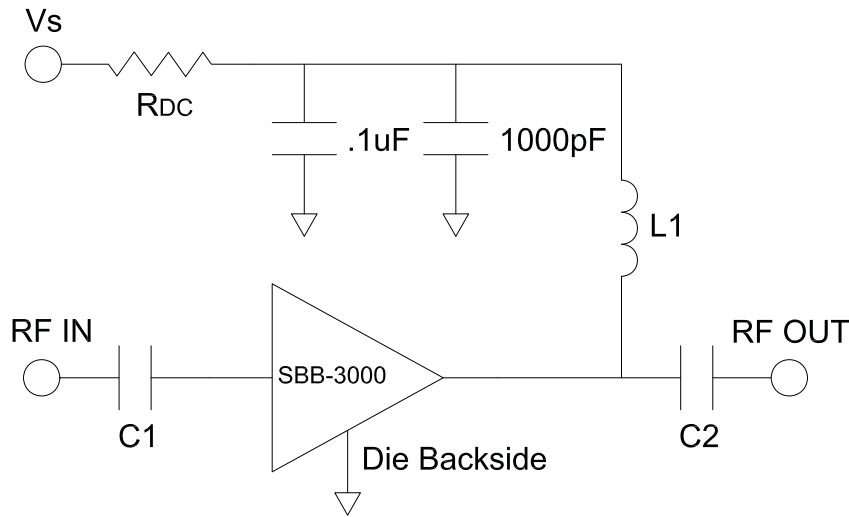

### Application Circuit Element Values

Reference Designator	500MHz to 3500MHz
C1	1000pF
C2	68pF
L1	48nH 0805HQ Coilcraft

### Recommended Bias Resistor Values for $I_D = 42\text{mA}$ , $R_{DC} = (V_S - V_D)/I_D$

Supply Voltage ( $V_S$ )	5V	6V	8V	10V	12V
$R_{DC}$	20 $\Omega$	43 $\Omega$	91 $\Omega$	139 $\Omega$	187 $\Omega$

**Pin Names and Descriptions**

Pin	Name	Description
	<b>RF IN</b>	RF input. An external DC blocking capacitor chosen for the frequency of operation is required.
	<b>DIE BACKSIDE</b>	Die backside must be connected to RF/DC ground using silver filled conductive epoxy.
	<b>RF OUT/ DC BIAS</b>	RF output and DC bias input. An external DC blocking capacitor chosen for the frequency of operation is required.

**Die Dimensions**

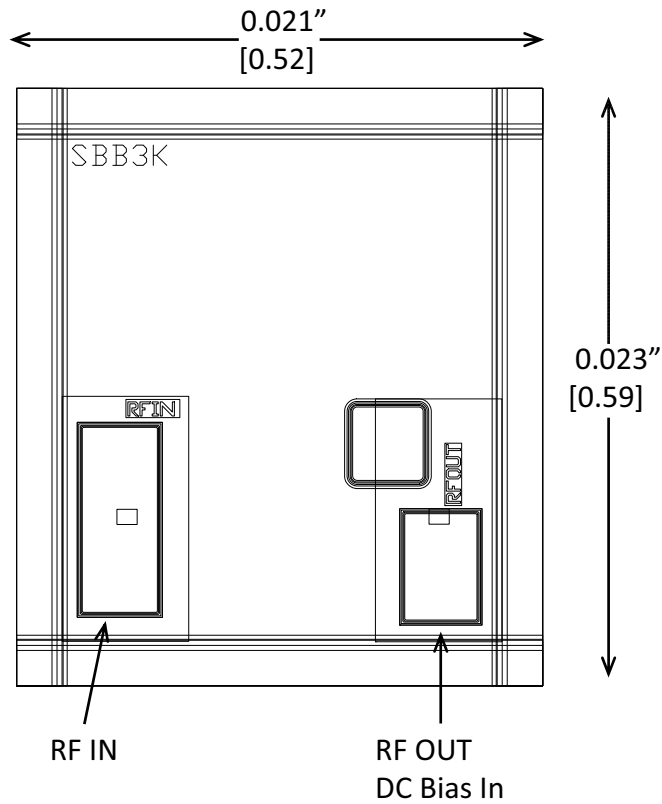

**Notes:**

1. All dimensions in inches [millimeters]
2. Die thickness: 0.004 [0.10]
3. Typical bond pad size is 0.003 x 0.007
4. Backside metallization: Gold
5. Bond pad metallization: Gold
6. Backside is ground

**Ordering Information**

Part Number	Description	Container	Quantity
SBB3000	Bare Die	Gel Pack	10
SBB3000S2	Bare Die	Gel Pack	2