



Product Description

The SGL0163Z is a high performance SiGe HBT MMIC low noise amplifier featuring one-micron emitters with FT up to 50GHz. This device has an internal temperature compensation circuit permitting operation directly from supply voltages as low as 2.5V. The SGL0163Z has been characterized at $V_D=3V$ for low power and 4V for medium power applications. Only two DC-blocking capacitors, a bias resistor, and an optional RF choke are required for operation from 800MHz to 1300MHz.

Features

- Internally Matched to 50Ω 800MHz to 1300MHz
- High Input/Output Intercept
- Low Noise Figure: 1.2dB Typ. at 900MHz
- Low Power Consumption
- Single Voltage Supply Operation
- Internal Temperature Compensation

Applications

- Receivers, GPS, RFID
- Cellular, Fixed Wireless, Land Mobile

Optimum Technology Matching® Applied

- GaAs HBT
- GaAs MESFET
- InGaP HBT
- SiGe BiCMOS
- Si BiCMOS
- SiGe HBT
- GaAs pHEMT
- Si CMOS
- Si BJT
- GaN HEMT
- InP HBT

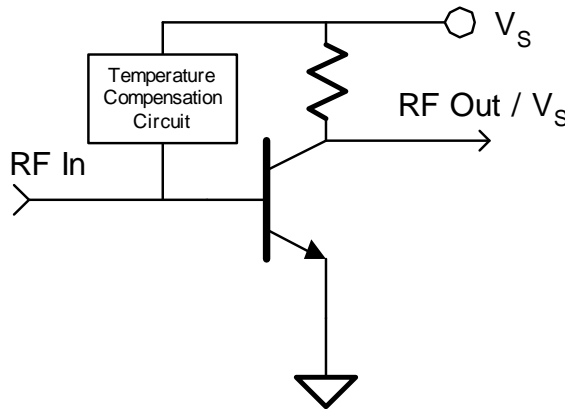

Parameter	Specification ($V_S=3V$)			Specification ($V_S=4V$)			Unit	Condition
	Min.	Typ.	Max.	Min.	Typ.	Max.		
Small Signal Gain		15.7			16.6		dB	800MHz
	14.0	15.5	17.0		15.8		dB	900MHz
		14.1			15.0		dB	1000MHz
Output Power at 1dB Compression		4.4			9.9		dBm	800MHz
	3.2	5.2			10.1		dBm	900MHz
		5.6			10.5		dBm	1000MHz
Input Third Order Intercept Point								Tone Spacing=1MHz P_{OUT} per tone=-13dBm
		5.3			12.1		dBm	800MHz
	5.0	7.0			13.4		dBm	900MHz
Noise Figure		1.1			1.6		dB	800MHz, $Z_S=50\Omega$
		1.2	1.7		1.7		dB	900MHz, $Z_S=50\Omega$
		1.2			1.7		dB	1000MHz, $Z_S=50\Omega$
Input Return Loss	10.0	12.5			15.7		dB	900MHz
Output Return Loss	11.5	15.6			17.6		dB	900MHz
Reverse Isolation		20.9			20.9		dB	900MHz
Device Current	9.5	12.0	14.0		23		mA	
Thermal Resistance		255					$^{\circ}C/W$	

Test Conditions: 800MHz to 1300 Application Circuit, $T_{LEAD}=25^{\circ}C$, $Z_0=Z_L=50\Omega$

Absolute Maximum Ratings

Parameter	Rating	Unit
Max Device Current (I_D)	45	mA
Max Device Voltage (V_S)	5	V
Max RF Input Power	+10	dBm
Max Junction Temp (T_J)	+150	°C
Operating Temp Range (T_{LEAD})	-40 to +85	°C
Max Storage Temp	+150	°C
ESD Rating - Human Body Model (HBM)	1A	Class
Moisture Sensitivity Level	1	MSL



Caution! ESD sensitive device.

Exceeding any one or a combination of the Absolute Maximum Rating conditions may cause permanent damage to the device. Extended application of Absolute Maximum Rating conditions to the device may reduce device reliability. Specified typical performance or functional operation of the device under Absolute Maximum Rating conditions is not implied.

The information in this publication is believed to be accurate and reliable. However, no responsibility is assumed by RF Micro Devices, Inc. ("RFMD") for its use, nor for any infringement of patents, or other rights of third parties, resulting from its use. No license is granted by implication or otherwise under any patent or patent rights of RFMD. RFMD reserves the right to change component circuitry, recommended application circuitry and specifications at any time without prior notice.



RFMD Green: RoHS compliant per EU Directive 2002/95/EC, halogen free per IEC 61249-2-21, < 1000ppm each of antimony trioxide in polymeric materials and red phosphorus as a flame retardant, and <2% antimony in solder.

Operation of this device beyond any one of these limits may cause permanent damage. For reliable continuous operation, the device voltage and current must not exceed the maximum operating values specified in the table on page one.

Bias Conditions should also satisfy the following expression:

$$I_D V_D < (T_J - T_{JL}) / R_{TH, j-l}$$

Device Voltage (V_D) vs. Device Current (I_D) Over Temperature
Load lines for $V_S = +5$ Volts, $R_{B2} = 43 \Omega$ and 180Ω

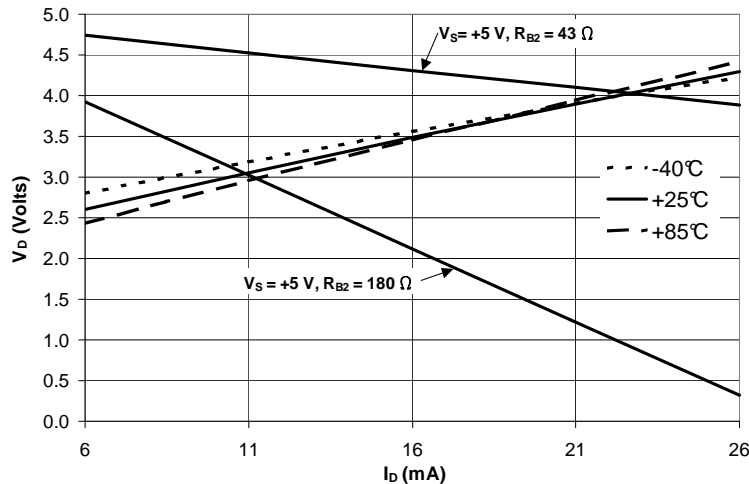

Typical RF Performance at $V_s = 3\text{ V}$ and 4 V -- 800-1300 MHz Evaluation Board -- $T_{LEAD} = +25^\circ\text{C}$

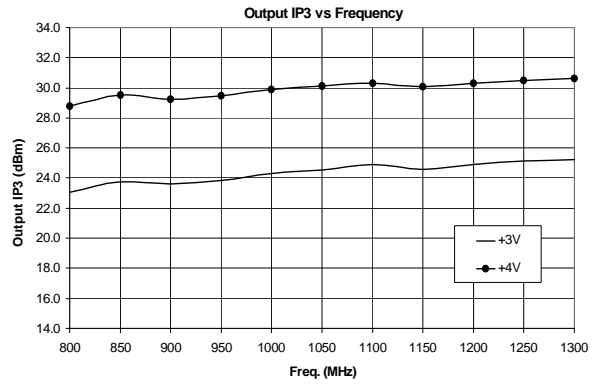
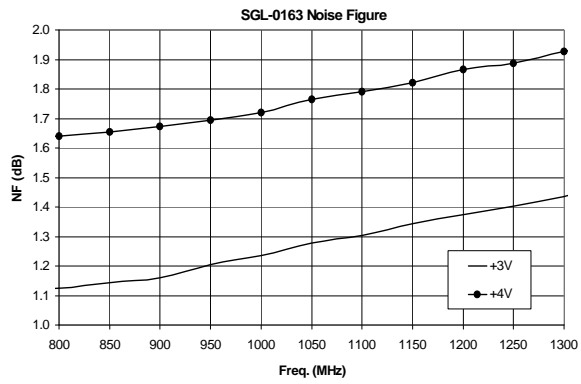
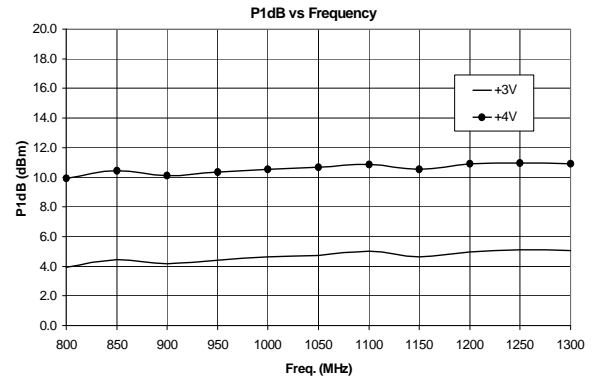
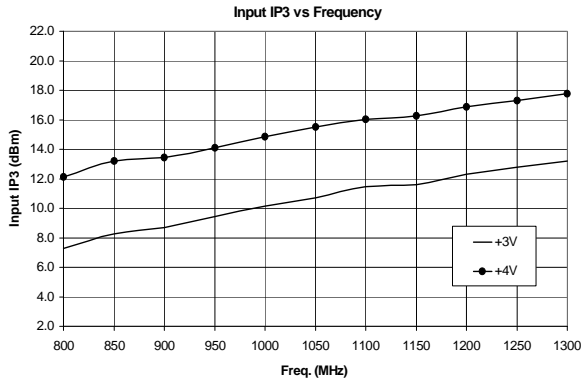

Typical RF Performance at $V_s = 3\text{ V}$ -- 800-1300 MHz Evaluation Board -- $T_{LEAD} = +25^\circ\text{C}$

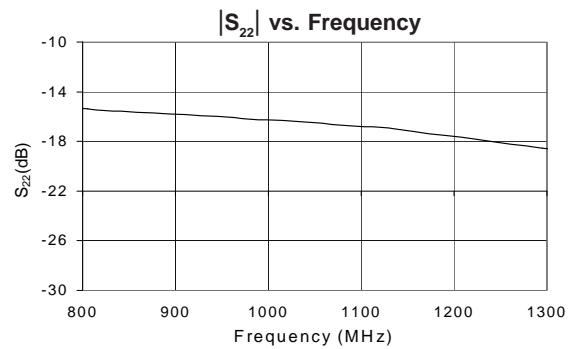
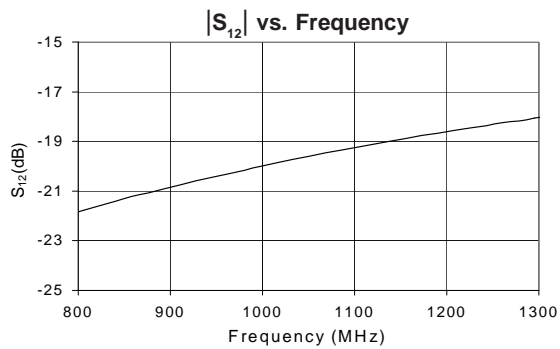
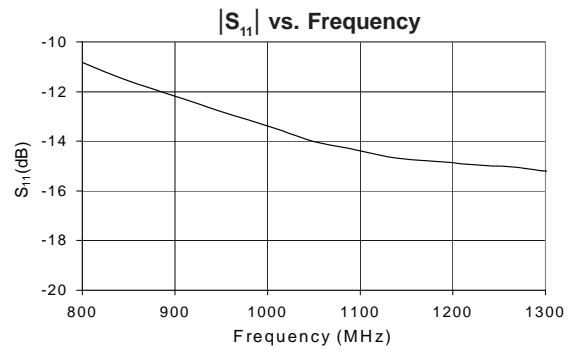
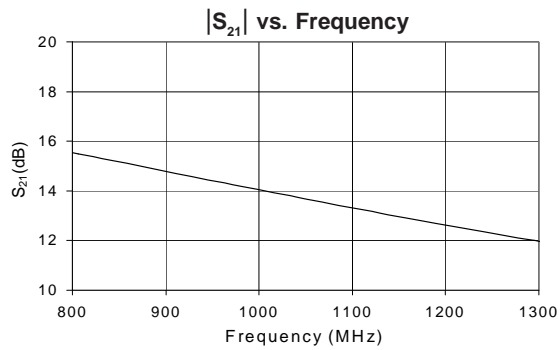

Typical RF Performance at $V_s = 4\text{ V}$ -- 800-1300 MHz Evaluation Board -- $T_{LEAD} = +25^\circ\text{C}$

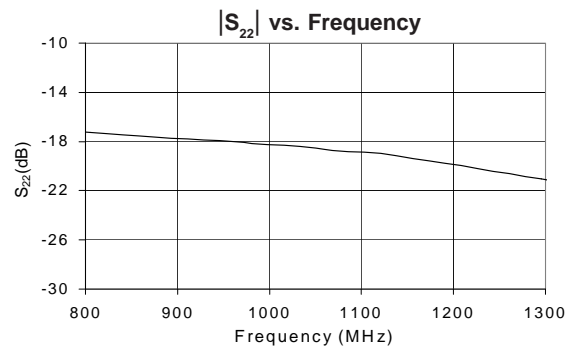
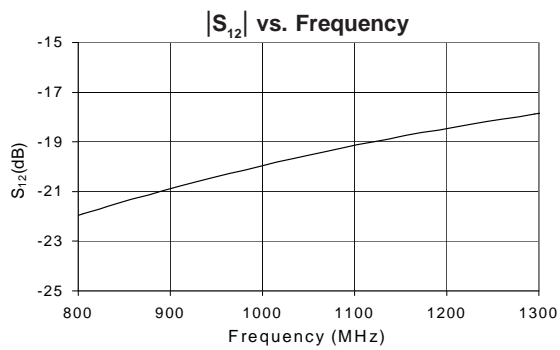
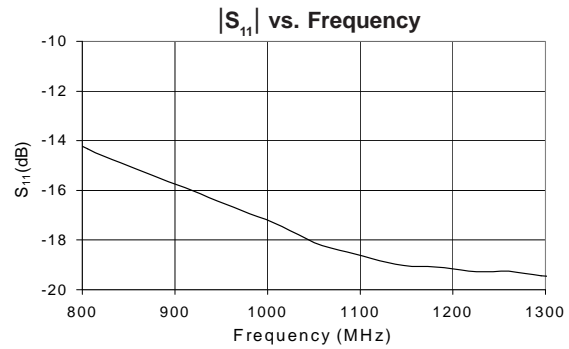
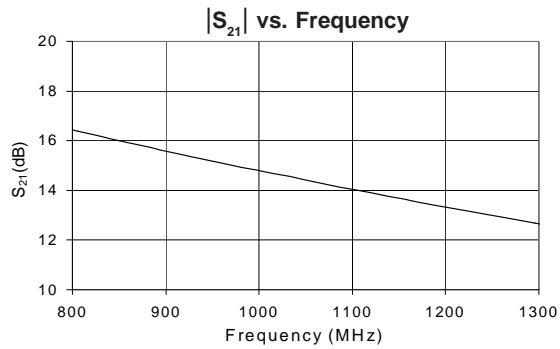

RF Performance - 400-500MHz Series L Application Circuit

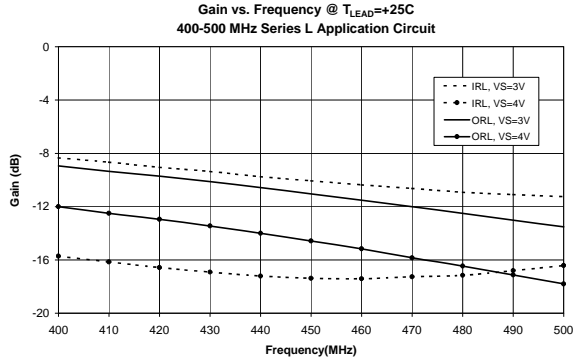
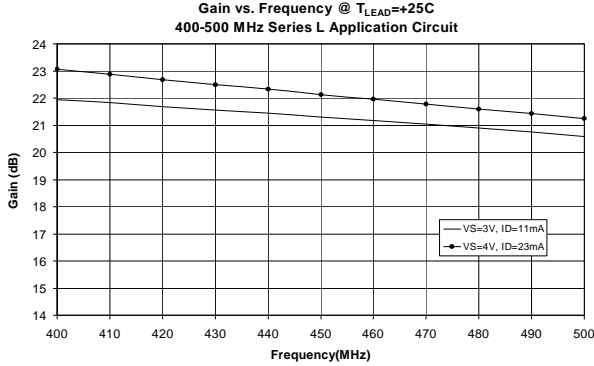

$V_S=3V, I_D=11mA$ (Typ.)					
Freq	Gain (dB)	P1dB (dBm)	IIP3 (dBm)	OIP3 (dBm)	NF (dB)
400 MHz	22.0	4.4	1.3	23.1	1.1
450 MHz	21.3	5.0	3.2	24.7	1.3
500 MHz	20.6	5.7	4.1	24.7	1.3
$V_S=4V, I_D=24mA$ (Typ.)					
Freq	Gain (dB)	P1dB (dBm)	IIP3 (dBm)	OIP3 (dBm)	NF (dB)
400 MHz	23.1	10.9	6.5	29.6	2.0
450 MHz	22.2	11.4	8.1	30.3	2.1
500 MHz	21.2	12.0	7.8	28.9	2.1

RF Performance - 100-800 MHz RC Feedback Application Circuit

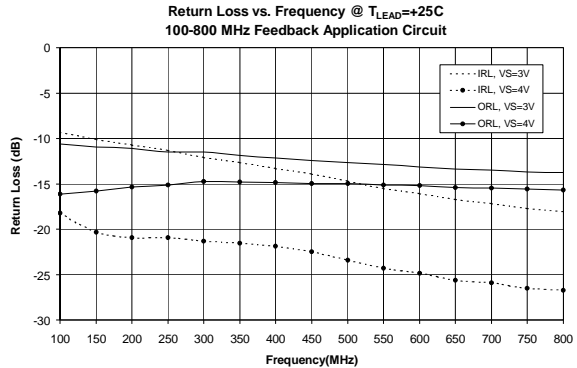
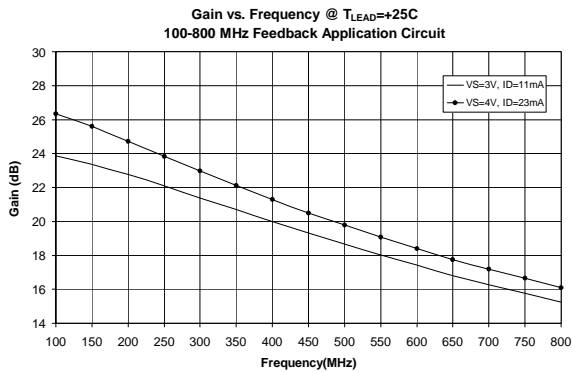

$V_S=3V, I_D=11mA$ (Typ.)					
Freq	Gain (dB)	P1dB (dBm)	IIP3 (dBm)	OIP3 (dBm)	NF (dB)
100 MHz	23.9	3.5	-6.8	17.1	1.4
300 MHz	21.4	3.4	-2.5	18.9	1.2
500 MHz	18.7	3.5	0.1	18.8	1.2
800 MHz	15.2	3.7	4.3	19.5	1.2
$V_S=4V, I_D=23mA$ (Typ.)					
Freq	Gain (dB)	P1dB (dBm)	IIP3 (dBm)	OIP3 (dBm)	NF (dB)
100 MHz	26.3	9.2	-4.1	22.2	2.2
300 MHz	23.0	9.8	2.2	25.1	1.9
500 MHz	19.8	9.9	5.2	25.0	1.7
800 MHz	16.1	10.0	9.7	25.8	1.7

100MHz to 800MHz Operation

The useful range of the SGL0163Z may be extended down to 100MHz using simple lumped element tuning. Following are two examples:

Option 1: A series inductor introduced at the input and output optimizes RF performance over 100MHz wide bands. Band center is selected by adjustment of the inductor values. the example is optimized for the 400MHz to 500MHz band.

Option 2: An RC feedback network provides broadband RF performance from 100MHz to 800MHz. The resistor value may be adjusted to select a combination of gain/NF/return loss best suited to the particular application.

Data and schematics for these two options are presented below.

Contact RFMD technical support for further guidance.

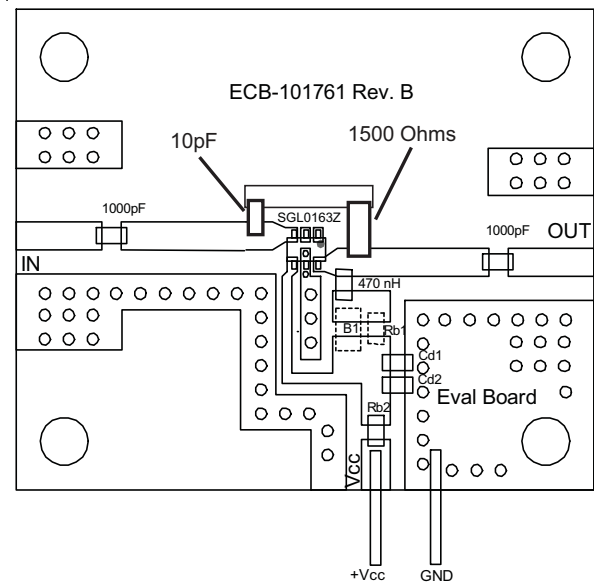
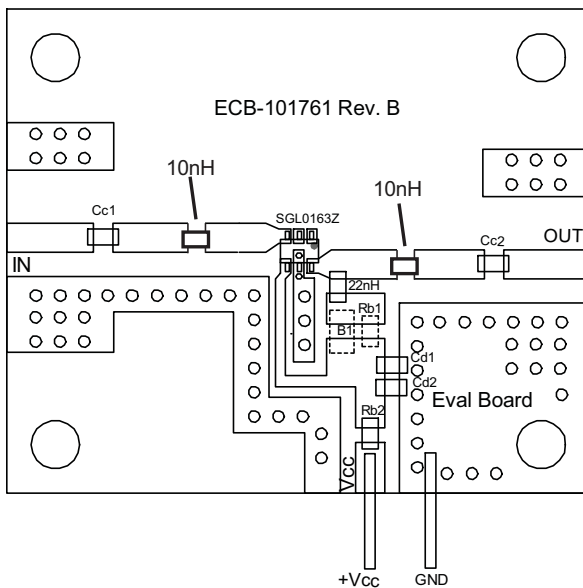

Bill of Materials for Evaluation Board, 100MHz to 800MHz

Ref. Designator	Description	Value	Manufacturer's Part Number
B1 ²	Ferrite Bead	1500Ω at 100MHz	Murata Electronics BLM18HE152SN1D
Cc1, Cc2, Cd1	Capacitor, SM, 0603	0.1uF	SAMSUNG CL10B103KBNC T/R
Cd2	Capacitor, SM, 0603	22 pF	ROHM MCH185AA220DJK
Rb1 ²	Resistor, SM, 0603	47 Ω	PHILLIPS 9C06031A47R0 JL HFT
Rb2	Resistor, SM, 0603	0Ω	PHILLIPS 9C06031A0R00 JL HFT
N/A ¹	Circuit Board	N/A	ECB101761 Rev B

Notes:

1. Circuit board dielectric material is GETEK, ML200C.
2. B1 and Rb1 recommended for improved K-factor but are optional. Replace with 0Ω resistor if not used.

Pin Names and Description

Pin	Function	Description
1	NC	No Electrical Connection. Provide an isolated (ungrounded) solder pad for mounting integrity.
2	GND	Connection to Ground. Provide via holes as close to the device ground leads as possible to reduce ground inductance and achieve optimum RF performance.
3	RF IN	RF Input Pin. This pin requires the use of an external DC blocking capacitor chosen for the frequency of operation.
4	DC BIAS	Voltage Supply Connection. Bypass with suitable capacitors.
5	GND	Connection to Ground. Provide via holes as close to the device ground leads as possible to reduce ground inductance and achieve optimum RF performance.
6	RF OUT/ BIAS	RF Output and Voltage Supply. DC voltage is present on this pin, therefore a DC blocking capacitor is necessary for proper operation.

SOT-363 PCB Pad Layout

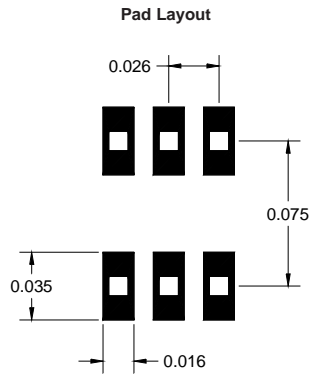

Notes:

1. Provide a ground pad area under device pins 2 & 5 with plated via holes to the PCB ground plane.
2. We recommend 1 or 2 ounce copper. Measurements for this data sheet were made on a 31 mil thick Getek with 1 ounce copper on both sides.

SOT-363 Nominal Package Dimensions

Dimensions in inches (millimeters)
Refer to drawing posted at www.rfmd.com for tolerances.

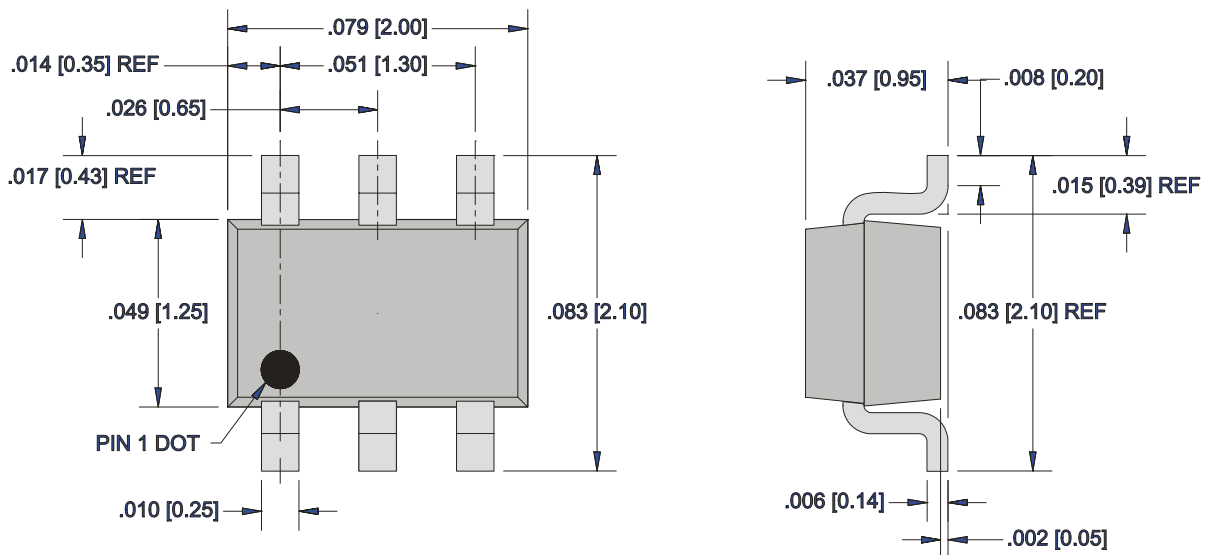

800MHz to 1300MHz Application Circuit

NOTE: Pin 1 must be electrically floating. Do not connect to ground. Provide an isolated solder pad for mounting integrity.

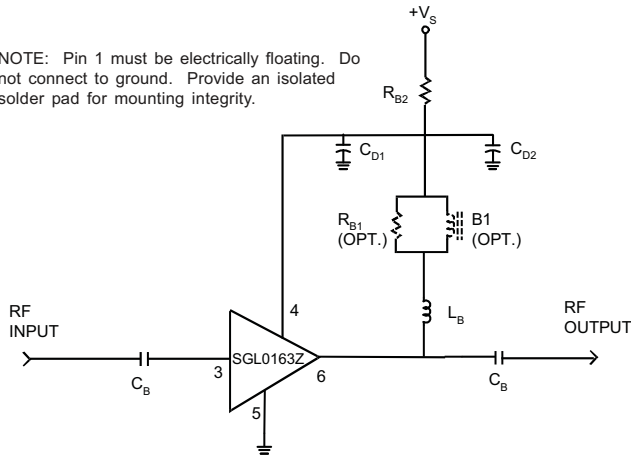

Application Circuit Element Values

Reference Designator	Value	Manufacturer & Part No.
L_B	33 nH	TOKO LL 1608-FSL33NJ
$B1$ ¹	1500 Ohms @100 MHz	FAIR-RITE 2508051527y0 Ferrite Bead
C_{B1}, C_{D1}	0.1 μ F	SAMSUNG CL10B103KBNC
C_{D2}	22 pF	ROHM MCH185AA220DJK
R_{B1} ¹	47 Ohms	PHILLIPS 9C06031A47R0 JL HFT
R_{B2} ²	0 Ohms	PHILLIPS 9C06031A0R00 JL HFT

Notes:

- $B1$ and R_{B1} provide improved K-factor but are optional.
- R_{B2} may be introduced as a voltage dropping resistor for use with supply voltages greater than the desired device bias voltage.

Evaluation Board Layout

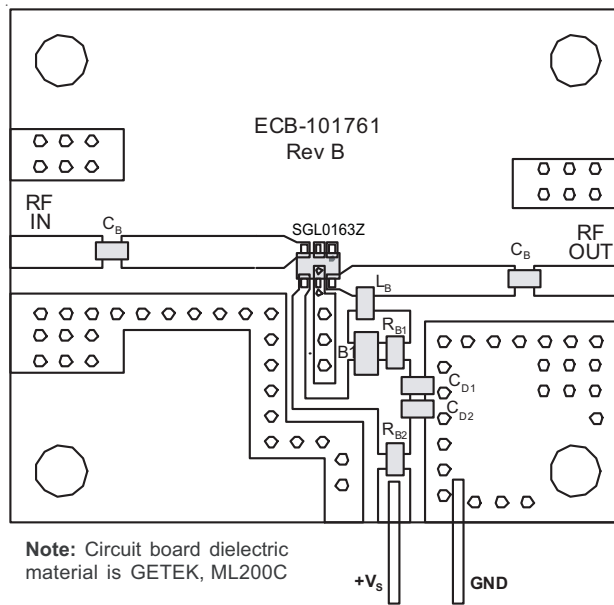

Part Identification Marking

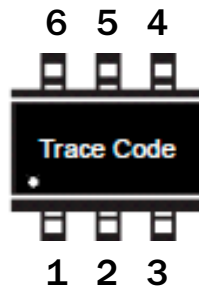

Ordering Information

Part Number	Description
SGL0163Z	7" Reel with 3000 pieces
SGL0163ZSQ	Sample Bag with 25 pieces
SGL0163ZSR	7" Reel with 100 pieces
SGL0163ZPCK1	800MHz to 1300MHz PCBA with 5-piece Sample Bag