



Features

- Low Noise and High Intercept Point
- Adjustable Bias for Enhanced IP3
- Single 2.5V to 6.0V Power Supply
- 400MHz to 3800MHz Operation
- QFN16, 3mmx3mm Package

Applications

- GSM/EDGE, CDMA, PCS, UMTS LNA/Linear Driver
- WLAN LNA/Linear Driver
- WiMAX LNA/Linear Driver
- 900MHz LNA/Linear Driver
- General Purpose Amplification

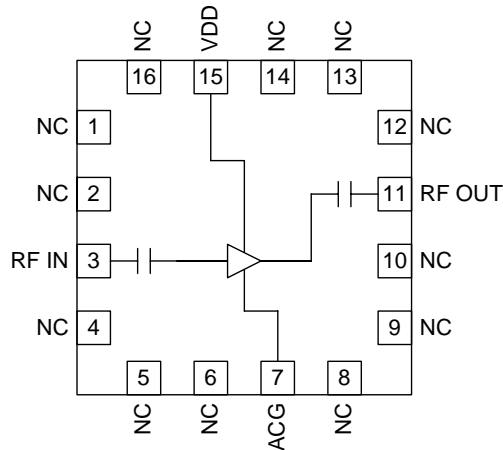

Functional Block Diagram

Product Description

The RF3861 is a low noise amplifier with a high output IP3. The amplifier is self-biased from a single voltage supply with 50Ω input and output ports. The useful frequency range is from 400MHz to 3800MHz. A 1dB noise figure and 36dBm OIP3 performance is achieved with a 5V V_{DD}, 90mA. Current can be increased to raise OIP3 while having minimal effect on noise figure. The IC is featured in a standard QFN, 16-pin, 3mmx3mm package.

Ordering Information

RF3861	Wide Bandwidth, High Linearity Low Noise Amplifier
RF3861PCK-410	Fully Assembled Evaluation Board with 5 Sample Parts 1.5GHz to 2.7 GHz

Optimum Technology Matching® Applied

- | | | | |
|--------------------------------------|--------------------------------------|--|-----------------------------------|
| <input type="checkbox"/> GaAs HBT | <input type="checkbox"/> SiGe BiCMOS | <input checked="" type="checkbox"/> GaAs pHEMT | <input type="checkbox"/> GaN HEMT |
| <input type="checkbox"/> GaAs MESFET | <input type="checkbox"/> Si BiCMOS | <input type="checkbox"/> Si CMOS | <input type="checkbox"/> RF MEMS |
| <input type="checkbox"/> InGaP HBT | <input type="checkbox"/> SiGe HBT | <input type="checkbox"/> Si BJT | <input type="checkbox"/> LDMOS |

RF MICRO DEVICES®, RFMD®, Optimum Technology Matching®, Enabling Wireless Connectivity™, PowerStar®, POLARIS™ TOTAL RADIO™ and UltimateBlue™ are trademarks of RFMD, LLC. BLUETOOTH is a trademark owned by Bluetooth SIG, Inc., U.S.A. and licensed for use by RFMD. All other trade names, trademarks and registered trademarks are the property of their respective owners. ©2006, RF Micro Devices, Inc.

Absolute Maximum Ratings

Parameter	Rating	Unit
Supply Voltage	6V	V _{DC}
Input RF Level	+10	dBm
Current Drain, I _{DD}	150	mA
Operating Ambient Temperature	-40 to +85	°C
Storage Temperature	-40 to +150	°C

Note 1: Max continuous RF IN is +10dBm. The max transient RF IN is +20dBm.



Caution! ESD sensitive device.

Exceeding any one or a combination of the Absolute Maximum Rating conditions may cause permanent damage to the device. Extended application of Absolute Maximum Rating conditions to the device may reduce device reliability. Specified typical performance or functional operation of the device under Absolute Maximum Rating conditions is not implied.

RoHS status based on EUDirective2002/95/EC (at time of this document revision).

The information in this publication is believed to be accurate and reliable. However, no responsibility is assumed by RF Micro Devices, Inc. ("RFMD") for its use, nor for any infringement of patents, or other rights of third parties, resulting from its use. No license is granted by implication or otherwise under any patent or patent rights of RFMD. RFMD reserves the right to change component circuitry, recommended application circuitry and specifications at any time without prior notice.

Parameter	Specification			Unit	Condition
	Min.	Typ.	Max.		
High Band					
Frequency	3.3	3.5	3.8	GHz	V _{DD} = 5V
Current		90	110	mA	
Gain		10		dB	At 3.5GHz
Noise Figure		1.1		dB	+25 °C, V _{DD} = 5V, I _{DD} = 90mA, 3500MHz unless specified
OIP3		37.0		dBm	
OP1dB		22.0		dBm	
S11		-12		dB	f ₁ = 3500MHz, f ₂ = 3501MHz
S22		-18		dB	
Mid Band					
Frequency	1500		2700	MHz	
Current		90	110	mA	V _{DD} = 5V
Gain	13.5	14.5	16.5	dB	+25 °C, V _{DD} = 5V, I _{DD} = 90mA, 2000MHz unless specified
Noise Figure		1.0	1.2	dB	
OIP3	33.0	35.5		dBm	f ₁ = 2000MHz, f ₂ = 2001MHz
OP1dB	21.0	22.5	25.0	dBm	
S11		-10		dB	
S22		-20		dB	
Low Band					
Frequency	700		1100	MHz	
Current		90	110	mA	V _{DD} = 5V
Gain		16		dB	+25 °C, V _{DD} = 5V, I _{DD} = 90mA, 850MHz unless specified
Noise Figure		1.2		dB	
OIP3		36.0		dBm	f ₁ = 850MHz, f ₂ = 851MHz
OP1dB		22.5		dBm	
S11		-14		dB	
S22		-18		dB	
Thermal					
Theta _{JC}		51		°C/W	
Power Supply					
Device Operating Voltage	2.5	5.0	6.0	V	
Operating Current	65	90	110	mA	V _{DD} = 5.0V, R2 = open

Pin	Function	Description	Interface Schematic
1	NC	Not connected.	
2	NC	Not connected.	
3	RF IN	RF input pin. 50Ω matched. This pin is DC-blocked.	
4	NC	Not connected.	
5	NC	Not connected.	
6	NC	Not connected.	
7	ACG	AC ground. Shunt cap may be added for tuning. Shunt resistor may be added to increase I _{DD} /IP ₃ .	
8	NC	Not connected.	
9	NC	Not connected.	
10	NC	Not connected.	
11	RF OUT	RF output pin. 50Ω matched. This pin is DC-blocked.	
12	NC	Not connected.	
13	NC	Not connected.	
14	NC	Not connected.	
15	VD	Bias voltage. 2.5V to 6.0V applied through bias inductor.	
16	NC	Not connected.	
Pkg Base	GND	Ground connection.	

Package Drawing

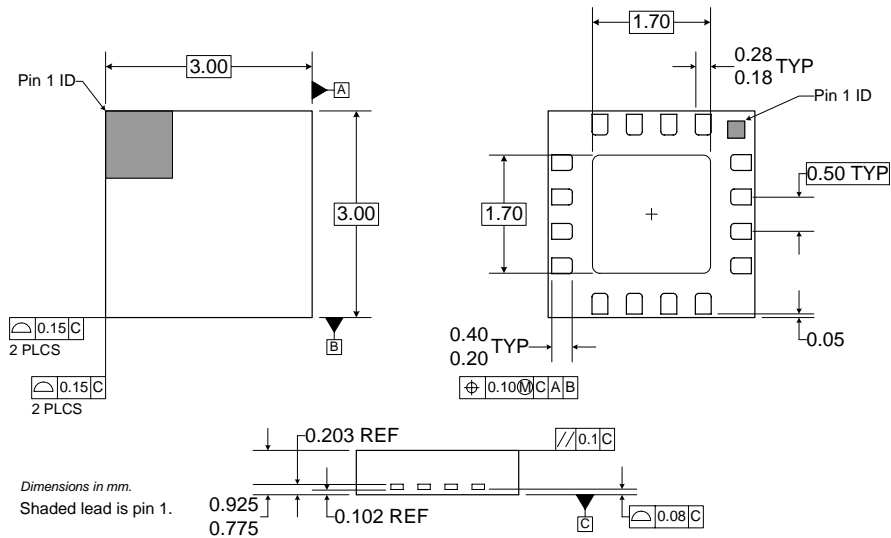

Application Schematic 400MHz to 1300MHz

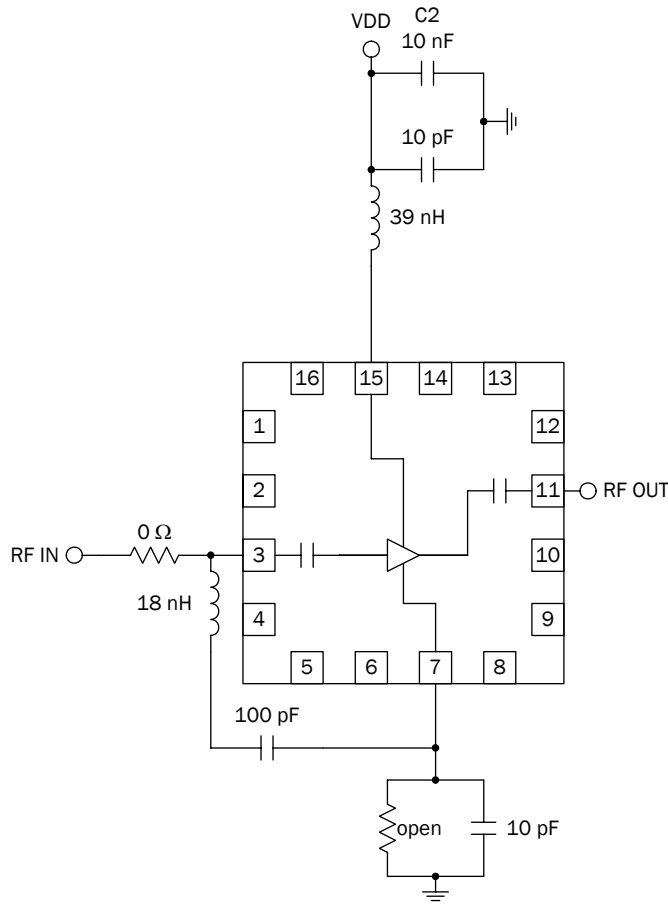

FREQ	VCC	NF	GAIN	OIP3	OP1dB
MHz	Volts	dB	dB	dBm	dBm
400	5	1.7	15.23	35.45	21.27
600	5	1.4	15.81	37.33	21.84
800	5	1.2	16.49	36.56	22.05
1000	5	1.1	16.7	36.22	22.02
1300	5	1.1	15.28	36.88	22.19

Note: This schematic is equivalent to standard 700 MHz to 1100 MHz evaluation board. Specification in above table shows tested performance over extended frequency range. See Theory of Operation section for details.

**Application Schematic
800 MHz to 2200 MHz**

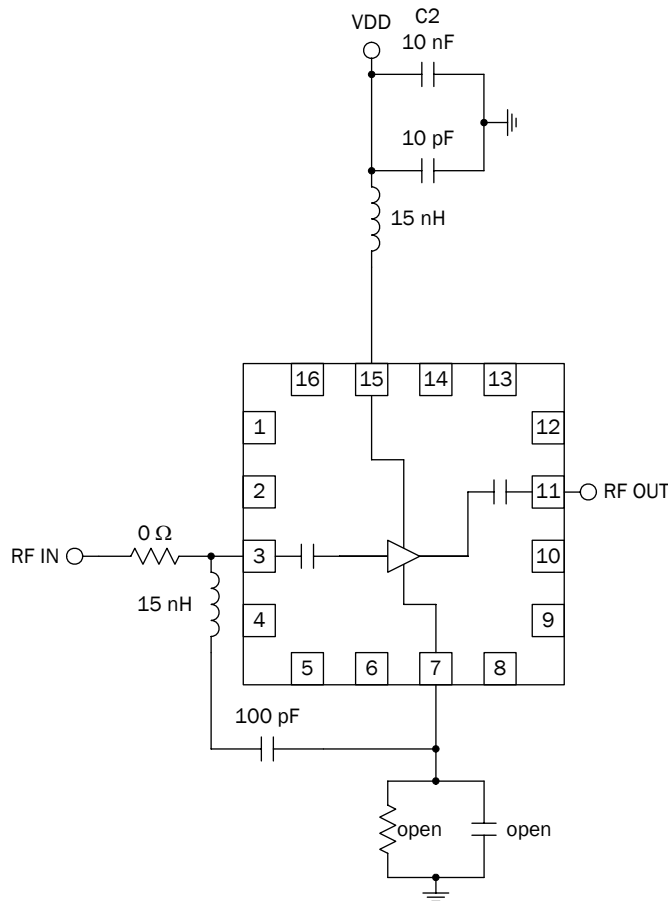

FREQ	VCC	NF	GAIN	OIP3	OP1dB
MHz	Volts	dB	dB	dBm	dBm
800	5	1.3	16	36	22
2200	5	0.9	13.9	36	22

Evaluation Board Schematic 700MHz to 3800MHz

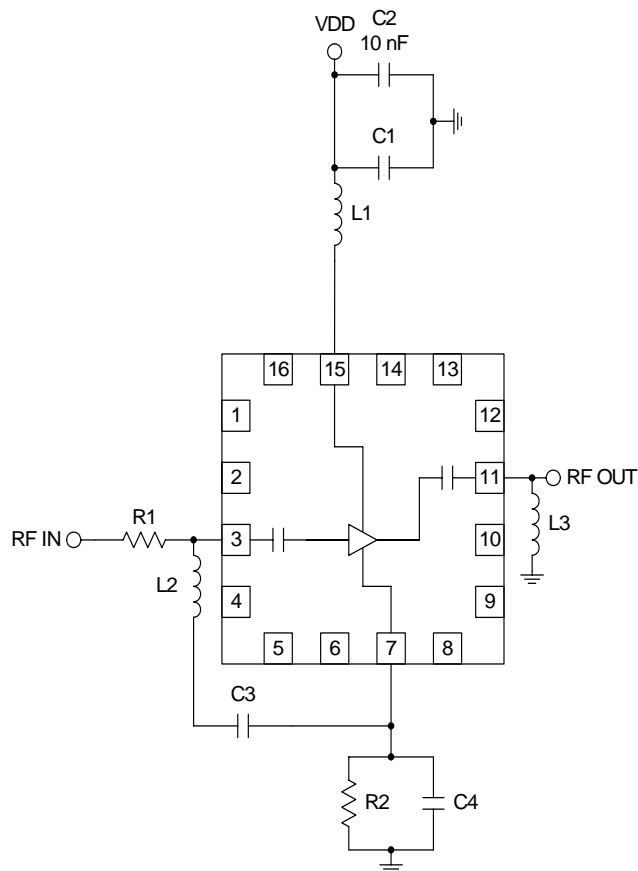

Components	700-1100 MHz	1.5-2.7 GHz	3.3-3.8 GHz
C1 (pF)	10	10	10
C3 (pF)	100	100	100
C4 (pF)	10	DNP	DNP
L1 (nH)	39	3.9	2.2
L2 (nH)	18	4.7	4.7
R1 (ohm)	0	0	0
R2 (ohm)	DNP	DNP	DNP
L3 (nH)	DNP	DNP	DNP

R2 is DNP for standard 90 mA current draw. If R2 is added, the I_{DD} will increase. A 20 Ω R2 will raise the current to achieve higher linearity.

5V Noise Figure versus Temperature

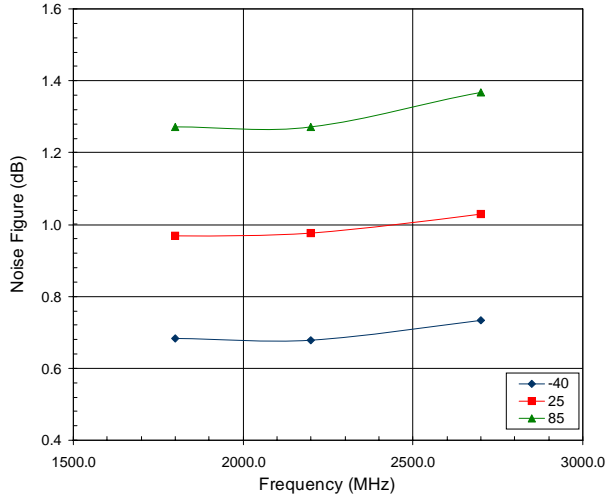

5V Gain versus Temperature

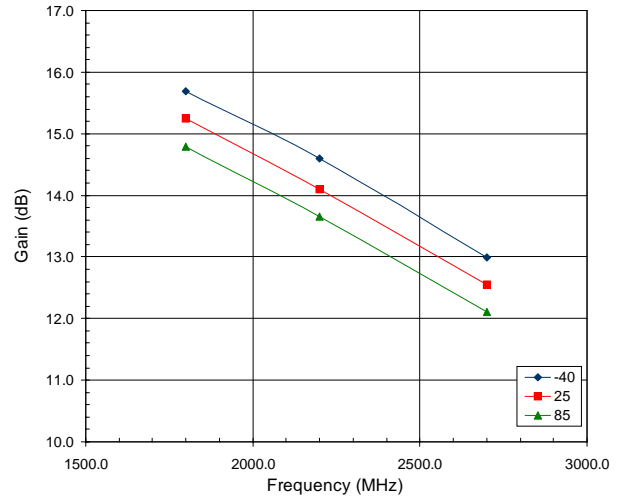

5V OIP3 versus Temperature

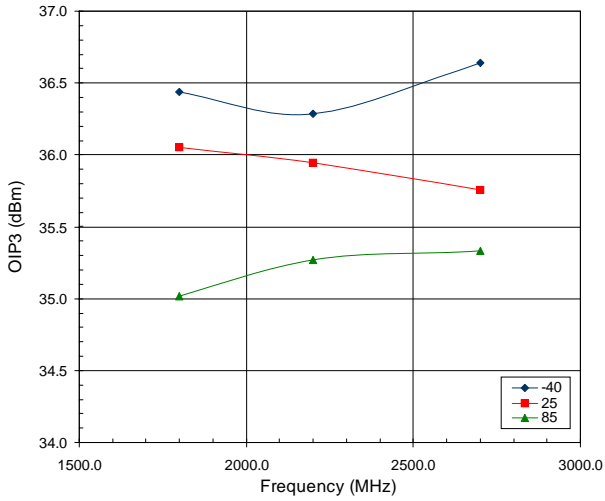

5V P1dB versus Temperature

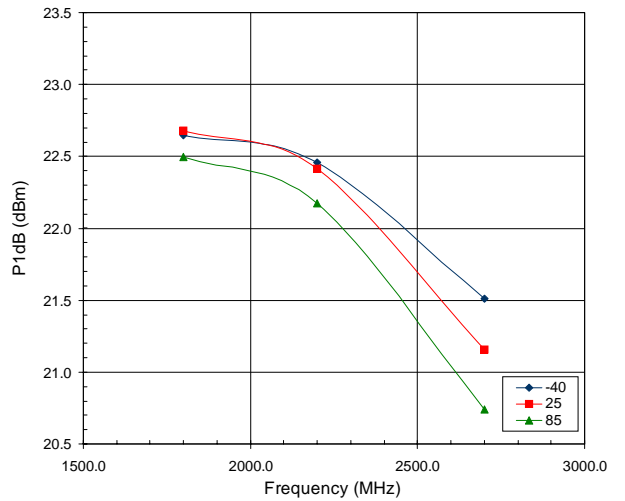

5V Noise Figure versus Temperature

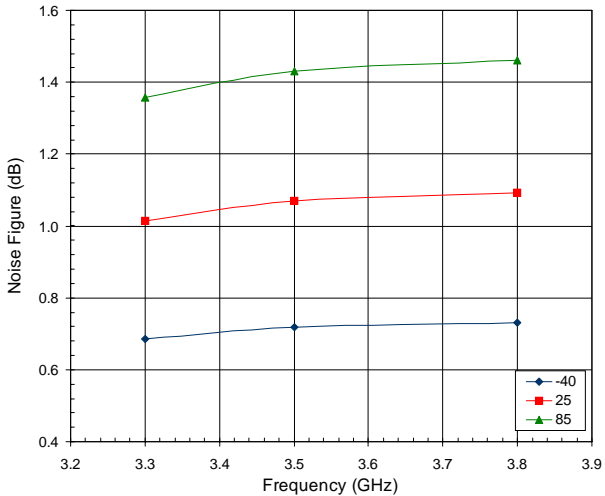

5V Gain versus Temperature

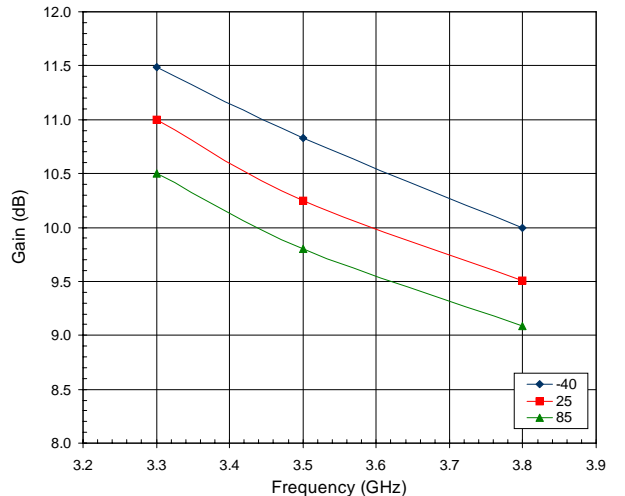

5V OIP3 versus Temperature

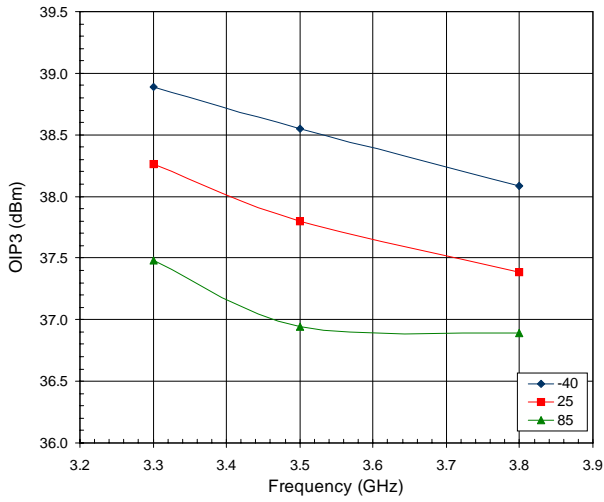

5V P1dB versus Temperature

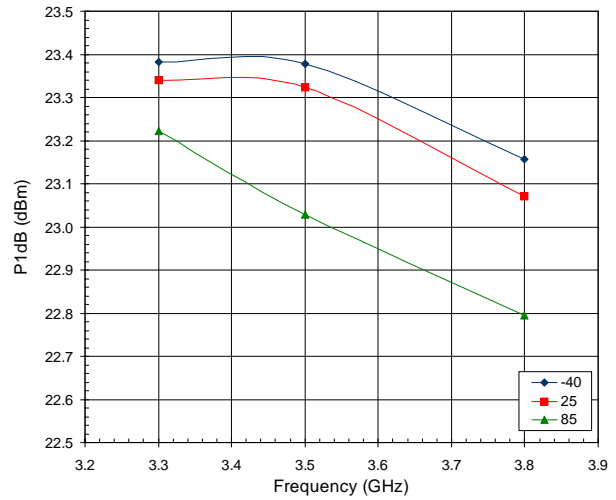

410 Evaluation Board, OIP3 versus R2 value

V_{DD}=5.0V Optimum OIP3 enhancement at R2=20 Ohm

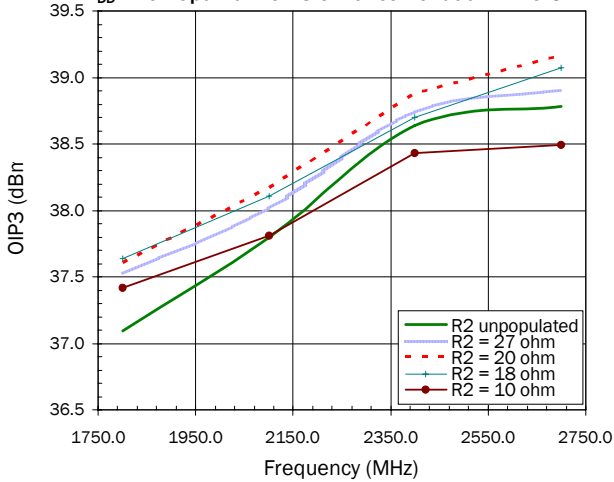

RF3861 I_{cc} vs R2

V_{DD} = 5.0 V

R2 = 20 ohm for optimal OIP3

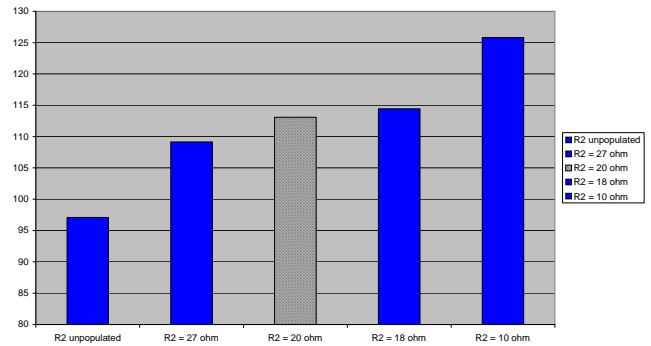

Theory of Operation

Low noise figure/high IP3 make RF3861 ideal for use as both receive LNA and transmit driver for cellular/DCS/PCS/UMTS and WiMax platforms, in addition to many other general purpose applications. Standard evaluation boards cover 700MHz to 1100MHz, 1500MHz to 2700MHz, and 3300MHz to 3800MHz. Viewing the data sheet evaluation board schematic, refer to below for purpose/function of external components:

- R1/L3 (0 Ω /unpopulated on standard evaluation boards): These unused components were placed for convenience and flexibility when needed to optimize matching for an out of band application.
- L2/C3/C4: Placed to optimize input match, and enhance out of band low frequency stability.
- R2: Optionally placed to increase bias current and IP3. It has been found that 20 Ω value is best case (see graph section of data sheet).
- L1/C1: Influence output return loss.

RF3861 has internal DC blocking capacitors at RFin/RFout. In addition, it has been shown impedance seen looking out at pins 7/15 influence response. As a result, two port s-parameters become non-applicable. In the event matching is desired for frequency bands outside of those provided with standard evaluation boards, the following approach can be used:

- Start with matching seen for standard evaluation board closest to desired band of operation.
- Optimize values at L2/C4/L1 to obtain response/performance.

The application schematic section of data sheet shows matching arrived at using above procedure, for 400MHz to 1300MHz and 800MHz to 2200MHz. These schematics, along with standard evaluation boards, cover 82% of the useable bandwidth from 400MHz to 3800MHz.

One interesting note concerning these application schematics, the 400MHz to 1300MHz example shows same component values as seen with 700MHz to 1100MHz evaluation board. So, it is, in actuality, the same board. The specification chart next to the schematic simply extends the frequency band by 500MHz. Input and output return losses are better than 10dB over the entire 900MHz bandwidth.

