



Features

- Frequency Range 400MHz to 2700MHz
- Mode Pin to Switch the Attenuation Slope
- Gain = 25dB Typical
- Gain Control Range = >30dB
- ACPR > -60dBc Typical at +10dBm P_{OUT} (Dual Carrier WCDMA)
- Small 5.2mm x 5.2mm, Multi-Chip Module
- +5V Supply

Applications

- Cellular, 3G Infrastructure
- WiBro, WiMax, LTE
- Microwave Radio
- High Linearity Power Control

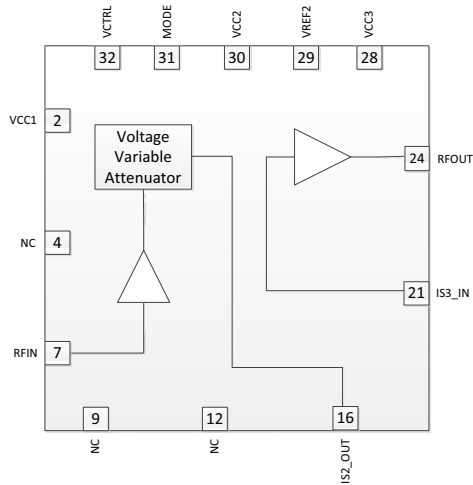

Functional Block Diagram

Product Description

RFMD's RFVA0016 is an integrated analog controlled variable gain amplifier for broadband applications with external matching to allow for configurations in different bands with a single module. It features exceptional linearity over a greater than 30dB gain control range. This variable gain amplifier is controlled by a single 0V to 3.3V positive supply voltage when mode pin is 0V or 5V to 0V positive supply voltage when mode pin is 5V. The RFVA0016 is packaged in a small 5.2mm x 5.2mm leadless laminate MCM which contains thermal vias for ultra-low thermal resistance. This module is external matched to 50Ω at each individual band.

Ordering Information

RFVA0016SQ	Sample bag with 25 pieces
RFVA0016SR	7" Sample reel with 100 pieces
RFVA0016TR7	7" Reel with 750 pieces
RFVA0016TR13	13" Reel with 2500 pieces
RFVA0016PCK-410	2620MHz to 2690MHz PCBA with 5-piece sample bag

Optimum Technology Matching® Applied

- | | | | |
|---|--------------------------------------|-------------------------------------|---|
| <input checked="" type="checkbox"/> GaAs HBT | <input type="checkbox"/> SiGe BiCMOS | <input type="checkbox"/> GaAs pHEMT | <input type="checkbox"/> GaN HEMT |
| <input type="checkbox"/> GaAs MESFET | <input type="checkbox"/> Si BiCMOS | <input type="checkbox"/> Si CMOS | <input type="checkbox"/> BIFET HBT |
| <input checked="" type="checkbox"/> InGaP HBT | <input type="checkbox"/> SiGe HBT | <input type="checkbox"/> Si BJT | <input checked="" type="checkbox"/> LDMOS |

RF MICRO DEVICES®, RFMD®, Optimum Technology Matching®, Enabling Wireless Connectivity™, PowerStar®, POLARIS™ TOTAL RADIO™ and UltimateBlue™ are trademarks of RFMD, LLC. BLUETOOTH is a trademark owned by Bluetooth SIG, Inc., U.S.A. and licensed for use by RFMD. All other trade names, trademarks and registered trademarks are the property of their respective owners. ©2012, RF Micro Devices, Inc.

Absolute Maximum Ratings

Parameter	Rating	Unit
Supply Voltage	5.5	V _{DC}
Control Voltage	5.5	V _{DC}
DC Supply Current	200	mA
Operating Temperature (T _{CASE})	-40 to +85	°C
Storage Temperature	-40 to +150	°C
Junction Temperature	150	°C
ESD Rating (HBM)	>1000 Class 1C	V
ESD Rating (CDM)	>1000 Class IV	V
Thermal Resistance (R _{TH})	59.6	°C/W



Caution! ESD sensitive device.

Exceeding any one or a combination of the Absolute Maximum Rating conditions may cause permanent damage to the device. Extended application of Absolute Maximum Rating conditions to the device may reduce device reliability. Specified typical performance or functional operation of the device under Absolute Maximum Rating conditions is not implied.

The information in this publication is believed to be accurate and reliable. However, no responsibility is assumed by RF Micro Devices, Inc. ("RFMD") for its use, nor for any infringement of patents, or other rights of third parties, resulting from its use. No license is granted by implication or otherwise under any patent or patent rights of RFMD. RFMD reserves the right to change component circuitry, recommended application circuitry and specifications at any time without prior notice.



RFMD Green: RoHS compliant per EU Directive 2002/95/EC, halogen free per IEC 61249-2-21, < 1000ppm each of antimony trioxide in polymeric materials and red phosphorus as a flame retardant, and <2% antimony in solder.

Parameter	Specification			Unit	Condition
	Min.	Typ.	Max.		
728MHz to 746MHz Frequency Band					All specifications for 25 °C, 5V, unless otherwise stated.
Gain	24	29		dB	
Adjustment Range	30	35		dB	
Output IP3		41		dBm	Max gain
Output P1dB		25		dBm	Max gain
ACPR		-65	-62	dBc	Dual carrier WCDMA, 7.5dB CF at nominal operating output power of 10dBm
Gain Flatness		0.3		dB	Over 50MHz BW
Control Voltage	0		3.3	V	Mode Pin = 0V
Noise Figure		5		dB	Min attenuator setting
Impedance		50		Ω	
Input Return Loss		18		dB	
Output Return Loss		12.5		dB	
2110MHz to 2170MHz Frequency Band					All specifications for 25 °C, 5V, unless otherwise stated.
Gain	24	26		dB	
Adjustment Range	35	40		dB	
Output IP3		40		dBm	Max gain
Output P1dB		24		dBm	Max gain
ACPR		-65	-62	dBc	Dual carrier WCDMA, 7.5dB CF at nominal operating output power of 10dBm
Gain Flatness		0.3		dB	Over 50MHz BW
Control Voltage	0		3.3	V	Mode Pin = 0V
Noise Figure		5		dB	Min attenuator setting
Impedance		50		Ω	
Input Return Loss		21		dB	
Output Return Loss		16		dB	

Parameter	Specification			Unit	Condition
	Min.	Typ.	Max.		
2620MHz to 2690MHz Frequency Band					All specifications for 25 °C, 5V, unless otherwise stated.
Gain	22	24		dB	
Adjustment Range	37	45		dB	
Output IP3		40		dBm	Max gain
Output P1dB		24		dBm	Max gain
ACPR		-65	-62	dBc	Dual carrier WCDMA, 7.5dB CF at nominal operating output power of 10dBm
Gain Flatness		0.25		dB	Over 50MHz BW
Control Voltage	0		3.3	V	Mode Pin = 0V
Noise Figure		4.9		dB	Min attenuator setting
Impedance		50		Ω	
Input Return Loss		21		dB	
Output Return Loss		18		dB	
Power Supply					Temp = 25 °C, V _{CC} = 5V, standard application circuit
Supply Voltage	4.75	5	5.25	V	
Gain Control Voltage	0		3.3	V	Mode Pin = 0V
	5		0	V	Mode Pin = 5V
Current	140	185	218	mA	

Typical Performance: 728MHz to 746MHz Application Circuit

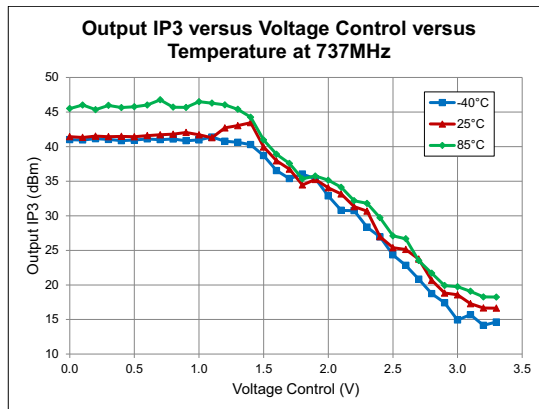
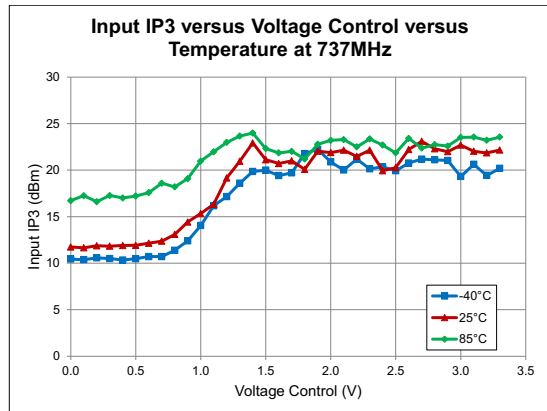
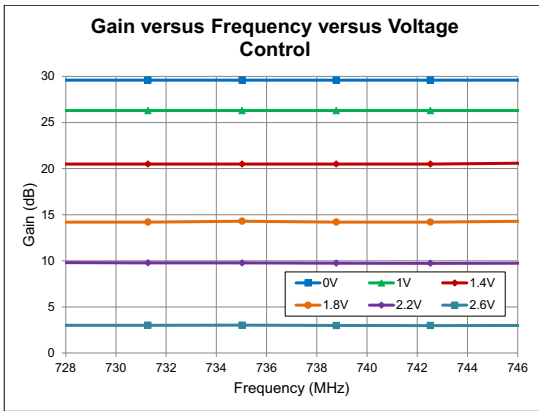
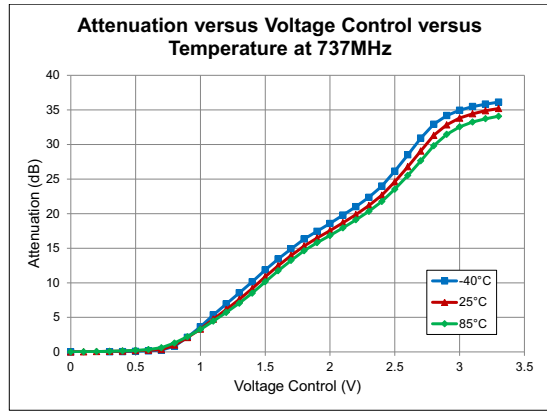
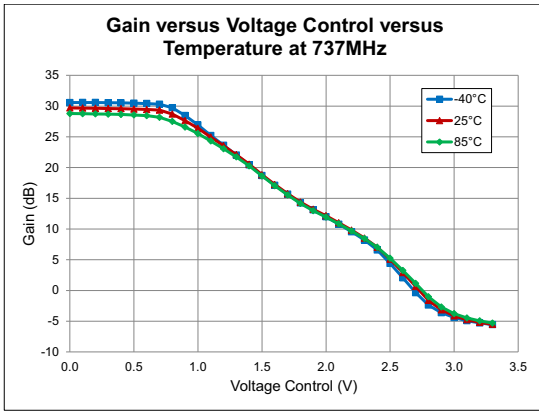

Typical Performance: 728MHz to 746MHz Application Circuit

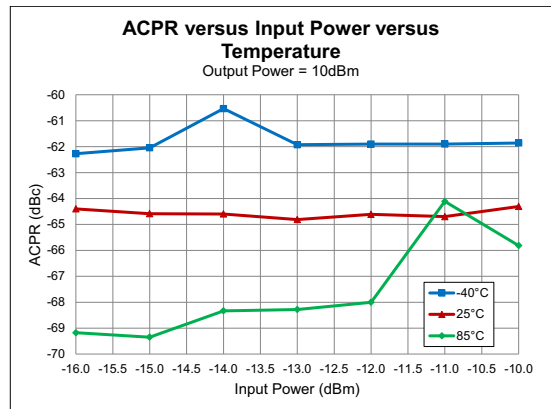
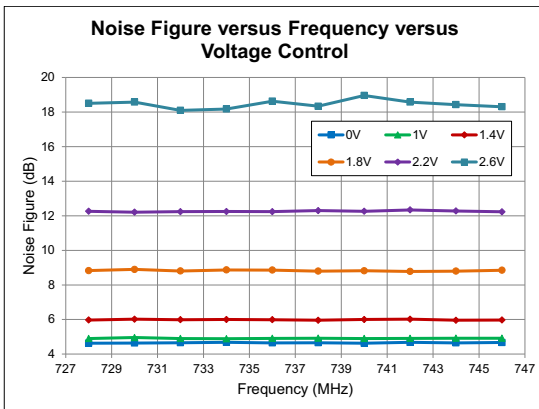
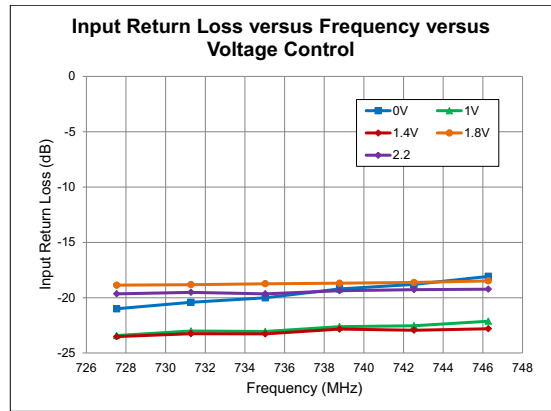
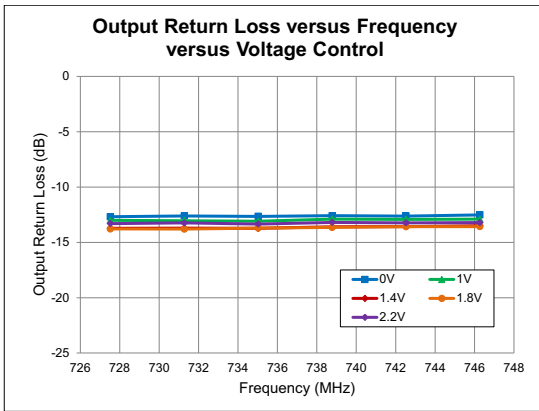
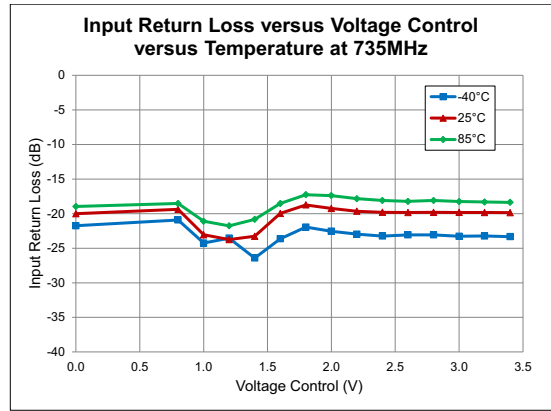
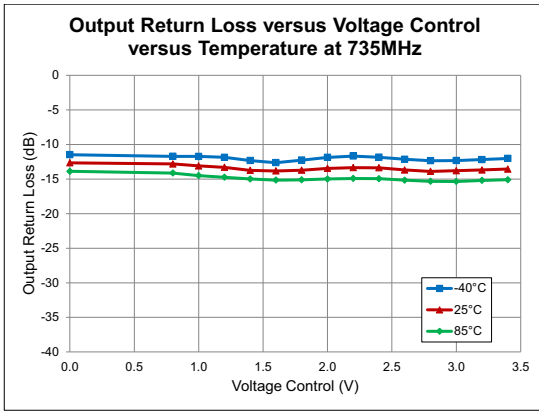

Typical Performance: 2110MHz to 2170MHz Application Circuit

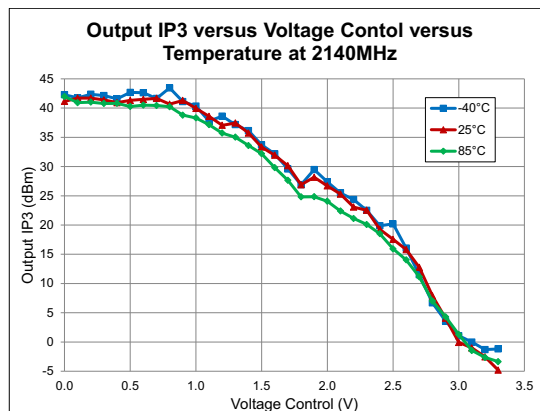
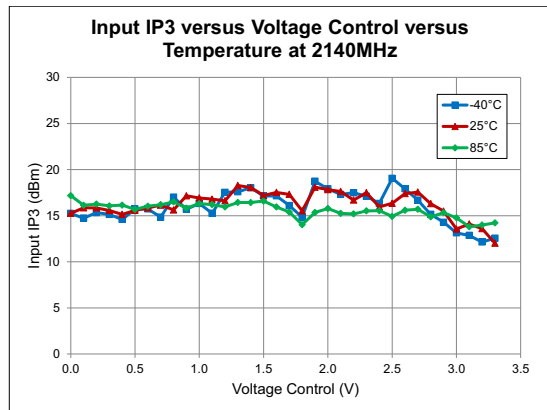
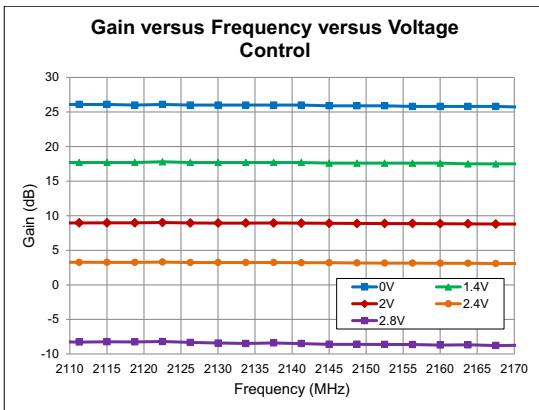
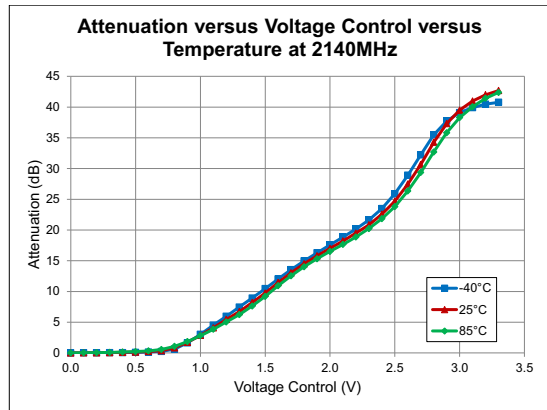
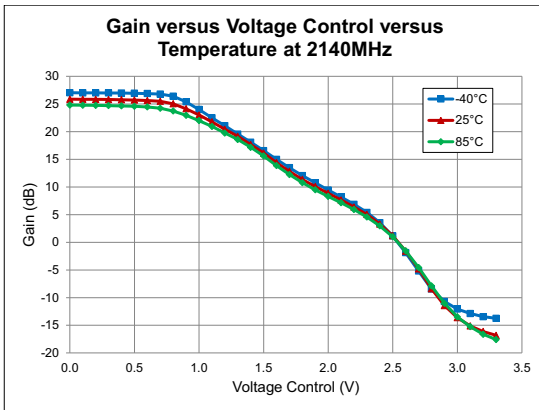

Typical Performance: 2110MHz to 2170MHz Application Circuit

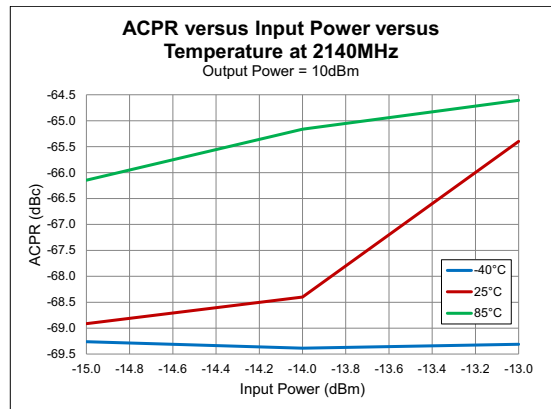
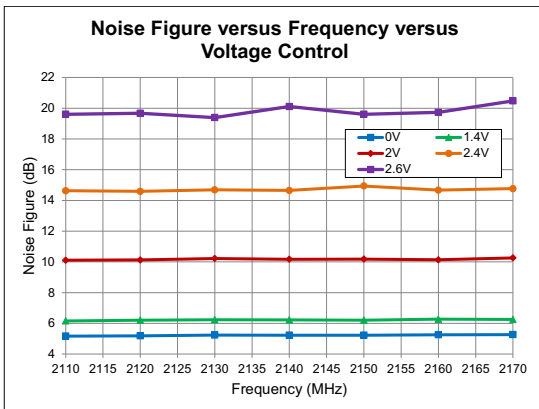
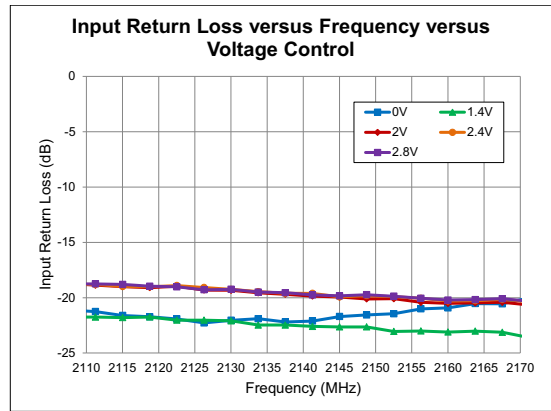
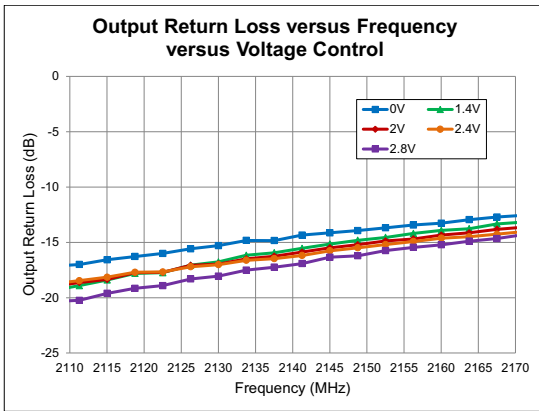
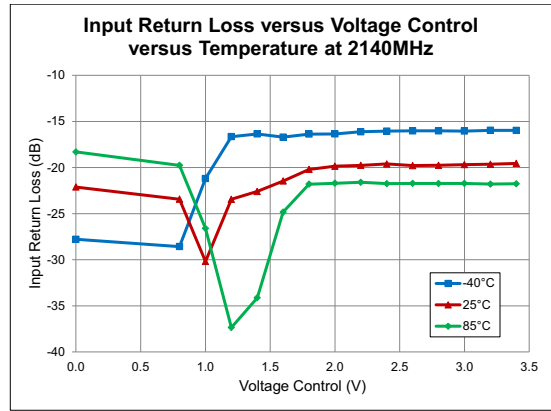
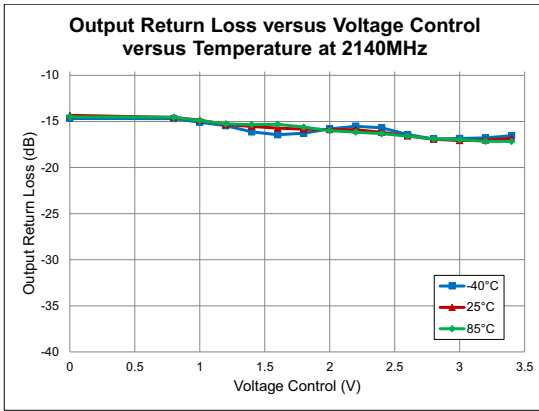

Typical Performance: 2620MHz to 2690MHz Application Circuit

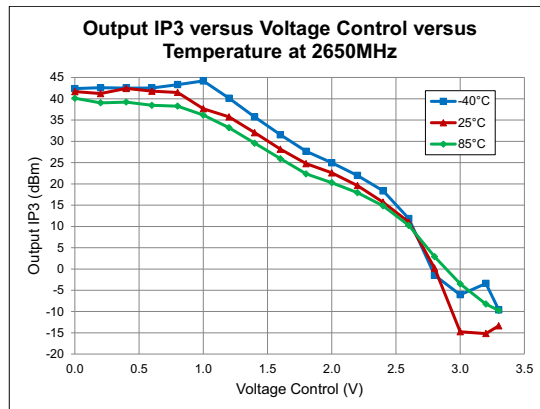
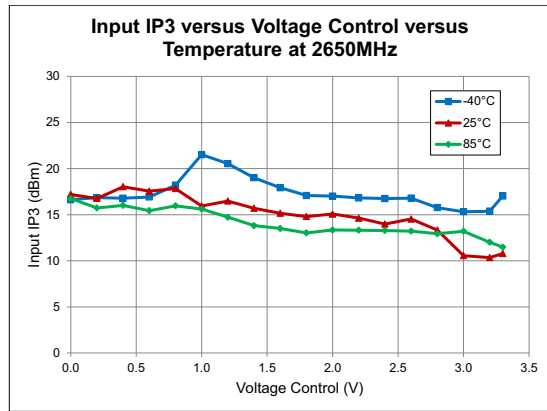
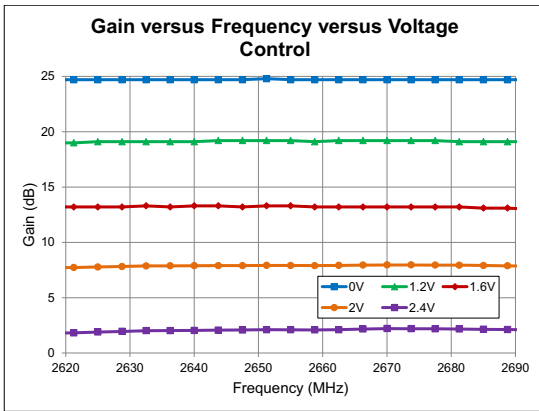
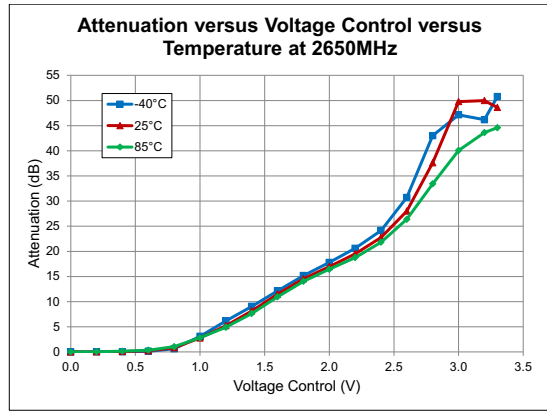
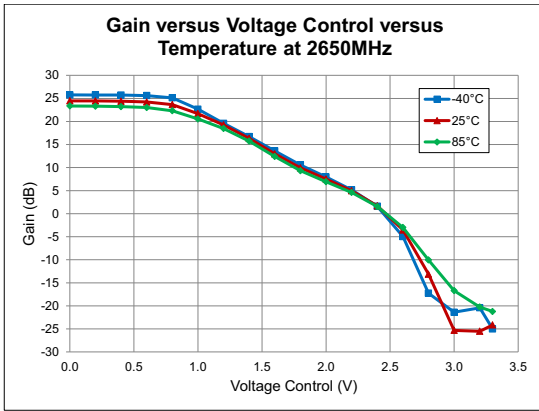

Typical Performance: 2620MHz to 2690MHz Application Circuit

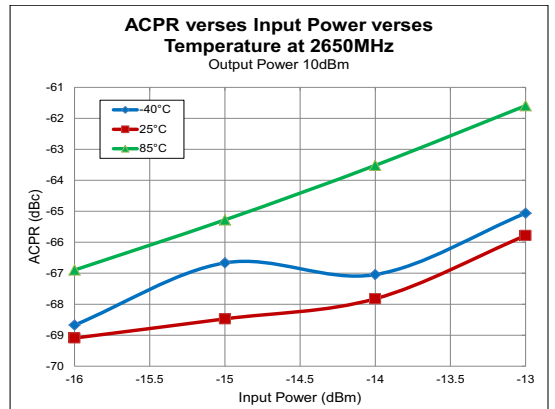
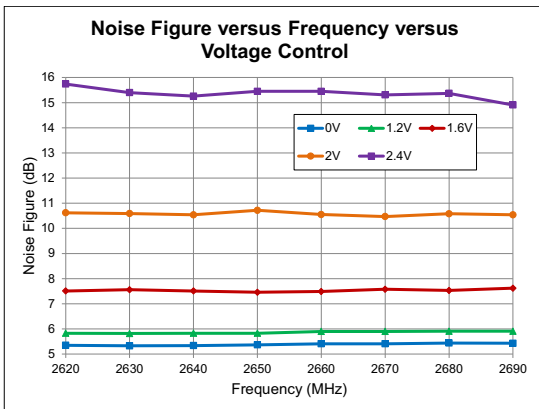
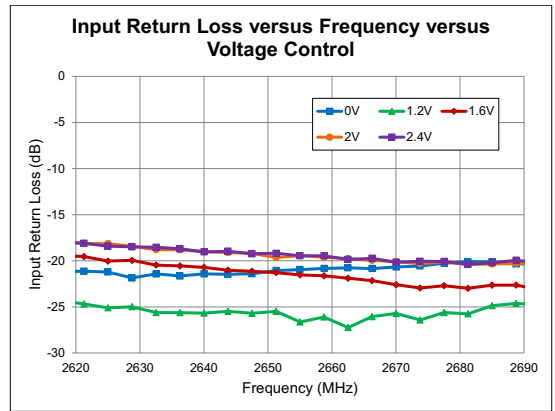
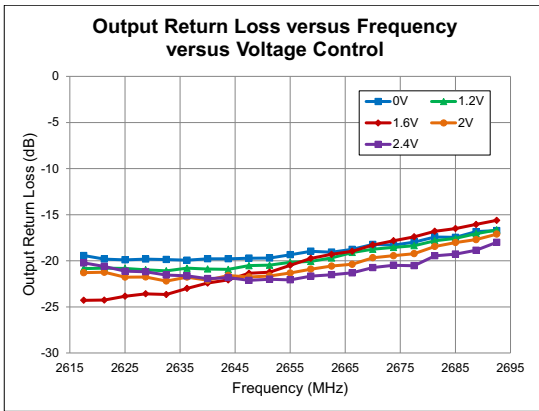
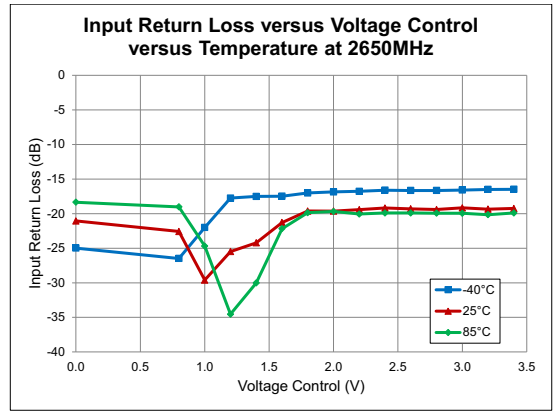
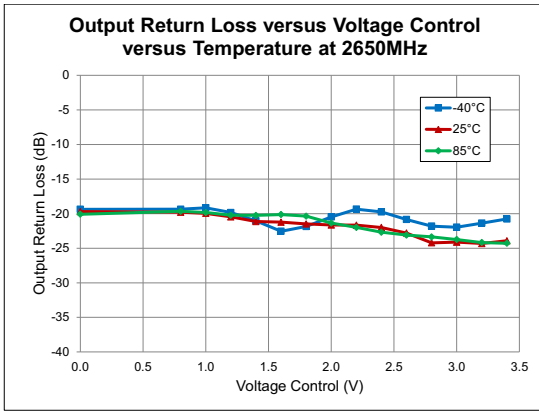

Evaluation Board Schematic 728MHz to 746MHz Application Circuit

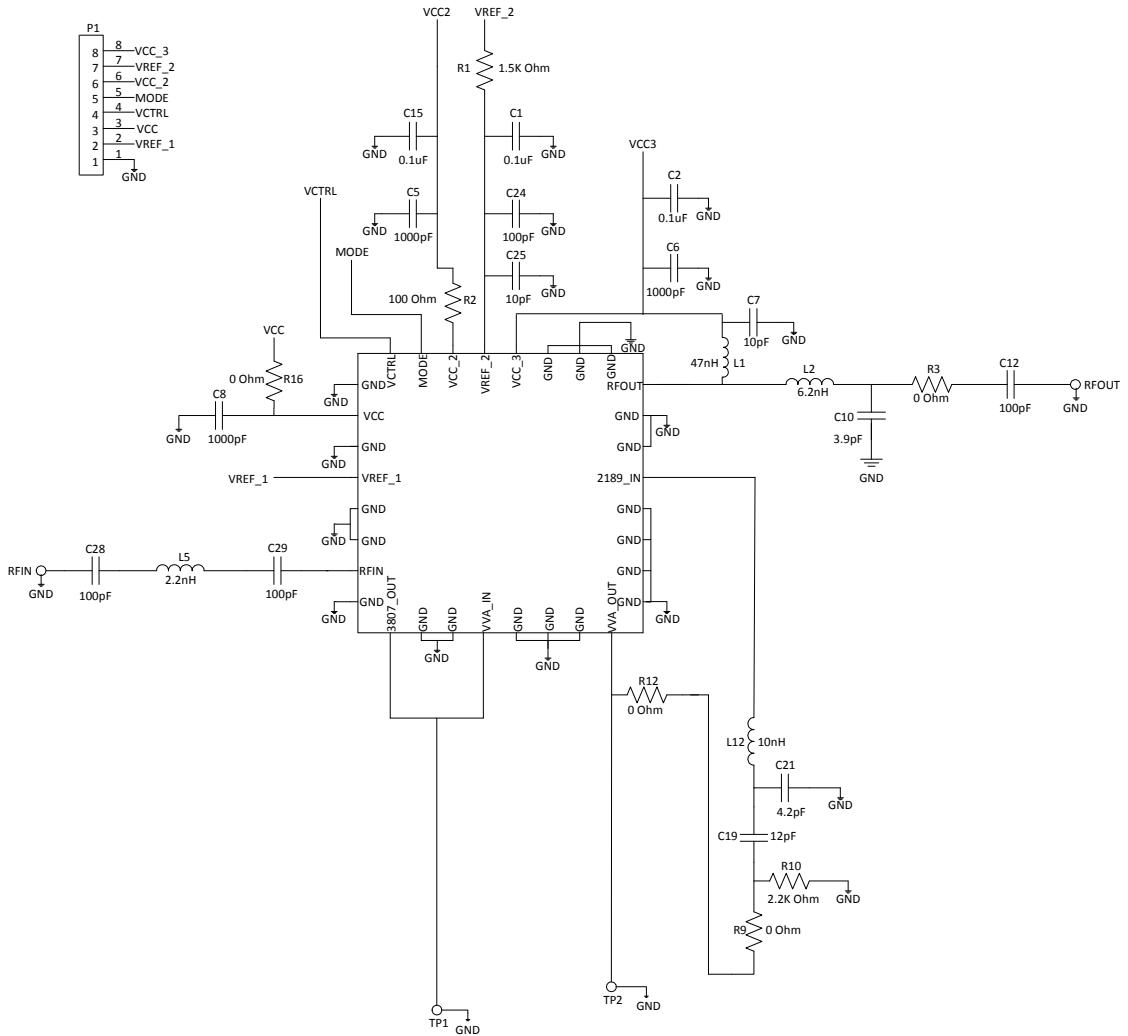

Evaluation Board Bill of Materials (BOM)

728MHz to 746MHz Application Circuit

Description	Reference Designator	Manufacturer	Manufacturer's P/N
VA0016410(A)		DDI	VA0016410(A)
CAP, 0.1uF, 10%, 16V, X7R, 0402	C1-C2, C15	Murata Electronics	GRM155R71C104KA88D
CAP, 100pF, 5%, 50V, COG, 0402	C24	Murata Electronics	GRM1555C1H101JA01D
CAP, 1000pF, 10%, 50V, X7R, 0402	C5-C6, C8	Murata Electronics	GRM155R71H102KA01D
CAP, 10pF, 5%, 50V, COG, 0402	C7, C25	Murata Electronics	GRM1555C1H100JZ01E
CAP, 100pF, 5%, 25V, COG, 0201	C12, C28-C29	Murata Electronics	GRM0335C1E101JD01D
CAP, 3.9pF, +/-0.25pF, 25V, COG, 0201	C10	Murata Electronics	GRM0335C1E3R9CD01E
CAP, 12pF, 1%, 25V, COG, 0201	C19	Murata Electronics	GRM0335C1E120FD01E
CAP, 4.2pF, +/-0.05pF, 25V, COG, 0201	C21	Murata Electronics	GRM0335C1E4R2WD01
IND, 47nH, 5%, M/L, 0402	L1	Murata Electronics	LQG15HN47NJ02D
IND, 2.2nH, +/-0.1nH, T/F, HI-Q, 0201	L5	Murata Electronics	LQP03TN2N2B02D
IND, 10nH, 3%, T/F, HI-Q, 0201	L12	Murata Electronics	LQP03TN10NH02D
IND, 6.2nH, 3%, T/F, HI-Q, 0201	L2	Murata Electronics	LQP03TN6N2H02D
RES, 1.5K, 5%, 1/20W, 0201	R1	Kamaya, Inc	RMC1/20-152JPA15
RES, 100Ω, 5%, 1/20W, 0201	R2	Kamaya, Inc	RMC1/20-101JPA15
RES, 0Ω, 0201	R3, R9, R12	Kamaya, Inc	RMC1/20JPPA15
RES, 2.2K, 5%, 1/20W, 0201	R10	Kamaya, Inc	RMC1/20-222JPA15
RES, 0Ω, 0402	R16	Kamaya, Inc	RMC1/16SJPTH
CONN, SMA, END LNCH, UNIV, HYB MNT, FLT	J1-J4	HEILIND ELECTRONICS	PER MAT-21-1038
CONN, HDR, ST, PLRZD, 8-PIN	P1	ITW Pancon	MPSS100-8-C
DNP	C3-C4, C9, C11, C13-C14, C16-C18, C20, C22-C23, C26-C27, C30-C32, R4-R8, R11, R13-R15, L7, L9, L11, L13		
RFVA0016 Module	U1	RFMD	RFVA0016

Evaluation Board Schematic 2110MHz to 2170MHz Application Circuit

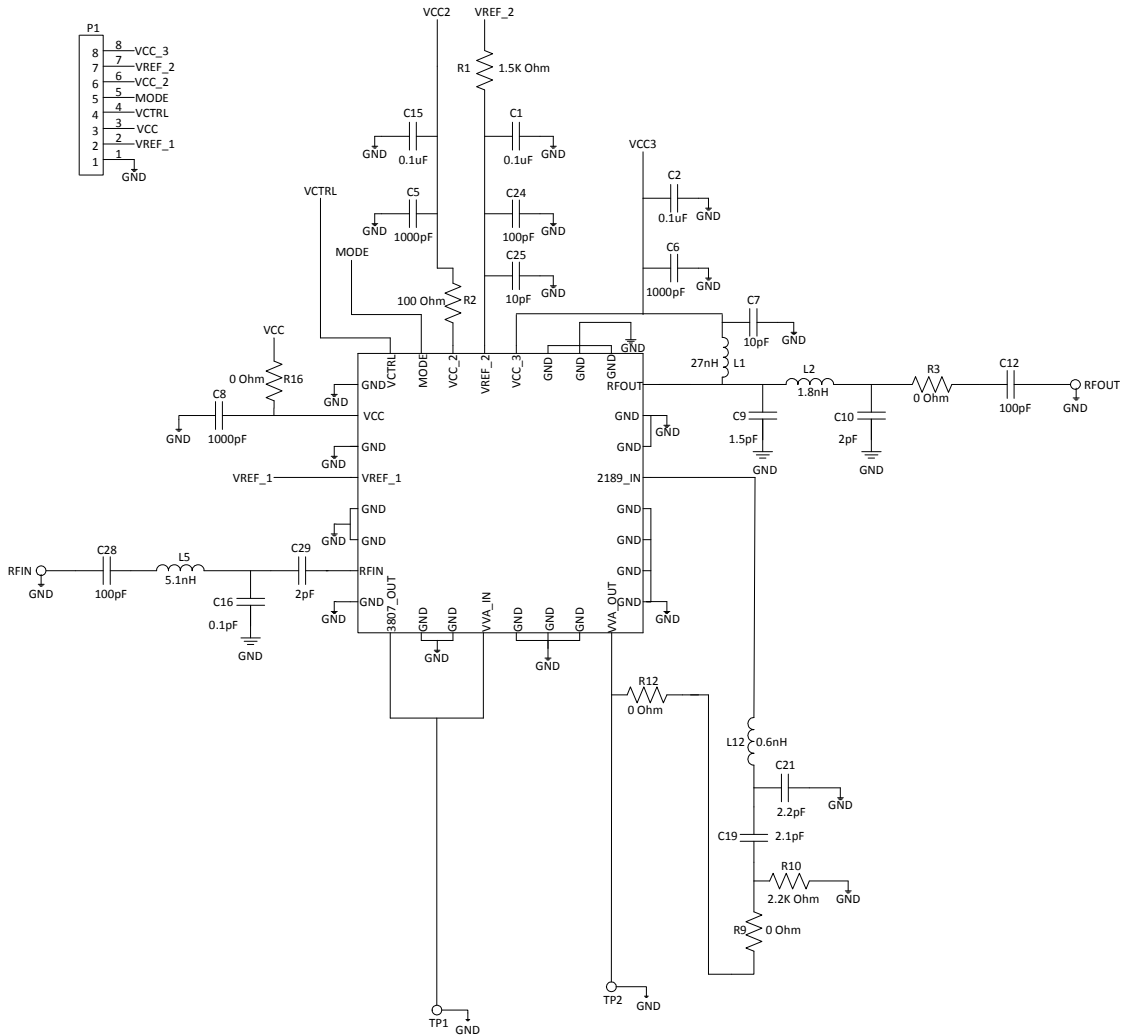

Evaluation Board Bill of Materials (BOM)

2110MHz to 2170MHz Application Circuit

Description	Reference Designator	Manufacturer	Manufacturer's P/N
VA0016410(A)		DDI	VA0016410(A)
CAP, 0.1uF, 10%, 16V, X7R, 0402	C1-C2, C15	Murata Electronics	GRM155R71C104KA88D
CAP, 100pF, 5%, 50V, COG, 0402	C24	Murata Electronics	GRM1555C1H101JA01D
CAP, 1000pF, 10%, 50V, X7R, 0402	C5-C6, C8	Murata Electronics	GRM155R71H102KA01D
CAP, 10pF, 5%, 50V, COG, 0402	C7, C25	Murata Electronics	GRM1555C1H100JZ01E
CAP, 100pF, 5%, 25V, COG, 0201	C12, C28	Murata Electronics	GRM0335C1E101JD01D
CAP, 0.1pF, +/-0.05pF, 25V, COG, 0201	C16	Murata Electronics	GRM0335C1ER10WZ01D
CAP, 2pF, +/-0.1pF, 25V, COG, 0201	C29, C10	Murata Electronics	GRM0335C1E2R0BD01D
CAP, 1.5pF, +/-0.1pF, 25V, COG, 0201	C9	Murata Electronics	GRM0335C1E1R5BD01E
CAP, 2.1pF, +/-0.1pF, 25V, COG, 0201	C19	Murata Electronics	GRM0335C1E2R1BD01E
CAP, 2.2pF, +/-0.1pF, 25V, COG, 0201	C21	Murata Electronics	GRM0335C1E2R2BD01D
IND, 27nH, 5%, M/L, 0402	L1	Murata Electronics	LQG15HN27NJ02D
IND, 5.1nH, 3%, T/F, HI-Q, 0201	L5	Murata Electronics	LQP03TN5N1H02D
IND, 0.6nH, +/-0.1nH, T/F, HI-Q, 0201	L12	Murata Electronics	LQP03TN0N6B02D
IND, 1.8nH, +/-0.1nH, T/F, HI-Q, 0201	L2	Murata Electronics	LQP03TN1N8B02D
RES, 1.5K, 5%, 1/20W, 0201	R1	Kamaya, Inc	RMC1/20-152JPA15
RES, 100Ω, 5%, 1/20W, 0201	R2	Kamaya, Inc	RMC1/20-101JPA15
RES, 0Ω, 0201	R3, R9, R12	Kamaya, Inc	RMC1/20JPPA15
RES, 2.2K, 5%, 1/20W, 0201	R10	Kamaya, Inc	RMC1/20-222JPA15
RES, 0Ω, 0402	R16	Kamaya, Inc	RMC1/16SJPTH
CONN, SMA, END LNCH, UNIV, HYB MNT, FLT	J1-J4	HEILIND ELECTRONICS	PER MAT-21-1038
CONN, HDR, ST, PLRZD, 8-PIN	P1	ITW Pancon	MPSS100-8-C
DNP	C3-C4, C11, C13-C14, C17-C18, C20, C22-C23, C26-C27, C30-C32, R4-R8, R11, R13-R15, L7, L9, L11, L13		
RFVA0016 Module	U1	RFMD	RFVA0016

Evaluation Board Schematic

2620MHz to 2690MHz Application Circuit

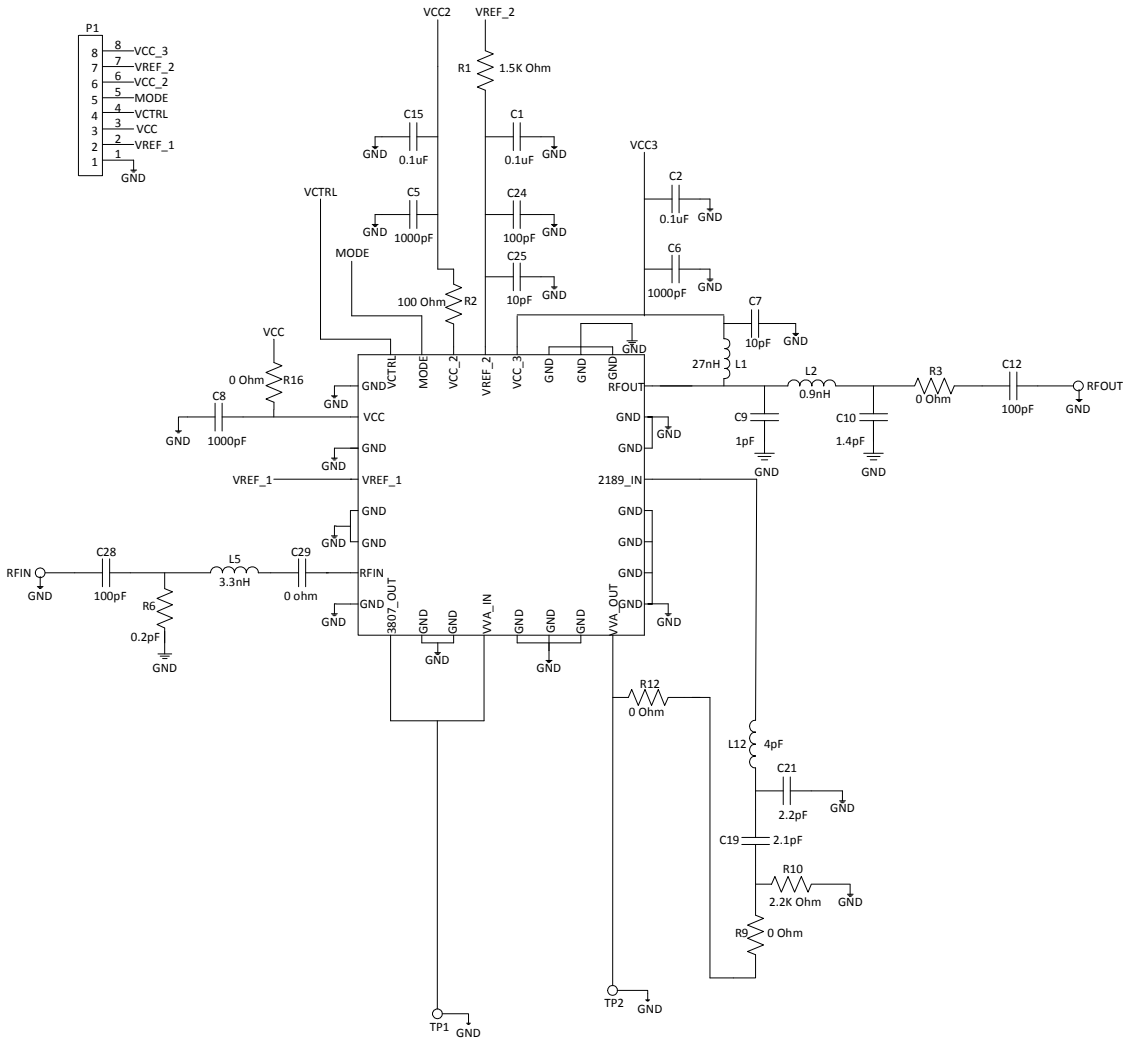

Evaluation Board Bill of Materials (BOM)

2620MHz to 2690MHz Application Circuit

Description	Reference Designator	Manufacturer	Manufacturer's P/N
VA0016410(A)		DDI	VA0016410(A)
CAP, 0.1uF, 10%, 16V, X7R, 0402	C1-C2, C15	Murata Electronics	GRM155R71C104KA88D
CAP, 100pF, 5%, 50V, COG, 0402	C24	Murata Electronics	GRM1555C1H101JA01D
CAP, 1000pF, 10%, 50V, X7R, 0402	C5-C6, C8	Murata Electronics	GRM155R71H102KA01D
CAP, 10pF, 5%, 50V, COG, 0402	C7, C25	Murata Electronics	GRM1555C1H100JZ01E
CAP, 100pF, 5%, 25V, COG, 0201	C12, C28	Murata Electronics	GRM0335C1E101JD01D
CAP, 1.4pF, +/-0.05pF, 25V, COG, 0201	C10	Murata Electronics	GRM0335C1E1R4WD01D
CAP, 1pF, +/-0.1pF, 25V, COG, 0201	C9	Murata Electronics	GRM0335C1E1ROBD01E
CAP, 2.1pF, +/-0.1pF, 25V, COG, 0201	C19	Murata Electronics	GRM0335C1E2R1BD01E
CAP, 2.2pF, +/-0.1pF, 25V, COG, 0201	C21	Murata Electronics	GRM0335C1E2R2BD01D
IND, 27nH, 5%, M/L, 0402	L1	Murata Electronics	LQG15HN27NJ02D
IND, 0.9nH, +/-0.1nH, T/F, HI-Q, 0201	L2	Murata Electronics	LQP03TN0N9B02D
IND, 3.3nH, +/-0.1nH, T/F, HI-Q, 0201	L5	Murata Electronics	LQP03TN3N3B02D
CAP, 4.0pF, +/-0.05pF, 25V, COG, 0201	L12	Murata Electronics	GRM0335C1E4ROWD01
RES, 1.5K, 5%, 1/20W, 0201	R1	Kamaya, Inc	RMC1/20-152JPA15
RES, 100Ω, 5%, 1/20W, 0201	R2	Kamaya, Inc	RMC1/20-101JPA15
CAP, 0.2pF, +/-0.05pF, 25V, COG, 0201	R6	Murata Electronics	GRM0335C1ER20WZ01D
RES, 0Ω, 0201	R3, R9, R12, C29	Kamaya, Inc	RMC1/20JPPA15
RES, 2.2K, 5%, 1/20W, 0201	R10	Kamaya, Inc	RMC1/20-222JPA15
RES, 0Ω, 0402	R16	Kamaya, Inc	RMC1/16SJPTH
CONN, SMA, END LNCH, UNIV, HYB MNT, FLT	J1-J4	HEILIND ELECTRONICS	PER MAT-21-1038
CONN, HDR, ST, PLRZD, 8-PIN	P1	ITW Pancon	MPSS100-8-C
DNP	C3-C4, C11, C13-C14, C16-C18, C20, C22-C23, C26-C27, C30- C32, R4- R5, R7-R8, R11, R13-R15, L7, L9, L11, L13		
RFVA0016 Module	U1	RFMD	RFVA0016

Mode Pin Truth Table

MODE	Min Attenuation	Max Attenuation
Low or 0V	0V	3.3V
High or 5V	5V	0V

Pin Names and Descriptions

Pin	Name	Description
1	GND	Low inductive path to ground.
2	VCC1	V _{CC} Supply.
3	GND	Low inductive path to ground.
4	NC	No Connect.
5	GND	Low inductive path to ground.
6	GND	Low inductive path to ground.
7	RFIN	RF Input (externally matched to 50Ω)
8	GND	Low inductive path to ground.
9	NC	No Connect.
10	GND	Low inductive path to ground.
11	GND	Low inductive path to ground.
12	NC	No Connect.
13	GND	Low inductive path to ground.
14	GND	Low inductive path to ground.
15	GND	Low inductive path to ground.
16	IS2_OUT	Interstage RF Output to allow matching to last stage amplifier.
17	GND	Low inductive path to ground.
18	GND	Low inductive path to ground.
19	GND	Low inductive path to ground.
20	GND	Low inductive path to ground.
21	IS3_IN	Interstage RF IN to allow matching to last stage amplifier.
22	GND	Low inductive path to ground.
23	GND	Low inductive path to ground.
24	RFOUT	RF Output (externally matched to 50Ω)
25	GND	Low inductive path to ground.
26	GND	Low inductive path to ground.
27	GND	Low inductive path to ground.
28	VCC3	Supply Voltage.
29	VREF2	Reference Voltage to set current of last stage device.
30	VCC2	Supply Voltage.
31	MODE	Mode select pin to select positive or negative slope of the V _{CTRL} voltage, see Mode Pin Truth table.
32	VCTRL	Voltage Variable Amplifier Control Voltage.

IO Pattern

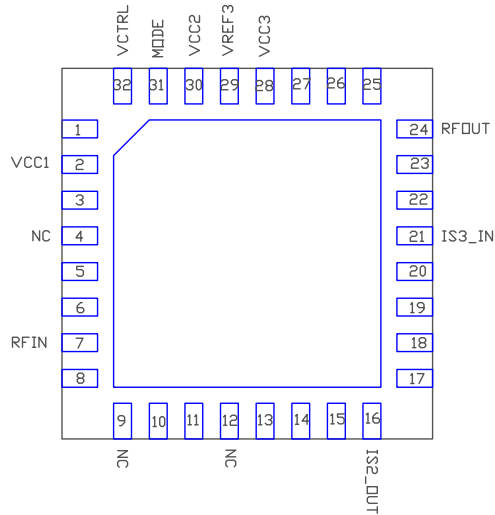

Note: All other pins are grounded.

Package Outline Drawing

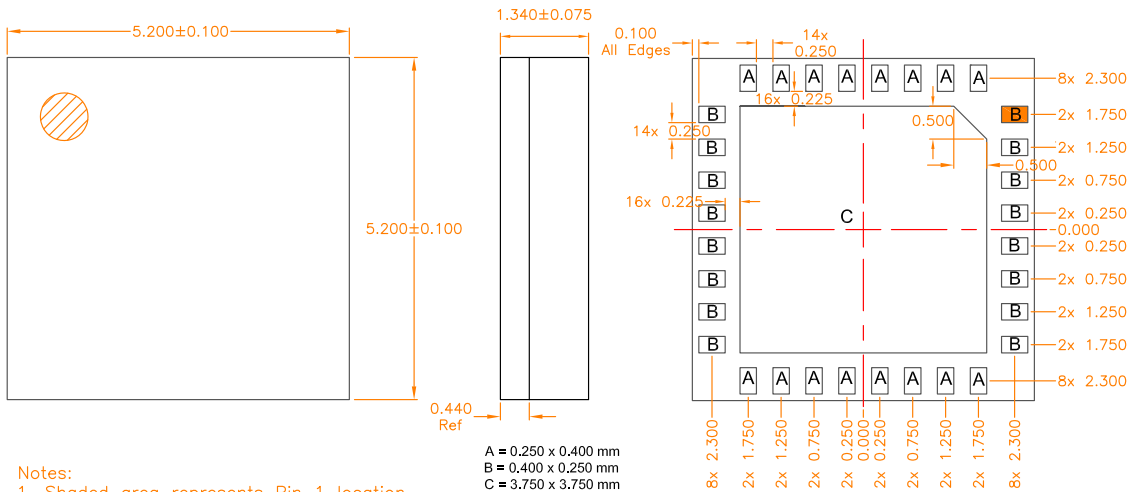

Evaluation Board Assembly Drawing

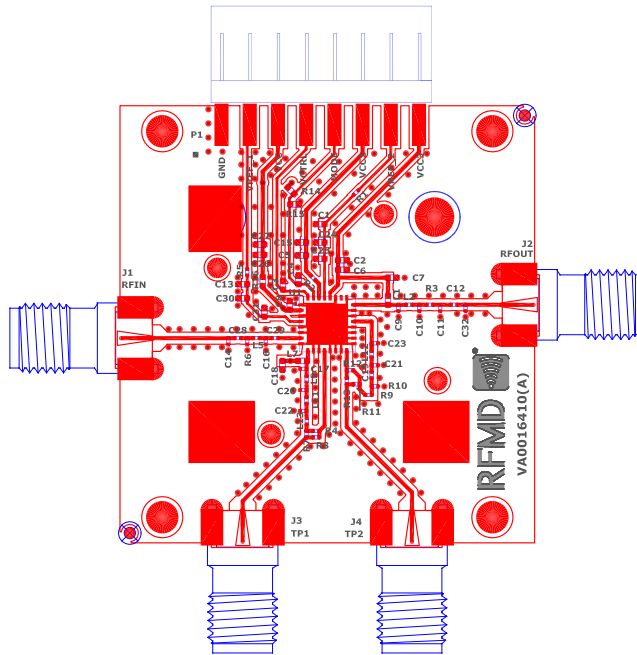

Note: TP1 and TP2 are test ports for interstage tuning.

Branding Diagram

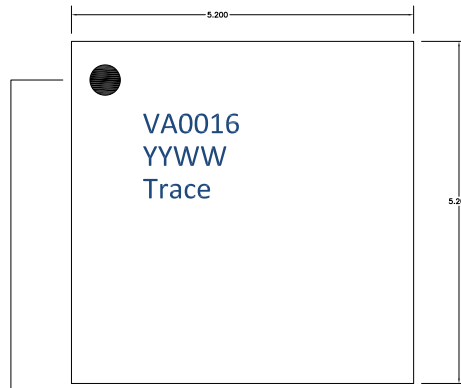

Pin 1 Indicator
YY = Year
WW = Week