



Features

- Low Noise and High Intercept Point
- Adjustable Bias Current
- Power Down Control
- Low Insertion Loss Bypass Feature
- 1.8V to 4V Operation (See “Bias Note” on Page 3)
- 0.9GHz to 4.0GHz Operation

Applications

- WiFi LNA with Bypass Feature
- WiMAX LNA with Bypass Feature
- CDMA PCS LNA with Bypass Feature
- Suitable for 1x2 or 2x1 MIMO Applications
- Commercial and Consumer Systems

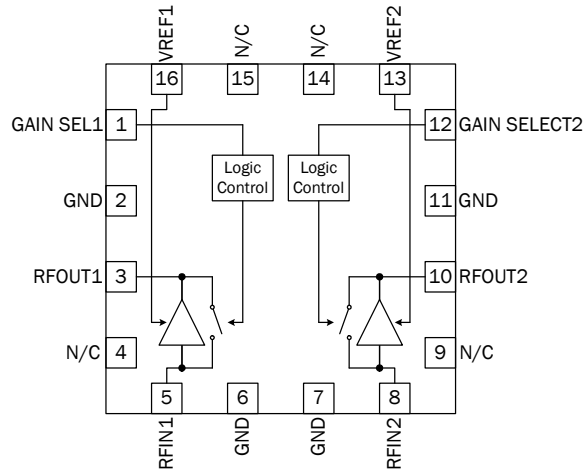

Functional Block Diagram

Product Description

The RF3857 is a dual channel switchable low noise amplifier with a very high dynamic range designed for digital cellular, WiMAX, and WiFi applications. The device functions as an outstanding front end low noise amplifier. The bias current may be set externally. The RF3857 combines two receive paths, which is ideal in an application that requires two receive paths, such as 1x2 and 2x2 MIMO for both WiFi and WiMax applications. The IC is featured in a standard QFN, 16-pin, 3mmx3mm plastic package.

Optimum Technology Matching® Applied

- | | | | |
|--|--------------------------------------|-------------------------------------|-----------------------------------|
| <input checked="" type="checkbox"/> GaAs HBT | <input type="checkbox"/> SiGe BiCMOS | <input type="checkbox"/> GaAs pHEMT | <input type="checkbox"/> GaN HEMT |
| <input type="checkbox"/> GaAs MESFET | <input type="checkbox"/> Si BiCMOS | <input type="checkbox"/> Si CMOS | <input type="checkbox"/> RF MEMS |
| <input type="checkbox"/> InGaP HBT | <input type="checkbox"/> SiGe HBT | <input type="checkbox"/> Si BJT | <input type="checkbox"/> LDMOS |

RF MICRO DEVICES®, RFMD®, Optimum Technology Matching®, Enabling Wireless Connectivity™, PowerStar®, POLARIS™ TOTAL RADIO™ and UltimateBlue™ are trademarks of RFMD, LLC. BLUETOOTH is a trademark owned by Bluetooth SIG, Inc., U.S.A. and licensed for use by RFMD. All other trade names, trademarks and registered trademarks are the property of their respective owners. ©2006, RF Micro Devices, Inc.

Absolute Maximum Ratings

Parameter	Rating	Unit
Supply Voltage	-0.5 to +6.0	V _{DC}
Input RF Level	+5 (see note)	dBm
Current Drain, I _{CC} per Channel	32	mA
Operating Ambient Temperature	-40 to +85	°C
Storage Temperature	-40 to +150	°C

NOTE: Exceeding any one or a combination of the above maximum rating limits may cause permanent damage. Input RF transients to +15dBm will not harm the device. For sustained operation at inputs $\geq +5$ dBm, a small dropping resistor is recommended in series with the V_{CC} in order to limit the current due to self-biasing to <32mA per channel.



Caution! ESD sensitive device.

Exceeding any one or a combination of the Absolute Maximum Rating conditions may cause permanent damage to the device. Extended application of Absolute Maximum Rating conditions to the device may reduce device reliability. Specified typical performance or functional operation of the device under Absolute Maximum Rating conditions is not implied.

RoHS status based on EUDirective2002/95/EC (at time of this document revision).

The information in this publication is believed to be accurate and reliable. However, no responsibility is assumed by RF Micro Devices, Inc. ("RFMD") for its use, nor for any infringement of patents, or other rights of third parties, resulting from its use. No license is granted by implication or otherwise under any patent or patent rights of RFMD. RFMD reserves the right to change component circuitry, recommended application circuitry and specifications at any time without prior notice.

Parameter	Specification			Unit	Condition
	Min.	Typ.	Max.		
Typical Operating Conditions					Temp = 25 °C, V _{CC} = 3.3V, V _{REF} = 3.3V, Frequency = 2450MHz for WiBro/WiFi Tune and 3500MHz for WiMax Tune, Gain Select = Low or High depending on the test unless otherwise noted in the condition column)
Frequency Range	900		4000	MHz	
WiBRO/WiFi Low Noise Amplifier					
Frequency	2300	2450	2900	MHz	
HIGH GAIN MODE					Gain Select < 0.8V, V _{REF} = 3.3V, T = +25 °C
Gain	12.0	14.0	17.0	dB	RFIN1 to RFOUT1 or RFIN2 to RFOUT2 receive paths over full temp range, frequency, and process.
Noise Figure	1.0	1.3	1.55	dB	Over full temp range, frequency, and process.
Input IP3	+7.0	+9.0		dBm	IIP3 will improve if ICC is raised above 7 mA.
Output VSWR		1.7:1	2:1		
Total Current Drain (per channel)		8.5		mA	Total current includes I _{CC} + I _{REF}
Channel Isolation		-40		dBc	Difference between the P _{OUT} at RFOUT1 and RFOUT2 when signal is applied at RFIN1 or RFIN2
BYPASS MODE					Gain Select > 1.8V, V _{REF} = 0V, V _{CC} = 3.3V
Gain	-3.0	-2.5	-2.0	dB	Both RX paths, over full temp range and process. Note: Bypass mode insertion loss will degrade gradually as V _{CC} goes below 2.7V.
Input IP3	+19.5	+21.0	+23.0	dBm	For each RX path, over full temp range, and process.
Output VSWR		1.6:1			
Total Current Drain		2.0	3.0	mA	Total current includes I _{CC} + I _{REF}
WiMAX Low Noise Amplifier					
HIGH GAIN MODE					Gain Select < 0.8V, V _{REF} = 3.3V, V _{CC} = 3.3V
Frequency	3100	3500		MHz	
Gain	10	12	14.5	dB	RFIN1 to RFOUT1 or RFIN2 to RFOUT2 receive paths over full temp range, frequency, and process.

Parameter	Specification			Unit	Condition
	Min.	Typ.	Max.		
WiMAX Low Noise Amplifier, cont.					
Noise Figure	1.2	1.7	2.0	dB	Over full temp range, frequency range, and process.
IIP3		9		dBm	
Total Current Drain (per channel)		8.5	10	mA	Total current drain includes $I_{CC} + I_{REF}$. $V_{CC}=3.3V$, $V_{REF}=3.3V$, Gain select < 1.8V.
BYPASS MODE					Gain Select > 1.8V, $V_{REF}=0V$
Gain		-3		dB	Note: Bypass mode insertion loss will degrade gradually as V_{CC} goes below 2.7V.
Input IP3		20		dBm	
Total Current Drain (per channel)		2		mA	Total current drain includes $I_{CC} + I_{REF}$
Power Supply					
Voltage (V_{CC})	1.8	3.0	5.0	V	See bias note
V_{SELECT} Low			0.8	V	High Gain mode. Gain Select < 0.8V, $V_{REF}=3.3V$
V_{SELECT} High	1.8			V	Low Gain mode. Gain Select > 1.8V, $V_{REF}=0V$
Power Down per RX Path	0		10	μA	Gain Select < 0.8V, $V_{REF}=0V$, $V_{CC}=3.3V$ (Over full temp range, frequency, and beta)
VREF1 or VREF 2 Turn On/Off		100	<150	nSec	For faster turn on and off time C1 and C2 should be changed from 22 nF to a value between 10 pF to 100 pF
Gain Select 1 or 2 Turn On/Off		100	<150	nSec	For faster turn on and off time C1 and C2 should be changed from 22 nF to a value between 3.0 pF to 100 pF

Bias note: Due to the presence of ESD protection circuitry on the RF3857, the maximum allowable collector bias voltage (pin 4) is 4.0V. Higher supply voltages such as 5V are permissible if a series resistor is used to drop V_{CC} to $\leq 4.0V$ for a given I_{CC} .

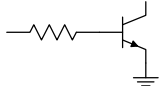
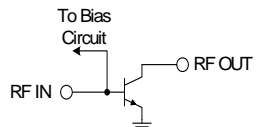
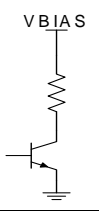
Pin	Function	Description	Interface Schematic
1	GAIN SEL1	This pin selects high gain and bypass modes for Amplifier 1. Gain Sel1 \leq 0.8V, Amp1 high gain. Gain Sel1 \geq 1.8V, Amp1 bypass.	
2	GND	Amplifier 1 ground connection. For best performance, keep traces physically short and connect immediately to ground plane.	
3	RFOUT1	Amplifier 1 output pin. This pin is an open-collector output. It must be biased to VCC through a choke or matching inductor. This pin is matched to 50Ω with the network shown in the evaluation board schematic.	
4	N/C	No internal connection.	
5	RFIN1	RF input pin for amplifier 1. This part is designed such that 50Ω is the optimal source impedance for best noise figure. Best noise figure is achieved with only a series capacitor on the input.	
6	GND	Isolation ground connection. Can be grounded or not connected.	
7	GND	See pin 7.	
8	RFIN2	RF input pin for amplifier 2. See pin 5.	
9	N/C	No internal connection.	
10	RFOUT2	Amplifier 2 output pin. See pin 3.	
11	GND	Amplifier 2 ground connection. See pin 2.	
12	GAIN SEL2	Selects high gain and bypass modes for Amplifier 2. See pin 1.	
13	VREF2	Bias control for amplifier 2. An external resistor can be used to set the bias current for any V_{REF} voltage.	
14	N/C	No internal connection.	
15	N/C	No internal connection.	
16	VREF1	Bias control for amplifier 1. See pin 13.	

Package Drawing

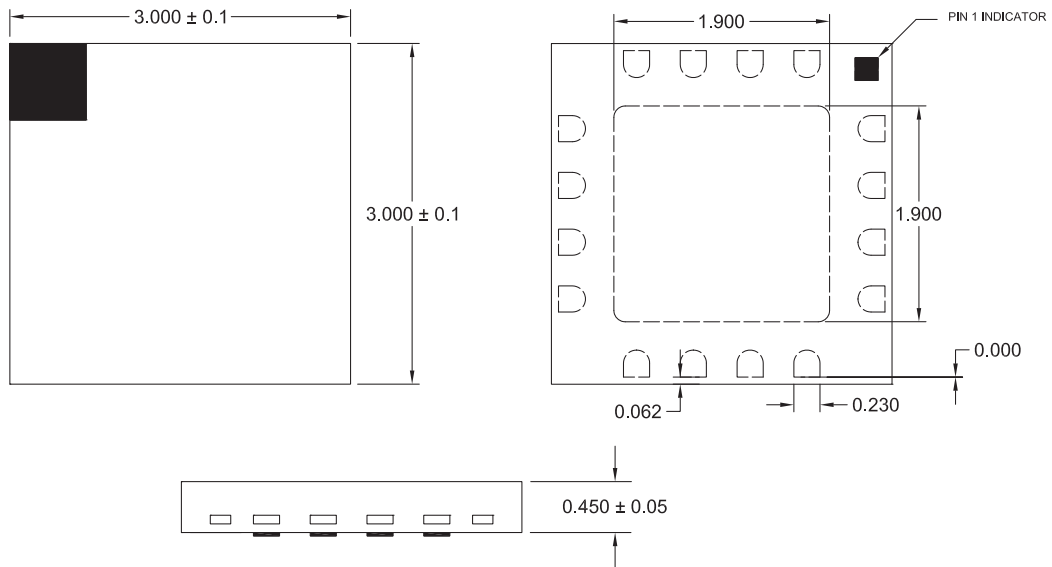

NOTES:
 1 Shaded Area is Pin 1 Indicator

Evaluation Board Schematic
WiMAX (3.1GHz to 3.8GHz)

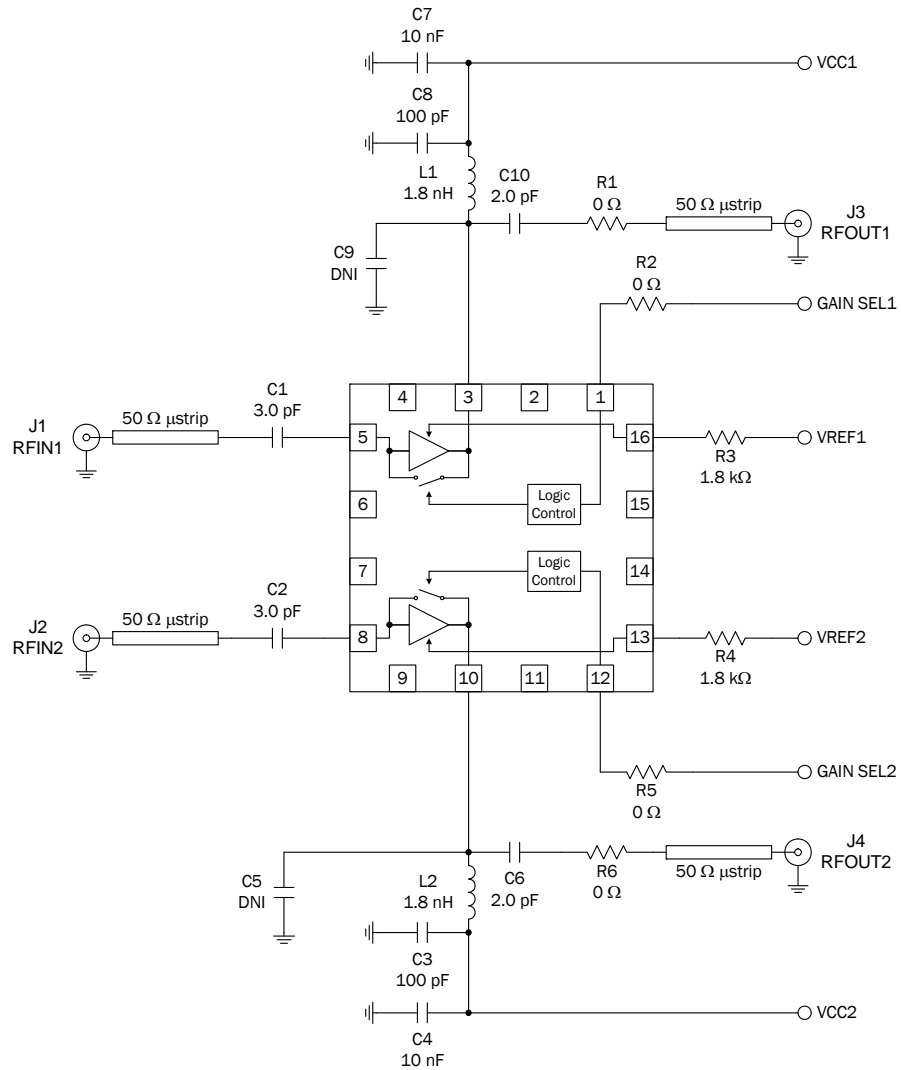

WiBRO/WiFi DATA

GAIN at WiFi Band in High Gain Mode
 $V_{CC}=3.3V$ and $V_{REF}=3.3V$ Over Temp

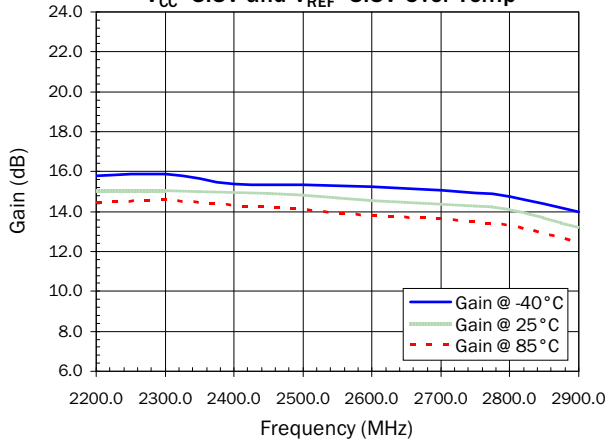

Gain at WiFi Band in Bypass Mode
 $V_{CC}=3.3V$ and $V_{REF}=3.3V$ Over Temp

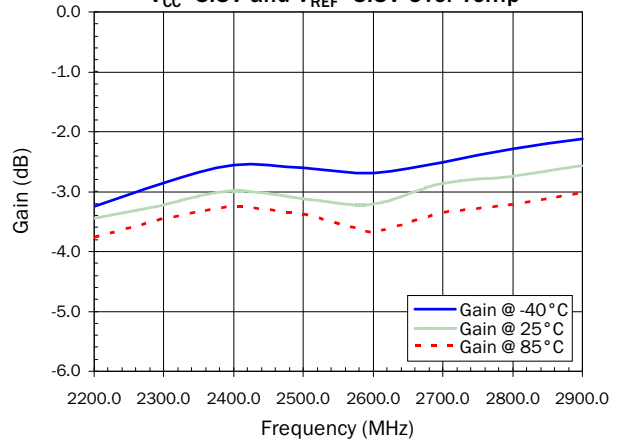

Noise Figure at WiFi Band in High Gain Mode
 $V_{CC}=3.3V$ and $V_{REF}=3.3V$ Over Temp

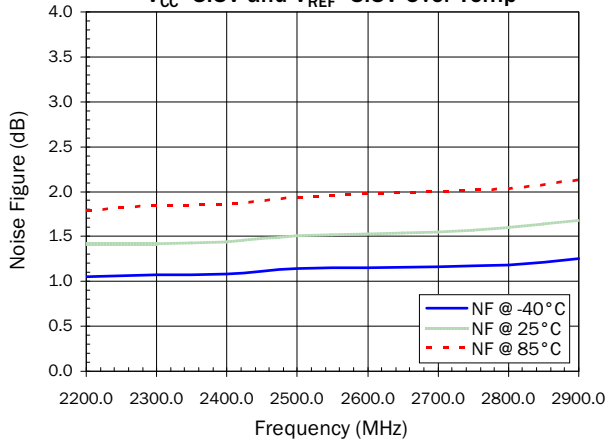

IIP3 at WiFi Band in High Gain Mode
 $V_{CC}=3.3V$ and $V_{REF}=3.3V$ Over Temp

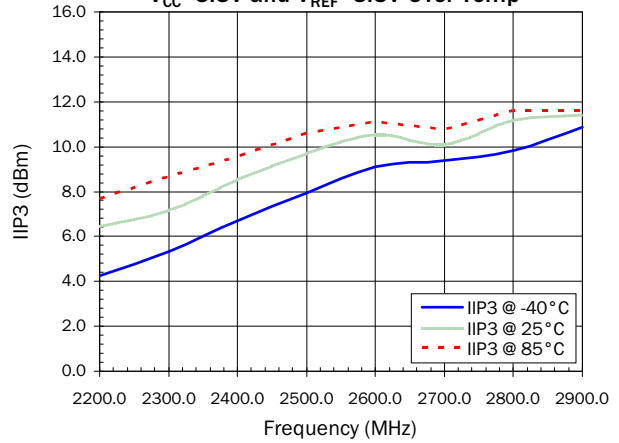

IIP3 at WiFi Band in Bypass Mode
 $V_{CC}=3.3V$ and $V_{REF}=3.3V$ Over Temp

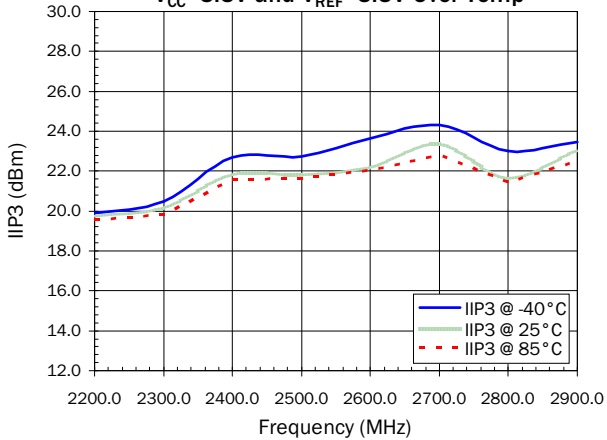

$I_{CC} + I_{REF}$ at WiFi Band in High Gain Mode
 $V_{CC}=3.3V$ and $V_{REF}=3.3V$ Over Temp

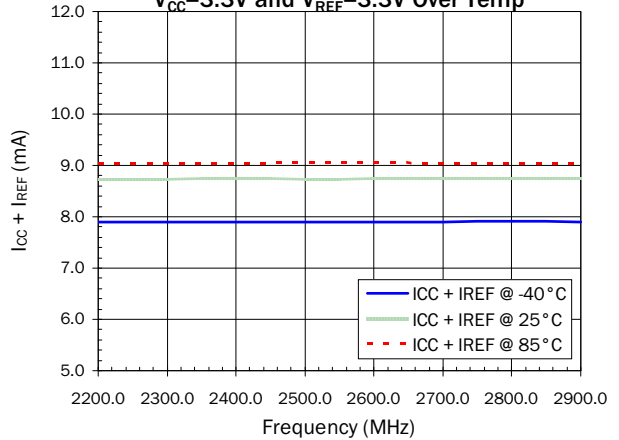

WiMAX DATA

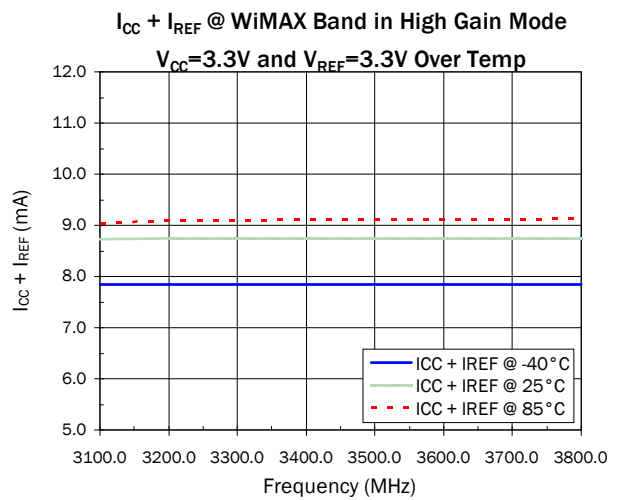
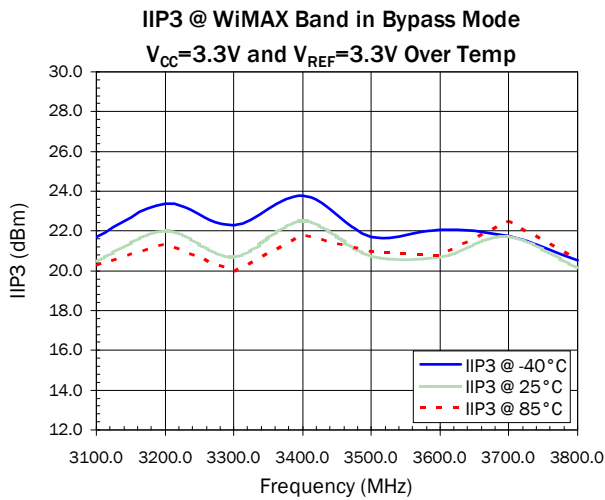
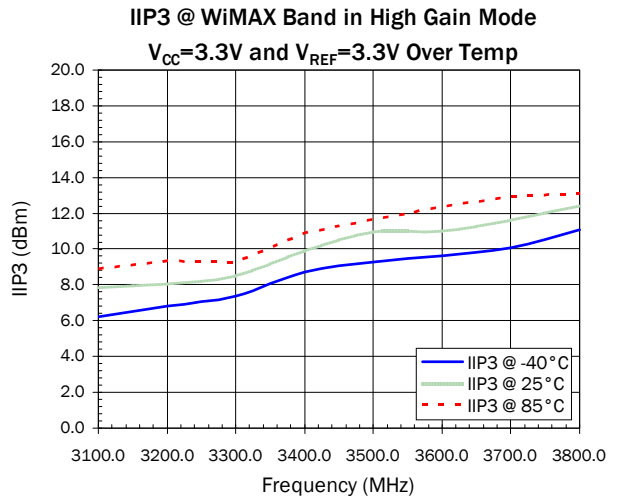
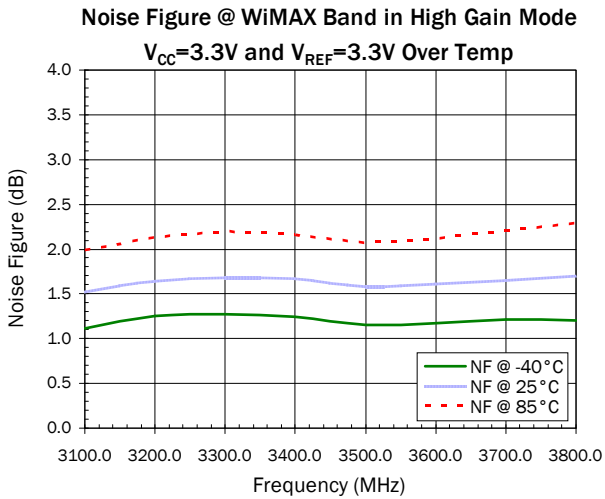
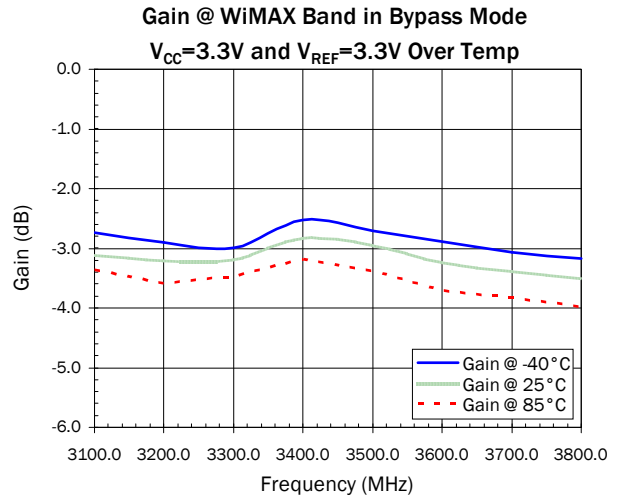
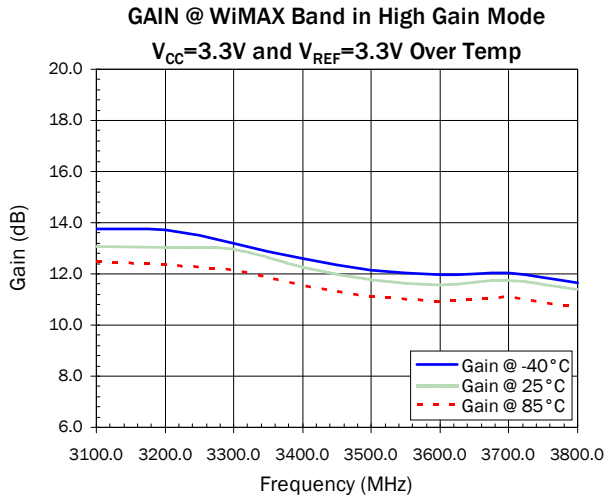

Evaluation Board Layout Board Size 1.0" x 1.5" Board Thickness 0.032", Board Material FR-4

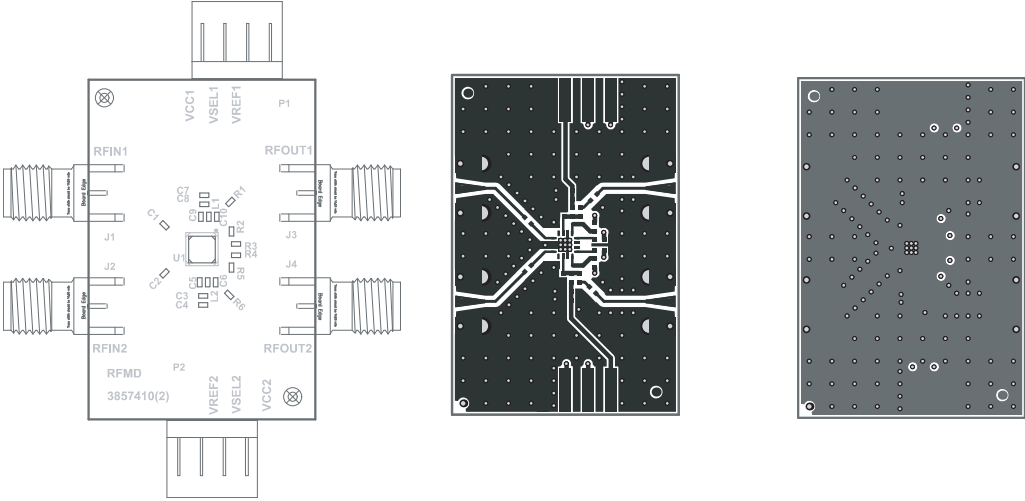

Ordering Information

Ordering Code	Description
RF3857	Standard 25 piece bag
RF3857SR	Standard 100 piece reel
RF3857TR7	Standard 2500 piece reel
RF3857PCK-410	Fully assembled evaluation board tuned for 2.0GHz to 3.0GHz and 5 loose sample pieces
RF3857PCK-411	Fully assembled evaluation board tuned for 3.1GHz to 4.0GHz and 5 loose sample pieces