



Features

- 32dB to 34dB Small Signal Gain
- 2.5% EVM (RMS) at 27dBm, 5.0V
- 2.5% EVM (RMS) at 25.5dBm, 4.2V
- 2.5% EVM (RMS) at 24dBm, 3.3V
- Integrated Power Detector on Die
- Multiple Frequency Ranges
- High Impedance Control

Applications

- IEEE 802.11b/g/n WiFi Systems
- 2.4GHz ISM Band Applications
- Commercial and Consumer Systems
- WiBro 2.3GHz to 2.4GHz Band Applications
- WiFi 2.4GHz to 2.5GHz Band Applications
- WiMAX 2.5GHz to 2.7GHz Band Applications

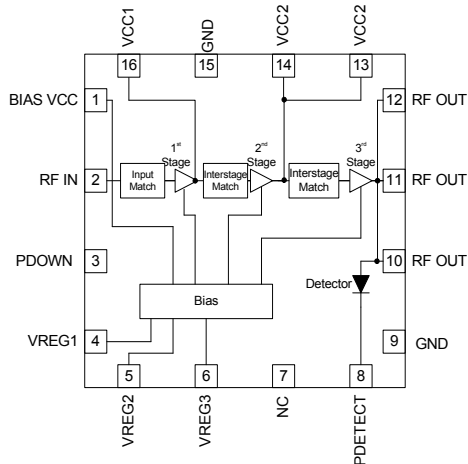

Functional Block Diagram

Product Description

The RF5602 is a linear power amplifier IC designed specifically for medium power applications. The device is manufactured on an advanced InGaP Heterojunction Bipolar Transistor (HBT) process, and has been designed for use as the final RF amplifier in 802.11b/g/n access point transmitters. The device is provided in a 3mm x 3mm x 0.45mm, 16-pin, leadless chip carrier with a backside ground. The RF5602 is designed to maintain linearity over a wide range of supply voltages and power outputs.

Optimum Technology Matching® Applied

- | | | | |
|---|--------------------------------------|-------------------------------------|------------------------------------|
| <input type="checkbox"/> GaAs HBT | <input type="checkbox"/> SiGe BiCMOS | <input type="checkbox"/> GaAs pHEMT | <input type="checkbox"/> GaN HEMT |
| <input type="checkbox"/> GaAs MESFET | <input type="checkbox"/> Si BiCMOS | <input type="checkbox"/> Si CMOS | <input type="checkbox"/> BIFET HBT |
| <input checked="" type="checkbox"/> InGaP HBT | <input type="checkbox"/> SiGe HBT | <input type="checkbox"/> Si BJT | <input type="checkbox"/> LDMOS |

RF MICRO DEVICES®, RFMD®, Optimum Technology Matching®, Enabling Wireless Connectivity™, PowerStar®, POLARIS™ TOTAL RADIO™ and UltimateBlue™ are trademarks of RFMD, LLC. BLUETOOTH is a trademark owned by Bluetooth SIG, Inc., U.S.A. and licensed for use by RFMD. All other trade names, trademarks and registered trademarks are the property of their respective owners. ©2006, RF Micro Devices, Inc.

Absolute Maximum Ratings

Parameter	Rating	Unit
Supply Voltage, RF applied	-0.5 to +5.25	V _{DC}
Supply Voltage, no RF applied	-0.5 to +6.0	V _{DC}
DC Supply Current	800	mA
Input RF Power	+10*	dBm
Operating Ambient Temperature	-40 to +85	°C
Storage Temperature	-40 to +150	°C
Moisture Sensitivity	MSL1	

*Maximum Input Power with a 50Ω load



Caution! ESD sensitive device.

Exceeding any one or a combination of the Absolute Maximum Rating conditions may cause permanent damage to the device. Extended application of Absolute Maximum Rating conditions to the device may reduce device reliability. Specified typical performance or functional operation of the device under Absolute Maximum Rating conditions is not implied.

The information in this publication is believed to be accurate and reliable. However, no responsibility is assumed by RF Micro Devices, Inc. ("RFMD") for its use, nor for any infringement of patents, or other rights of third parties, resulting from its use. No license is granted by implication or otherwise under any patent or patent rights of RFMD. RFMD reserves the right to change component circuitry, recommended application circuitry and specifications at any time without prior notice.



RFMD Green: RoHS compliant per EU Directive 2002/95/EC, halogen free per IEC 61249-2-21, < 1000ppm each of antimony trioxide in polymeric materials and red phosphorus as a flame retardant, and <2% antimony in solder.

Parameter	Specification			Unit	Condition
	Min.	Typ.	Max.		
WiFi IEEE 802.11b/g/n					Nominal Condition T = 25 °C, V _{CC} = 3.3V, 4.2V, and 5V, V _{REG} = 2.9V, Freq = 2450MHz, Duty Cycle 10 to 100% unless otherwise noted
Frequency Range	2400		2500	MHz	
Compliance					IEEE 802.11g/n and IEEE 802.11b
Output Power	26	27		dBm	With a standard IEEE 802.11g waveform (54Mbit/s), V _{CC} = 5.0V
EVM		2.5	3	%	RMS, Mean (at 100% duty cycle over Full V _{REG} and frequency ranges)
IEEE 802.11b P _{OUT}	28	28.5		dBm	
ACP1		-34	-30		using a standard IEEE 802.11b waveform at 1Mbps
ACP2		-54	-50		using a standard IEEE 802.11b waveform at 1Mbps
Output Power	25	25.5		dBm	With a standard IEEE 802.11g waveform (54Mbit/s), V _{CC} = 4.2V
EVM		2.5	3	%	RMS, Mean (at 100% duty cycle over Full V _{REG} and frequency ranges)
IEEE 802.11b P _{OUT}		27		dBm	
ACP1		-34	-30		using a standard IEEE 802.11b waveform at 1Mbps
ACP2		-54	-50		using a standard IEEE 802.11b waveform at 1Mbps
Output Power	23.5	24		dBm	With a standard IEEE 802.11g waveform (54Mbit/s), V _{CC} = 3.3V
EVM		2.5	3.5	%	RMS, Mean (at 100% duty cycle over Full V _{REG} and frequency ranges)
IEEE 802.11b P _{OUT}		25.5		dBm	
ACP1		-34	-30		using a standard IEEE 802.11b waveform at 1Mbps
ACP2		-54	-50		using a standard IEEE 802.11b waveform at 1Mbps

Parameter	Specification			Unit	Condition
	Min.	Typ.	Max.		
WiFi IEEE 802.11b/g/n, cont.					Nominal Condition T = 25 °C, V _{CC} = 3.3V, 4.2V, and 5V, V _{REG} = 2.9V, Freq = 2450MHz, Duty Cycle 10 to 100% unless otherwise noted
Gain	31	34		dB	At nominal condition and V _{CC} = 5.0V (Over V _{REG} and Frequency)
	31	34		dB	At nominal condition and V _{CC} = 4.2V (Over V _{REG} and Frequency)
	31	34		dB	At nominal condition and V _{CC} = 3.3V (Over V _{REG} and Frequency)
Gain Variation over Temperature	-2		2	dB	-40 °C to +85 °C
Power Detector	+10		+29	dBm	Power detector usable range
Input Impedance		50		Ω	Input matched to 50Ω
Output P1dB		33		dBm	At nominal conditions with CW signal and V _{CC} = 5.0V
		32		dBm	At nominal conditions with CW signal and V _{CC} = 4.2V
		30.5		dBm	At nominal conditions with CW signal and V _{CC} = 3.3V
Power Down					
PA is "OFF"			0.6	V _{CC}	
PA is "ON"	1.75	2.9	5.0	V _{DC}	
Power Supply					
Operating Voltage		3 to 5		V	
Current Consumption		450	600	mA	RF P _{OUT} = +26dBm and V _{CC} = 5.0V (Over V _{REG} and frequency)
		175	225	mA	Idle current, No RF and V _{CC} = 5.0V (Over V _{REG} and frequency)
		400	475	mA	RF P _{OUT} = +25dBm and V _{CC} = 4.2V (Over V _{REG} and frequency)
		160	210	mA	Idle current, No RF and V _{CC} = 4.2V (Over V _{REG} and frequency)
		350	400	mA	RF P _{OUT} = +23.5dBm and V _{CC} = 3.3V (Over V _{REG} and frequency)
		150	180	mA	Idle current, No RF and V _{CC} = 3.3V (Over V _{REG} and frequency)
Power Down Current			10	mA	P _{DOWN} = Low, V _{REG} = High (I _{CC} + I _{BIAS} + I _{REG})
Leakage Current		0.2	1	mA	V _{REG} = P _{DOWN} = 0V, V _{CC} = 3.3V, RF = OFF (I _{CC} + I _{BIAS} + I _{REG})
V _{REG} Voltage (at Eval Board VREG pin)	2.8	2.9	3.0	VDC	Higher V _{REG} voltage is possible but with adjusting the series resistors to keep the voltage constant at VREG pin of Eval board at R1, R2 and R3
		5	10	mA	I _{REG} Current

Parameter	Specification			Unit	Condition
	Min.	Typ.	Max.		
WiMax IEEE 802.16e					Nominal Condition T = 25 °C, V _{CC} = 3.3V, 4.2V, 5V, V _{REG} = 2.9V, Freq = 2600MHz, Duty Cycle 1 to 100% unless otherwise noted
Frequency Range	2500		2700	MHz	
Compliance					IEEE 802.16e
Output Power	26	26.5		dBm	Measured standard IEEE 802.16e waveform (16QAM, 10MHz BW), V _{CC} = 5.0V
EVM		2.5	3	%	RMS, Mean
Output Power	25	25.5		dBm	Measured standard IEEE 802.16e waveform (16QAM, 10MHz BW), V _{CC} = 4.2V
EVM		2	3.0	%	RMS, Mean
Output Power	23.5	24		dBm	Measured standard IEEE 802.16e waveform (16QAM, 10MHz BW), V _{CC} = 3.3V
EVM		3	4	%	RMS, Mean
Gain	31	32		dB	At nominal condition and V _{CC} = 5.0V (Over V _{REG} and frequency)
	31	32		dB	At nominal condition and V _{CC} = 4.2V (Over V _{REG} and frequency)
	31	32		dB	At nominal condition and V _{CC} = 3.3V (Over V _{REG} and frequency)
Gain variation over temperature	-2		2	dB	-40 °C to +85 °C
Power Detector	+10		+29	dB	Power detector usable range
Low Gain Mode (Gain Reduction)		33		dB	At V _{CC} = 5.0V, V _{REG} 1 and 3 = 2.9V, V _{REG} 2 = Low, and Temp = 25 °C (In this mode, the gain of the power amplifier drops by 33dB typical from its original gain)
Input Impedance		50		Ω	Input matched to 50Ω
Output P1dB		33		dBm	At nominal conditions with CW Signal and V _{CC} = 5.0V
		32		dBm	At nominal conditions with CW Signal and V _{CC} = 4.2V
		30.5		dBm	At nominal conditions with CW Signal and V _{CC} = 3.3V
Power Down					
PA is "OFF"			0.6	V _{CC}	
PA is "ON"	1.75	2.9	5.0	V _{DC}	
Power Supply					
Operating Voltage		3 to 5		V	
Current Consumption		500	600	mA	RF P _{OUT} = +26dBm and V _{CC} = 5.0V (Over V _{REG} and frequency)
		175	225	mA	Idle current, No RF and V _{CC} = 5.0V (Over V _{REG} and frequency)
		400	475	mA	RF P _{OUT} = +25dBm and V _{CC} = 4.2V (Over V _{REG} and frequency)
		160	210	mA	Idle current, No RF and V _{CC} = 4.2V (Over V _{REG} and frequency)
		350	400	mA	RF P _{OUT} = +23.5dBm and V _{CC} = 3.3V (Over V _{REG} and frequency)
		150	180	mA	Idle current, No RF and V _{CC} = 3.3V (Over V _{REG} and frequency)

Parameter	Specification			Unit	Condition
	Min.	Typ.	Max.		
Power Supply, cont.					
Power Down Current			10	mA	$P_{\text{DOWN}} = \text{Low}$, $V_{\text{REG}} = \text{High}$ ($I_{\text{CC}} + I_{\text{BIAS}} + I_{\text{REG}}$)
Leakage Current		0.2	1	mA	$V_{\text{REG}} = P_{\text{DOWN}} = 0\text{V}$, $V_{\text{CC}} = 3.3\text{V}$, RF = OFF ($I_{\text{CC}} + I_{\text{BIAS}} + I_{\text{REG}}$)
VREG1, 2, 3 Voltage	2.8	2.9	3.0	V_{DC}	Higher V_{REG} voltage is possible but with adjusting the series resistors to keep the voltage constant at the pins.
		5	10	mA	I_{REG} Current
WiBro IEEE 802.16e					
Nominal Condition T = 25 °C, $V_{\text{CC}} = 3.3\text{V}$, 4.2V, 5.0V, $V_{\text{REG}} = 2.9\text{V}$, Freq = 2350MHz, Duty Cycle 1 to 100% unless otherwise noted					
Frequency Range	2300		2400	MHz	
Compliance					IEEE 802.16e
Output Power	26	26.5		dBm	Measured standard IEEE 802.16e waveform (16QAM, 10MHz BW), $V_{\text{CC}} = 5.0\text{V}$
EVM		2	3	%	RMS, Mean (Over V_{REG} and frequency)
Output Power	25	25.5		dBm	Measured standard IEEE 802.16e waveform (16QAM, 10MHz BW), $V_{\text{CC}} = 4.2\text{V}$
EVM		2	3	%	RMS, Mean (Over V_{REG} and frequency)
Output Power	23.5	24		dBm	Measured standard IEEE 802.16e waveform (16QAM, 10MHz BW), $V_{\text{CC}} = 3.3\text{V}$
EVM		3	4	%	RMS, Mean (Over V_{REG} and frequency)
Gain	32	34		dB	At nominal condition and $V_{\text{CC}} = 5.0\text{V}$
	32	34		dB	At nominal condition and $V_{\text{CC}} = 4.2\text{V}$
	32	34		dB	At nominal condition and $V_{\text{CC}} = 3.3\text{V}$
Gain variation over temperature	-2		2	±dB	-40 °C to +85 °C
Power Detector	+10		+29		Power detector usable range
Low Gain Mode (Gain Reduction)		33		dB	At $V_{\text{CC}} = 5.0\text{V}$, $V_{\text{REG}} 1$ and 3 = 2.9V, $V_{\text{REG}} 2 = \text{Low}$, and Temp = 25 °C (In this mode, the gain of the power amplifier drops by 33dB typical from its original gain)
Input Impedance		50		Ω	Input matched to 50 Ω
Output P1dB		33		dBm	At nominal conditions with CW Signal and $V_{\text{CC}} = 5.0\text{V}$
		32		dBm	At nominal conditions with CW Signal and $V_{\text{CC}} = 4.2\text{V}$
		30.5		dBm	At nominal conditions with CW Signal and $V_{\text{CC}} = 3.3\text{V}$
Power Down					
PA is OFF			0.6	V_{CC}	
PA is ON	1.75	2.9	5.0	V_{DC}	

Parameter	Specification			Unit	Condition
	Min.	Typ.	Max.		
Power Supply					
Operating Voltage		3 to 5		V	
Current Consumption		410	600	mA	RF P _{OUT} = +26dBm and V _{CC} = 5.0V (Over V _{REG} and frequency)
		175	225	mA	Idle Current, No RF and V _{CC} = 5.0V (Over V _{REG} and frequency)
		400	475	mA	RF P _{OUT} = +25dBm and V _{CC} = 4.2V (Over V _{REG} and frequency)
		160	210	mA	Idle Current, No RF and V _{CC} = 4.2V (Over V _{REG} and frequency)
		350	400	mA	RF P _{OUT} = +23.5dBm and V _{CC} = 3.3V (Over V _{REG} and frequency)
		150	180	mA	Idle Current, No RF and V _{CC} = 3.3V (Over V _{REG} and frequency)
Power Down Current			10	mA	P _{DOWN} = Low, V _{REG} = High (I _{CC} + I _{BIAS} + I _{REG})
Leakage Current		0.2	1	mA	V _{REG} = P _{DOWN} = 0V, V _{CC} = 3.3V, RF = OFF (I _{CC} + I _{BIAS} + I _{REG})
V _{REG} Voltage (at Eval Board VREG pin)	2.8	2.9	3	V _{DC}	Higher V _{REG} voltage is possible but with adjusting the series resistors to keep the voltage constant at VREG pin of the Eval board at R1, R2 and R3
		5	10	mA	I _{REG} Current
Thermal Data					
Maximum Junction Temperature for long term reliability, T _J Max		150		°C	P _{OUT} = 26dBm, Using a standard IEEE802.11g waveform, 54Mbps, 64QAM Duty Cycle = 100%, V _{CC} = 5VDC, V _{REG} = 2.85VDC. T _{REF} = 85 °C
Thermal Resistance, θ_{jc}		22		°C/W	P _{OUT} = 26dBm, Using a standard IEEE802.11g waveform, 54Mbps, 64QAM Duty Cycle = 100%, V _{CC} = 5VDC, V _{REG} = 2.85VDC, Junction to bottom of QFN package. T _{REF} = 85 °C
Thermal Resistance, θ_{j-Ref}		28		°C/W	P _{OUT} = 26dBm, Using a standard IEEE802.11g waveform, 54Mbps, 64QAM Duty Cycle = 100%, V _{CC} = 5VDC, V _{REG} = 2.85VDC, Junction to bottom of PCB. T _{REF} = 85 °C
ESD					
Human Body Model	500			V	
Charge Device Model	750			V	

Pin	Function	Description
1	BIAS VCC	Supply voltage for the bias reference and control circuits. May be connected with VCC1 and VCC2 as long as V_{CC} does not exceed $5.0V_{DC}$ in this configuration.
2	RF IN	RF input.
3	PDOWN	Power down pin. Apply $<0.6V_{DC}$ to power down the three power amplifier stages. Apply $1.75V_{DC}$ to $5.0V_{DC}$ to power up. If function is not desired, pin may be connected to V_{REG} .
4	VREG1	First stage input bias voltage. This pin requires a regulated supply to maintain nominal bias current.
5	VREG2	Second stage input bias voltage. This pin requires a regulated supply to maintain nominal bias current.
6	VREG3	Third stage input bias voltage. This pin requires a regulated supply to maintain nominal bias current.
7	NC	Not connected. May be connected to ground.
8	P DETECT	Power detector provides an output voltage proportional to the RF output power level.
9	NC	Not connected. May be connected to ground.
10	VCC3/ RF OUT	RF output and bias for the output stage. Output is externally matched to 50Ω and needs DC block.
11	VCC3/ RF OUT	Same as pin 10.
12	VCC3/ RF OUT	Same as pin 10.
13	VCC2	Second stage supply voltage.
14	VCC2	Same as pin 13.
15	NC	Not connected. May be connected to ground.
16	VCC1	First stage supply voltage.
Pkg Base	GND	Ground connection. The back side of the package should be connected to the ground plane through as short a connection as possible, e.g., PCB vias under the device are recommended.

Package Outline

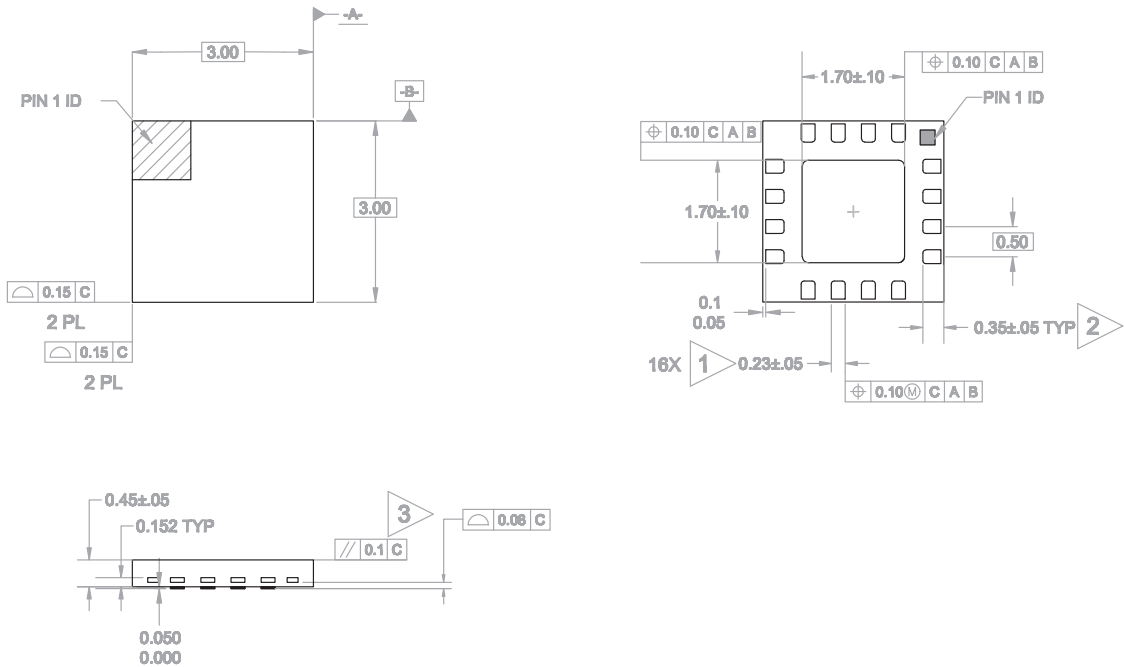

Notes:

1. Dimension applies to metallized terminal and is measured between 0.25mm and 0.30mm from terminal tip.
2. Dimension represents terminal pull back from package edge up to 0.1mm is acceptable.
3. Complanarity applies to the exposed heat slug, as well as the terminal.
4. Radius on terminal is optional.

PCB Design Requirements

PCB Surface Finish

The PCB surface finish used for RFMD's qualification process is electroless nickel, immersion gold. Typical thickness is 3 micro-inch to 8 micro-inch gold over 180 micro-inch nickel.

PCB Land Pattern Recommendation *

PCB land patterns for RFMD components are based on IPC-7351 standards and RFMD empirical data. The pad pattern shown has been developed and tested for optimized assembly at RFMD. The PCB land pattern has been developed to accommodate lead and package tolerances. Since surface mount processes vary from company to company, careful process development is recommended.

PCB Metal Land Pattern

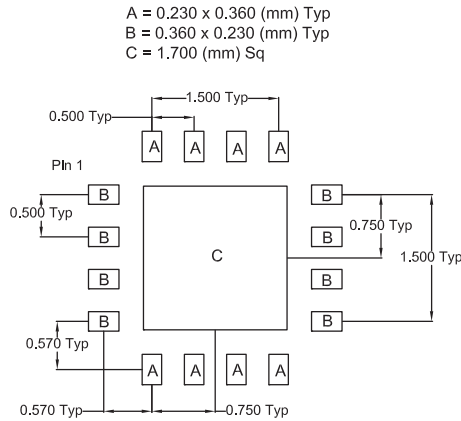

PCB Solder Mask Pattern

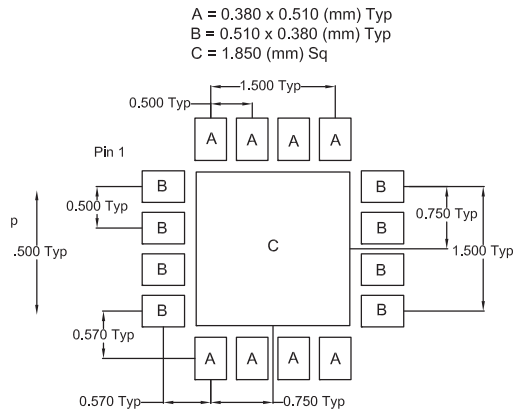

PCB Stencil Pattern

A = 0.207 x 0.324 (mm) Typ
 B = 0.324 x 0.207 (mm) Typ
 C = 1.530 (mm) Sq

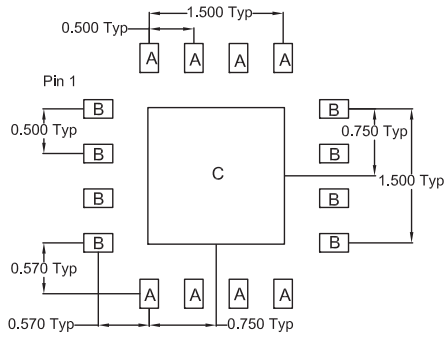

Note: Thermal vias for center slug “C” should be incorporated into the PCB design. The number and size of thermal vias will depend on the application. Example of the number and size of vias can be found on the RFMD evaluation board layout.

Note: If it is desired to build the same PCB to accommodate the RF5602 as well as the RF5623/RF5603 use the following PCB Patterns.

PCB Design Requirements

PCB Metal Land Pattern

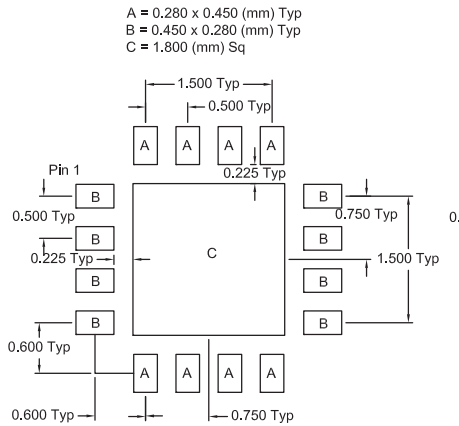

PCB Solder Mask Pattern

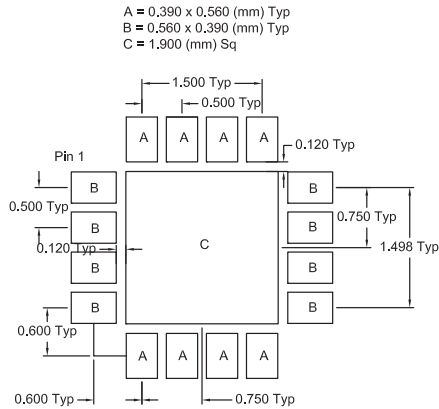

PCB Stencil Pattern

A = 0.252 x 0.405 (mm) Typ
 B = 0.405 x 0.252 (mm) Typ
 C = 1.620 (mm) Sq

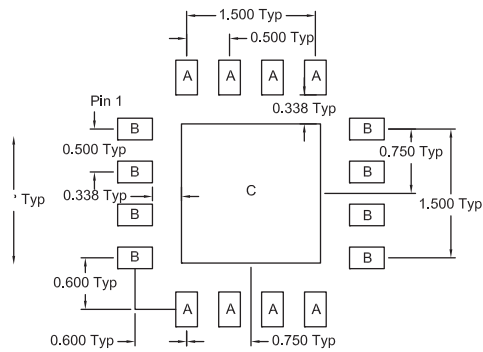

Note: Thermal vias for center slug "C" should be incorporated into the PCB design. The number and size of thermal vias will depend on the application. Example of the number and size of vias can be found on the RFMD evaluation board layout.

Pin Out

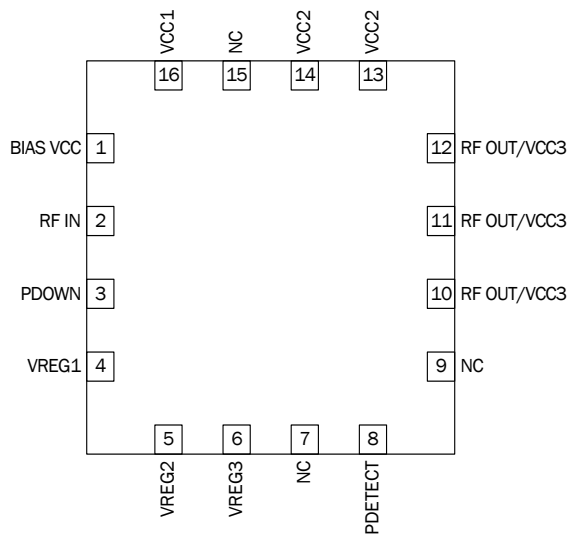

Evaluation Board Schematic WiFi 2.4GHz to 2.5GHz Operation

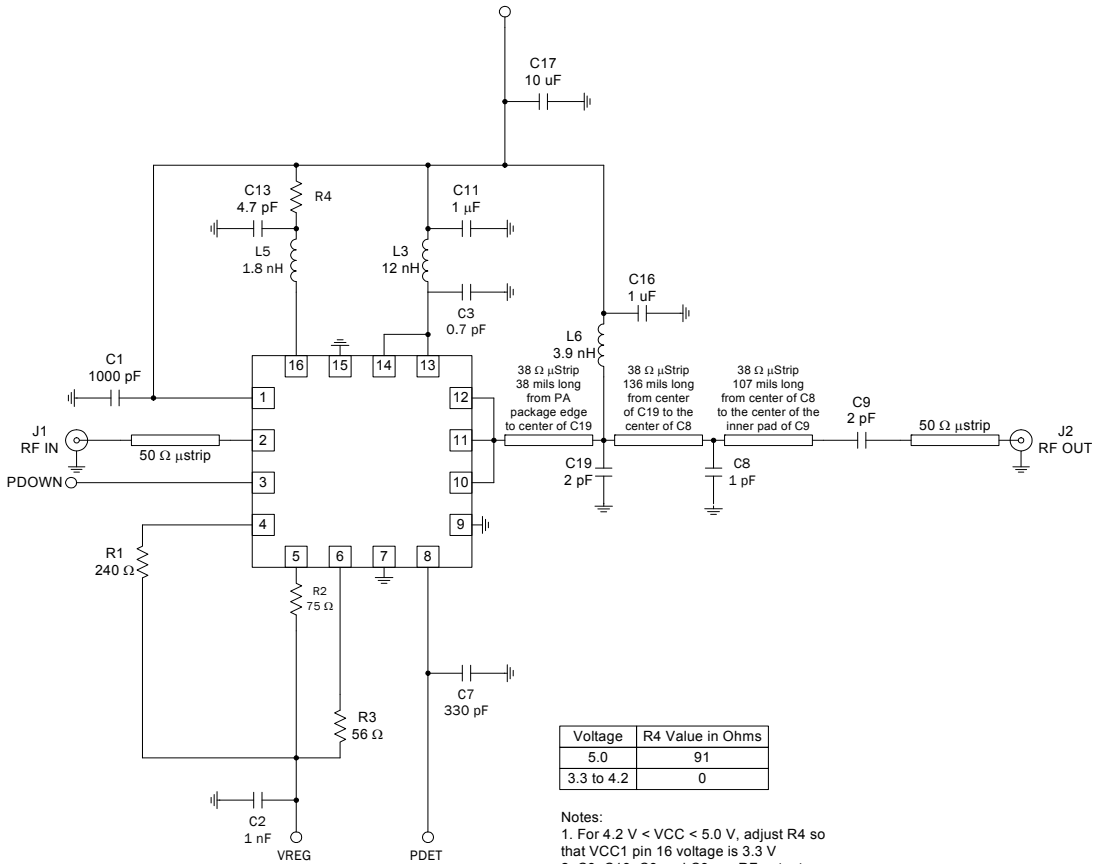

Voltage	R4 Value in Ohms
5.0	91
3.3 to 4.2	0

- Notes:
- For 4.2 V < VCC < 5.0 V, adjust R4 so that VCC1 pin 16 voltage is 3.3 V
 - C3, C19, C8 and C9 are RF output matching Cap, that might need fine tune for best performance on PCB with materials different to that of RFMD Eval board

Evaluation Board Layout
 WiFi 2.4GHz to 2.5GHz Operation
 (FR4, 8mils thickness top layer)

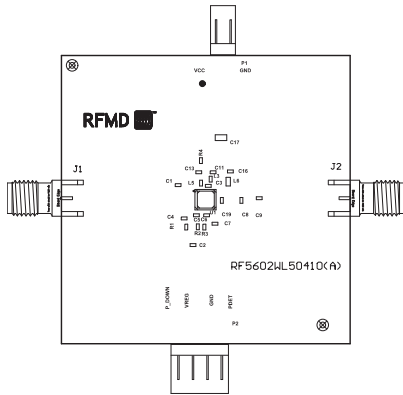

Assy

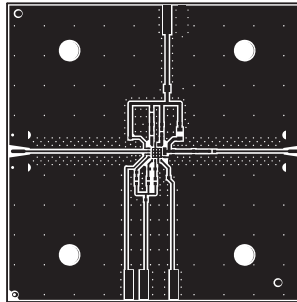

In 1

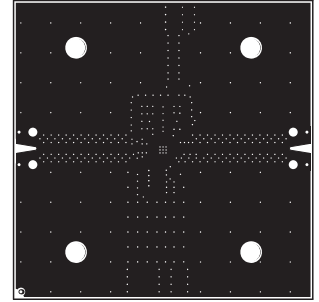

In 2

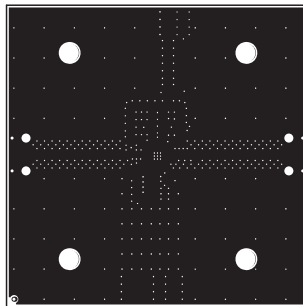

In 2

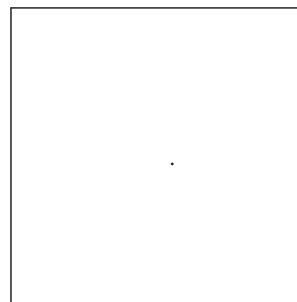

Back

Evaluation Board Schematic

WiMAX 2.5GHz to 2.7GHz Operation

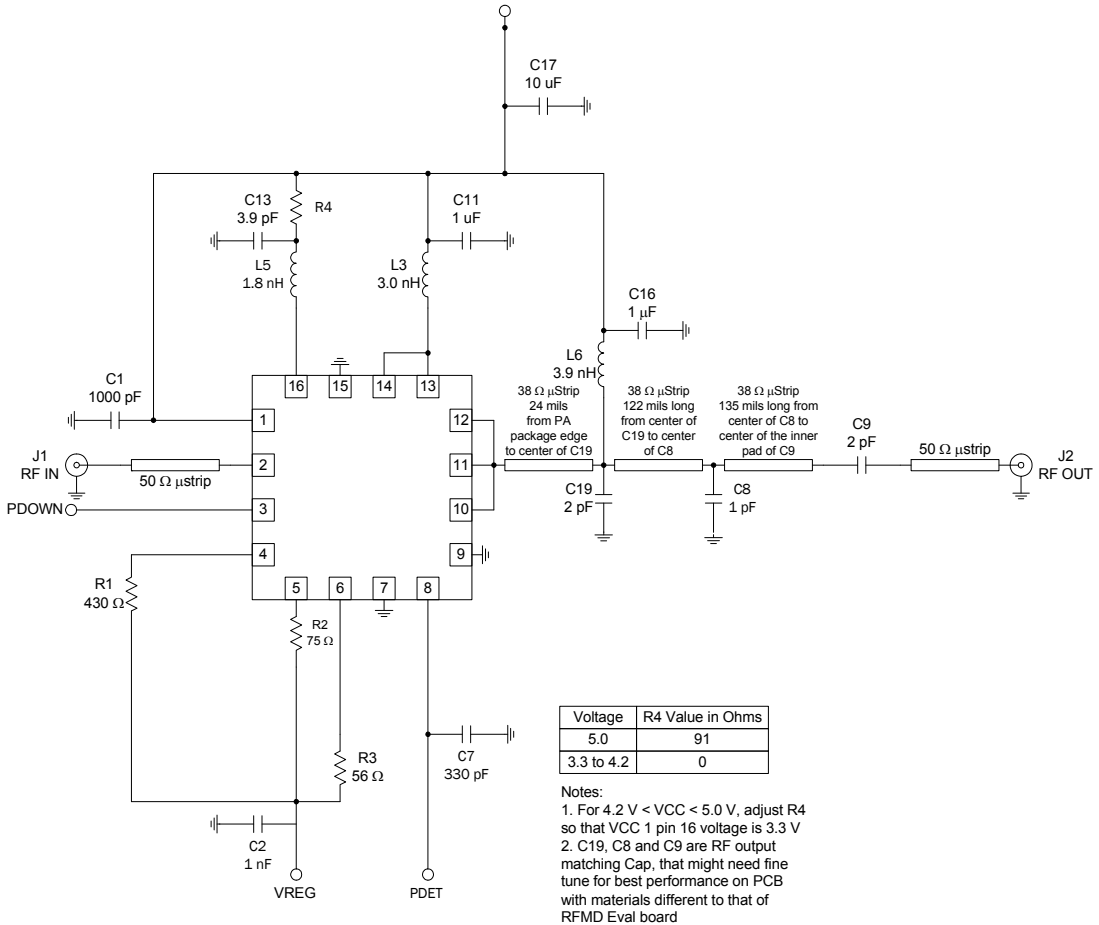

Evaluation Board Layout
WiMAX 2.5GHz to 2.7GHz Operation
(FR4, 8mils thickness top layer)

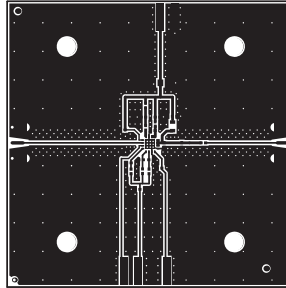
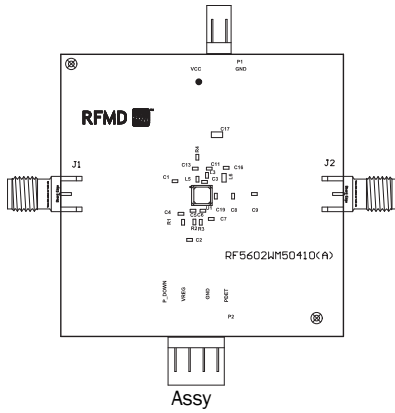

Top

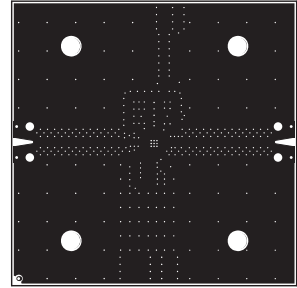

In 1

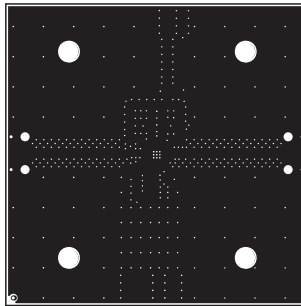

In 2

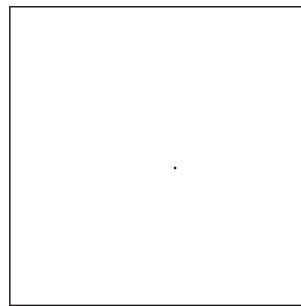

Back

Evaluation Board Layout
WiBro 2.3GHz to 2.4GHz Operation
(FR4, 8mils thickness)

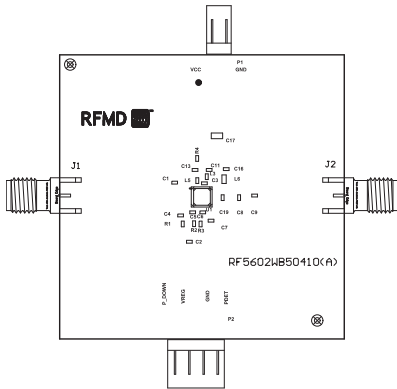

Assy

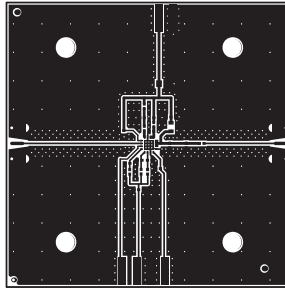

Top

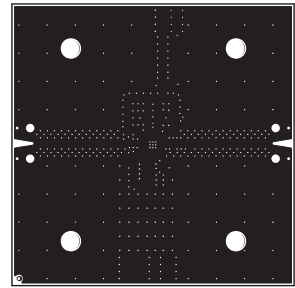

In 1

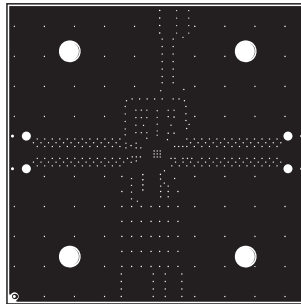

In 2

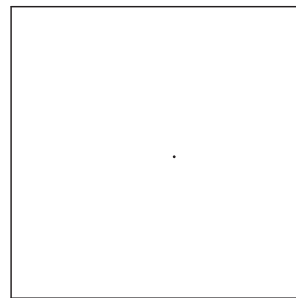

Back

Typical WiFi EVM and Gain versus P_{OUT}
2.4GHz to 2.5GHz Tune at $V_{CC} = 5.0V$

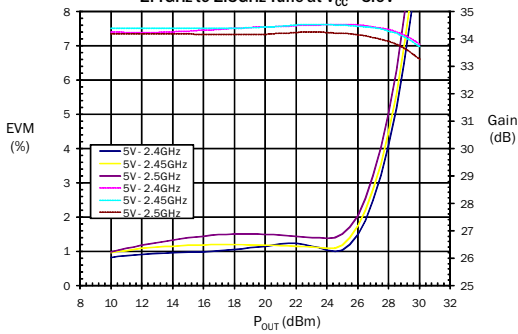

WiFi EVM and Gain versus P_{OUT}
2.45GHz over temperature at $V_{CC} = 5.0V$

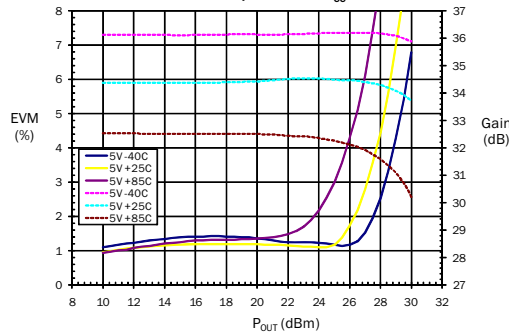

Typical WiFi I_{CC} versus P_{OUT}
2.4GHz to 2.5GHz Tune at $V_{CC} = 5.0V$

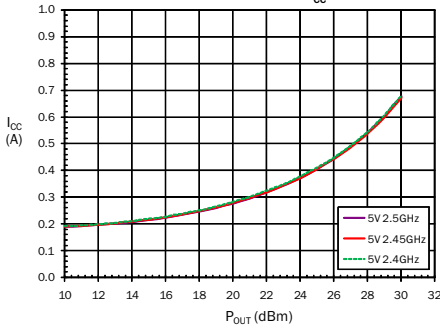

Typical WiFi I_{CC} versus P_{OUT}
2.45GHz over temperature at $V_{CC} = 5.0V$

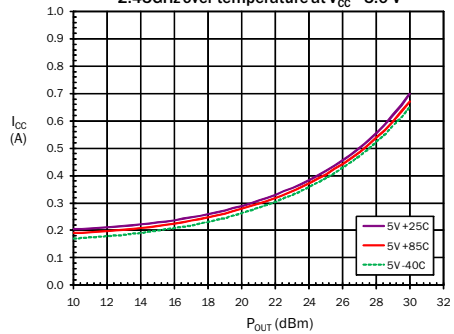

Typical WiFi PDET versus P_{OUT}
2.4GHz to 2.5 GHz Tune at $V_{CC} = 5.0V$

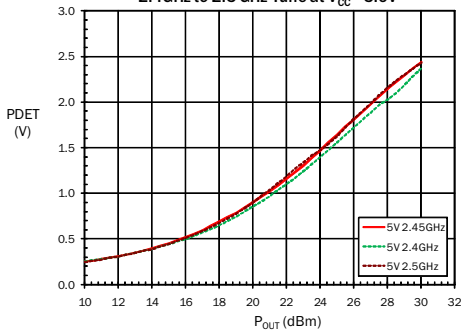

Typical WiFi PDET versus P_{OUT}
2.45 GHz over temperature at $V_{CC} = 5.0V$

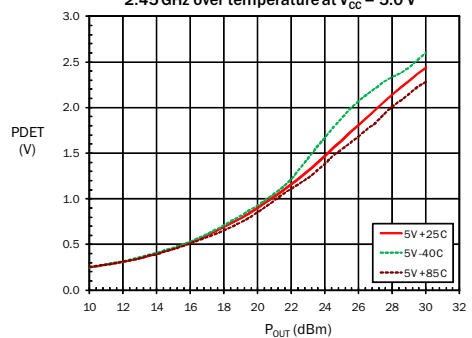

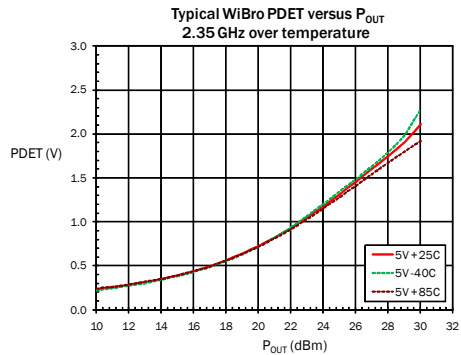
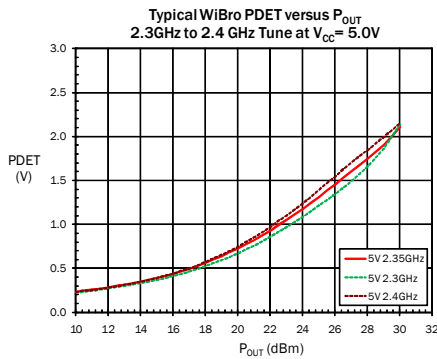
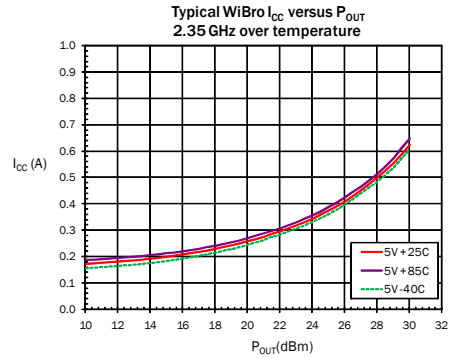
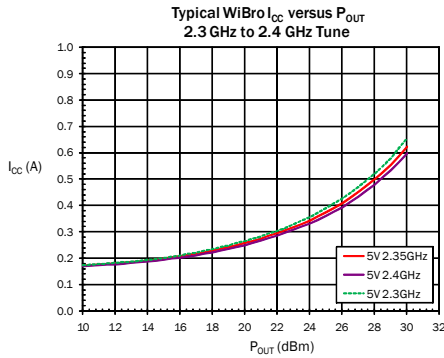
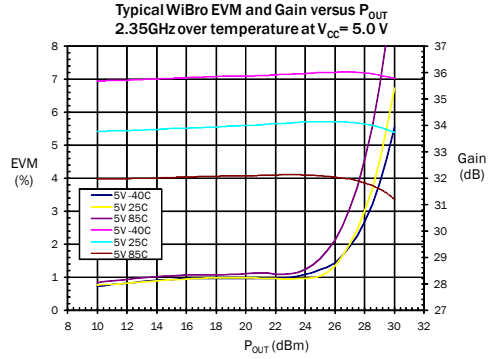
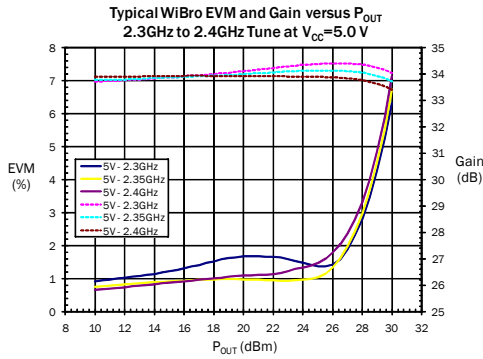

Typical WiMAX EVM and Gain versus P_{OUT}
2.5GHz to 2.7GHz Tune at $V_{CC}=5.0V$

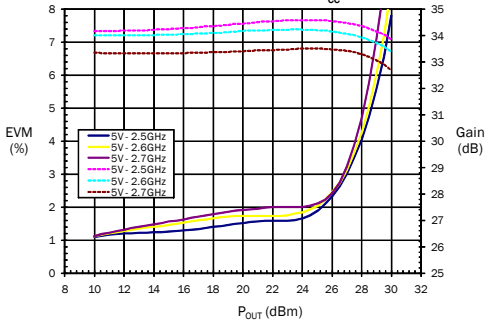

Typical WiMAX EVM and Gain versus P_{OUT}
2.6GHz over temperature at $V_{CC}=5.0V$

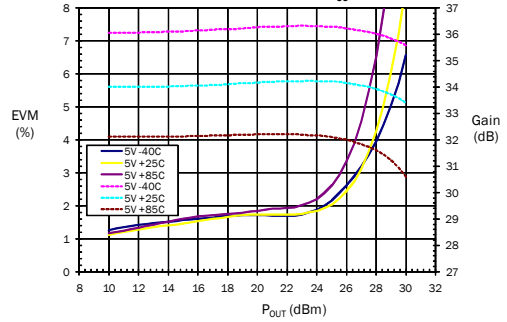

Typical WiMax I_{CC} versus P_{OUT}
2.5 GHz to 2.7 GHz Tune at $V_{CC}=5.0V$

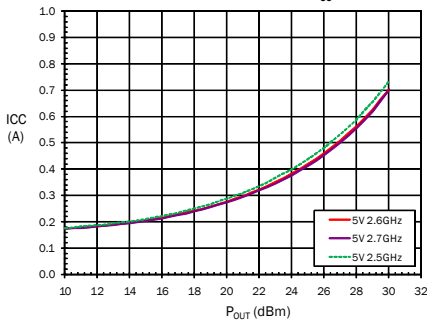

Typical WiMax I_{CC} versus P_{OUT}
2.6GHz over temperature $V_{CC}=5.0V$

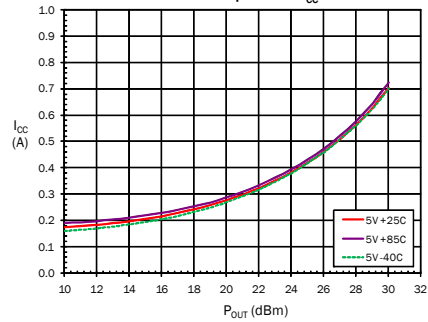

Typical WiMax PDET versus P_{OUT}
2.5GHz to 2.7 GHz Tune at $V_{CC}=5.0V$

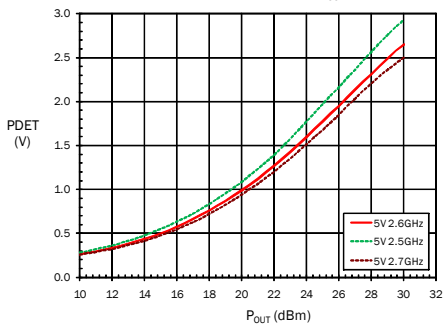

Typical WiMax PDET versus P_{OUT}
2.6GHz over temperature at $V_{CC}=5.0V$

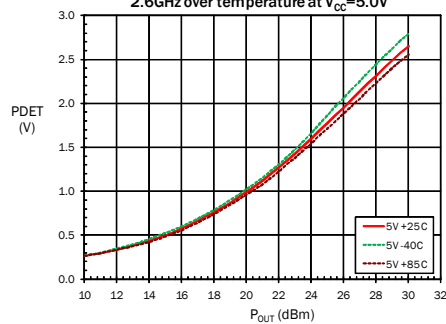

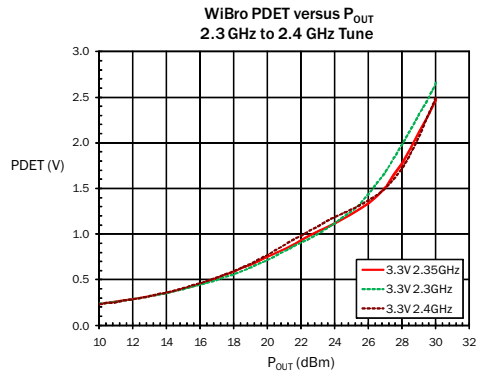
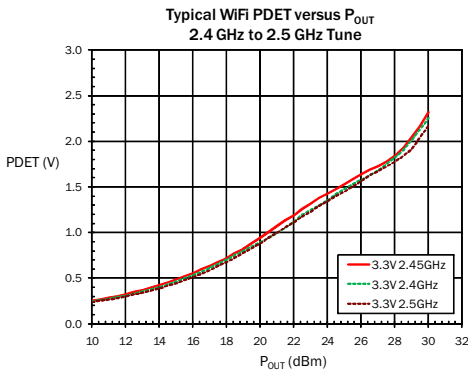
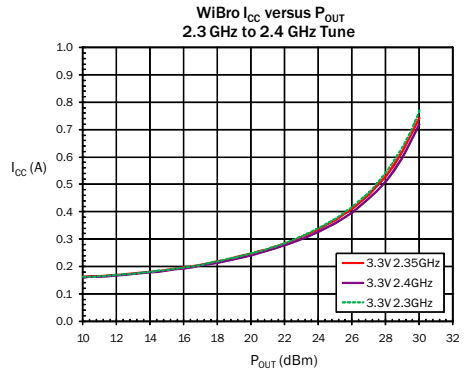
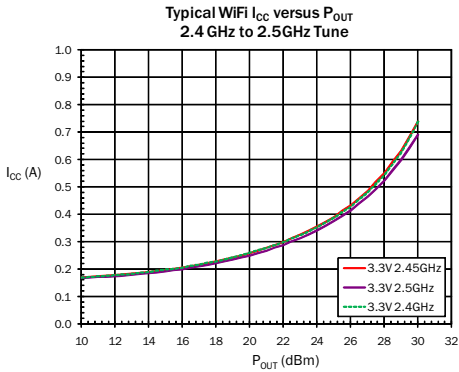
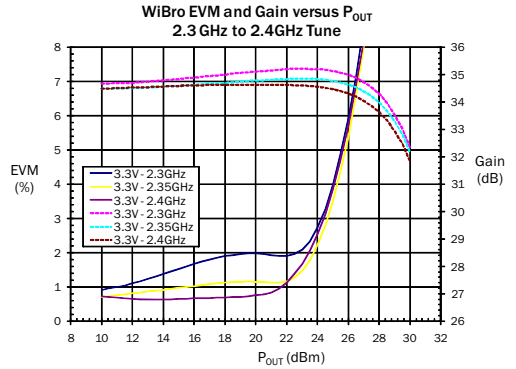
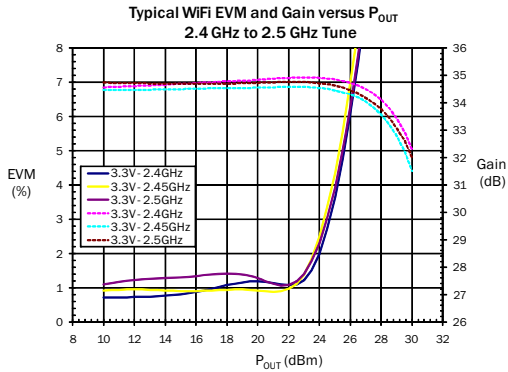

Typical WiMAX EVM and Gain versus P_{OUT}
2.5 GHz to 2.7 GHz Tune

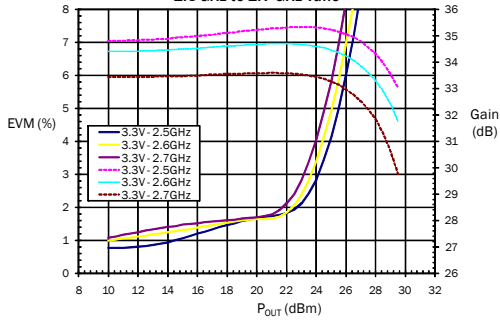

Typical WiMAX EVM and Gain versus P_{OUT}
2.5 GHz to 2.7 GHz Tune

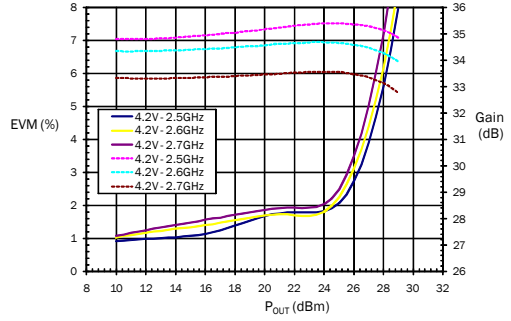

Typical WiMax I_{CC} versus P_{OUT}
2.5 GHz to 2.7 GHz Tune

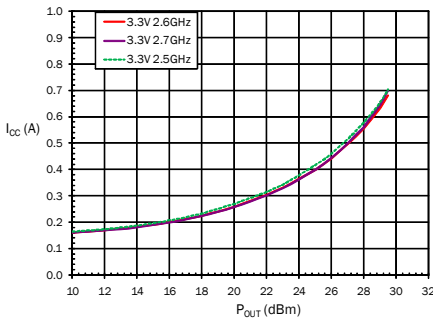

Typical WiMax I_{CC} versus P_{OUT}
2.5 GHz to 2.7 GHz Tune

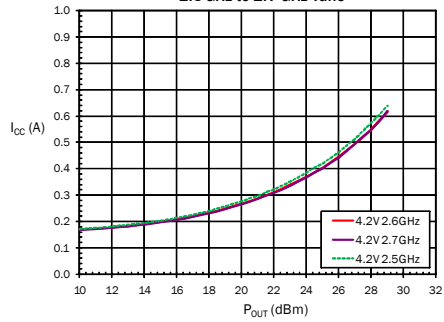

Typical WiMax PDET versus P_{OUT}
2.5 GHz to 2.7GHz Tune

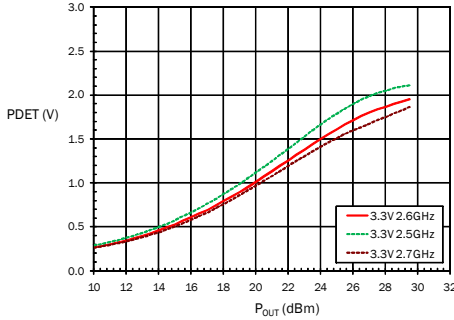

Typical WiMax PDET versus P_{OUT}
2.5 GHz to 2.7 GHz Tune

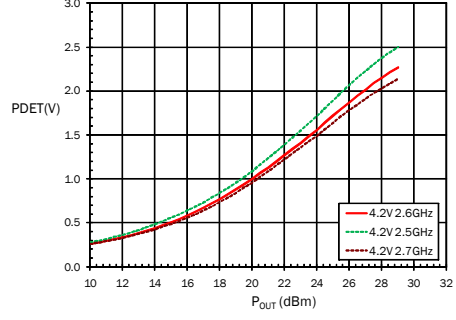

Typical WiFi EVM and Gain versus P_{OUT}
2.4 GHz to 2.5GHz Tune

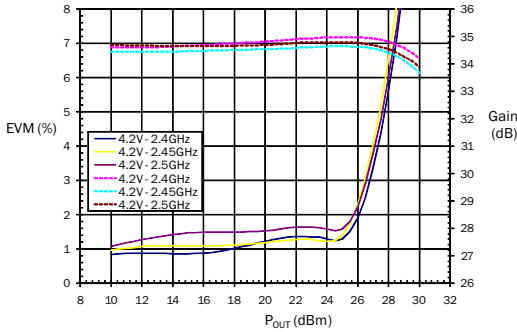

Typical WiBro EVM and Gain versus P_{OUT}
2.3 GHz to 2.4GHz Tune

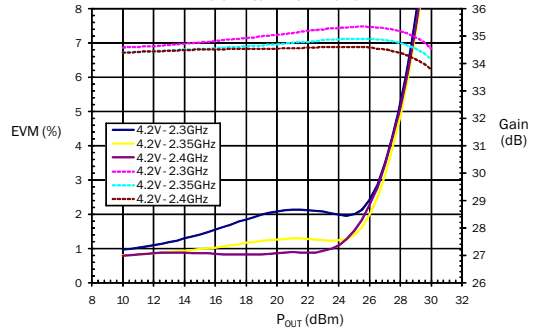

Typical WiFi I_{CC} versus P_{OUT}
2.4 GHz to 2.5GHz Tune

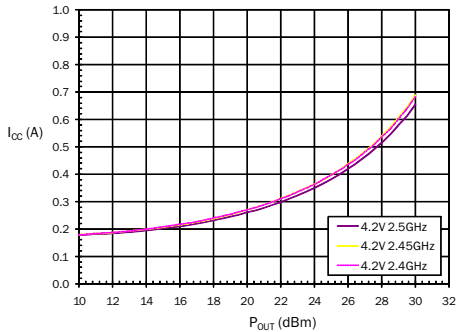

Typical WiBro I_{CC} versus P_{OUT}
2.3 GHz to 2.4 GHz Tune

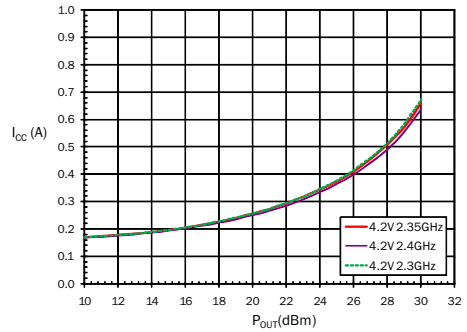

Typical WiFi PDET versus P_{OUT}
2.4 GHz to 2.5 GHz Tune

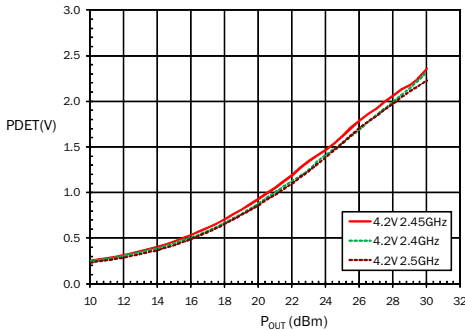

Typical WiBro PDET versus P_{OUT}
2.3 GHz to 2.4 GHz Tune

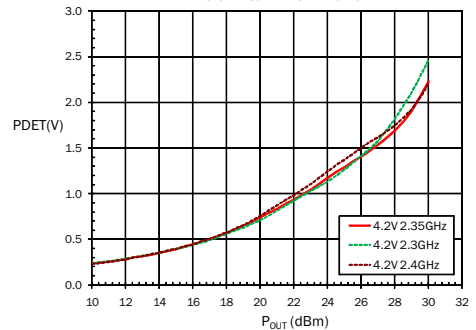

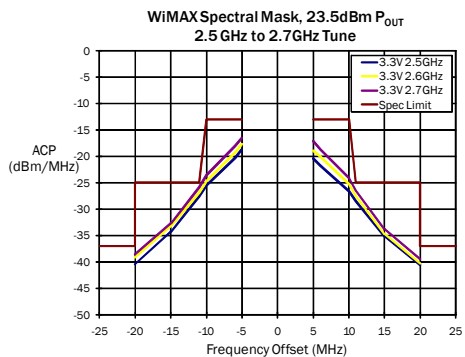
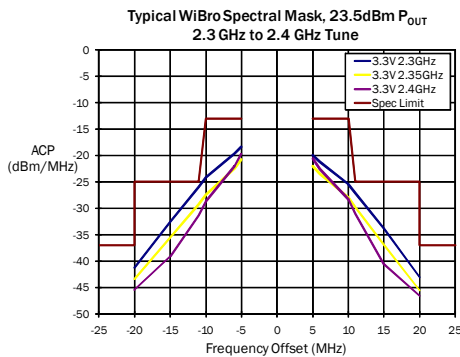
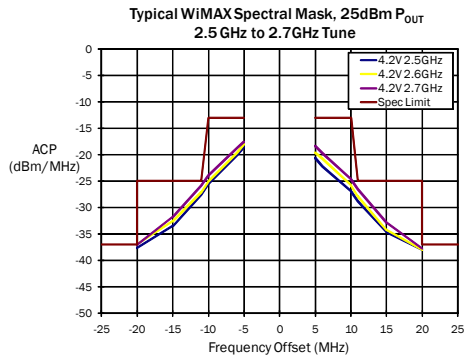
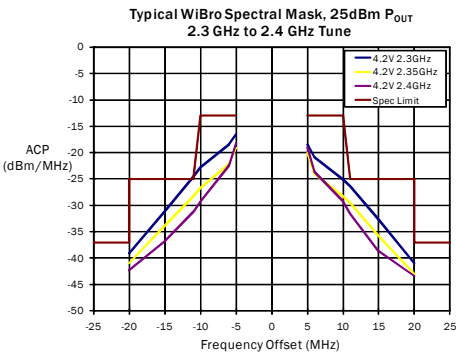
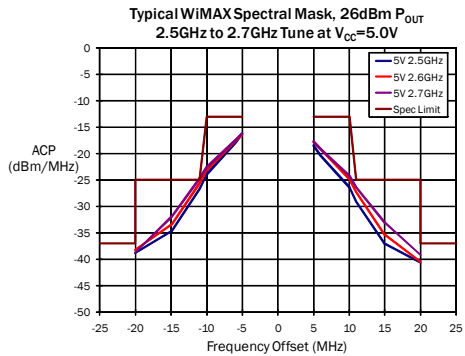
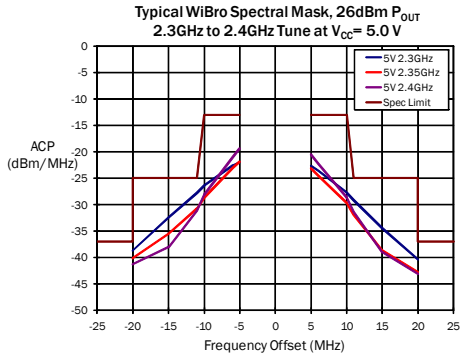

Ordering Information

Part Number	Description
RF5602	Standard 25 piece bag
RF5602SR	Standard 100 piece reel
RF5602TR7	Standard 2500 piece reel
RF5602WM50PCK-410	Fully assembled RF5602WM50410 5.0 volts tune PCBA and 5 loose pcs for WiMAX tune 2.5GHz to 2.7GHz
RF5602WM33PCK-410	Fully assembled RF5602WM33410 3.3 volts tune PCBA and 5 loose pcs for WiMAX tune 2.5GHz to 2.7GHz
RF5602WL50PCK-410	Fully assembled RF5602WL50410 5.0 volts tune PCBA and 5 loose pcs for WiFi tune 2.4GHz to 2.5GHz
RF5602WL33PCK-410	Fully assembled RF5602WL33410 3.3 volts tune PCBA and 5 loose pcs for WiFi tune 2.4GHz to 2.5GHz
RF5602WB50PCK-410	Fully assembled RF5602WB50410 5.0 volts tune PCBA and 5 loose pcs for WiBro tune 2.3GHz to 2.4GHz
RF5602WB33PCK-410	Fully assembled RF5602WB33410 3.3 volts tune PCBA and 5 loose pcs for WiBro tune 2.3GHz to 2.4GHz
RF5602HWBPCK-410	Fully assembled balanced evaluation board with 5 loose samples tuned for 2.3 to 2.4GHz
RF5602HWLPCK-410	Fully assembled balanced evaluation board with 5 loose samples tuned for 2.4 to 2.5GHz
RF5602HWPCK-410	Fully assembled balanced evaluation board with 5 loose samples tuned for 2.5 to 2.7GHz