



**Features**

- High Gain; 32dB
- 2.5% EVM (RMS) at 26dBm, 5.0V
- Integrated Power Detector
- High Impedance Enable
- Integrated Input Match
- Footprint compatible to RF5602

**Applications**

- WiMAX Customer Premises Equipment
- WiMAX Access Points
- IEEE 802.16 WiMAX Systems

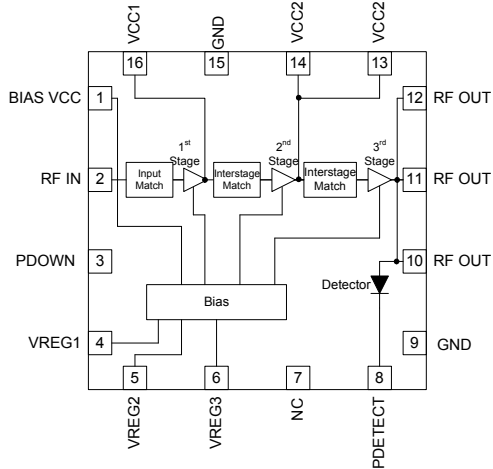

Functional Block Diagram

**Product Description**

The RF5623 is a linear power amplifier IC designed specifically for WiMAX medium power applications. The device is manufactured on an advanced InGaP Heterojunction Bipolar Transistor (HBT) process, and has been designed for use as the final RF amplifier in 802.16e transmitters. The device is provided in a 3mmx3mmx0.45mm, 16-pin, leadless chip carrier with a backside ground. The RF5623 is designed to maintain linearity over a wide range of conditions and power outputs.

**Optimum Technology Matching® Applied**

- |   |                                      |                                     |                                   |
|---|--------------------------------------|-------------------------------------|-----------------------------------|
| <input type="checkbox"/> GaAs HBT             | <input type="checkbox"/> SiGe BiCMOS | <input type="checkbox"/> GaAs pHEMT | <input type="checkbox"/> GaN HEMT |
| <input type="checkbox"/> GaAs MESFET          | <input type="checkbox"/> Si BiCMOS   | <input type="checkbox"/> Si CMOS    | <input type="checkbox"/> RF MEMS  |
| <input checked="" type="checkbox"/> InGaP HBT | <input type="checkbox"/> SiGe HBT    | <input type="checkbox"/> Si BJT     | <input type="checkbox"/> LDMOS    |

RF MICRO DEVICES®, RFMD®, Optimum Technology Matching®, Enabling Wireless Connectivity™, PowerStar®, POLARIS™ TOTAL RADIO™ and UltimateBlue™ are trademarks of RFMD, LLC. BLUETOOTH is a trademark owned by Bluetooth SIG, Inc., U.S.A. and licensed for use by RFMD. All other trade names, trademarks and registered trademarks are the property of their respective owners. ©2006, RF Micro Devices, Inc.

## Absolute Maximum Ratings

Parameter	Rating	Unit
Supply Voltage (RF Applied)	-0.5 to +5.25	V
Supply Voltage (No RF Applied)	-0.5 to +6.0	V
DC Supply Current	850	mA
Input RF Power	+10*	dBm
Operating Ambient Temperature	-40 to +85	°C
Storage Temperature	-40 to +150	°C
Moisture Sensitivity	MSL1	



**Caution!** ESD sensitive device.

Exceeding any one or a combination of the Absolute Maximum Rating conditions may cause permanent damage to the device. Extended application of Absolute Maximum Rating conditions to the device may reduce device reliability. Specified typical performance or functional operation of the device under Absolute Maximum Rating conditions is not implied.

RoHS status based on EUDirective2002/95/EC (at time of this document revision).

The information in this publication is believed to be accurate and reliable. However, no responsibility is assumed by RF Micro Devices, Inc. ("RFMD") for its use, nor for any infringement of patents, or other rights of third parties, resulting from its use. No license is granted by implication or otherwise under any patent or patent rights of RFMD. RFMD reserves the right to change component circuitry, recommended application circuitry and specifications at any time without prior notice.

\*Note: Maximum input power with a 50Ω load.

Parameter	Specification			Unit	Condition
	Min.	Typ.	Max.		
<b>Compliance WiMAX IEEE802.16e</b>					Nominal Condition T=25 °C, V <sub>CC</sub> =5.0V, V <sub>REG</sub> =2.85V, Freq=Full frequency range and duty cycle=37.029% unless otherwise specified. 802.16e 16QAM modulation with 10MHz BW signal
Frequency Range	3.3		3.6	GHz	
	3.6		3.8	GHz	
Output Power		26		dBm	
EVM		2.5	3.5	%	at P <sub>OUT</sub> =26dBm
Operating Current		600	700	mA	
Quiescent Current		380	470	mA	V <sub>CC</sub> =5.0V, V <sub>REG</sub> =2.85V, RF=Off
I <sub>REG</sub>			10	mA	
P <sub>DOWN</sub> Current			10	mA	
Leakage Current			1	mA	V <sub>CC</sub> =5.0V, V <sub>REG</sub> =0V, RF=Off
Gain	28	32		dB	at Rated output Power
Gain Variation over Temperature		2		±dB	-40 °C to +85 °C
Low Gain Mode (Gain Reduction)		25		dB	at V <sub>CC</sub> =5.0V, V <sub>REG</sub> 1 and 3=2.85V, V <sub>REG</sub> 2= Low and Temp=25 °C (In this mode the gain of the power amplifier drops by TBD typical from its original gain)
Power Detector	10		29	dBm	Useable power detection range
Input Return Loss		-15	-10	dB	
Output P1dB		32		dBm	with CW signal at V <sub>CC</sub> =5.0V
Turn-On Time		0.5	1.0	us	Output stable to within 90% of final gain
<b>Thermal Data</b>					
Maximum Junction Temperature for long term reliability, T <sub>J</sub> Max		150		°C	P <sub>OUT</sub> =26 dBm, V <sub>CC</sub> =5VDC, V <sub>REG</sub> =2.85VDC, T <sub>REF</sub> = 85 °C
Thermal Resistance, Θ <sub>Jc</sub>		23.7		°C/W	P <sub>OUT</sub> =26 dBm, V <sub>CC</sub> =5VDC, V <sub>REG</sub> =2.85VDC, Junction to bottom of QFN package. T <sub>REF</sub> = 85 °C
Thermal Resistance, Θ <sub>J-Ref</sub>		29.7		°C/W	P <sub>OUT</sub> =26 dBm, V <sub>CC</sub> =5VDC, V <sub>REG</sub> =2.85VDC, Junction to bottom of PCB. T <sub>REF</sub> = 85 °C
Human Body Model	1000			V	
Charge Device Model	1000			V	

Pin	Function	Description
1	BIAS VCC	Supply voltage for the bias reference and control circuits. May be connected with VCC1 and VCC2 as long as $V_{CC}$ does not exceed $5.0V_{DC}$ in this configuration.
2	RF IN	RF input, internally matched and DC block is provided.
3	PDOWN	Power down pin. Apply $<0.6V_{DC}$ to power down the three power amplifier stages. Apply $1.75V_{DC}$ to $5.0V_{DC}$ to power up. If function is not desired, pin may be connected to $V_{REG}$ .
7, 9, 15	NC	Not connected. May be connected to ground.
4	VREG1	First stage input bias voltage. This pin requires a regulated supply to maintain nominal bias current.
5	VREG2	Second stage input bias voltage. This pin requires a regulated supply to maintain nominal bias current.
6	VREG3	Third stage input bias voltage. This pin requires a regulated supply to maintain nominal bias current.
8	P DETECT	Power detector provides an output voltage proportional to the RF output power level.
10, 11, 12	VCC3/RF OUT	RF output and bias for the output stage. Output is externally matched to $50\Omega$ and needs DC block.
13, 14	VCC2	Second stage supply voltage.
16	VCC1	First stage supply voltage.
Pkg Base	GND	Ground connection. The back side of the package should be connected to the ground plane through as short a connection as possible, e.g., PCB vias under the device are recommended.

**Package Outline**

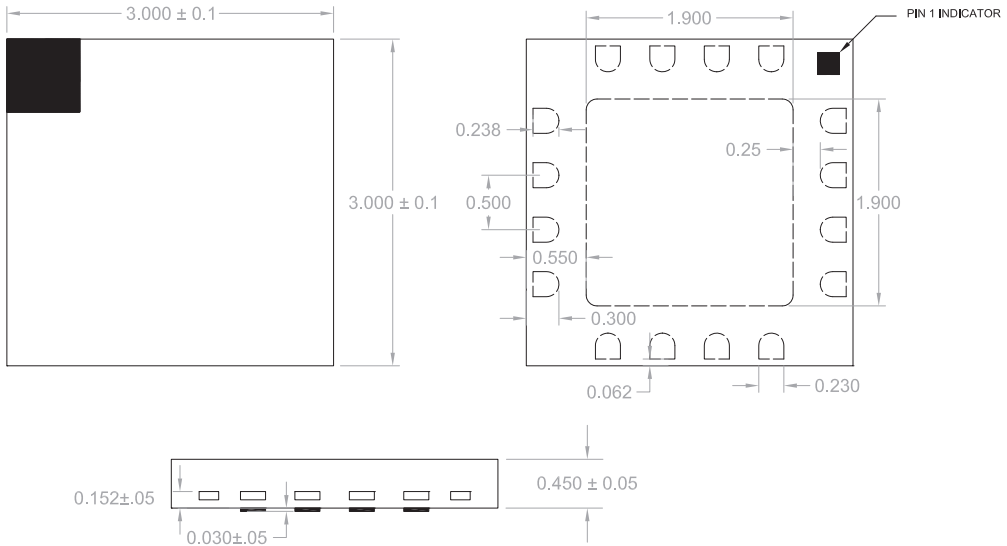

NOTES:

- 1 Shaded Area is Pin 1 Indicator

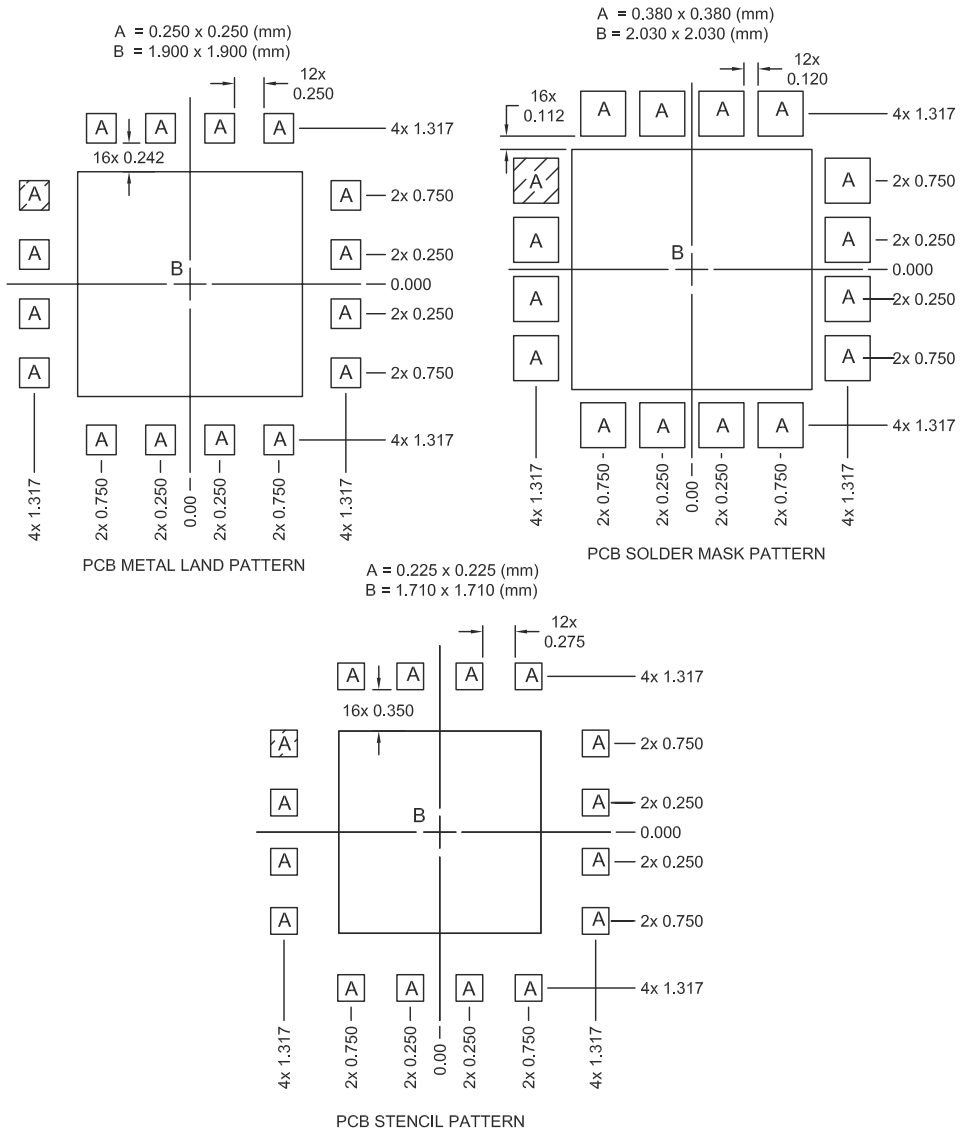

Shaded are represents Pin 1 location.

**Note:** Thermal vias for center slug "B" should be incorporated into the PCB design. The number and size of thermal vias will depend on the application, the power dissipation, and the electrical requirements. Example of the number and size of vias can be found on the RFMD evaluation board layout.

**PCB Metal Land and Solder Mask Pattern**

Note: If it is desired to build the same PCB to accommodate the RF5602 as well as the RF5623/RF5603 use the following PCB Patterns.

A = 0.280 x 0.450 (mm) Typ  
 B = 0.450 x 0.280 (mm) Typ  
 C = 1.800 (mm) Sq

A = 0.390 x 0.560 (mm) Typ  
 B = 0.560 x 0.390 (mm) Typ  
 C = 1.900 (mm) Sq

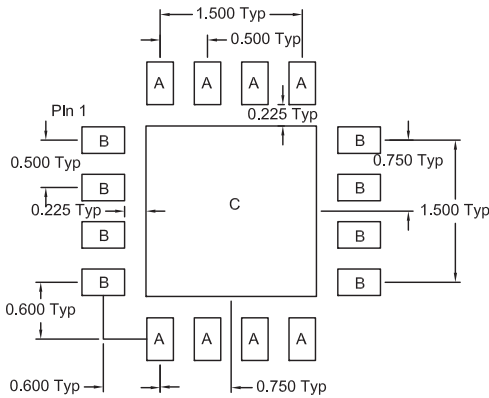

PCB METAL LAND PATTERN

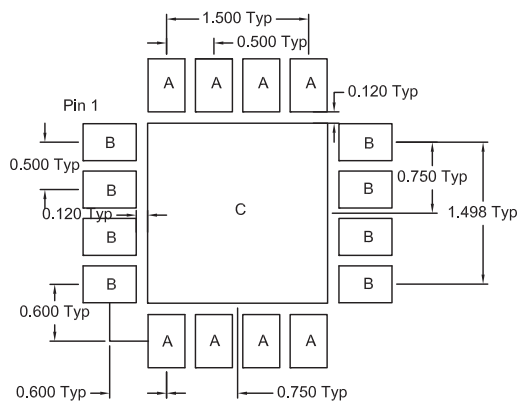

PCB SOLDER MASK PATTERN

A = 0.252 x 0.405 (mm) Typ  
 B = 0.405 x 0.252 (mm) Typ  
 C = 1.620 (mm) Sq

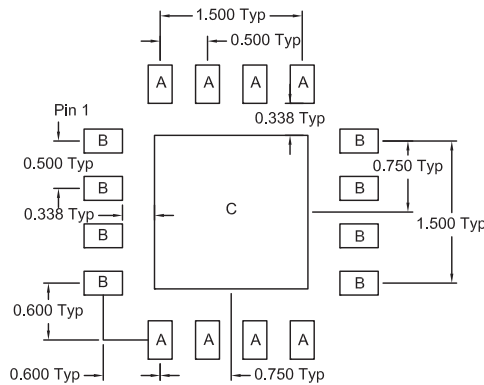

PCB STENCIL PATTERN

Note: Thermal vias for center slug "C" should be incorporated into the PCB design. The number and size of thermal vias will depend on the application. Example of the number and size of vias can be found on the RFMD evaluation board layout.

## Pin Out

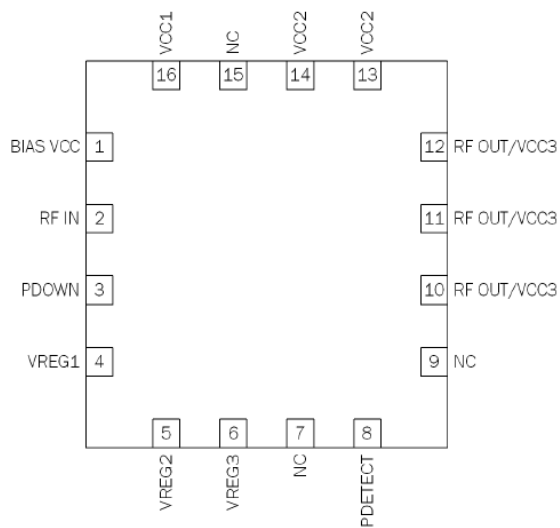

**3.3GHz to 3.6GHz Schematic**

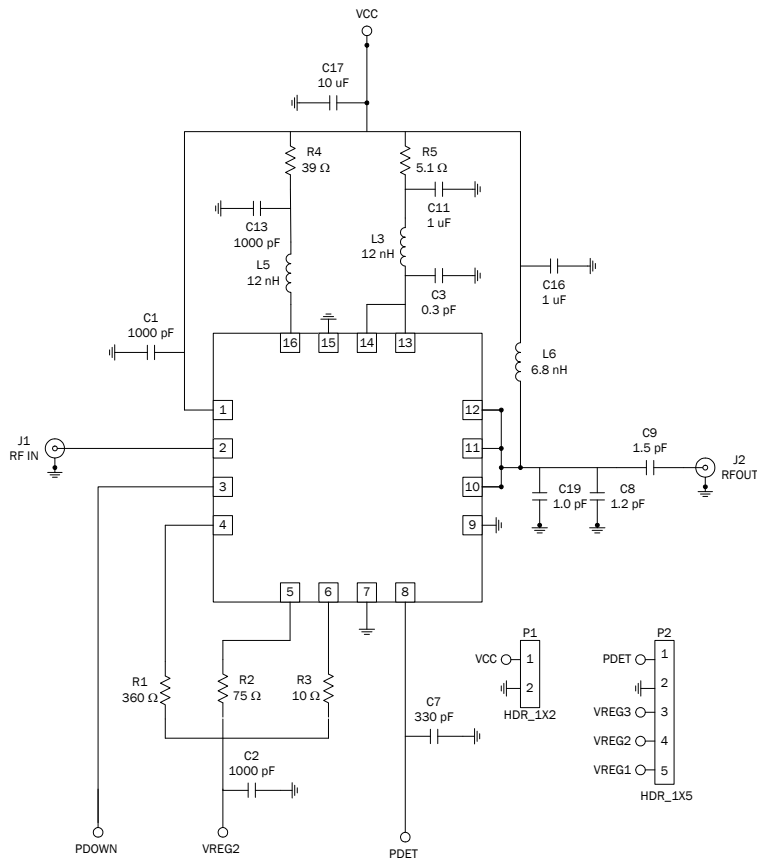

## 3.6GHz to 3.8GHz Schematic

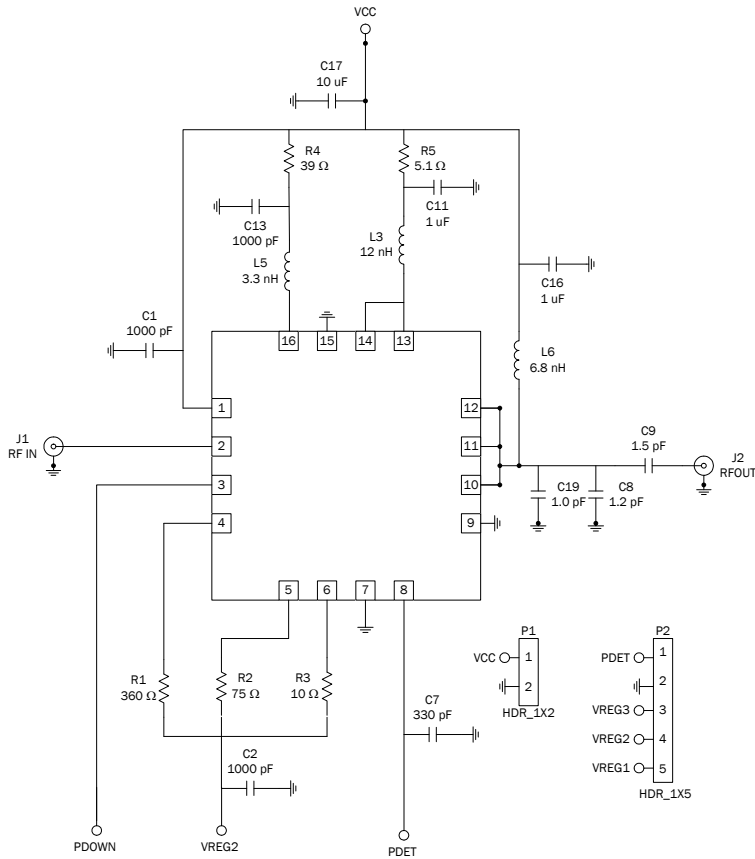



**Evaluation Board Layout (RF5623L)**

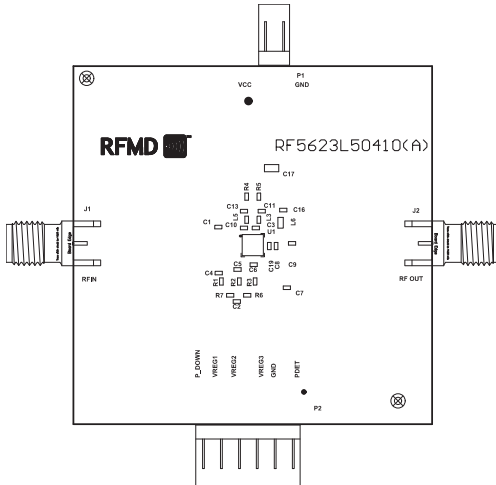

Assembly

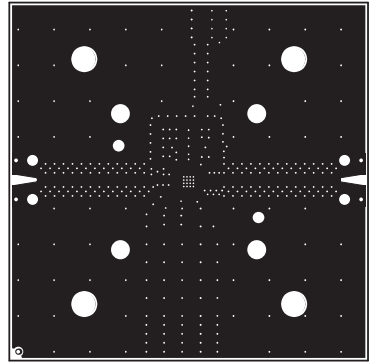

Top

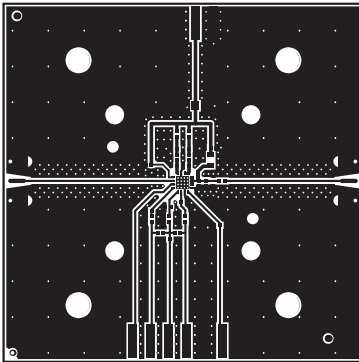

Inner 1

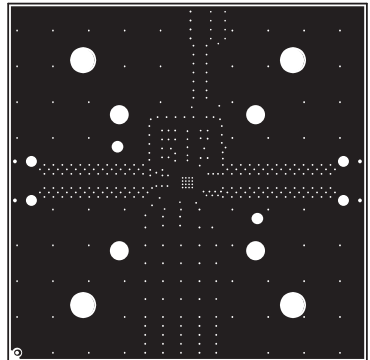

Inner 2

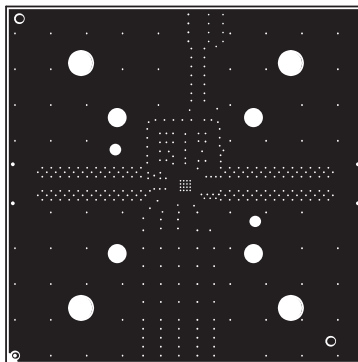

Back

## Evaluation Board Layout (RF5623HL)

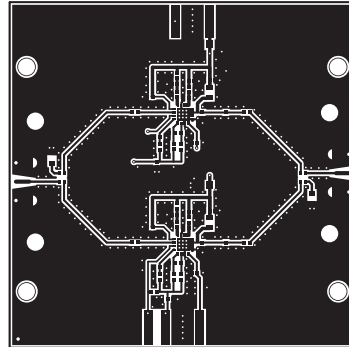
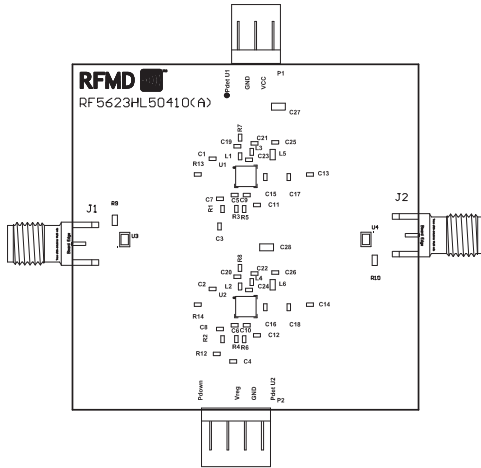

Assembly

Top

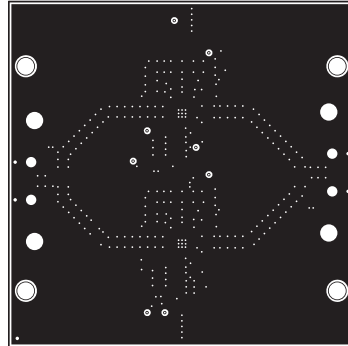
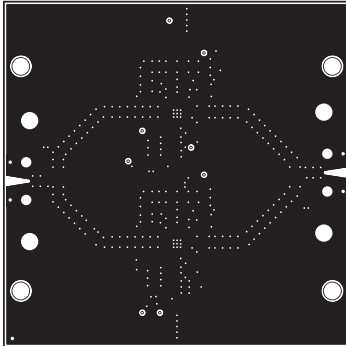

Inner 1

Inner 2

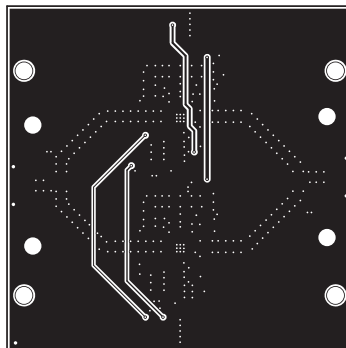

Back

**Evaluation Board Layout (RF5623HH)**

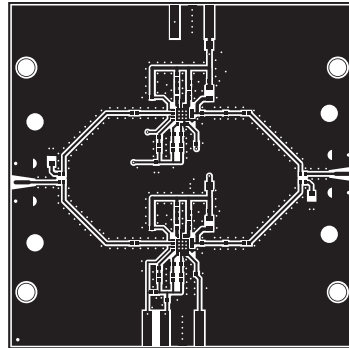
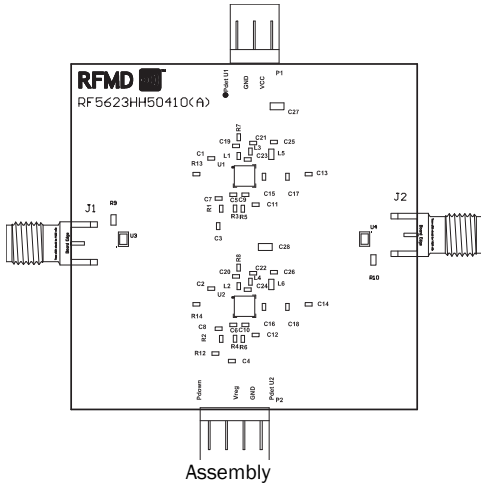

Top

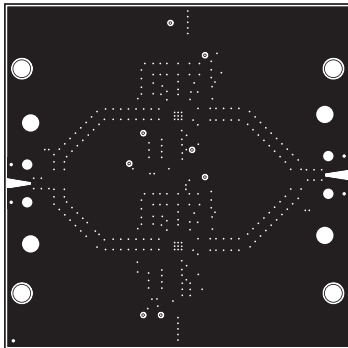

Inner 1

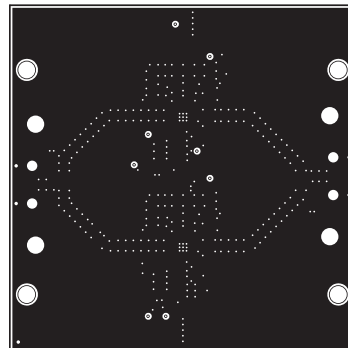

Inner 2

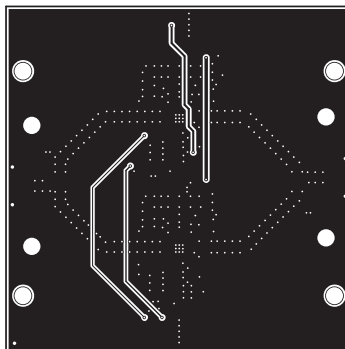

Back

## Evaluation Board Layout (RF5623H)

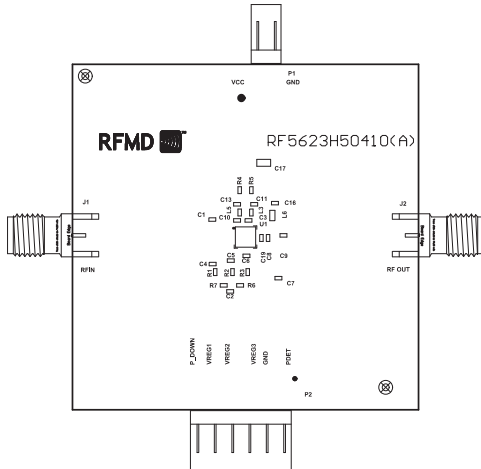

Assembly

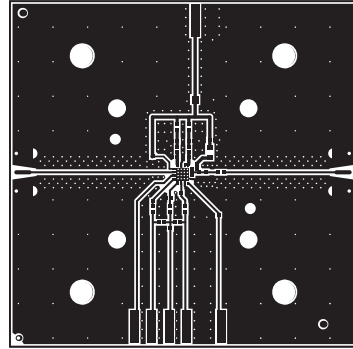

Top

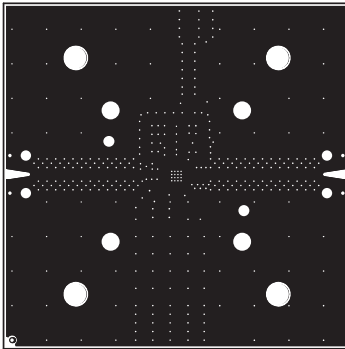

Inner 1

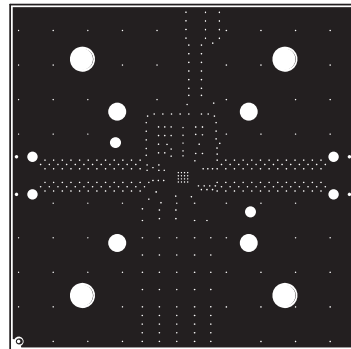

Inner 2

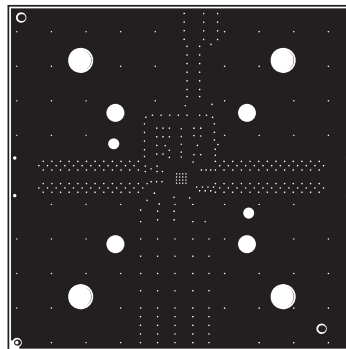

Back

EVM(%) vs. Pout(dBm)  
-40° C  
Vcc=5Vdc Vreg=2.85Vdc

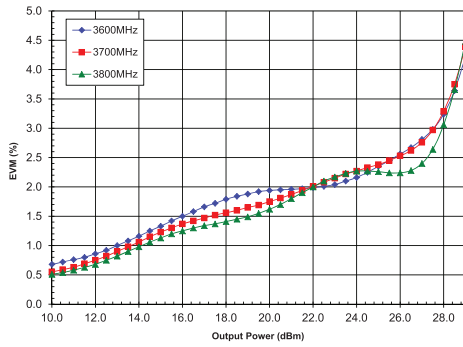

Icc(A) vs. Pout(dBm)  
-40° C  
Vcc=5Vdc Vreg=2.85Vdc

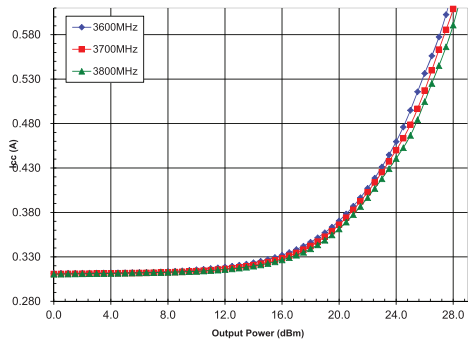

EVM(%) vs. Pout(dBm)  
25° C  
Vcc=5Vdc Vreg=2.85Vdc

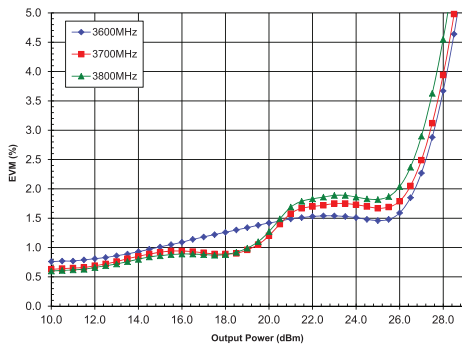

Icc(A) vs. Pout(dBm)  
25° C  
Vcc=5Vdc Vreg=2.85Vdc

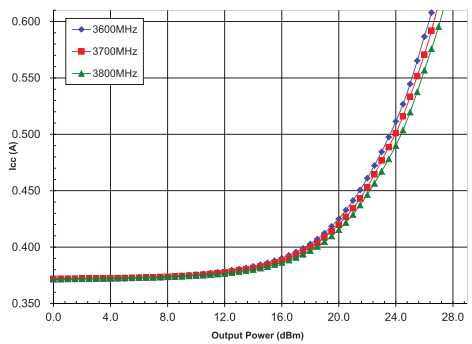

EVM(%) vs. Pout(dBm)  
85° C  
Vcc=5Vdc Vreg=2.85Vdc

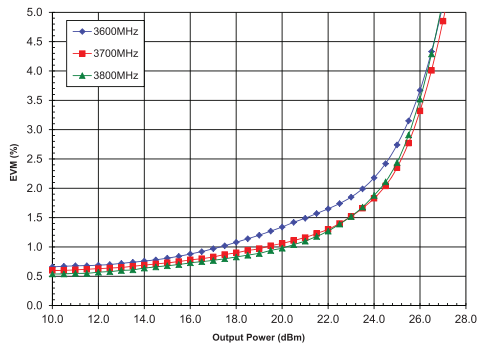

Icc(A) vs. Pout(dBm)  
85° C  
Vcc=5Vdc Vreg=2.85Vdc

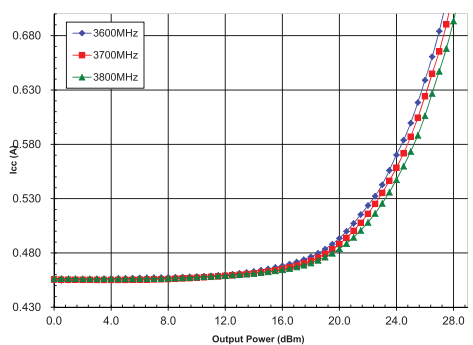

Gain(dB) vs. Pout(dBm)  
-40° C  
Vcc=5Vdc Vreg=2.85Vdc

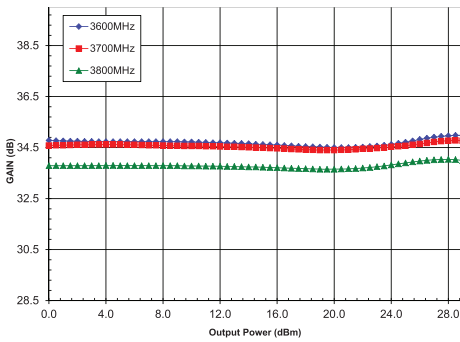

Power Detect (V) vs. Pout(dBm)  
-40° C  
Vcc=5Vdc Vreg=2.85Vdc

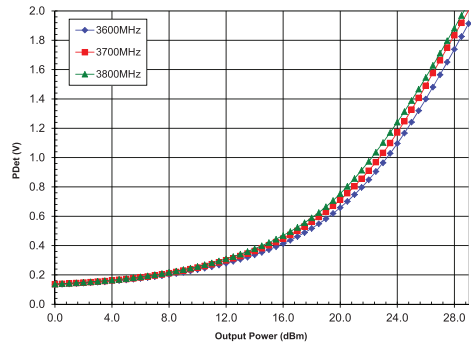

Gain(dB) vs. Pout(dBm)  
25° C  
Vcc=5Vdc Vreg=2.85Vdc

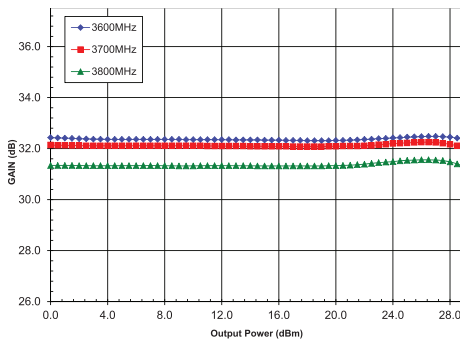

Power Detect (V) vs. Pout(dBm)  
25° C  
Vcc=5Vdc Vreg=2.85Vdc

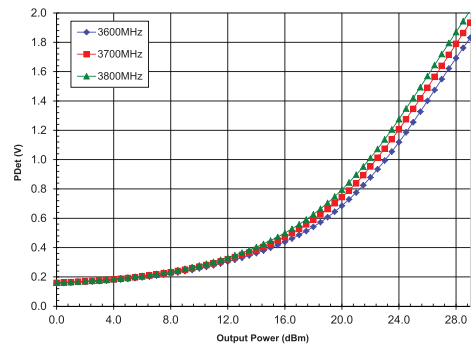

Gain(dB) vs. Pout(dBm)  
25° C  
Vcc=5Vdc Vreg=2.85Vdc

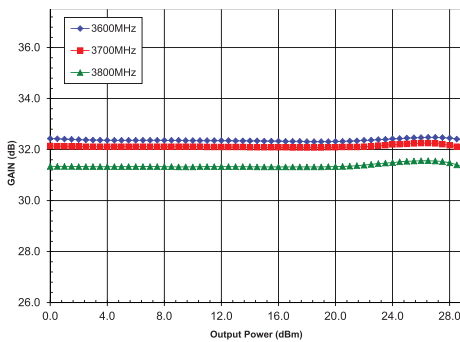

Power Detect (V) vs. Pout(dBm)  
85° C  
Vcc=5Vdc Vreg=2.85Vdc

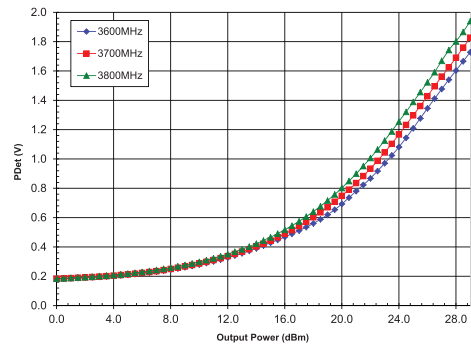

**EVM(%) vs. Pout(dBm)**  
-40° C  
Vcc=5Vdc Vreg=2.85Vdc

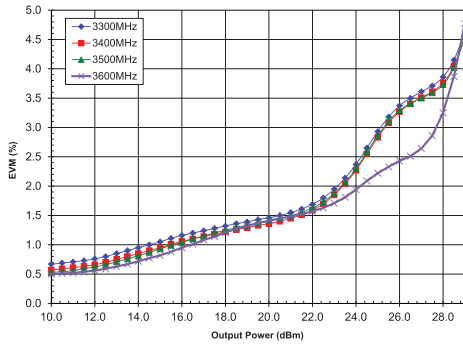

**Icc(A) vs. Pout(dBm)**  
-40° C  
Vcc=5Vdc Vreg=2.85Vdc

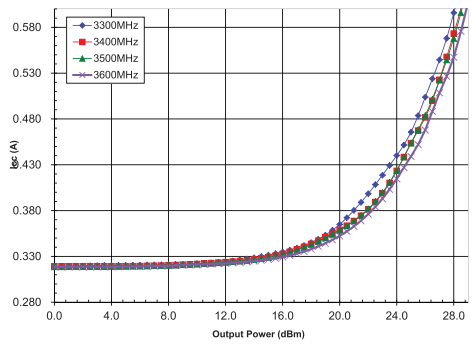

**EVM(%) vs. Pout(dBm)**  
25° C  
Vcc=5Vdc Vreg=2.85Vdc

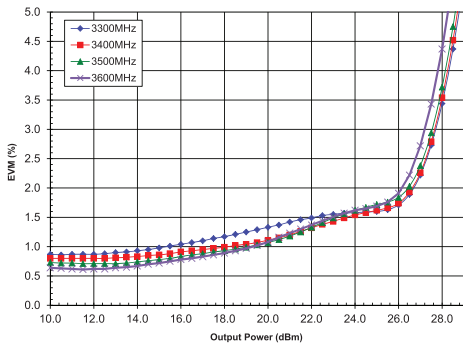

**Icc(A) vs. Pout(dBm)**  
25° C  
Vcc=5Vdc Vreg=2.85Vdc

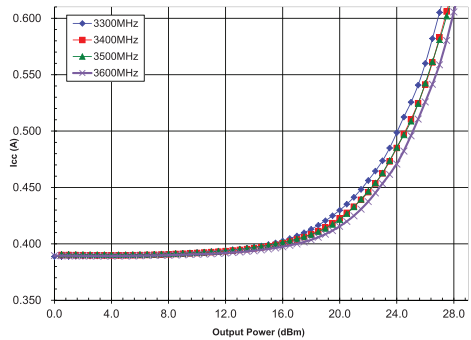

**EVM(%) vs. Pout(dBm)**  
85° C  
Vcc=5Vdc Vreg=2.85Vdc

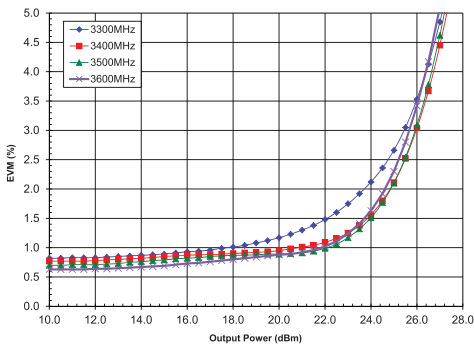

**Icc(A) vs. Pout(dBm)**  
85° C  
Vcc=5Vdc Vreg=2.85Vdc

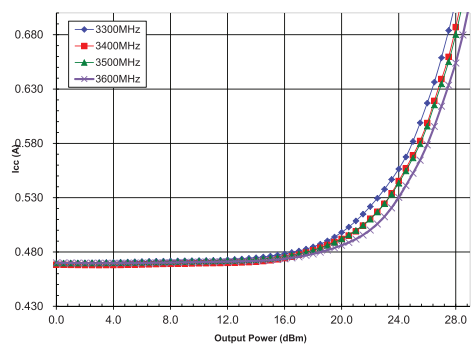

Gain(dB) vs. Pout(dBm)  
-40° C  
Vcc=5Vdc Vreg=2.85Vdc

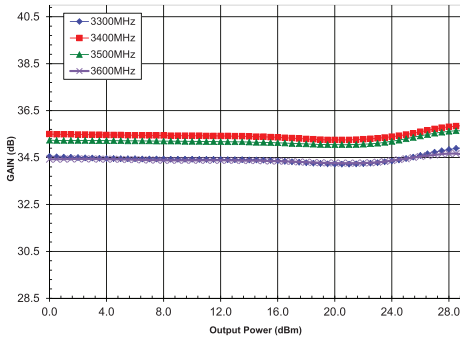

Power Detect (V) vs. Pout(dBm)  
-40° C  
Vcc=5Vdc Vreg=2.85Vdc

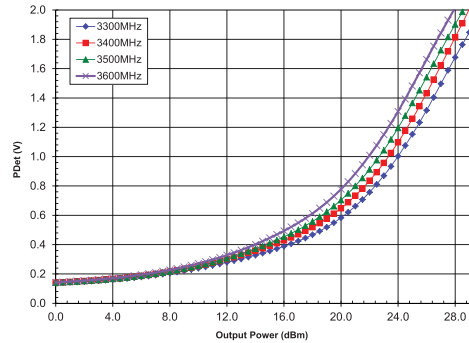

Gain(dB) vs. Pout(dBm)  
25° C  
Vcc=5Vdc Vreg=2.85Vdc

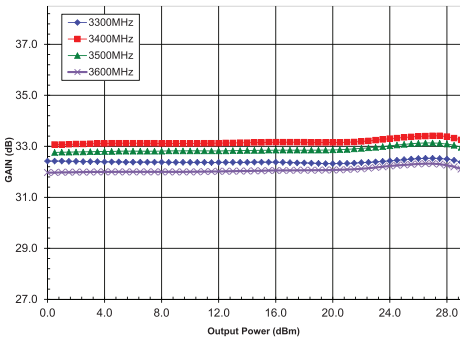

Power Detect (V) vs. Pout(dBm)  
25° C  
Vcc=5Vdc Vreg=2.85Vdc

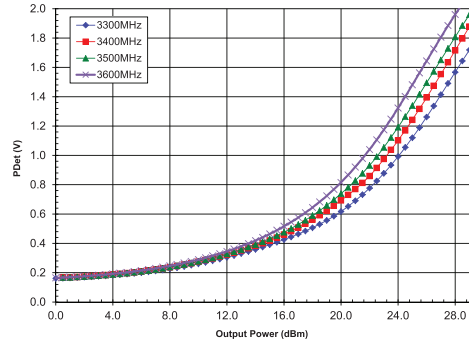

Gain(dB) vs. Pout(dBm)  
85° C  
Vcc=5Vdc Vreg=2.85Vdc

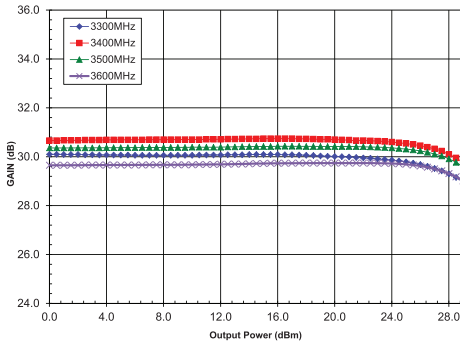

Power Detect (V) vs. Pout(dBm)  
85° C  
Vcc=5Vdc Vreg=2.85Vdc

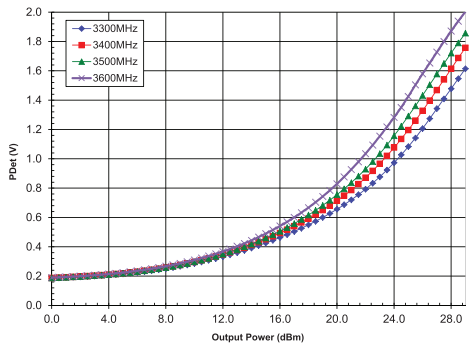



**Ordering Information**

Ordering Code	Description
RF5623	5.0V, 3.3GHz to 3.8GHz Linear Power Amplifier
RF5623SQ	Standard 25 piece bag
RF5623SR	Standard 100 piece reel
RF5623TR	Standard 2500 piece reel
RF5623L50PCBA-410	3.3GHz to 3.6GHz Fully Assembled PCB
RF5623H50PCBA-410	3.6GHz to 3.8GHz Fully Assembled PCB
RF5623HL50PCBA-410	3.3GHz to 3.6GHz Balanced Fully Assembled PCB
RF5623HH50PCBA-410	3.6GHz to 3.8GHz Balanced Fully Assembled PCB

