



2EZ6.8~2EZ51

SILICON ZENER DIODES

VOLTAGE 6.8 to 51 Volts

POWER 2.0 Watts

DO-15

Unit: inch(mm)

FEATURES

- Low profile package
- Built-in strain relief
- Low inductance
- Plastic package has Underwriters Laboratory Flammability Classification 94V-O
- High temperature soldering : 260°C /10 seconds at terminals
- Lead free in comply with EU RoHS 2002/95/EC directives

MECHANICAL DATA

- Case: JEDEC DO-15, Molded plastic over passivated junction
- Terminals: Solder plated, solderable per MIL-STD-750, Method 2026
- Polarity: Color band denotes positive end (cathode)
- Standard packing: 52mm tape
- Weight: 0.014 ounce, 0.0397 gram

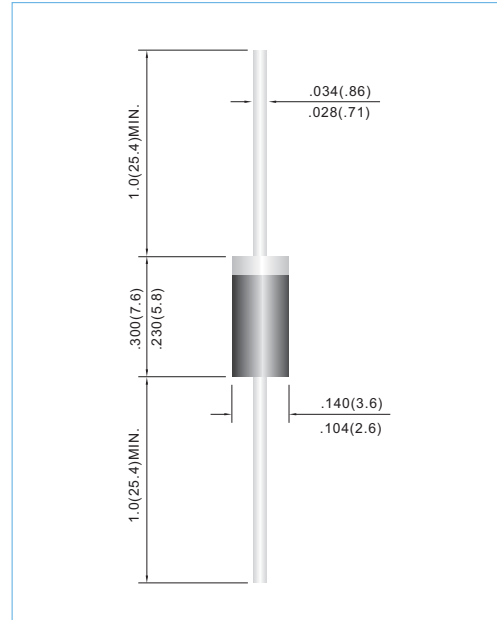

MAXIMUM RATINGS AND ELECTRICAL CHARACTERISTICS

Ratings at 25°C ambient temperature unless otherwise specified.

Parameter	Symbol	Value	Unit
Max Steady State Power Dissipation @ $T_L \leq 80^\circ\text{C}$ (Note A) Derate above $T_A = 25^\circ\text{C}$	P_D	2	Watts
Peak Forward Surge Current 8.3ms single half sine-wave soperimposed on rated load (JEDEC mehod)	I_{FSM}	15	Amps
Thermal resistance Junction to Ambient Junction to Lead	$R_{\theta JA}$ $R_{\theta JL}$	60 32	$^\circ\text{C/W}$
Operating Junction and Storage Temperature Range	T_J, T_{STG}	-55 to + 150	$^\circ\text{C}$

NOTES:

A.Mounted on infinite heat sink with L=2mm

B.Measured on 8.3ms, and single half sine-wave or equivalent square wave ,duty cycle=4 pulses per minute maximum



2EZ6.8~2EZ51

Part Number	Nominal Zener Voltage			Maximum Zener Impedance				Leakage Current		Marking Code
	V _Z @ I _{ZT}			Z _{ZT} @ I _{ZT}		Z _{ZK} @ I _{ZK}		I _R @ V _R		
	Nom. V	Min. V	Max. V	Ω	mA	Ω	mA	uA	V	
2.0 Watt ZENER										
2EZ6.8	6.8	6.46	7.14	2	73.5	700	1	5	4	2EZ6.8
2EZ7.5	7.5	7.13	7.88	2	66.5	700	0.5	5	5	2EZ7.5
2EZ8.2	8.2	7.79	8.61	2	61	700	0.5	5	6	2EZ8.2
2EZ8.7	8.7	8.27	9.14	2	58	700	0.5	4	6.6	2EZ8.7
2EZ9.1	9.1	8.65	9.56	3	55	700	0.5	3	7	2EZ9.1
2EZ10	10	9.5	10.5	4	50	700	0.25	3	7.6	2EZ10
2EZ11	11	10.45	11.55	4	45.5	700	0.25	1	8.4	2EZ11
2EZ12	12	11.4	12.6	5	41.5	700	0.25	1	9.1	2EZ12
2EZ13	13	12.35	13.65	5	38.5	700	0.25	0.5	9.9	2EZ13
2EZ14	14	13.3	14.7	6	35.7	700	0.25	0.5	10.6	2EZ14
2EZ15	15	14.25	15.75	7	33.4	700	0.25	0.5	11.4	2EZ15
2EZ16	16	15.2	16.8	8	31.2	700	0.25	0.5	12.2	2EZ16
2EZ17	17	16.15	17.85	9	29.4	750	0.25	0.5	13	2EZ17
2EZ18	18	17.1	18.9	10	27.8	750	0.25	0.5	13.7	2EZ18
2EZ19	19	18.05	19.95	11	26.3	750	0.25	0.5	14.4	2EZ19
2EZ20	20	19	21	11	25	750	0.25	0.5	15.2	2EZ20
2EZ22	22	20.9	23.1	12	22.8	750	0.25	0.5	16.7	2EZ22
2EZ24	24	22.8	25.2	13	20.8	750	0.25	0.5	18.2	2EZ24
2EZ25	25	23.75	26.25	14	20	750	0.25	0.5	19	2EZ25
2EZ27	27	25.65	28.35	18	18.5	750	0.25	0.5	20.6	2EZ27
2EZ28	28	26.6	29.4	18	17	750	0.25	0.5	21.3	2EZ28
2EZ30	30	28.5	31.5	20	16.6	1000	0.25	0.5	22.5	2EZ30
2EZ33	33	31.35	34.65	23	15.1	1000	0.25	0.5	25.1	2EZ33
2EZ36	36	34.2	37.8	25	13.9	1000	0.25	0.5	27.4	2EZ36
2EZ39	39	37.05	40.95	30	12.8	1000	0.25	0.5	29.7	2EZ39
2EZ43	43	40.85	45.15	35	11.6	1500	0.25	0.5	32.7	2EZ43
2EZ47	47	44.65	49.35	40	10.6	1500	0.25	0.5	35.8	2EZ47
2EZ51	51	48.45	53.55	48	9.8	1500	0.25	0.5	38.8	2EZ51



2EZ6.8~2EZ51

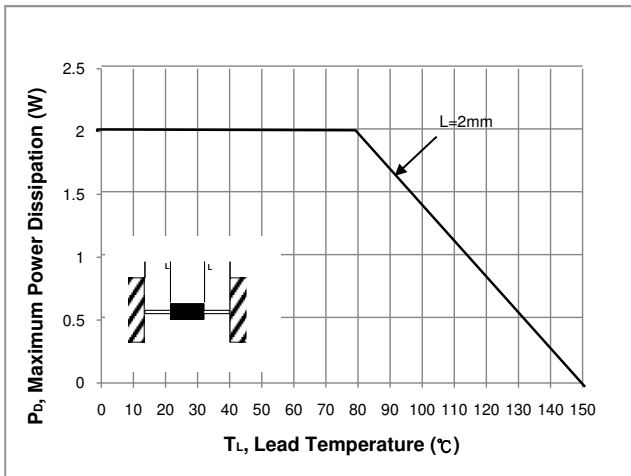

Fig.1 Power Temperature Derating Curve

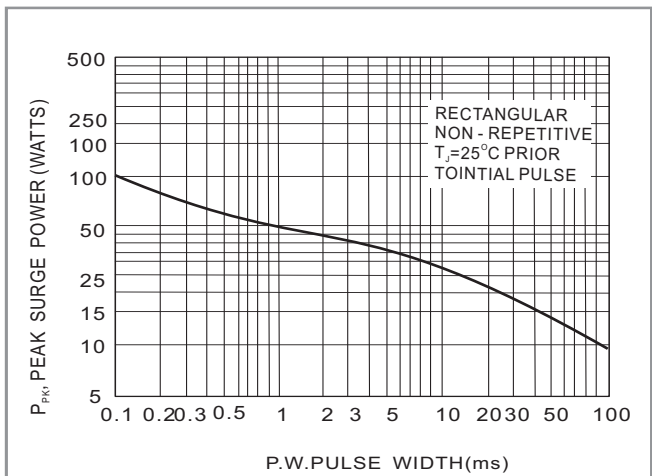

FIGURE 2. MAXIMUM SURGE POWER

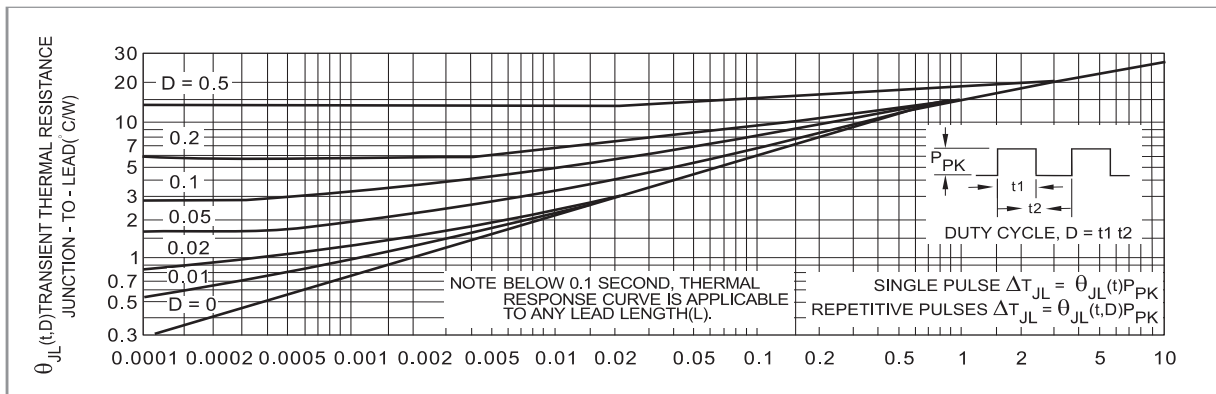

FIGURE 3. TYPICAL THERMAL RESPONSE,

APPLICATION NOTE:

Since the actual voltage available from a given zener diode is temperature dependent, it is necessary to determine junction temperature under any set of operating conditions in order to calculate its value. The following procedure is recommended:

Lead Temperature, T_L , should be determined from:

$$T_L = \theta_{L-A} P_D + T_A$$

θ_{L-A} is the lead-to-ambient thermal resistance ($^{\circ}\text{C}/\text{W}$) and P_D is the power dissipation. The value for θ_{L-A} will vary and depends on the device mounting method. θ_{L-A} is generally $30\text{-}40\text{ }^{\circ}\text{C}/\text{W}$ for the various clips and tie points in common use and for printed circuit board wiring.

The temperature of the lead can also be measured using a thermocouple placed on the lead as close as possible to the tie point.

The thermal mass connected to the tie point is normally large enough so that it will not significantly respond to heat surges generated in the diode as a result of pulsed operation once steady-state conditions are achieved. Using the measured value of T_L , the junction temperature may be determined by:

$$T_J = T_L + \Delta T_{JL}$$

ΔT_{JL} is the increase in junction temperature above the lead temperature and may be found from Figure 3 for a train of power pulses or from Figure 10 for dc power.

$$\Delta T_{JL} = \theta_{JL} P_D$$

For worst-case design, using expected limits of I_Z , limits of P_D and the extremes of T_J (ΔT_J) may be estimated. Changes in voltage, V_Z , can then be found from:

$$\Delta V = \alpha_V V_Z \Delta T_J$$

α_V V_Z , the zener voltage temperature coefficient, is found from Figures 5 and 6.

Under high power-pulse operation, the zener voltage will vary with time and may also be affected significantly by the zener resistance. For best regulation, keep current excursions as low as possible.

Data of Figure 3 should not be used to compute surge capability. Surge limitations are given in Figure 2. They are lower than would be expected by considering only junction temperature, as current crowding effects cause temperatures to be extremely high in small spots resulting in device degradation should the limits of Figure 2 be exceeded.



2EZ6.8~2EZ51

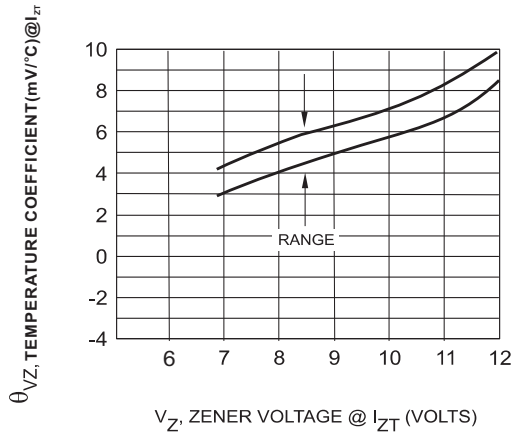

FIGURE 4. UNITS 6.8 TO 12 VOLTS

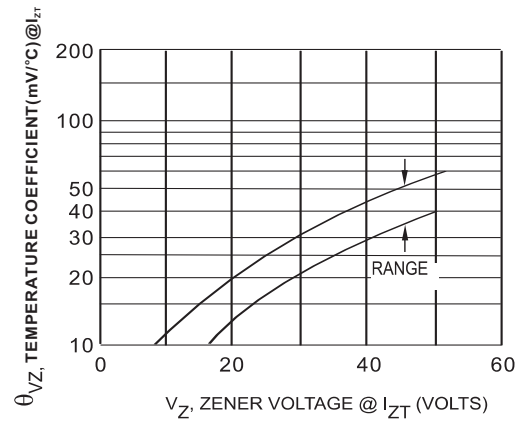

FIGURE 5. UNITS 10 TO 51 VOLTS

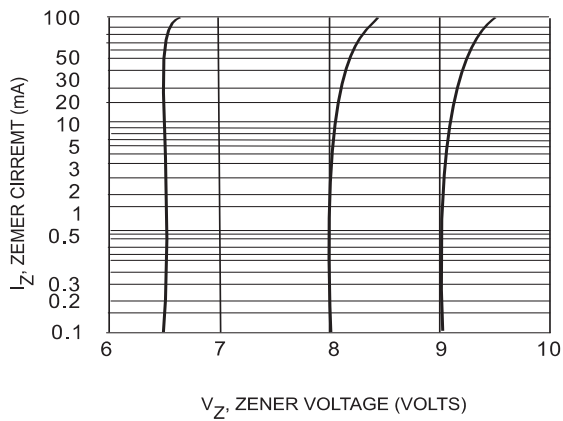

FIGURE 6. $V_Z=6.8$ THRU 10 VOLTS

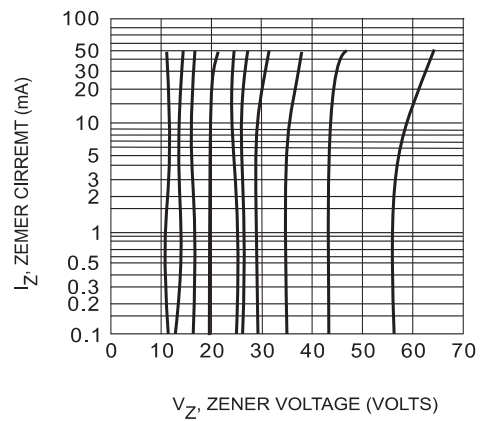

FIGURE 7. $V_Z=12$ THRU 51 VOLTS

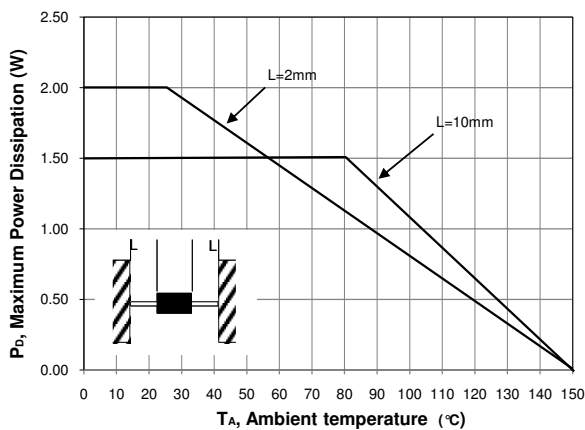

FIGURE 8. TYPICAL THERMAL RESISTANCE



2EZ6.8~2EZ51

For example :

RB500V-40_R2_00001



Packing Code XX				Version Code XXXXX		
Packing type	1 st Code	Packing size code	2 nd Code	HF or RoHS	1 st Code	2 nd ~5 th Code
T/B	A	N/A	0	HF	0	serial number
T/R	R	7"	1	RoHS	1	serial number
B/P	B	13"	2			
T/P	T	26mm	X			
TRR	S	52mm	Y			
TRL	L	PBCU	U			
FORMING	F	PBCD	D			

Part No_packing code_Version

2EZ6.8_AY_00001

2EZ6.8_AY_10001

2EZ6.8_B0_00001

2EZ6.8_B0_10001

2EZ6.8_R2_00001

2EZ6.8_R2_10001