

GMZJ2.0~GMZJ56

SURFACE MOUNT ZENER DIODES

VOLTAGE 2.0 to 56 Volts **POWER** 500 mWatts

MICRO-MELF Unit : inch(mm)

FEATURES

- Planar Die construction
- 500mW Power Dissipation
- Ideally Suited for Automated Assembly Processes
- Lead free in comply with EU RoHS 2002/95/EC directives

MECHANICAL DATA

- Case: Molded Glass MICRO-MELF
- Terminals: Solderable per MIL-STD-750, Method 2026
- Approx. Weight: 0.01 grams.
- Mounting Position: Any
- Polarity : Color band denotes cathode end
- Packing information
T/R - 2.5K per 7" plastic Reel

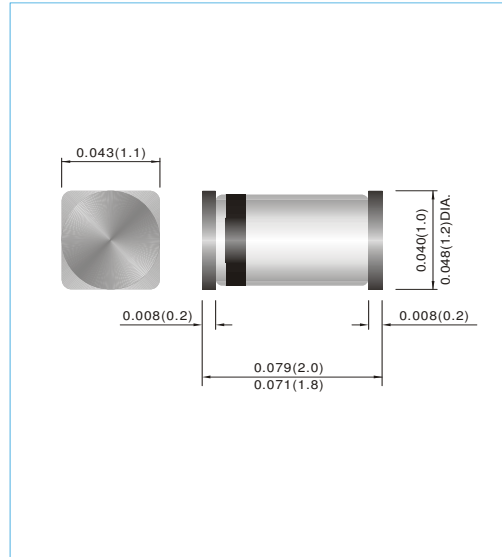
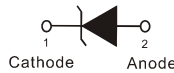
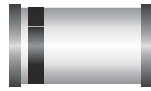

MAXIMUM RATINGS AND ELECTRICAL CHARACTERISTICS

Parameter	Symbol	Value	Units
Power Dissipation at T _A = 25°C	P _{TOT}	500	mW
Operating Junction Temperature Range	T _J	175	°C
Storage Temperature Range	T _{STG}	-65 to + 175	°C

Valid provided that leads at a distance of 10mm from case are kept at ambient temperature.

Parameter	Symbol	Min.	Typ.	Max.	Units
Thermal Resistance Junction to Ambient Air	R _{θJA}	--	--	0.3	°C/mW
Forward Voltage at I _F = 100mA	V _F	--	--	1	V

Valid provided that leads at a distance of 10mm from case are kept at ambient temperature.

GMZJ2.0~GMZJ56

Part Number	Nominal Zener Voltage			Max. Zener Impedance				Max Reverse Leakage Current	
	V _Z @ I _{ZT}			Z _{ZT} @ I _{ZT}		Z _{ZK} @ I _{ZK}		I _R @ V _R	
	Nom. V	Min. V	Max. V	Ω	mA	Ω	mA	μA	V
500 mW Zener Diodes									
GMZJ 2.0A	2	1.88	2.1	100	5	1000	0.5	120	0.5
GMZJ 2.0B	2	2.02	2.2	100	5	1000	0.5	120	0.5
GMZJ 2.2A	2.2	2.12	2.3	100	5	1000	0.5	120	0.7
GMZJ 2.2B	2.2	2.22	2.41	100	5	1000	0.5	120	0.7
GMZJ 2.4A	2.4	2.33	2.52	100	5	1000	0.5	120	1
GMZJ 2.4B	2.4	2.43	2.63	100	5	1000	0.5	120	1
GMZJ 2.7A	2.7	2.54	2.75	110	5	1000	0.5	120	1
GMZJ 2.7B	2.7	2.69	2.91	110	5	1000	0.5	120	1
GMZJ 3.0A	3	2.85	3.07	120	5	1000	0.5	50	1
GMZJ 3.0B	3	3.01	3.22	120	5	1000	0.5	50	1
GMZJ 3.3A	3.3	3.16	3.38	120	5	1000	0.5	20	1
GMZJ 3.3B	3.3	3.32	3.53	120	5	1000	0.5	20	1
GMZJ 3.6A	3.6	3.46	3.69	100	5	1000	1	10	1
GMZJ 3.6B	3.6	3.6	3.84	100	5	1000	1	10	1
GMZJ 3.9A	3.9	3.74	4.01	100	5	1000	1	5	1
GMZJ 3.9B	3.9	3.89	4.16	100	5	1000	1	5	1
GMZJ 4.3A	4.3	4.04	4.29	100	5	1000	1	5	1
GMZJ 4.3B	4.3	4.17	4.43	100	5	1000	1	5	1
GMZJ 4.3C	4.3	4.3	4.57	100	5	1000	1	5	1
GMZJ 4.7A	4.7	4.44	4.68	90	5	900	1	5	1
GMZJ 4.7B	4.7	4.55	4.80	90	5	900	1	5	1
GMZJ 4.7C	4.7	4.68	4.93	90	5	900	1	5	1
GMZJ 5.1A	5.1	4.81	5.07	80	5	800	1	5	1.5
GMZJ 5.1B	5.1	4.94	5.2	80	5	800	1	5	1.5
GMZJ 5.1C	5.1	5.09	5.37	80	5	800	1	5	1.5
GMZJ 5.6A	5.6	5.28	5.55	60	5	500	1	5	2.5
GMZJ 5.6B	5.6	5.45	5.73	60	5	500	1	5	2.5
GMZJ 5.6C	5.6	5.61	5.91	60	5	500	1	5	2.5
GMZJ 6.2A	6.2	5.78	6.09	60	5	300	1	5	3
GMZJ 6.2B	6.2	5.96	6.27	60	5	300	1	5	3
GMZJ 6.2C	6.2	6.12	6.44	60	5	300	1	5	3
GMZJ 6.8A	6.8	6.29	6.63	20	5	150	0.5	2	3.5
GMZJ 6.8B	6.8	6.49	6.83	20	5	150	0.5	2	3.5
GMZJ 6.8C	6.8	6.66	7.01	20	5	150	0.5	2	3.5
GMZJ 7.5A	7.5	6.85	7.22	20	5	120	0.5	0.5	4
GMZJ 7.5B	7.5	7.07	7.45	20	5	120	0.5	0.5	4
GMZJ 7.5C	7.5	7.29	7.67	20	5	120	0.5	0.5	4
GMZJ 8.2A	8.2	7.53	7.92	20	5	120	0.5	0.5	5
GMZJ 8.2B	8.2	7.78	8.19	20	5	120	0.5	0.5	5
GMZJ 8.2C	8.2	8.03	8.45	20	5	120	0.5	0.5	5
GMZJ 9.1A	9.1	8.29	8.73	25	5	120	0.5	0.5	6
GMZJ 9.1B	9.1	8.57	9.01	25	5	120	0.5	0.5	6
GMZJ 9.1C	9.1	8.83	9.3	25	5	120	0.5	0.5	6
GMZJ 10A	10	9.12	9.59	30	5	120	0.5	0.2	7
GMZJ 10B	10	9.41	9.9	30	5	120	0.5	0.2	7
GMZJ 10C	10	9.7	10.2	30	5	120	0.5	0.2	7
GMZJ 10D	10	9.94	10.44	30	5	120	0.5	0.2	7
GMZJ 11A	11	10.18	10.71	30	5	120	0.5	0.2	8
GMZJ 11B	11	10.5	11.05	30	5	120	0.5	0.2	8
GMZJ 11C	11	10.82	11.38	30	5	120	0.5	0.2	8

GMZJ2.0~GMZJ56

Part Number	Nominal Zener Voltage			Max. Zener Impedance				Max Reverse Leakage Current	
	V _Z @ I _{ZT}			Z _{ZT} @ I _{ZT}		Z _{ZK} @ I _{ZK}		I _R @ V _R	
	Nom. V	Min. V	Max. V	Ω	mA	Ω	mA	μA	V
500 mW Zener Diodes									
GMZJ 12A	12	11.13	11.71	30	5	110	0.5	0.2	9
GMZJ 12B	12	11.44	12.03	30	5	110	0.5	0.2	9
GMZJ 12C	12	11.74	12.35	30	5	110	0.5	0.2	9
GMZJ 13A	13	12.11	12.75	35	5	110	0.5	0.2	10
GMZJ 13B	13	12.55	13.21	35	5	110	0.5	0.2	10
GMZJ 13C	13	12.99	13.66	35	5	110	0.5	0.2	10
GMZJ 15A	15	13.44	14.13	40	5	110	0.5	0.2	11
GMZJ 15B	15	13.89	14.62	40	5	110	0.5	0.2	11
GMZJ 15C	15	14.35	15.09	40	5	110	0.5	0.2	11
GMZJ 16A	16	14.8	15.57	40	5	150	0.5	0.2	12
GMZJ 16B	16	15.25	16.04	40	5	150	0.5	0.2	12
GMZJ 16C	16	15.69	16.51	40	5	150	0.5	0.2	12
GMZJ 18A	18	16.22	17.06	45	5	150	0.5	0.2	13
GMZJ 18B	18	16.82	17.7	45	5	150	0.5	0.2	13
GMZJ 18C	18	17.42	18.33	45	5	150	0.5	0.2	13
GMZJ 20A	20	18.02	18.96	55	5	200	0.5	0.2	15
GMZJ 20B	20	18.63	19.59	55	5	200	0.5	0.2	15
GMZJ 20C	20	19.23	20.22	55	5	200	0.5	0.2	15
GMZJ 20D	20	19.72	20.72	55	5	200	0.5	0.2	15
GMZJ 22A	22	20.15	21.2	30	5	200	0.5	0.2	17
GMZJ 22B	22	20.64	21.71	30	5	200	0.5	0.2	17
GMZJ 22C	22	21.08	22.17	30	5	200	0.5	0.2	17
GMZJ 22D	22	21.52	22.63	30	5	200	0.5	0.2	17
GMZJ 24A	24	22.05	23.18	35	5	200	0.5	0.2	19
GMZJ 24B	24	22.61	23.77	35	5	200	0.5	0.2	19
GMZJ 24C	24	23.12	24.31	35	5	200	0.5	0.2	19
GMZJ 24D	24	23.63	24.85	35	5	200	0.5	0.2	19
GMZJ 27A	27	24.26	25.52	45	5	250	0.5	0.2	21
GMZJ 27B	27	24.97	26.26	45	5	250	0.5	0.2	21
GMZJ 27C	27	25.63	26.95	45	5	250	0.5	0.2	21
GMZJ 27D	27	26.29	27.64	45	5	250	0.5	0.2	21
GMZJ 30A	30	26.99	28.39	55	5	250	0.5	0.2	23
GMZJ 30B	30	27.7	29.13	55	5	250	0.5	0.2	23
GMZJ 30C	30	28.36	29.82	55	5	250	0.5	0.2	23
GMZJ 30D	30	29.02	30.51	55	5	250	0.5	0.2	23
GMZJ 33A	33	29.68	31.22	65	5	250	0.5	0.2	25
GMZJ 33B	33	30.32	31.88	65	5	250	0.5	0.2	25
GMZJ 33C	33	30.9	32.5	65	5	250	0.5	0.2	25
GMZJ 33D	33	31.49	33.11	65	5	250	0.5	0.2	25
GMZJ 36A	36	32.14	33.79	75	5	250	0.5	0.2	27
GMZJ 36B	36	32.79	34.49	75	5	250	0.5	0.2	27
GMZJ 36C	36	33.4	35.13	75	5	250	0.5	0.2	27
GMZJ 36D	36	34.01	35.77	75	5	250	0.5	0.2	27
GMZJ 39A	39	34.68	36.47	85	5	250	0.5	0.2	30
GMZJ 39B	39	35.36	37.19	85	5	250	0.5	0.2	30
GMZJ 39C	39	36	37.85	85	5	250	0.5	0.2	30
GMZJ 39D	39	36.63	38.52	85	5	250	0.5	0.2	30
GMZJ 43	43	40	45	90	5	-	-	0.2	33
GMZJ 47	47	44	49	90	5	-	-	0.2	36
GMZJ 51	51	48	54	110	5	-	-	0.2	39
GMZJ 56	56	53	60	110	5	-	-	0.2	43

Typical Characteristics ($T_{amb} = 25\text{ }^{\circ}\text{C}$ unless otherwise specified)

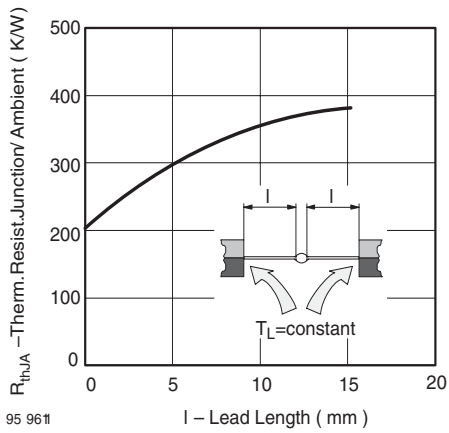

Fig. 1 Thermal Resistance vs. Lead Length

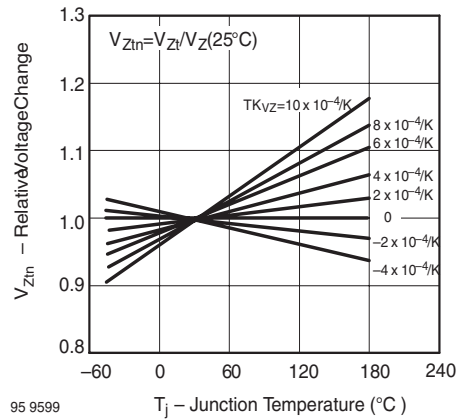

Fig. 4 Typical Change of Working Voltage vs. Junction Temperature

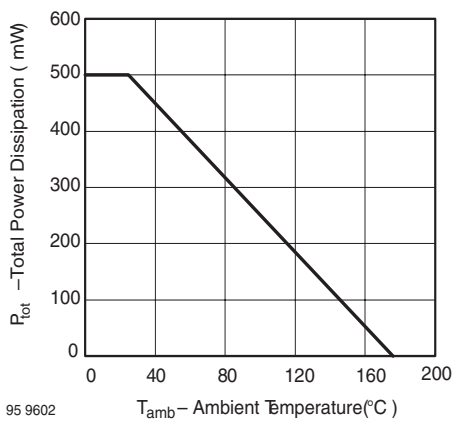

Fig. 2 Total Power Dissipation vs. Ambient Temperature

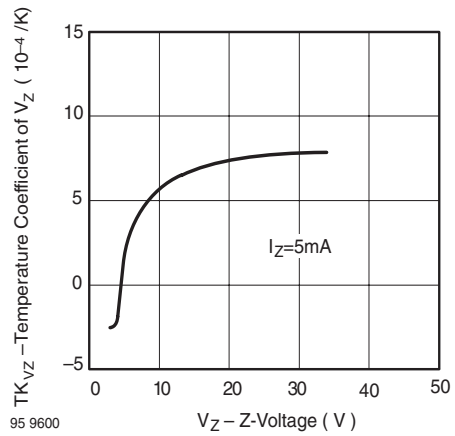

Fig. 5 Temperature Coefficient of V_Z vs. Z-Voltage

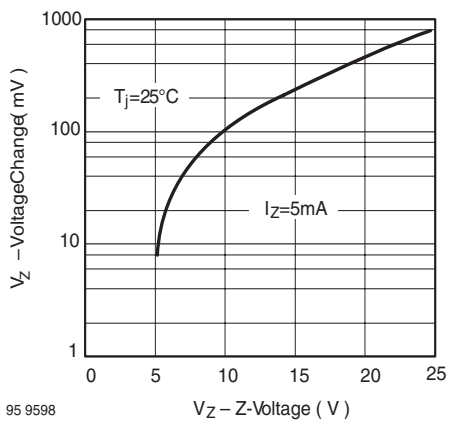

Fig. 3 Typical Change of Working Voltage under Operating Conditions at $T_{amb}=25\text{ }^{\circ}\text{C}$

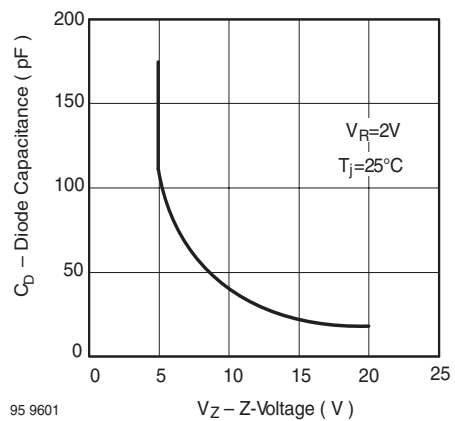

Fig. 6 Diode Capacitance vs. Z-Voltage

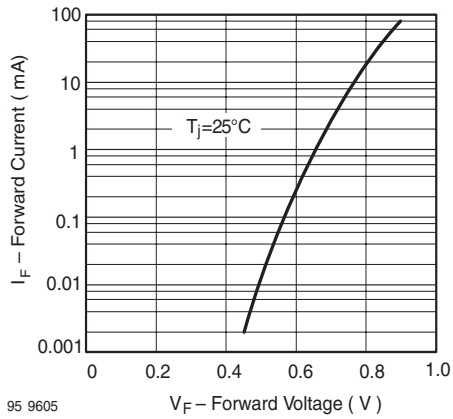

Fig. 7 Forward Current vs. Forward Voltage

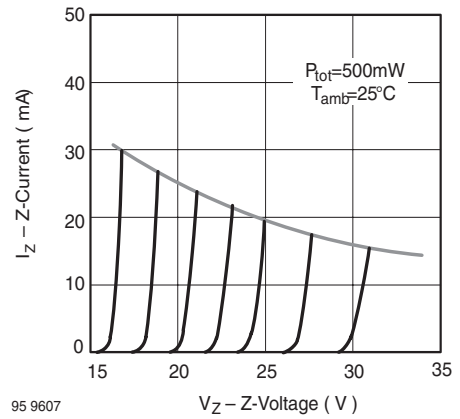

Fig. 9 Z-Current vs. Z-Voltage

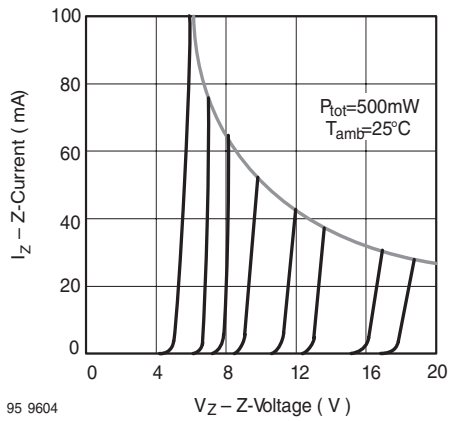

Fig. 8 Z-Current vs. Z-Voltage

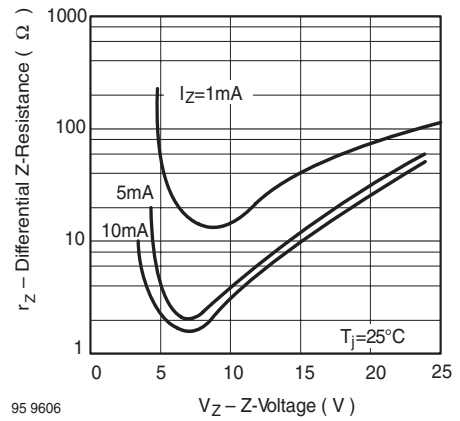

Fig. 10 Differential Z-Resistance vs. Z-Voltage

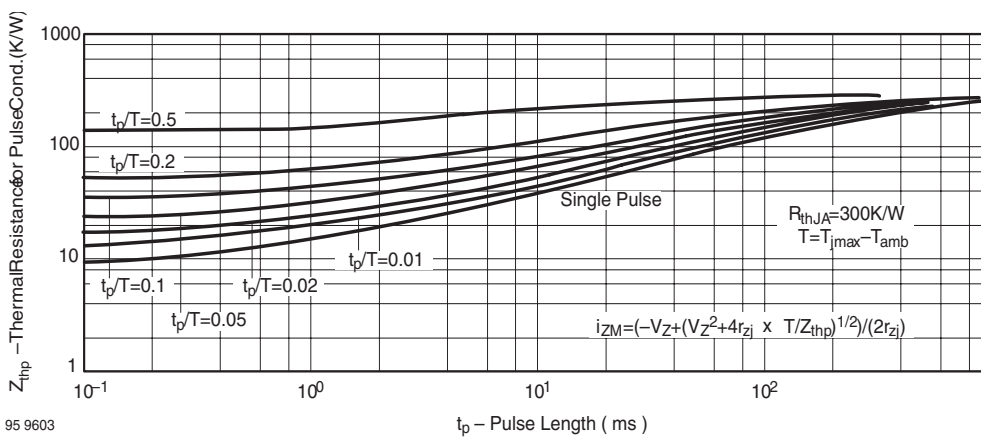
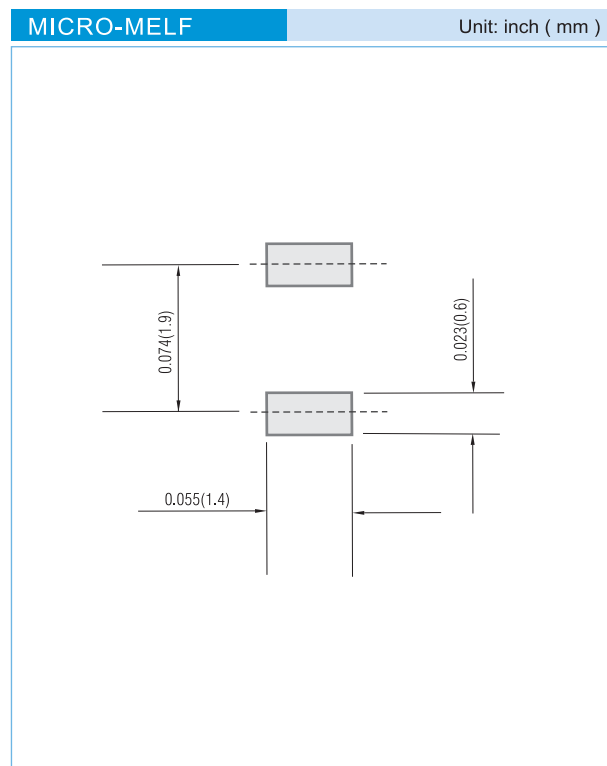

Fig. 11 Thermal Response

GMZJ2.0~GMZJ56

MOUNTING PAD LAYOUT



ORDER INFORMATION

- Packing information

T/R - 10K per 13" plastic Reel

T/R - 2.5K per 7" plastic Reel

LEGAL STATEMENT

Copyright PanJit International, Inc 2012

The information presented in this document is believed to be accurate and reliable. The specifications and information herein are subject to change without notice. Pan Jit makes no warranty, representation or guarantee regarding the suitability of its products for any particular purpose. Pan Jit products are not authorized for use in life support devices or systems. Pan Jit does not convey any license under its patent rights or rights of others.

GMZJ2.0~GMZJ56

For example :

RB500V-40_R2_00001

Part No.

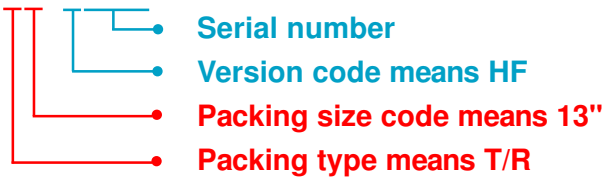

Packing Code XX				Version Code XXXXX		
Packing type	1 st Code	Packing size code	2 nd Code	HF or RoHS	1 st Code	2 nd ~5 th Code
T/B	A	N/A	0	HF	0	serial number
T/R	R	7"	1	RoHS	1	serial number
B/P	B	13"	2			
T/P	T	26mm	X			
TRR	S	52mm	Y			
TRL	L	PBCU	U			
FORMING	F	PBCD	D			

Part No_packing code_Version

GMZJ2.0A_R1_10001

GMZJ2.0A_R2_10001