



UF200 ~ UF2010

ULTRAFAST SWITCHING RECTIFIER

VOLTAGE 50 to 1000 Volts **CURRENT** 2.0 Amperes

DO-15 Unit: inch(mm)

FEATURES

- Plastic package has Underwriters Laboratory Flammability Classification 94V-O utilizing Flame Retardant Epoxy Molding Compound
- Exceeds environmental standards of MIL-S-19500/228.
- Ultra Fast switching for high efficiency.
- In compliance with EU RoHS 2002/95/EC directives

MECHANICAL DATA

- Case: Molded plastic, DO-15
- Terminals: Axial leads, solderable per MIL-STD-750, Method 2026
- Polarity: Band denotes cathode
- Mounting Position: Any
- Weight: 0.014 ounce, 0.397 gram

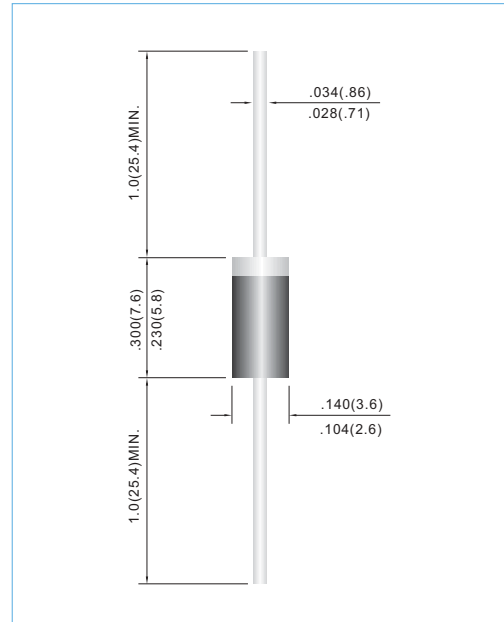

MAXIMUM RATINGS AND ELECTRICAL CHARACTERISTICS

Ratings at 25°C ambient temperature unless otherwise specified. Resistive or inductive load, 60Hz.

PARAMETER	SYMBOL	UF200	UF201	UF202	UF204	UF206	UF208	UF2010	UNITS
Maximum Recurrent Peak Reverse Voltage	V_{RRM}	50	100	200	400	600	800	1000	V
Maximum RMS Voltage	V_{RMS}	35	70	140	280	420	560	700	V
Maximum DC Blocking Voltage	V_{DC}	50	100	200	400	600	800	1000	V
Maximum Average Forward Current at $T_A=55^\circ\text{C}$	$I_{F(AV)}$	2.0							A
Peak Forward Surge Current : 8.3ms single half sine-wave superimposed on rated load (JEDEC method)	I_{FSM}	60							A
Maximum Forward Voltage at 2.0A	V_F	1.0		1.3		1.7			V
Maximum DC Reverse Current at $T_J=25^\circ\text{C}$ Rated DC Blocking Voltage $T_J=100^\circ\text{C}$	I_R				10.0				μA
					500				
Typical Junction capacitance (Note 1)	C_J				35				pF
Typical Thermal Resistance (Note 2)	$R_{\theta JA}$				40				$^\circ\text{C} / \text{W}$
Maximum Reverse Recovery Time (Note 3)	t_{rr}	50			75				ns
Operating Junction and Storage Temperature Range	T_J, T_{STG}	-55 to +150							$^\circ\text{C}$

NOTES:

1. Measured at 1 MHz and applied reverse voltage of 4.0 VDC.
2. Thermal Resistance from Junction to Ambient and from Junction to lead length 0.375"(9.5mm) P.C.B. mounted.
3. Reverse Recovery Time $I_F=.5\text{A}$, $I_R=1\text{A}$, $I_{rr}=.25\text{A}$



UF200 ~ UF2010

RATING AND CHARACTERISTIC CURVES

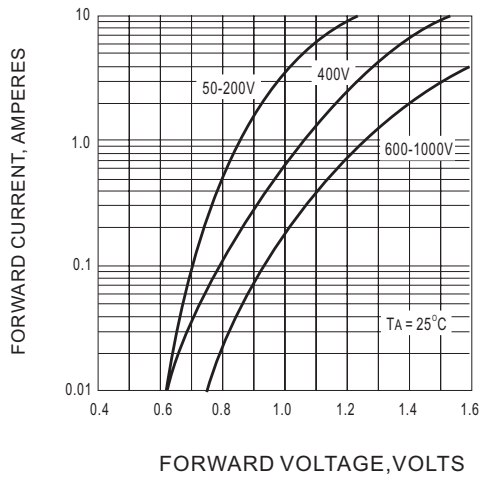

Fig.1 FORWARD CHARACTERISTICS

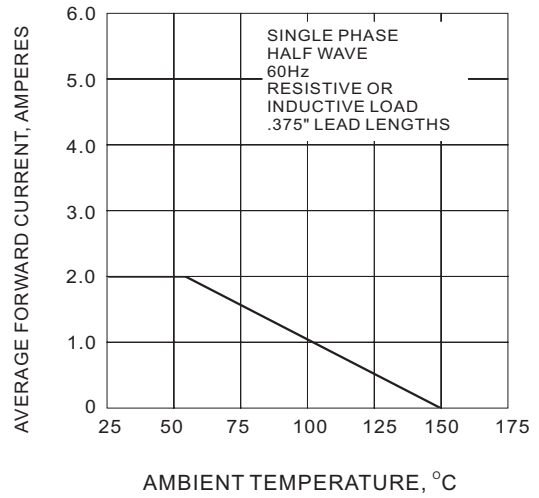

Fig.2 FORWARD CURRENT DERATING CURVE

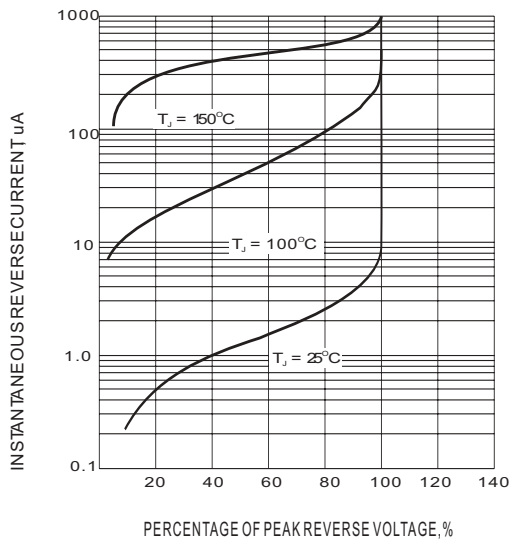

Fig.3 TYPICAL REVERSE CHARACTERISTIC

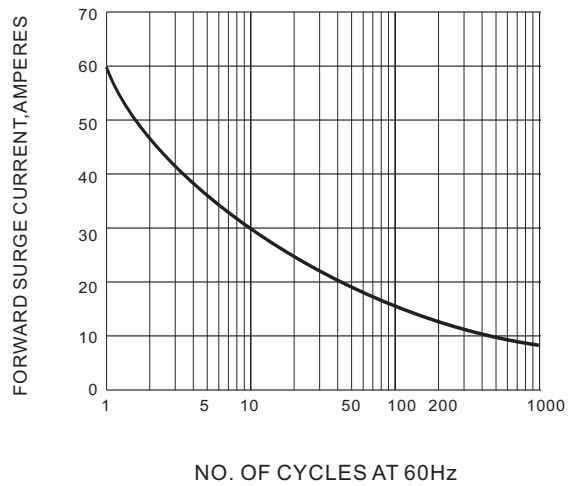

Fig.4 PEAK FORWARD SURGE CURRENT