

JZV SERIES

105°C Low Impedance, High Temperature Reflow Soldering.

◆FEATURES

- Load Life : 105°C 2000 hours.
- High Temperature reflow soldering is available.
- Available for high density mounting.
- Low impedance at 100kHz with selected materials.
- RoHS compliance.



◆SPECIFICATIONS

Items	Characteristics																												
Category Temperature Range	-55~+105°C																												
Rated Voltage Range	6.3~35V.DC																												
Capacitance Tolerance	±20% (20°C, 120Hz)																												
Leakage Current(MAX)	I=0.01CV or 3μA whichever is greater. (After 2 minutes application of rated voltage) I=(μA) Leakage Current      C=(μF) Rated Capacitance      V=(V) Rated Voltage																												
(tanδ) Dissipation Factor(MAX)	<table border="1"> <tr> <td>Rated Voltage</td> <td>6.3</td> <td>10</td> <td>16</td> <td>25</td> <td>35</td> <td>(20°C, 120Hz)</td> </tr> <tr> <td>tanδ</td> <td>0.26</td> <td>0.19</td> <td>0.16</td> <td>0.14</td> <td>0.12</td> <td></td> </tr> </table>	Rated Voltage	6.3	10	16	25	35	(20°C, 120Hz)	tanδ	0.26	0.19	0.16	0.14	0.12															
Rated Voltage	6.3	10	16	25	35	(20°C, 120Hz)																							
tanδ	0.26	0.19	0.16	0.14	0.12																								
Endurance	<p>After applying rated voltage with rated ripple current for 2000 hours at 105°C, the capacitors shall meet the following requirements.</p> <table border="1"> <tr> <td>Capacitance Change</td> <td>Within ±30% of the initial value.</td> </tr> <tr> <td>Dissipation Factor</td> <td>Not more than 200% of the specified value.</td> </tr> <tr> <td>Leakage Current</td> <td>Not more than the specified value.</td> </tr> </table>	Capacitance Change	Within ±30% of the initial value.	Dissipation Factor	Not more than 200% of the specified value.	Leakage Current	Not more than the specified value.																						
Capacitance Change	Within ±30% of the initial value.																												
Dissipation Factor	Not more than 200% of the specified value.																												
Leakage Current	Not more than the specified value.																												
Low Temperature Stability Impedance Ratio(MAX)	<table border="1"> <tr> <td>Rated Voltage</td> <td>6.3</td> <td>10</td> <td>16</td> <td>25</td> <td>35</td> <td>(120Hz)</td> </tr> <tr> <td>Z(-25°C)/Z(20°C)</td> <td>2</td> <td>2</td> <td>2</td> <td>2</td> <td>2</td> <td></td> </tr> <tr> <td>Z(-40°C)/Z(20°C)</td> <td>3</td> <td>3</td> <td>3</td> <td>3</td> <td>3</td> <td></td> </tr> <tr> <td>Z(-55°C)/Z(20°C)</td> <td>4</td> <td>4</td> <td>4</td> <td>3</td> <td>3</td> <td></td> </tr> </table>	Rated Voltage	6.3	10	16	25	35	(120Hz)	Z(-25°C)/Z(20°C)	2	2	2	2	2		Z(-40°C)/Z(20°C)	3	3	3	3	3		Z(-55°C)/Z(20°C)	4	4	4	3	3	
Rated Voltage	6.3	10	16	25	35	(120Hz)																							
Z(-25°C)/Z(20°C)	2	2	2	2	2																								
Z(-40°C)/Z(20°C)	3	3	3	3	3																								
Z(-55°C)/Z(20°C)	4	4	4	3	3																								

◆MULTIPLIER FOR RIPPLE CURRENT

Frequency Coefficient

(Hz) Frequency		120	1k	10k	100k≤
Coefficient	4.7μF	0.42	0.60	0.80	1.00
	10~33μF	0.45	0.75	0.90	1.00
	47~100μF	0.50	0.80	0.95	1.00
	220~1000μF	0.60	0.85	0.95	1.00

◆MARKING

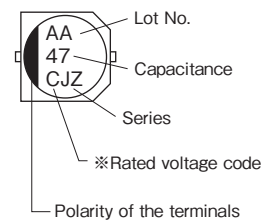

※ Voltage Code

Rated Voltage	6.3	10	16	25	35
Rated Voltage code	j	A	C	E	V

◆PART NUMBER

□□□    JZV    □□□□□    M    □□□    D×L  
 Rated Voltage    Series    Rated Capacitance    Capacitance Tolerance    Option    Case Size

◆ **DIMENSIONS**

(mm)

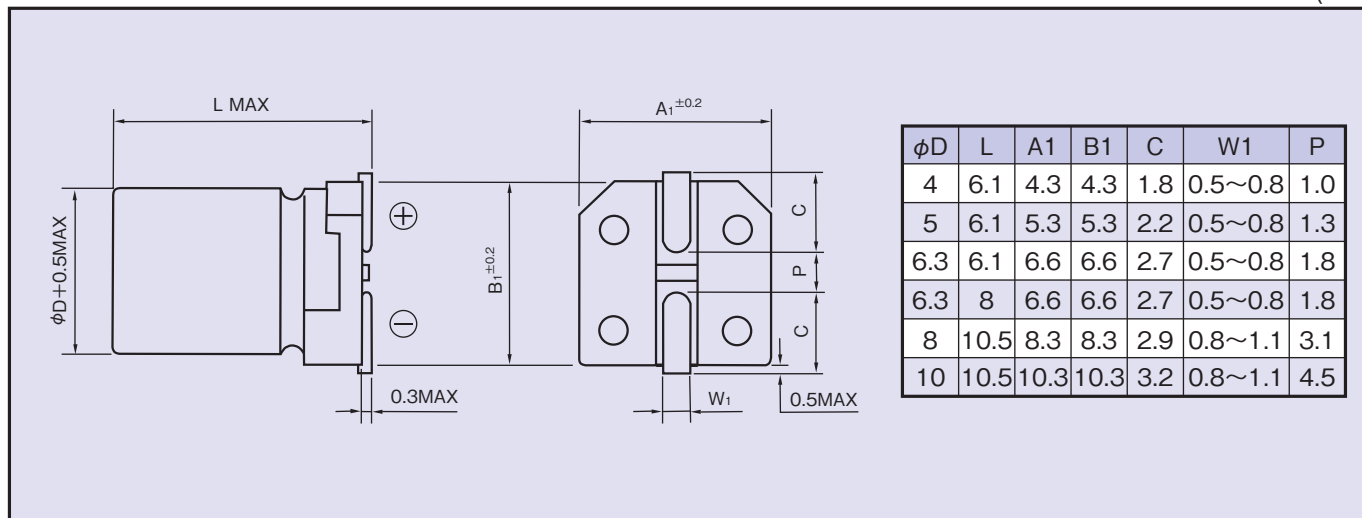

◆ **STANDARD SIZE**

Size φD×L(mm), Ripple Current (mA r.m.s./105°C, 100kHz), Impedance(Ω MAX/20°C, 100kHz)

Cap(μF) \ WV (V.DC)	6.3 (0J)			10 (1A)			16 (1C)		
	Size	Ripple	Impedance	Size	Ripple	Impedance	Size	Ripple	Impedance
10							4×6.1	90	1.35
22	4×6.1	90	1.35				4×6.1	90	1.35
33				4×6.1	90	1.35	5×6.1	170	0.70
47	4×6.1	90	1.35				5×6.1	170	0.70
	5×6.1	170	0.70				6.3×6.1	250	0.36
100	5×6.1	170	0.70				6.3×6.1	250	0.36
	6.3×6.1	250	0.36				6.3×8	300	0.34
220	6.3×6.1	250	0.36	6.3×8	300	0.34	6.3×8	300	0.34
	6.3×8	300	0.34						
330	6.3×8	300	0.34				8×10.5	600	0.16
470				8×10.5	600	0.16	8×10.5	600	0.16
680				8×10.5	600	0.16	10×10.5	850	0.08
1000	8×10.5	600	0.16	10×10.5	850	0.08			

Cap(μF) \ WV (V.DC)	25 (1E)			35 (1V)		
	Size	Ripple	Impedance	Size	Ripple	Impedance
4.7				4×6.1	90	1.45
10				4×6.1	90	1.45
				5×6.1	170	0.70
22				5×6.1	170	0.70
				6.3×6.1	250	0.36
33	5×6.1	170	0.70	6.3×6.1	250	0.36
	6.3×6.1	250	0.36			
47	6.3×6.1	250	0.36	6.3×6.1	250	0.36
				6.3×8	300	0.34
100	6.3×8	300	0.34	6.3×8	300	0.34
				8×10.5	600	0.16
220	8×10.5	600	0.16	8×10.5	600	0.16
330	8×10.5	600	0.16	10×10.5	850	0.09
470	10×10.5	850	0.09			