

Features

- Serial Peripheral Interface (SPI) Compatible
- Supports SPI Modes 0 (0,0) and 3 (1,1)
 - Data Sheet Describes Mode 0 Operation
- Medium-voltage and Standard-voltage Operation
 - 2.7 ($V_{CC} = 2.7V$ to 5.5V)
- Extended Temperature Range $-40^{\circ}C$ to $125^{\circ}C$
- 5.0 MHz Clock Rate
- 32-byte Page Mode
- Block Write Protection
 - Protect 1/4, 1/2, or Entire Array
- Write Protect (\overline{WP}) Pin and Write Disable Instructions for Both Hardware and Software Data Protection
- Self-timed Write Cycle (2 ms [5V] typical)
- High Reliability
 - Endurance: One Million Write Cycles
 - Data Retention: 100 Years
- 8-lead JEDEC SOIC Packages and 8-lead TSSOP Packages

1. Description

The AT25080A/160A/320A/640A provides 8192/16384/32768/65536 bits of serial electrically-erasable programmable read-only memory (EEPROM) organized as 1024/2048/4096/8192 words of 8 bits each. The device is optimized for use in many automotive applications where low-power and low-voltage operation are essential. The AT25080A/160A/320A/640A is available in space-saving 8-lead JEDEC SOIC and 8-lead TSSOP packages.

The AT25080A/160A/320A/640A is enabled through the Chip Select pin (\overline{CS}) and accessed via a three-wire interface consisting of Serial Data Input (SI), Serial Data Output (SO), and Serial Clock (SCK). All programming cycles are completely self-timed, and no separate erase cycle is required before write.

Block write protection is enabled by programming the status register with one of four blocks of write protection. Separate program enable and program disable instructions are provided for additional data protection. Hardware data protection is provided via the \overline{WP} pin to protect against inadvertent write attempts to the status register. The \overline{HOLD} pin may be used to suspend any serial communication without resetting the serial sequence.



**SPI
Automotive
Temperature
Serial
EEPROMs
8K (1024 x 8)
16K (2048 x 8)
32K (4096 x 8)
64K (8192 x 8)**

**AT25080A
AT25160A
AT25320A⁽¹⁾
AT25640A⁽²⁾**

1. AT25320A not recommended for new design; replaced by AT25320B Automotive.
2. AT25640A not recommended for new design; replaced by AT25640B Automotive.



Table 1-1. Pin Configurations

Pin Name	Function
\overline{CS}	Chip Select
SCK	Serial Data Clock
SI	Serial Data Input
SO	Serial Data Output
GND	Ground
VCC	Power Supply
\overline{WP}	Write Protect
\overline{HOLD}	Suspends Serial Input
NC	No Connect
DC	Don't Connect

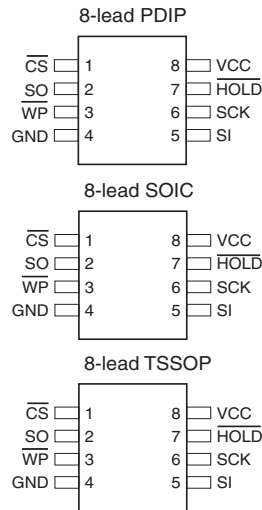

Absolute Maximum Ratings*

Operating Temperature	-40°C to +125°C
Storage Temperature	-65°C to +150°C
Voltage on Any Pin with Respect to Ground	-1.0V to +7.0V
Maximum Operating Voltage	6.25V
DC Output Current	5.0 mA

***NOTICE:** Stresses beyond those listed under “Absolute Maximum Ratings” may cause permanent damage to the device. This is a stress rating only and functional operation of the device at these or any other conditions beyond those indicated in the operational sections of this specification is not implied. Exposure to absolute maximum rating conditions for extended periods may affect device reliability.

Figure 1-1. Block Diagram

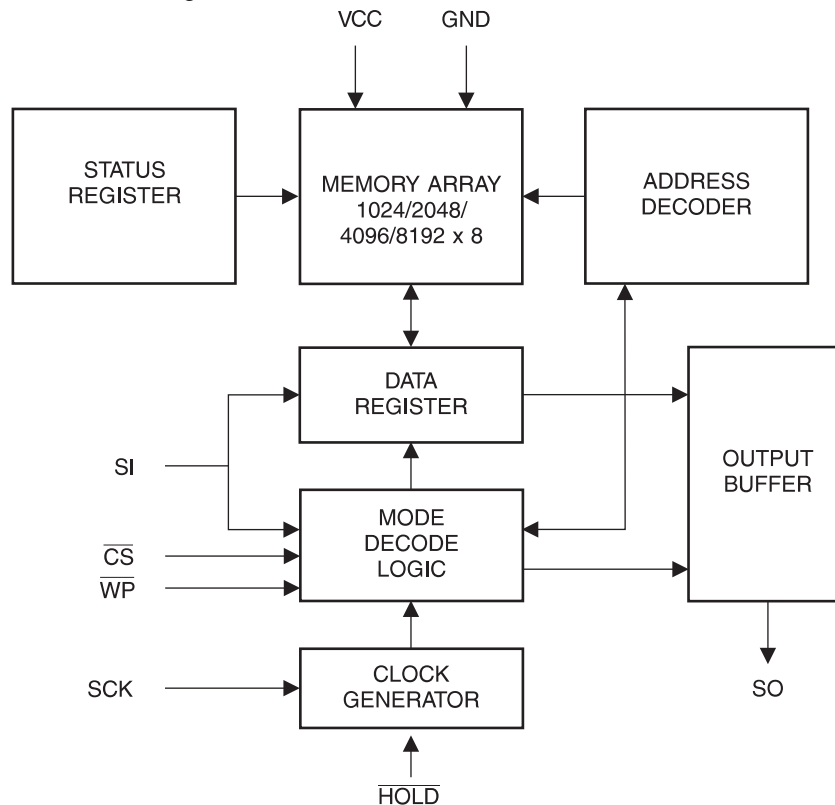

Table 1-2. Pin Capacitance⁽¹⁾

Applicable over recommended operating range from $T_A = 25^\circ\text{C}$, $f = 1.0\text{ MHz}$, $V_{CC} = +5.0\text{V}$ (unless otherwise noted)

Symbol	Test Conditions	Max	Units	Conditions
C_{OUT}	Output Capacitance (SO)	8	pF	$V_{OUT} = 0\text{V}$
C_{IN}	Input Capacitance (\overline{CS} , SCK, SI, WP, \overline{HOLD})	6	pF	$V_{IN} = 0\text{V}$

Note: 1. This parameter is characterized and is not 100% tested.

Table 1-3. DC Characteristics

 Applicable over recommended operating range from: $T_A = -40^{\circ}\text{C}$ to $+125^{\circ}\text{C}$, $V_{CC} = +2.7\text{V}$ to $+5.5\text{V}$

Symbol	Parameter	Test Condition	Min	Typ	Max	Units
V_{CC1}	Supply Voltage		2.7		5.5	V
I_{CC1}	Supply Current	$V_{CC} = 5.0\text{V}$ at 5 MHz, SO = Open, Read			6.0	mA
I_{CC2}	Supply Current	$V_{CC} = 5.0\text{V}$ at 1 MHz			3.0	mA
I_{CC3}	Supply Current	$V_{CC} = 5.0\text{V}$ at 5 MHz, SO = Open, Read, Write			7.0	mA
I_{SB1}	Standby Current	$V_{CC} = 2.7\text{V}$, $\overline{CS} = V_{CC}$		0.2	10.0 ⁽¹⁾	μA
I_{SB2}	Standby Current	$V_{CC} = 5.0\text{V}$, $\overline{CS} = V_{CC}$		2.0	13.0 ⁽¹⁾	μA
I_{IL}	Input Leakage	$V_{IN} = 0\text{V}$ to V_{CC}	-3.0			μA
I_{OL}	Output Leakage	$V_{IN} = 0\text{V}$ to V_{CC}	-3.0		3.0	μA
$V_{IL}^{(2)}$	Input Low-voltage		-0.6		$V_{CC} \times 0.3$	V
$V_{IH}^{(2)}$	Input High-voltage		$V_{CC} \times 0.7$		$V_{CC} + 0.5$	V
V_{OL1}	Output Low-voltage	$2.7\text{V} \leq V_{CC} \leq 5.5\text{V}$			0.4	V
V_{OH1}	Output High-voltage		$I_{OL} = 3.0\text{ mA}$			
			$I_{OH} = -1.6\text{ mA}$	$V_{CC} - 0.8$		V

- Note: 1. Worst case measured at 125°C
 2. V_{IL} min and V_{IH} max are reference only and are not tested.

Table 1-4. AC Characteristics

Applicable over recommended operating range from $T_A = -40^{\circ}\text{C}$ to $+125^{\circ}\text{C}$, $V_{CC} = \text{As Specified}$, $CL = 1$ TTL Gate and 100 pF (unless otherwise noted).

Symbol	Parameter	Voltage	Min	Max	Units
f_{SCK}	SCK Clock Frequency	2.7–5.5	0	5.0	MHz
t_{RI}	Input Rise Time	2.7–5.5		2	μs
t_{FI}	Input Fall Time	2.7–5.5		2	μs
t_{WH}	SCK High Time	2.7–5.5	40		ns
t_{WL}	SCK Low Time	2.7–5.5	40		ns
t_{CS}	$\overline{\text{CS}}$ High Time	2.7–5.5	80		ns
t_{CSS}	$\overline{\text{CS}}$ Setup Time	2.7–5.5	80		ns
t_{CSH}	$\overline{\text{CS}}$ Hold Time	2.7–5.5	80		ns
t_{SU}	Data In Setup Time	2.7–5.5	5		ns
t_{H}	Data In Hold Time	2.7–5.5	20		ns
t_{HD}	$\overline{\text{Hold}}$ Setup Time	2.7–5.5	40		ns
t_{CD}	$\overline{\text{Hold}}$ Hold Time	2.7–5.5	40		ns
t_{V}	Output Valid	2.7–5.5	0	40	ns
t_{HO}	Output Hold Time	2.7–5.5	0		ns
t_{LZ}	$\overline{\text{Hold}}$ to Output Low Z	2.7–5.5	0	40	ns
t_{HZ}	$\overline{\text{Hold}}$ to Output High Z	2.7–5.5		80	ns
t_{DIS}	Output Disable Time	2.7–5.5		80	ns
t_{WC}	Write Cycle Time	2.7–5.5		5	ms
Endurance ⁽¹⁾	5.0V, 25°C, Page Mode		1M		Write Cycles

Note: 1. This parameter is characterized and is not 100% tested.

2. Serial Interface Description

MASTER: The device that generates the serial clock.

SLAVE: Because the serial clock pin (SCK) is always an input, the AT25080A/160A/320A/640A always operates as a slave.

TRANSMITTER/RECEIVER: The AT25080A/160A/320A/640A has separate pins designated for data transmission (SO) and reception (SI).

MSB: The Most Significant Bit (MSB) is the first bit transmitted and received.

SERIAL OP-CODE: After the device is selected with $\overline{\text{CS}}$ going low, the first byte will be received. This byte contains the op-code that defines the operations to be performed.

INVALID OP-CODE: If an invalid op-code is received, no data will be shifted into the AT25080A/160A/320A/640A, and the serial output pin (SO) will remain in a high impedance state until the falling edge of $\overline{\text{CS}}$ is detected again. This will reinitialize the serial communication.

CHIP SELECT: The AT25080A/160A/320A/640A is selected when the \overline{CS} pin is low. When the device is not selected, data will not be accepted via the SI pin, and the serial output pin (SO) will remain in a high impedance state.

HOLD: The \overline{HOLD} pin is used in conjunction with the \overline{CS} pin to select the AT25080A/160A/320A/640A. When the device is selected and a serial sequence is underway, \overline{HOLD} can be used to pause the serial communication with the master device without resetting the serial sequence. To pause, the \overline{HOLD} pin must be brought low while the SCK pin is low. To resume serial communication, the \overline{HOLD} pin is brought high while the SCK pin is low (SCK may still toggle during \overline{HOLD}). Inputs to the SI pin will be ignored while the SO pin is in the high impedance state.

WRITE PROTECT: The write protect pin (\overline{WP}) will allow normal read/write operations when held high. When the \overline{WP} pin is brought low and WPEN bit is "1", all write operations to the status register are inhibited. \overline{WP} going low while \overline{CS} is still low will interrupt a write to the status register. If the internal write cycle has already been initiated, \overline{WP} going low will have no effect on any write operation to the status register. The \overline{WP} pin function is blocked when the WPEN bit in the status register is "0". This will allow the user to install the AT25080A/160A/320A/640A in a system with the \overline{WP} pin tied to ground and still be able to write to the status register. All \overline{WP} pin functions are enabled when the WPEN bit is set to "1".

Figure 2-1. SPI Serial Interface

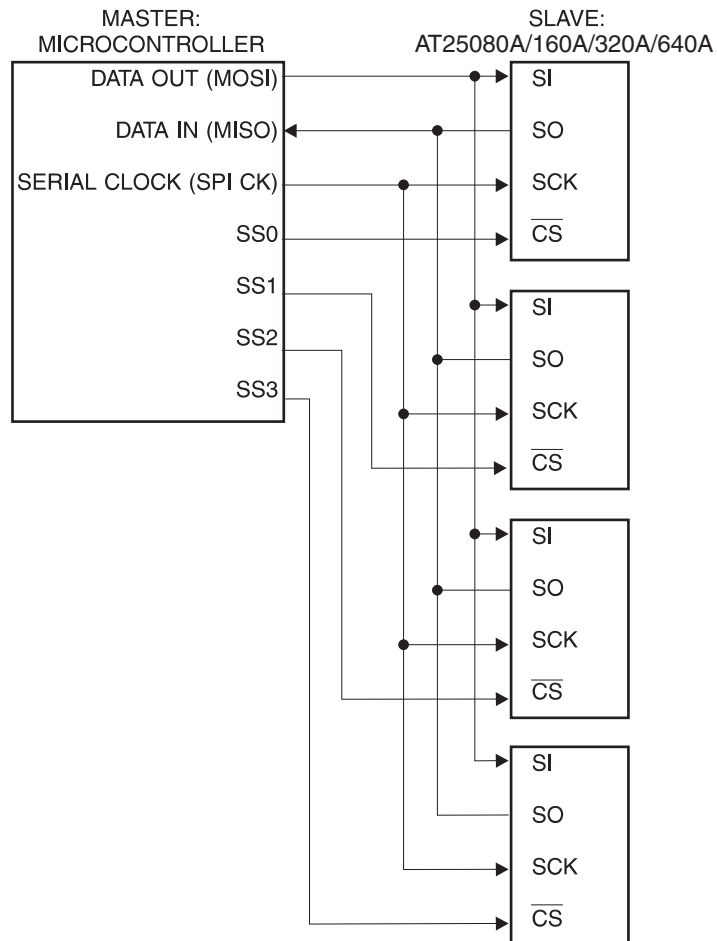

3. Functional Description

The AT25080A/160A/320A/640A is designed to interface directly with the synchronous serial peripheral interface (SPI) of the 6805 and 68HC11 series of microcontrollers.

The AT25080A/160A/320A/640A utilizes an 8-bit instruction register. The list of instructions and their operation codes are contained in [Table 3-1](#). All instructions, addresses, and data are transferred with the MSB first and start with a high-to-low CS transition.

Table 3-1. Instruction Set for the AT25080A/160A/320A/640A

Instruction Name	Instruction Format	Operation
WREN	0000 X110	Set Write Enable Latch
WRDI	0000 X100	Reset Write Enable Latch
RDSR	0000 X101	Read Status Register
WRSR	0000 X001	Write Status Register
READ	0000 X011	Read Data from Memory Array
WRITE	0000 X010	Write Data to Memory Array

WRITE ENABLE (WREN): The device will power up in the write disable state when V_{CC} is applied. All programming instructions must therefore be preceded by a Write Enable instruction.

WRITE DISABLE (WRDI): To protect the device against inadvertent writes, the Write Disable instruction disables all programming modes. The WRDI instruction is independent of the status of the \overline{WP} pin.

READ STATUS REGISTER (RDSR): The Read Status Register instruction provides access to the status register. The READY/BUSY and Write Enable status of the device can be determined by the RDSR instruction. Similarly, the block write protection bits indicate the extent of protection employed. These bits are set by using the WRSR instruction.

Table 3-2. Status Register Format

Bit 7	Bit 6	Bit 5	Bit 4	Bit 3	Bit 2	Bit 1	Bit 0
WPEN	X	X	X	BP1	BP0	WEN	\overline{RDY}

Table 3-3. Read Status Register Bit Definition

Bit	Definition
Bit 0 (\overline{RDY})	Bit 0 = "0" (\overline{RDY}) indicates the device is ready. Bit 0 = "1" indicates the write cycle is in progress.
Bit 1 (WEN)	Bit 1 = "0" indicates the device is not write-enabled. Bit 1 = "1" indicates the device is write-enabled.
Bit 2 (BP0)	See Table 3-4 on page 8 .
Bit 3 (BP1)	See Table 3-4 on page 8 .

Table 3-3. Read Status Register Bit Definition

Bit	Definition
Bits 4 – 6	are “0”s when device is not in an internal write cycle.
Bit 7 (WPEN)	See Table 3-5 on page 9 .
Bits 0 – 7	are “1”s during an internal write cycle.

WRITE STATUS REGISTER (WRSR): The WRSR instruction allows the user to select one of four levels of protection. The AT25080A/160A/320A/640A is divided into four array segments. One-quarter, one-half, or all of the memory segments can be protected. Any of the data within any selected segment will therefore be read only. The block write protection levels and corresponding status register control bits are shown in [Table 3-4](#).

Bits BP0, BP1, and WPEN are nonvolatile cells that have the same properties and functions as the regular memory cells (e.g., WREN, t_{WC} , RDSR).

Table 3-4. Block Write Protect Bits

Level	Status Register Bits		Array Addresses Protected			
	BP1	BP0	AT25080A	AT25160A	AT25320A	AT25640A
0	0	0	None	None	None	None
1 (1/4)	0	1	0300 – 03FF	0600 – 07FF	0C00 – 0FFF	1800 – 1FFF
2 (1/2)	1	0	0200 – 03FF	0400 – 07FF	0800 – 0FFF	1000 – 1FFF
3 (All)	1	1	0000 – 03FF	0000 – 07FF	0000 – 0FFF	0000 – 1FFF

The WRSR instruction also allows the user to enable or disable the write protect (\overline{WP}) pin through the use of the write protect enable (WPEN) bit. Hardware write protection is enabled when the \overline{WP} pin is low and the WPEN bit is “1”. Hardware write protection is disabled when either the \overline{WP} pin is high or the WPEN bit is “0”. When the device is hardware write protected, writes to the status register, including the block protect bits and the WPEN bit, and the block-protected sections in the memory array are disabled. Writes are only allowed to sections of the memory that are not block-protected.

NOTE: When the WPEN bit is hardware write protected, it cannot be changed back to “0” as long as the \overline{WP} pin is held low.

Table 3-5. WPEN Operation

WPEN	\overline{WP}	WEN	Protected Blocks	Unprotected Blocks	Status Register
0	X	0	Protected	Protected	Protected
0	X	1	Protected	Writeable	Writeable
1	Low	0	Protected	Protected	Protected
1	Low	1	Protected	Writeable	Protected
X	High	0	Protected	Protected	Protected
X	High	1	Protected	Writeable	Writeable

READ SEQUENCE (READ): Reading the AT25080A/160A/320A/640A via the serial output (SO) pin requires the following sequence. After the \overline{CS} line is pulled low to select a device, the read op-code is transmitted via the SI line followed by the byte address to be read (A15–A0, see Table 3-6). Upon completion, any data on the SI line will be ignored. The data (D7–D0) at the specified address is then shifted out onto the SO line. If only one byte is to be read, the \overline{CS} line should be driven high after the data comes out. The read sequence can be continued since the byte address is automatically incremented and data will continue to be shifted out. When the highest address is reached, the address counter will roll over to the lowest address, allowing the entire memory to be read in one continuous read cycle.

WRITE SEQUENCE (WRITE): In order to program the AT25080A/160A/320A/640A, two separate instructions must be executed. First, the device **must be write enabled** via the WREN instruction. Then a Write (WRITE) instruction may be executed. Also, the address of the memory location(s) to be programmed must be outside the protected address field location selected by the block write protection level. During an internal write cycle, all commands will be ignored except the RDSR instruction.

A Write instruction requires the following sequence. After the \overline{CS} line is pulled low to select the device, the WRITE op-code is transmitted via the SI line followed by the byte address (A15–A0) and the data (D7–D0) to be programmed (See Table 3-6). Programming will start after the \overline{CS} pin is brought high. The low-to-high transition of the \overline{CS} pin must occur during the SCK low-time immediately after clocking in the D0 (LSB) data bit.

The READY/BUSY status of the device can be determined by initiating a read status register (RDSR) instruction. If Bit 0 = “1”, the write cycle is still in progress. If Bit 0 = “0”, the write cycle has ended. Only the RDSR instruction is enabled during the write programming cycle.

The AT25080A/160A/320A/640A is capable of a 32-byte page write operation. After each byte of data is received, the five low-order address bits are internally incremented by one; the high-order bits of the address will remain constant. If more than 32 bytes of data are transmitted, the address counter will roll over and the previously written data will be overwritten. The AT25080A/160A/320A/640A is automatically returned to the write disable state at the completion of a write cycle.

NOTE: If the device is not write enabled (WREN), the device will ignore the write instruction and will return to the standby state, when \overline{CS} is brought high. A new \overline{CS} falling edge is required to reinitiate the serial communication.

Table 3-6. Address Key

Address	AT25080A	AT25160A	AT25320A	AT25640A
A_N	A_9-A_0	$A_{10}-A_0$	$A_{11}-A_0$	$A_{12}-A_0$
Don't Care Bits	$A_{15}-A_{10}$	$A_{15}-A_{11}$	$A_{15}-A_{12}$	$A_{15}-A_{13}$

4. Timing Diagrams

Figure 4-1. Synchronous Data Timing (for Mode 0)

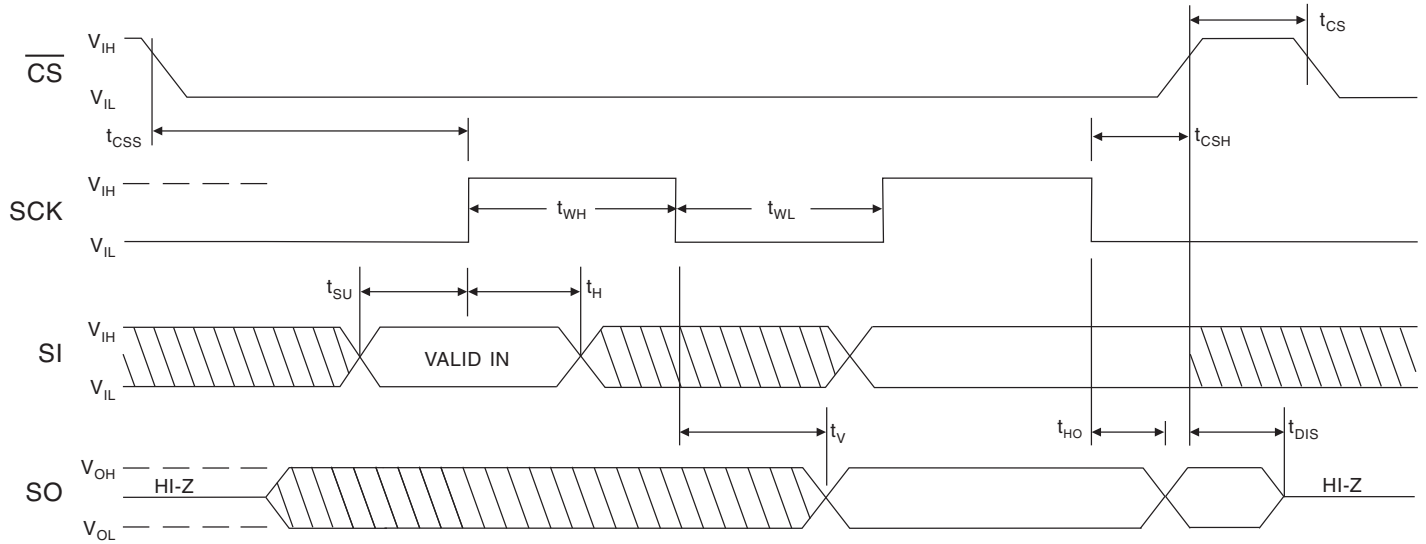

Figure 4-2. WREN Timing

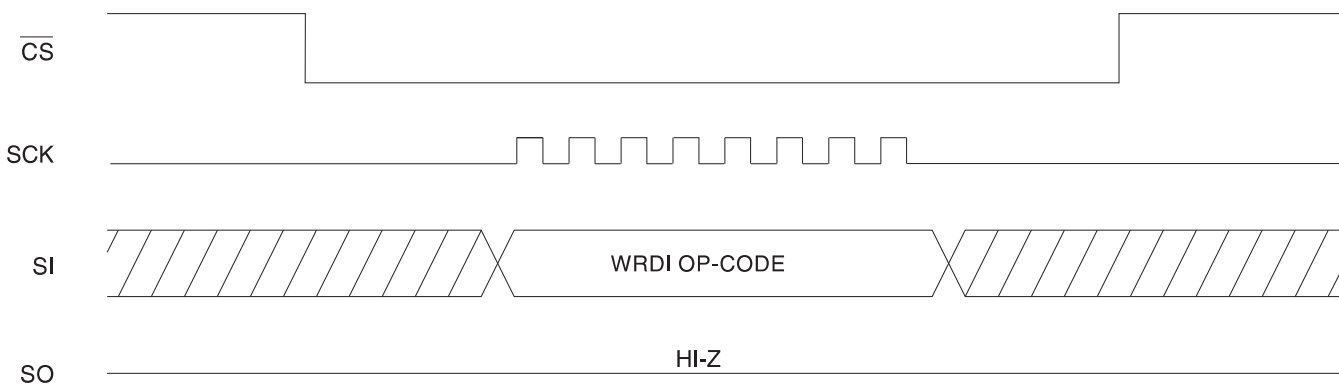

Figure 4-3. WRDI Timing

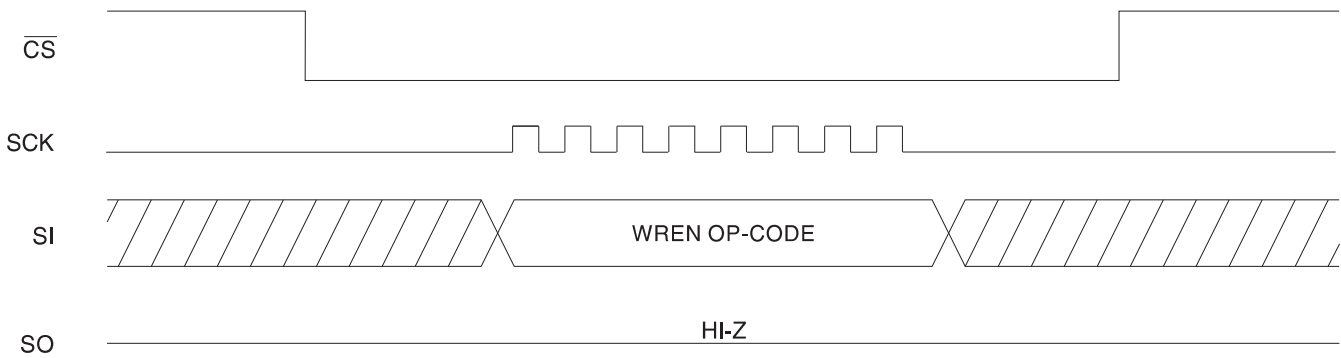

Figure 4-4. RDSR Timing

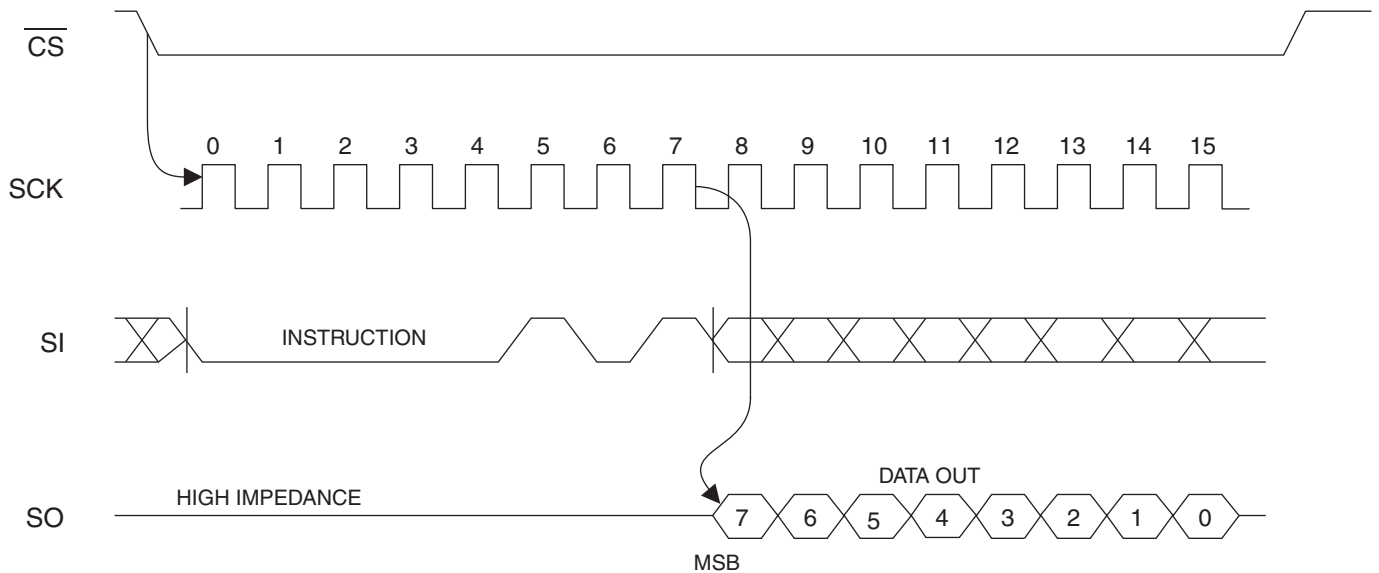

Figure 4-5. WRSR Timing

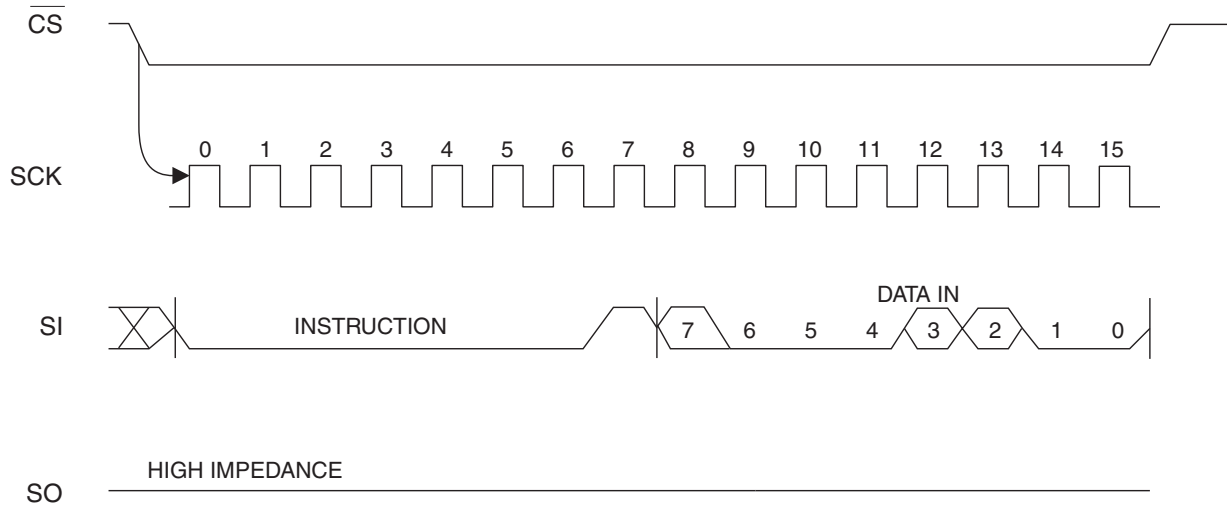

Figure 4-6. READ Timing

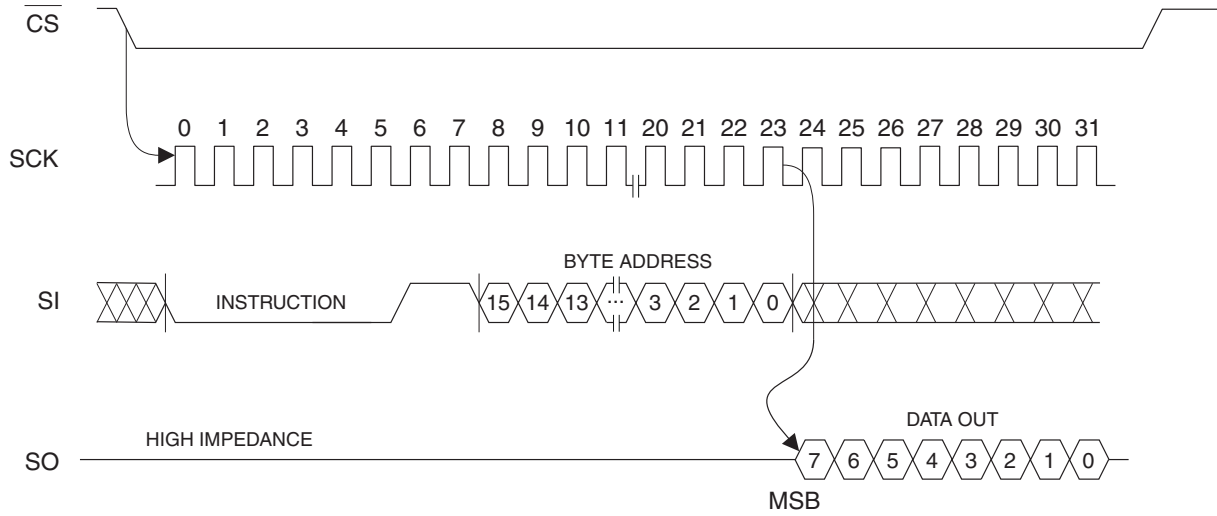
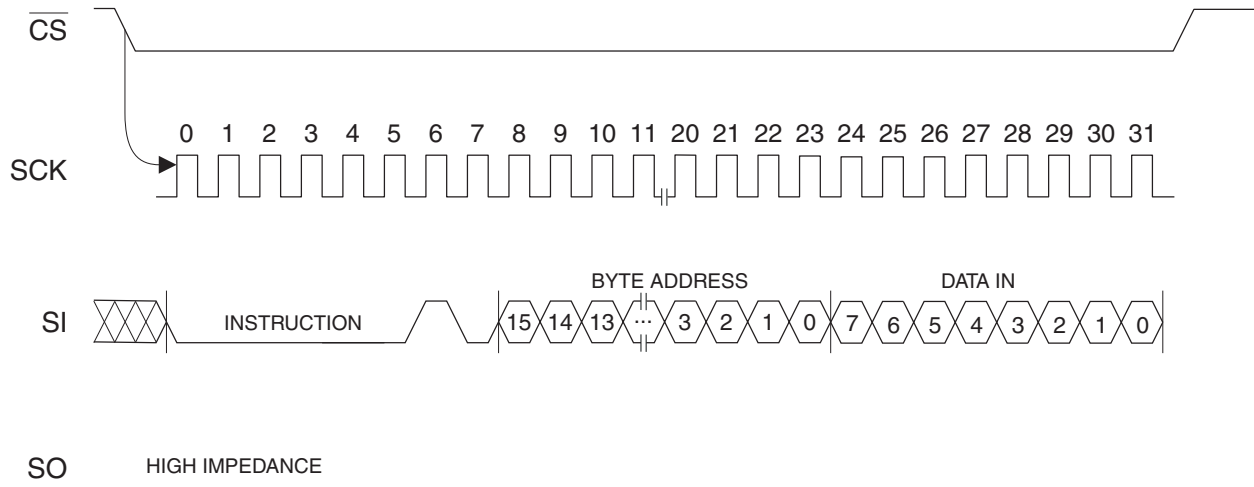
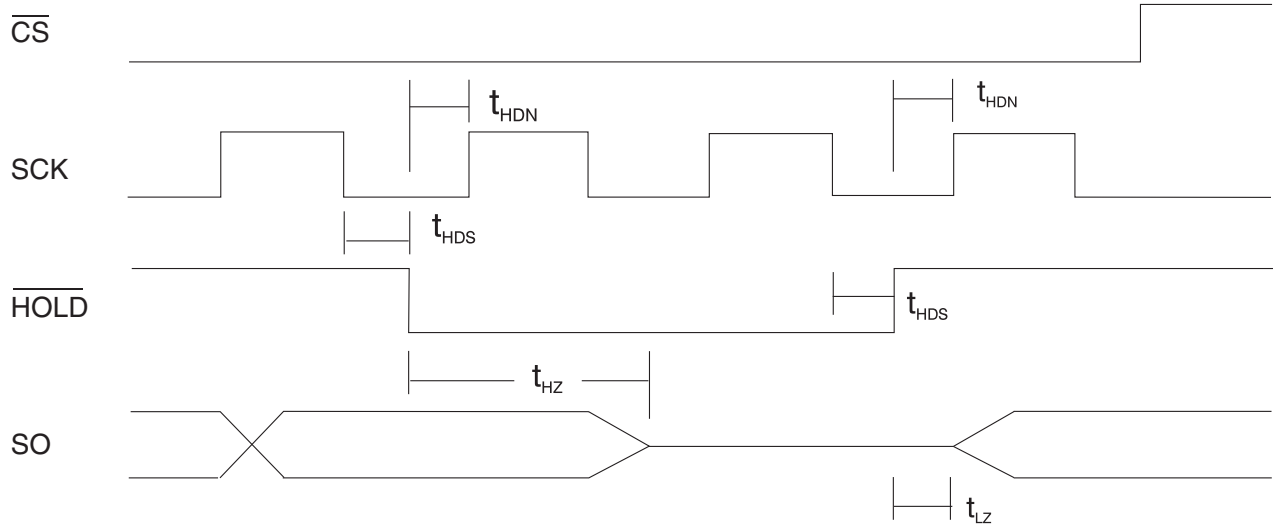

Figure 4-7. WRITE Timing



4.0.1 $\overline{\text{HOLD}}$ Timing





5. AT25080A Ordering Information

Ordering Code	Package	Operation Range
AT25080AN-10SQ-2.7 AT25080A-10TQ-2.7	8S1 8A2	Lead-free/Halogen-free Automotive Temperature (-40°C to 125°C)

Package Type	
8S1	8-lead, 0.150" Wide, Plastic Gull Wing Small Outline (JEDEC SOIC)
8A2	8-lead, 4.4 mm Body, Plastic Thin Shrink Small Outline Package (TSSOP)
Options	
-2.7	Low Voltage (2.7V to 5.5V)

6. AT25160A Ordering Information

Ordering Code	Package	Operation Range
AT25160AN-10SQ-2.7 AT25160A-10TQ-2.7	8S1 8A2	Lead-free/Halogen-free Automotive Temperature (-40°C to 125°C)

Package Type	
8S1	8-lead, 0.150" Wide, Plastic Gull Wing Small Outline (JEDEC SOIC)
8A2	8-lead, 4.4 mm Body, Plastic Thin Shrink Small Outline Package (TSSOP)
Options	
-2.7	Low Voltage (2.7V to 5.5V)



7. AT25320A Ordering Information

Ordering Code	Package	Operation Range
AT25320AN-10SQ-2.7 ⁽¹⁾ AT25320A-10TQ-2.7 ⁽¹⁾	8S1 8A2	Lead-free/Halogen-free Automotive Temperature (-40°C to 125°C)

Note: 1. AT25320A not recommended for new design; replaced by AT25320B Automotive.

Package Type	
8S1	8-lead, 0.150" Wide, Plastic Gull Wing Small Outline (JEDEC SOIC)
8A2	8-lead, 4.4 mm Body, Plastic Thin Shrink Small Outline Package (TSSOP)
Options	
-2.7	Low Voltage (2.7V to 5.5V)

8. AT25640A Ordering Information

Ordering Code	Package	Operation Range
AT25640AN-10SQ-2.7 ⁽¹⁾ AT25640A-10TQ-2.7 ⁽¹⁾	8S1 8A2	Lead-free/Halogen-free Automotive Temperature (-40°C to 125°C)

Note: 1. AT25640A not recommended for new design; replaced by AT25640B Automotive.

Package Type	
8S1	8-lead, 0.150" Wide, Plastic Gull Wing Small Outline (JEDEC SOIC)
8A2	8-lead, 4.4 mm Body, Plastic Thin Shrink Small Outline Package (TSSOP)
Options	
-2.7	Low Voltage (2.7V to 5.5V)

9. Packaging Information

8S1 – JEDEC SOIC

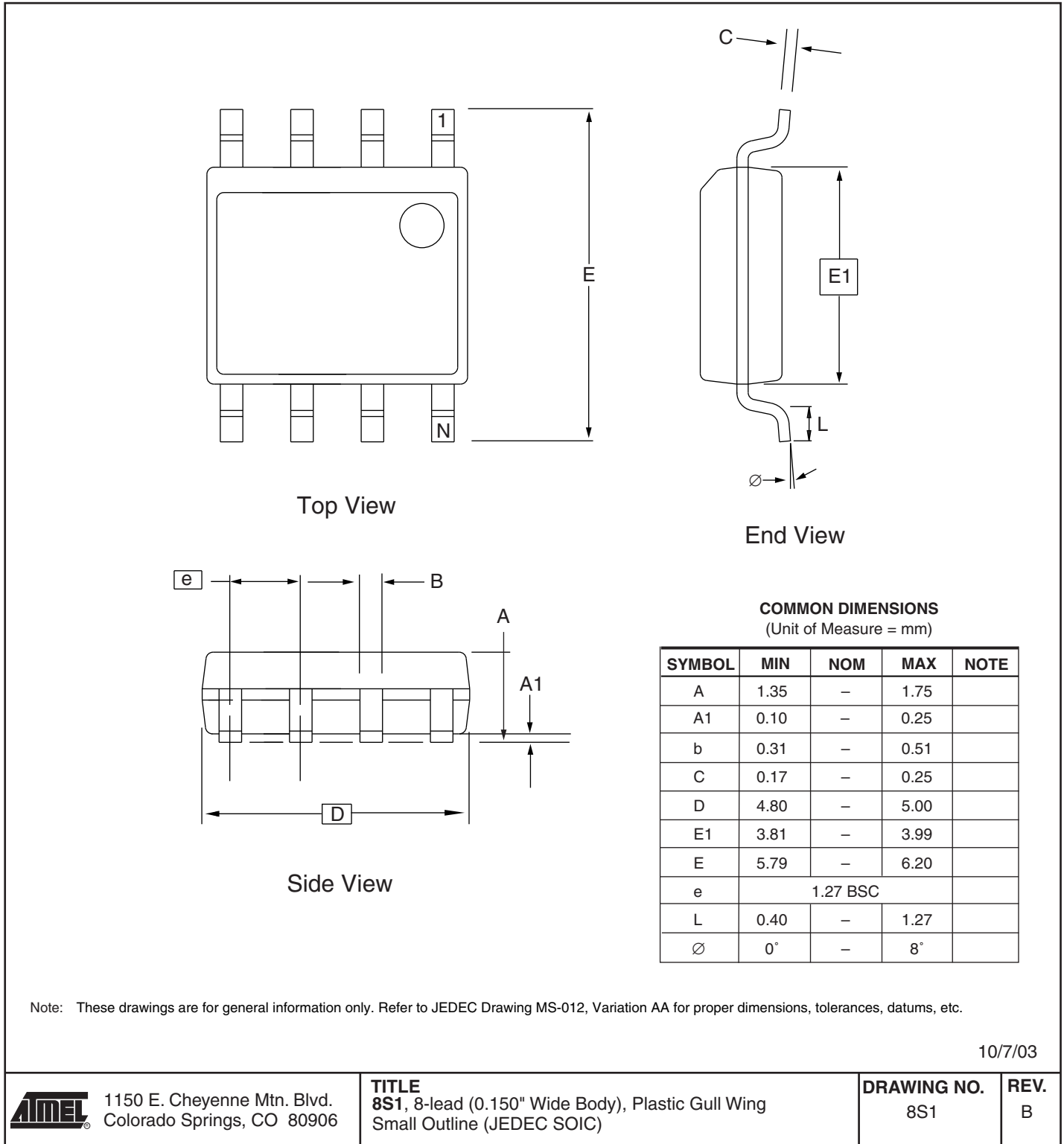

8A2 – TSSOP

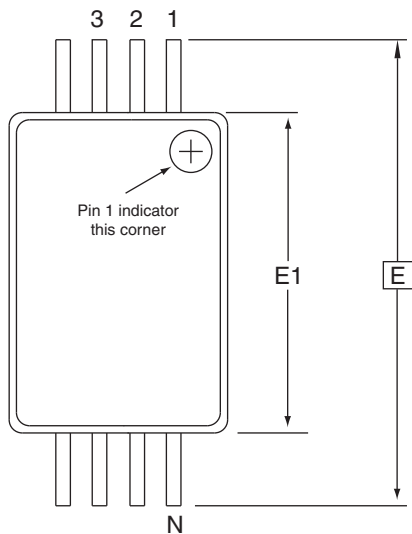

Top View

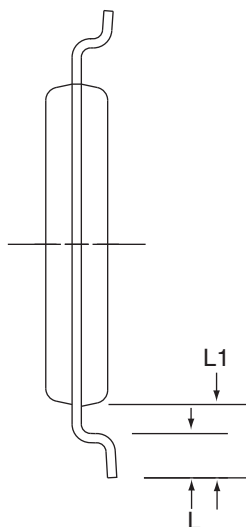

End View

COMMON DIMENSIONS
(Unit of Measure = mm)

SYMBOL	MIN	NOM	MAX	NOTE
D	2.90	3.00	3.10	2, 5
E	6.40 BSC			
E1	4.30	4.40	4.50	3, 5
A	-	-	1.20	
A2	0.80	1.00	1.05	
b	0.19	-	0.30	4
e	0.65 BSC			
L	0.45	0.60	0.75	
L1	1.00 REF			

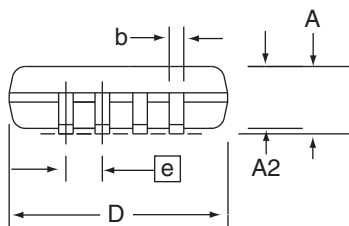

Side View

- Notes:
1. This drawing is for general information only. Refer to JEDEC Drawing MO-153, Variation AA, for proper dimensions, tolerances, datums, etc.
 2. Dimension D does not include mold Flash, protrusions or gate burrs. Mold Flash, protrusions and gate burrs shall not exceed 0.15 mm (0.006 in) per side.
 3. Dimension E1 does not include inter-lead Flash or protrusions. Inter-lead Flash and protrusions shall not exceed 0.25 mm (0.010 in) per side.
 4. Dimension b does not include Dambar protrusion. Allowable Dambar protrusion shall be 0.08 mm total in excess of the b dimension at maximum material condition. Dambar cannot be located on the lower radius of the foot. Minimum space between protrusion and adjacent lead is 0.07 mm.
 5. Dimension D and E1 to be determined at Datum Plane H.

5/30/02



2325 Orchard Parkway
San Jose, CA 95131

TITLE
8A2, 8-lead, 4.4 mm Body, Plastic
Thin Shrink Small Outline Package (TSSOP)

DRAWING NO.
8A2

REV.
B



Revision History

Doc. Rev.	Date	Comments
5028D	8/2012	AT25320A not recommended for new design; replaced by AT25320B Automotive. AT25640A not recommended for new design; replaced by AT25640B Automotive.
5082D	9/2007	Updated to new template Added overline to HOLD in Pin Configuration figure
5082C	2/2007	Implemented revision history Removed PDIP package offering Removed Pb'd parts



Headquarters

Atmel Corporation
2325 Orchard Parkway
San Jose, CA 95131
USA
Tel: 1(408) 441-0311
Fax: 1(408) 487-2600

International

Atmel Asia
Room 1219
Chinachem Golden Plaza
77 Mody Road Tsimshatsui
East Kowloon
Hong Kong
Tel: (852) 2721-9778
Fax: (852) 2722-1369

Atmel Europe
Le Krebs
8, Rue Jean-Pierre Timbaud
BP 309
78054 Saint-Quentin-en-
Yvelines Cedex
France
Tel: (33) 1-30-60-70-00
Fax: (33) 1-30-60-71-11

Atmel Japan
9F, Tonetsu Shinkawa Bldg.
1-24-8 Shinkawa
Chuo-ku, Tokyo 104-0033
Japan
Tel: (81) 3-3523-3551
Fax: (81) 3-3523-7581

Product Contact

Web Site
www.atmel.com

Technical Support
s_eeeprom@atmel.com

Sales Contact
www.atmel.com/contacts

Literature Requests
www.atmel.com/literature

Disclaimer: The information in this document is provided in connection with Atmel products. No license, express or implied, by estoppel or otherwise, to any intellectual property right is granted by this document or in connection with the sale of Atmel products. **EXCEPT AS SET FORTH IN ATMEL'S TERMS AND CONDITIONS OF SALE LOCATED ON ATMEL'S WEB SITE, ATMEL ASSUMES NO LIABILITY WHATSOEVER AND DISCLAIMS ANY EXPRESS, IMPLIED OR STATUTORY WARRANTY RELATING TO ITS PRODUCTS INCLUDING, BUT NOT LIMITED TO, THE IMPLIED WARRANTY OF MERCHANTABILITY, FITNESS FOR A PARTICULAR PURPOSE, OR NON-INFRINGEMENT. IN NO EVENT SHALL ATMEL BE LIABLE FOR ANY DIRECT, INDIRECT, CONSEQUENTIAL, PUNITIVE, SPECIAL OR INCIDENTAL DAMAGES (INCLUDING, WITHOUT LIMITATION, DAMAGES FOR LOSS OF PROFITS, BUSINESS INTERRUPTION, OR LOSS OF INFORMATION) ARISING OUT OF THE USE OR INABILITY TO USE THIS DOCUMENT, EVEN IF ATMEL HAS BEEN ADVISED OF THE POSSIBILITY OF SUCH DAMAGES.** Atmel makes no representations or warranties with respect to the accuracy or completeness of the contents of this document and reserves the right to make changes to specifications and product descriptions at any time without notice. Atmel does not make any commitment to update the information contained herein. Unless specifically provided otherwise, Atmel products are not suitable for, and shall not be used in, automotive applications. Atmel's products are not intended, authorized, or warranted for use as components in applications intended to support or sustain life.

© 2007 Atmel Corporation. All rights reserved. Atmel®, logo and combinations thereof, and others, are registered trademarks or trademarks of Atmel Corporation or its subsidiaries. Other terms and product names may be the trademarks of others.