

## Features

- High Performance, Low Power 32-Bit Atmel® AVR® Microcontroller
  - Compact Single-cycle RISC Instruction Set Including DSP Instruction Set
  - Read-Modify-Write Instructions and Atomic Bit Manipulation
  - Performing 1.49 DMIPS / MHz
    - Up to 91 DMIPS Running at 66 MHz from Flash (1 Wait-State)
    - Up to 49 DMIPS Running at 33MHz from Flash (0 Wait-State)
  - Memory Protection Unit
- Multi-hierarchy Bus System
  - High-Performance Data Transfers on Separate Buses for Increased Performance
  - 15 Peripheral DMA Channels Improves Speed for Peripheral Communication
- Internal High-Speed Flash
  - 512K Bytes, 256K Bytes, 128K Bytes Versions
  - Single Cycle Access up to 33 MHz
  - Prefetch Buffer Optimizing Instruction Execution at Maximum Speed
  - 4ms Page Programming Time and 8ms Full-Chip Erase Time
  - 100,000 Write Cycles, 15-year Data Retention Capability
  - Flash Security Locks and User Defined Configuration Area
- Internal High-Speed SRAM, Single-Cycle Access at Full Speed
  - 64K Bytes (512KB and 256KB Flash), 32K Bytes (128KB Flash)
- External Memory Interface on AT32UC3A0 Derivatives
  - SDRAM / SRAM Compatible Memory Bus (16-bit Data and 24-bit Address Buses)
- Interrupt Controller
  - Autovectorized Low Latency Interrupt Service with Programmable Priority
- System Functions
  - Power and Clock Manager Including Internal RC Clock and One 32KHz Oscillator
  - Two Multipurpose Oscillators and Two Phase-Lock-Loop (PLL) allowing Independent CPU Frequency from USB Frequency
  - Watchdog Timer, Real-Time Clock Timer
- Universal Serial Bus (USB)
  - Device 2.0 Full Speed and On-The-Go (OTG) Low Speed and Full Speed
  - Flexible End-Point Configuration and Management with Dedicated DMA Channels
  - On-chip Transceivers Including Pull-Ups
- Ethernet MAC 10/100 Mbps interface
  - 802.3 Ethernet Media Access Controller
  - Supports Media Independent Interface (MII) and Reduced MII (RMII)
- One Three-Channel 16-bit Timer/Counter (TC)
  - Three External Clock Inputs, PWM, Capture and Various Counting Capabilities
- One 7-Channel 16-bit Pulse Width Modulation Controller (PWM)
- Four Universal Synchronous/Asynchronous Receiver/Transmitters (USART)
  - Independent Baudrate Generator, Support for SPI, IrDA and ISO7816 interfaces
  - Support for Hardware Handshaking, RS485 Interfaces and Modem Line
- Two Master/Slave Serial Peripheral Interfaces (SPI) with Chip Select Signals
- One Synchronous Serial Protocol Controller
  - Supports I2S and Generic Frame-Based Protocols
- One Master/Slave Two-Wire Interface (TWI), 400kbit/s I2C-compatible
- One 8-channel 10-bit Analog-To-Digital Converter
- 16-bit Stereo Audio Bitstream
  - Sample Rate Up to 50 KHz



## 32-Bit Atmel AVR Microcontroller

**AT32UC3A0512**  
**AT32UC3A0256**  
**AT32UC3A0128**  
**AT32UC3A1512**  
**AT32UC3A1256**  
**AT32UC3A1128**

32058K-AVR32-01/12



- **On-Chip Debug System (JTAG interface)**
  - Nexus Class 2+, Runtime Control, Non-Intrusive Data and Program Trace
- **100-pin TQFP (69 GPIO pins), 144-pin LQFP (109 GPIO pins) , 144 BGA (109 GPIO pins)**
- **5V Input Tolerant I/Os**
- **Single 3.3V Power Supply or Dual 1.8V-3.3V Power Supply**

## 1. Description

The AT32UC3A is a complete System-On-Chip microcontroller based on the AVR32 UC RISC processor running at frequencies up to 66 MHz. AVR32 UC is a high-performance 32-bit RISC microprocessor core, designed for cost-sensitive embedded applications, with particular emphasis on low power consumption, high code density and high performance.

The processor implements a Memory Protection Unit (MPU) and a fast and flexible interrupt controller for supporting modern operating systems and real-time operating systems. Higher computation capabilities are achievable using a rich set of DSP instructions.

The AT32UC3A incorporates on-chip Flash and SRAM memories for secure and fast access. For applications requiring additional memory, an external memory interface is provided on AT32UC3A0 derivatives.

The Peripheral Direct Memory Access controller (PDCA) enables data transfers between peripherals and memories without processor involvement. PDCA drastically reduces processing overhead when transferring continuous and large data streams between modules within the MCU.

The PowerManager improves design flexibility and security: the on-chip Brown-Out Detector monitors the power supply, the CPU runs from the on-chip RC oscillator or from one of external oscillator sources, a Real-Time Clock and its associated timer keeps track of the time.

The Timer/Counter includes three identical 16-bit timer/counter channels. Each channel can be independently programmed to perform frequency measurement, event counting, interval measurement, pulse generation, delay timing and pulse width modulation.

The PWM modules provides seven independent channels with many configuration options including polarity, edge alignment and waveform non overlap control. One PWM channel can trigger ADC conversions for more accurate close loop control implementations.

The AT32UC3A also features many communication interfaces for communication intensive applications. In addition to standard serial interfaces like UART, SPI or TWI, other interfaces like flexible Synchronous Serial Controller, USB and Ethernet MAC are available.

The Synchronous Serial Controller provides easy access to serial communication protocols and audio standards like I2S.

The Full-Speed USB 2.0 Device interface supports several USB Classes at the same time thanks to the rich End-Point configuration. The On-The-GO (OTG) Host interface allows device like a USB Flash disk or a USB printer to be directly connected to the processor.

The media-independent interface (MII) and reduced MII (RMII) 10/100 Ethernet MAC module provides on-chip solutions for network-connected devices.

AT32UC3A integrates a class 2+ Nexus 2.0 On-Chip Debug (OCD) System, with non-intrusive real-time trace, full-speed read/write memory access in addition to basic runtime control.

## 2. Configuration Summary

The table below lists all AT32UC3A memory and package configurations:

Device	Flash	SRAM	Ext. Bus Interface	Ethernet MAC	Package
<b>AT32UC3A0512</b>	512 Kbytes	64 Kbytes	yes	yes	144 pin LQFP 144 pin BGA
<b>AT32UC3A0256</b>	256 Kbytes	64 Kbytes	yes	yes	144 pin LQFP 144 pin BGA
<b>AT32UC3A0128</b>	128 Kbytes	32 Kbytes	yes	yes	144 pin LQFP 144 pin BGA
<b>AT32UC3A1512</b>	512 Kbytes	64 Kbytes	no	yes	100 pin TQFP
<b>AT32UC3A1256</b>	256 Kbytes	64 Kbytes	no	yes	100 pin TQFP
<b>AT32UC3A1128</b>	128 Kbytes	32 Kbytes	no	yes	100 pin TQFP

## 3. Abbreviations

- GCLK: Power Manager Generic Clock
- GPIO: General Purpose Input/Output
- HSB: High Speed Bus
- MPU: Memory Protection Unit
- OCD: On Chip Debug
- PB: Peripheral Bus
- PDCA: Peripheral Direct Memory Access Controller (PDC) version A
- USBB: USB On-The-GO Controller version B

### 4. Blockdiagram

Figure 4-1. Blockdiagram

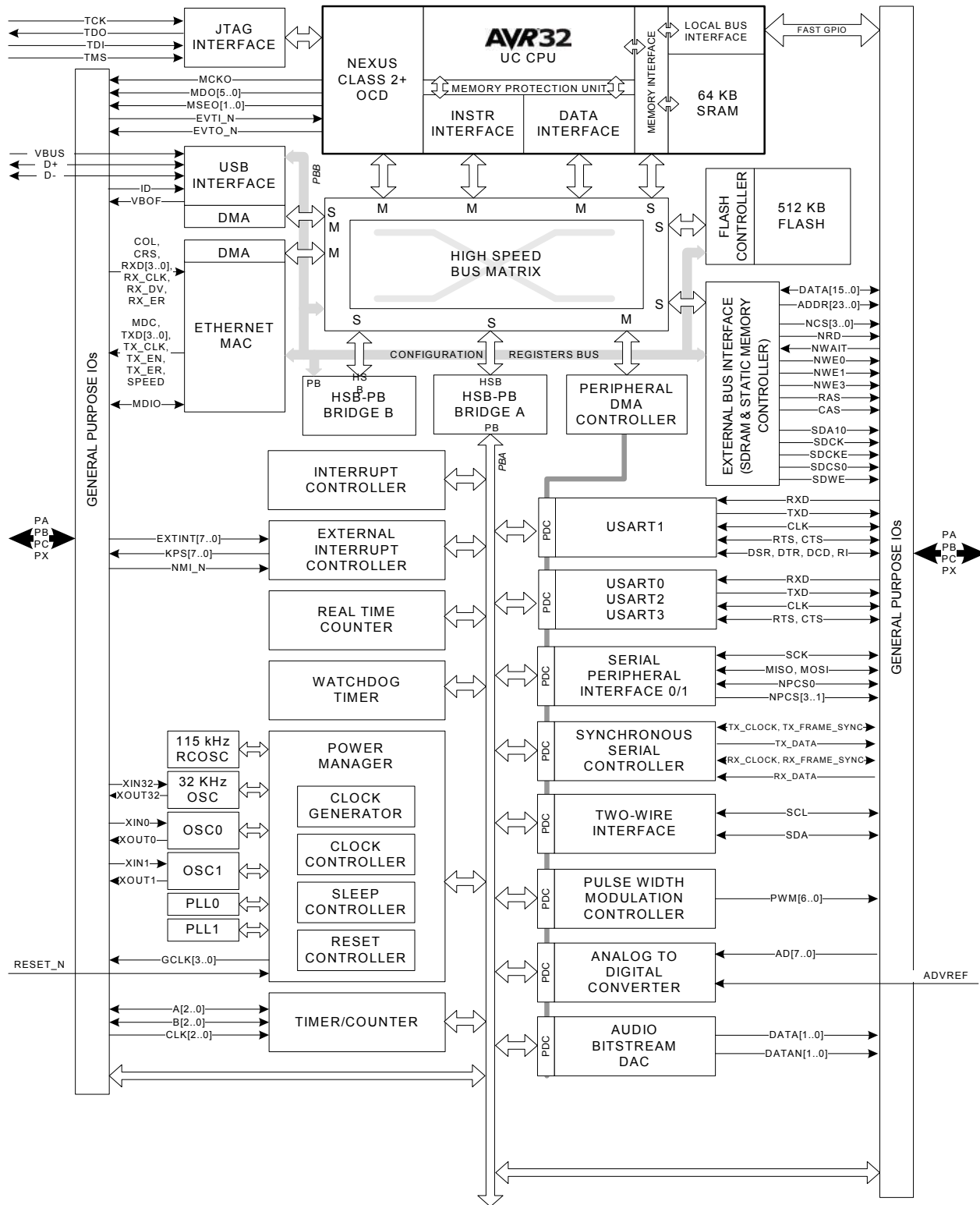

## 4.1 Processor and architecture

### 4.1.1 AVR32 UC CPU

- 32-bit load/store AVR32A RISC architecture.
  - 15 general-purpose 32-bit registers.
  - 32-bit Stack Pointer, Program Counter and Link Register reside in register file.
  - Fully orthogonal instruction set.
  - Privileged and unprivileged modes enabling efficient and secure Operating Systems.
  - Innovative instruction set together with variable instruction length ensuring industry leading code density.
  - DSP extension with saturating arithmetic, and a wide variety of multiply instructions.
- 3 stage pipeline allows one instruction per clock cycle for most instructions.
  - Byte, half-word, word and double word memory access.
  - Multiple interrupt priority levels.
- MPU allows for operating systems with memory protection.

### 4.1.2 Debug and Test system

- IEEE1149.1 compliant JTAG and boundary scan
- Direct memory access and programming capabilities through JTAG interface
- Extensive On-Chip Debug features in compliance with IEEE-ISTO 5001-2003 (Nexus 2.0) Class 2+
  - Low-cost NanoTrace supported.
- Auxiliary port for high-speed trace information
- Hardware support for 6 Program and 2 data breakpoints
- Unlimited number of software breakpoints supported
- Advanced Program, Data, Ownership, and Watchpoint trace supported

### 4.1.3 Peripheral DMA Controller

- Transfers from/to peripheral to/from any memory space without intervention of the processor.
- Next Pointer Support, forbids strong real-time constraints on buffer management.
- Fifteen channels
  - Two for each USART
  - Two for each Serial Synchronous Controller
  - Two for each Serial Peripheral Interface
  - One for each ADC
  - Two for each TWI Interface

### 4.1.4 Bus system

- High Speed Bus (HSB) matrix with 6 Masters and 6 Slaves handled
  - Handles Requests from the CPU Data Fetch, CPU Instruction Fetch, PDCA, USBB, Ethernet Controller, CPU SAB, and to internal Flash, internal SRAM, Peripheral Bus A, Peripheral Bus B, EBI.
  - Round-Robin Arbitration (three modes supported: no default master, last accessed default master, fixed default master)
  - Burst Breaking with Slot Cycle Limit
  - One Address Decoder Provided per Master

- **Peripheral Bus A able to run on at divided bus speeds compared to the High Speed Bus**

[Figure 4-1](#) gives an overview of the bus system. All modules connected to the same bus use the same clock, but the clock to each module can be individually shut off by the Power Manager. The figure identifies the number of master and slave interfaces of each module connected to the High Speed Bus, and which DMA controller is connected to which peripheral.

## 5. Signals Description

The following table gives details on the signal name classified by peripheral

The signals are multiplexed with GPIO pins as described in "[Peripheral Multiplexing on I/O lines](#)" on page 45.

**Table 5-1.** Signal Description List

Signal Name	Function	Type	Active Level	Comments
<b>Power</b>				
VDDPLL	Power supply for PLL	Power Input		1.65V to 1.95 V
VDDCORE	Core Power Supply	Power Input		1.65V to 1.95 V
VDDIO	I/O Power Supply	Power Input		3.0V to 3.6V
VDDANA	Analog Power Supply	Power Input		3.0V to 3.6V
VDDIN	Voltage Regulator Input Supply	Power Input		3.0V to 3.6V
VDDOUT	Voltage Regulator Output	Power Output		1.65V to 1.95 V
GNDANA	Analog Ground	Ground		
GND	Ground	Ground		
<b>Clocks, Oscillators, and PLL's</b>				
XIN0, XIN1, XIN32	Crystal 0, 1, 32 Input	Analog		
XOUT0, XOUT1, XOUT32	Crystal 0, 1, 32 Output	Analog		
<b>JTAG</b>				
TCK	Test Clock	Input		
TDI	Test Data In	Input		
TDO	Test Data Out	Output		
TMS	Test Mode Select	Input		
<b>Auxiliary Port - AUX</b>				
MCKO	Trace Data Output Clock	Output		
MDO0 - MDO5	Trace Data Output	Output		



**Table 5-1.** Signal Description List

Signal Name	Function	Type	Active Level	Comments
MSEO0 - MSEO1	Trace Frame Control	Output		
EVTI_N	Event In	Output	Low	
EVTO_N	Event Out	Output	Low	
<b>Power Manager - PM</b>				
GCLK0 - GCLK3	Generic Clock Pins	Output		
RESET_N	Reset Pin	Input	Low	
<b>Real Time Counter - RTC</b>				
RTC_CLOCK	RTC clock	Output		
<b>Watchdog Timer - WDT</b>				
WDTEXT	External Watchdog Pin	Output		
<b>External Interrupt Controller - EIC</b>				
EXTINT0 - EXTINT7	External Interrupt Pins	Input		
KPS0 - KPS7	Keypad Scan Pins	Output		
NMI_N	Non-Maskable Interrupt Pin	Input	Low	
<b>Ethernet MAC - MACB</b>				
COL	Collision Detect	Input		
CRS	Carrier Sense and Data Valid	Input		
MDC	Management Data Clock	Output		
MDIO	Management Data Input/Output	I/O		
RXD0 - RXD3	Receive Data	Input		
RX_CLK	Receive Clock	Input		
RX_DV	Receive Data Valid	Input		
RX_ER	Receive Coding Error	Input		
SPEED	Speed			
TXD0 - TXD3	Transmit Data	Output		
TX_CLK	Transmit Clock or Reference Clock	Output		
TX_EN	Transmit Enable	Output		
TX_ER	Transmit Coding Error	Output		

**Table 5-1.** Signal Description List

Signal Name	Function	Type	Active Level	Comments
<b>External Bus Interface - HEBI</b>				
ADDR0 - ADDR23	Address Bus	Output		
CAS	Column Signal	Output	Low	
DATA0 - DATA15	Data Bus	I/O		
NCS0 - NCS3	Chip Select	Output	Low	
NRD	Read Signal	Output	Low	
NWAIT	External Wait Signal	Input	Low	
NWE0	Write Enable 0	Output	Low	
NWE1	Write Enable 1	Output	Low	
NWE3	Write Enable 3	Output	Low	
RAS	Row Signal	Output	Low	
SDA10	SDRAM Address 10 Line	Output		
SDCK	SDRAM Clock	Output		
SDCKE	SDRAM Clock Enable	Output		
SDCS0	SDRAM Chip Select	Output	Low	
SDWE	SDRAM Write Enable	Output	Low	
<b>General Purpose Input/Output 2 - GPIOA, GPIOB, GPIOC</b>				
P0 - P31	Parallel I/O Controller GPIOA	I/O		
P0 - P31	Parallel I/O Controller GPIOB	I/O		
P0 - P5	Parallel I/O Controller GPIOC	I/O		
P0 - P31	Parallel I/O Controller GPIOX	I/O		
<b>Serial Peripheral Interface - SPI0, SPI1</b>				
MISO	Master In Slave Out	I/O		
MOSI	Master Out Slave In	I/O		
NPCS0 - NPCS3	SPI Peripheral Chip Select	I/O	Low	
SCK	Clock	Output		
<b>Synchronous Serial Controller - SSC</b>				
RX_CLOCK	SSC Receive Clock	I/O		

**Table 5-1.** Signal Description List

Signal Name	Function	Type	Active Level	Comments
RX_DATA	SSC Receive Data	Input		
RX_FRAME_SYNC	SSC Receive Frame Sync	I/O		
TX_CLOCK	SSC Transmit Clock	I/O		
TX_DATA	SSC Transmit Data	Output		
TX_FRAME_SYNC	SSC Transmit Frame Sync	I/O		
<b>Timer/Counter - TIMER</b>				
A0	Channel 0 Line A	I/O		
A1	Channel 1 Line A	I/O		
A2	Channel 2 Line A	I/O		
B0	Channel 0 Line B	I/O		
B1	Channel 1 Line B	I/O		
B2	Channel 2 Line B	I/O		
CLK0	Channel 0 External Clock Input	Input		
CLK1	Channel 1 External Clock Input	Input		
CLK2	Channel 2 External Clock Input	Input		
<b>Two-wire Interface - TWI</b>				
SCL	Serial Clock	I/O		
SDA	Serial Data	I/O		
<b>Universal Synchronous Asynchronous Receiver Transmitter - USART0, USART1, USART2, USART3</b>				
CLK	Clock	I/O		
CTS	Clear To Send	Input		
DCD	Data Carrier Detect			Only USART1
DSR	Data Set Ready			Only USART1
DTR	Data Terminal Ready			Only USART1
RI	Ring Indicator			Only USART1
RTS	Request To Send	Output		
RXD	Receive Data	Input		
TXD	Transmit Data	Output		

**Table 5-1.** Signal Description List

Signal Name	Function	Type	Active Level	Comments
<b>Analog to Digital Converter - ADC</b>				
AD0 - AD7	Analog input pins	Analog input		
ADVREF	Analog positive reference voltage input	Analog input		2.6 to 3.6V
<b>Pulse Width Modulator - PWM</b>				
PWM0 - PWM6	PWM Output Pins	Output		
<b>Universal Serial Bus Device - USB</b>				
DDM	USB Device Port Data -	Analog		
DDP	USB Device Port Data +	Analog		
VBUS	USB VBUS Monitor and OTG Negotiation	Analog Input		
USBID	ID Pin of the USB Bus	Input		
USB_VBOF	USB VBUS On/off: bus power control port	output		
<b>Audio Bitstream DAC (ABDAC)</b>				
DATA0-DATA1	D/A Data out	Output		
DATAN0-DATAN1	D/A Data inverted out	Output		

## 6. Power Considerations

### 6.1 Power Supplies

The AT32UC3A has several types of power supply pins:

- **VDDIO:** Powers I/O lines. Voltage is 3.3V nominal.
- **VDDANA:** Powers the ADC Voltage is 3.3V nominal.
- **VDDIN:** Input voltage for the voltage regulator. Voltage is 3.3V nominal.
- **VDDCORE:** Powers the core, memories, and peripherals. Voltage is 1.8V nominal.
- **VDDPLL:** Powers the PLL. Voltage is 1.8V nominal.

The ground pins GND are common to VDDCORE, VDDIO, VDDPLL. The ground pin for VDDANA is GNDANA.

Refer to ["Power Consumption" on page 767](#) for power consumption on the various supply pins.

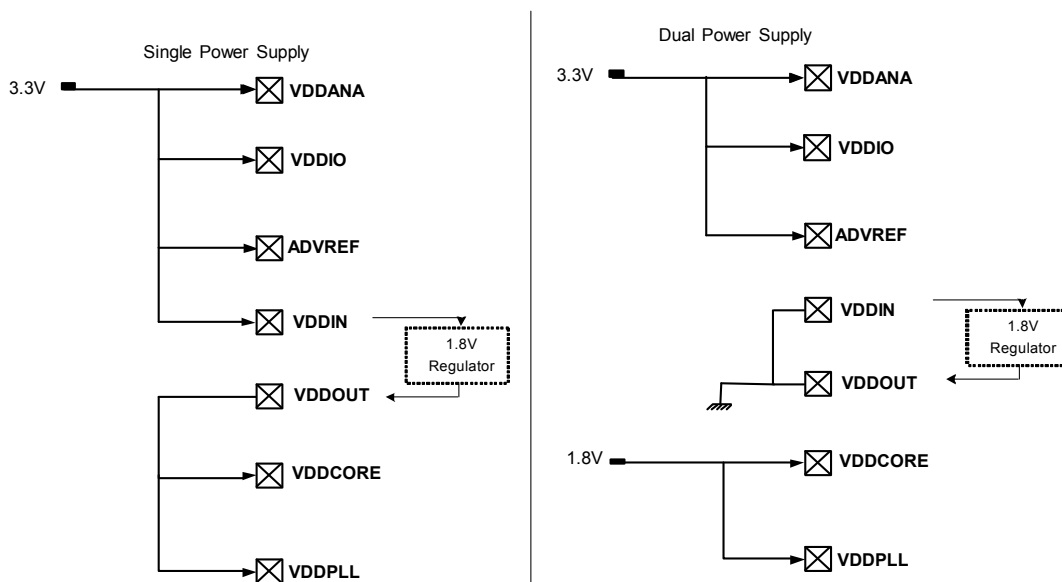

## 6.2 Voltage Regulator

### 6.2.1 Single Power Supply

The AT32UC3A embeds a voltage regulator that converts from 3.3V to 1.8V. The regulator takes its input voltage from VDDIN, and supplies the output voltage on VDDOUT. VDDOUT should be externally connected to the 1.8V domains.

Adequate input supply decoupling is mandatory for VDDIN in order to improve startup stability and reduce source voltage drop. Two input decoupling capacitors must be placed close to the chip.

Adequate output supply decoupling is mandatory for VDDOUT to reduce ripple and avoid oscillations. The best way to achieve this is to use two capacitors in parallel between VDDOUT and GND as close to the chip as possible

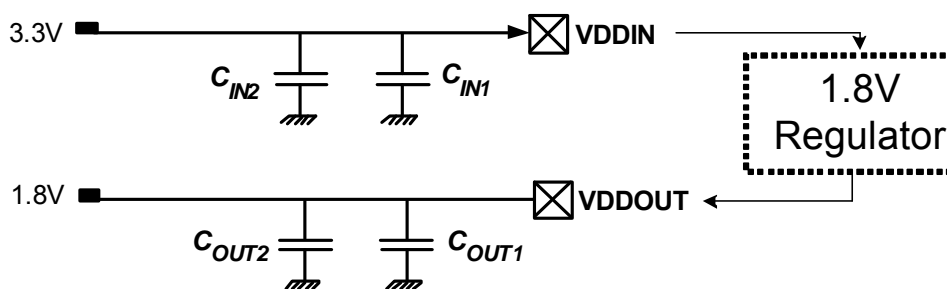

Refer to [Section 38.3 on page 765](#) for decoupling capacitors values and regulator characteristics

### 6.2.2 Dual Power Supply

In case of dual power supply, VDDIN and VDDOUT should be connected to ground to prevent from leakage current.

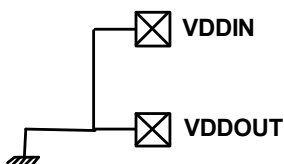

### 6.3 Analog-to-Digital Converter (A.D.C) reference.

The ADC reference (ADVREF) must be provided from an external source. Two decoupling capacitors must be used to insure proper decoupling.

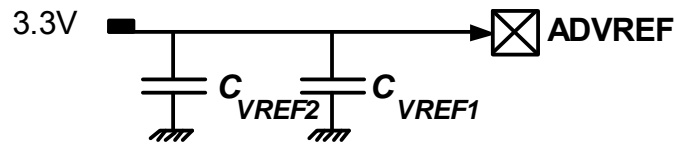

Refer to [Section 38.4 on page 765](#) for decoupling capacitors values and electrical characteristics.

In case ADC is not used, the ADVREF pin should be connected to GND to avoid extra consumption.

## 7. Package and Pinout

The device pins are multiplexed with peripheral functions as described in ["Peripheral Multiplexing on I/O lines"](#) on page 45.

**Figure 7-1.** TQFP100 Pinout

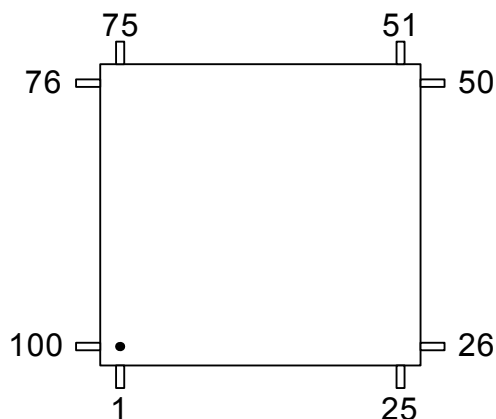

**Table 7-1.** TQFP100 Package Pinout

1	PB20	26	PA05	51	PA21	76	PB08
2	PB21	27	PA06	52	PA22	77	PB09
3	PB22	28	PA07	53	PA23	78	PB10
4	VDDIO	29	PA08	54	PA24	79	VDDIO
5	GND	30	PA09	55	PA25	80	GND
6	PB23	31	PA10	56	PA26	81	PB11
7	PB24	32	N/C	57	PA27	82	PB12
8	PB25	33	PA11	58	PA28	83	PA29
9	PB26	34	VDDCORE	59	VDDANA	84	PA30
10	PB27	35	GND	60	ADVREF	85	PC02
11	VDDOUT	36	PA12	61	GNDANA	86	PC03
12	VDDIN	37	PA13	62	VDDPLL	87	PB13
13	GND	38	VDDCORE	63	PC00	88	PB14
14	PB28	39	PA14	64	PC01	89	TMS
15	PB29	40	PA15	65	PB00	90	TCK
16	PB30	41	PA16	66	PB01	91	TDO
17	PB31	42	PA17	67	VDDIO	92	TDI
18	RESET_N	43	PA18	68	VDDIO	93	PC04
19	PA00	44	PA19	69	GND	94	PC05
20	PA01	45	PA20	70	PB02	95	PB15
21	GND	46	VBUS	71	PB03	96	PB16
22	VDDCORE	47	VDDIO	72	PB04	97	VDDCORE



**Table 7-1.** TQFP100 Package Pinout

23	PA02	48	DM	73	PB05	98	PB17
24	PA03	49	DP	74	PB06	99	PB18
25	PA04	50	GND	75	PB07	100	PB19

**Figure 7-2.** LQFP144 Pinout

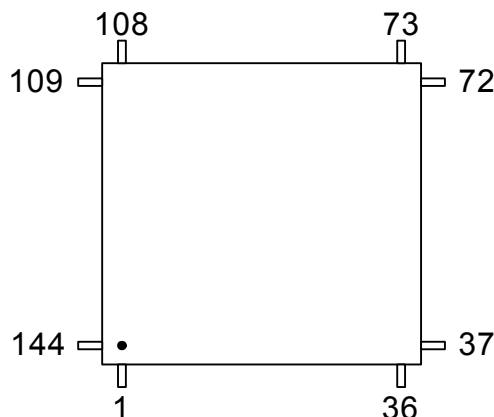

**Table 7-2.** VQFP144 Package Pinout

1	PX00	37	GND	73	PA21	109	GND
2	PX01	38	PX10	74	PA22	110	PX30
3	PB20	39	PA05	75	PA23	111	PB08
4	PX02	40	PX11	76	PA24	112	PX31
5	PB21	41	PA06	77	PA25	113	PB09
6	PB22	42	PX12	78	PA26	114	PX32
7	VDDIO	43	PA07	79	PA27	115	PB10
8	GND	44	PX13	80	PA28	116	VDDIO
9	PB23	45	PA08	81	VDDANA	117	GND
10	PX03	46	PX14	82	ADVREF	118	PX33
11	PB24	47	PA09	83	GNDANA	119	PB11
12	PX04	48	PA10	84	VDDPLL	120	PX34
13	PB25	49	N/C	85	PC00	121	PB12
14	PB26	50	PA11	86	PC01	122	PA29
15	PB27	51	VDDCORE	87	PX20	123	PA30
16	VDDOUT	52	GND	88	PB00	124	PC02
17	VDDIN	53	PA12	89	PX21	125	PC03
18	GND	54	PA13	90	PB01	126	PB13
19	PB28	55	VDDCORE	91	PX22	127	PB14
20	PB29	56	PA14	92	VDDIO	128	TMS
21	PB30	57	PA15	93	VDDIO	129	TCK

**Table 7-2.** VQFP144 Package Pinout

22	PB31	58	PA16	94	GND	130	TDO
23	RESET_N	59	PX15	95	PX23	131	TDI
24	PX05	60	PA17	96	PB02	132	PC04
25	PA00	61	PX16	97	PX24	133	PC05
26	PX06	62	PA18	98	PB03	134	PB15
27	PA01	63	PX17	99	PX25	135	PX35
28	GND	64	PA19	100	PB04	136	PB16
29	VDDCORE	65	PX18	101	PX26	137	PX36
30	PA02	66	PA20	102	PB05	138	VDDCORE
31	PX07	67	PX19	103	PX27	139	PB17
32	PA03	68	VBUS	104	PB06	140	PX37
33	PX08	69	VDDIO	105	PX28	141	PB18
34	PA04	70	DM	106	PB07	142	PX38
35	PX09	71	DP	107	PX29	143	PB19
36	VDDIO	72	GND	108	VDDIO	144	PX39

**Figure 7-3.** BGA144 Pinout

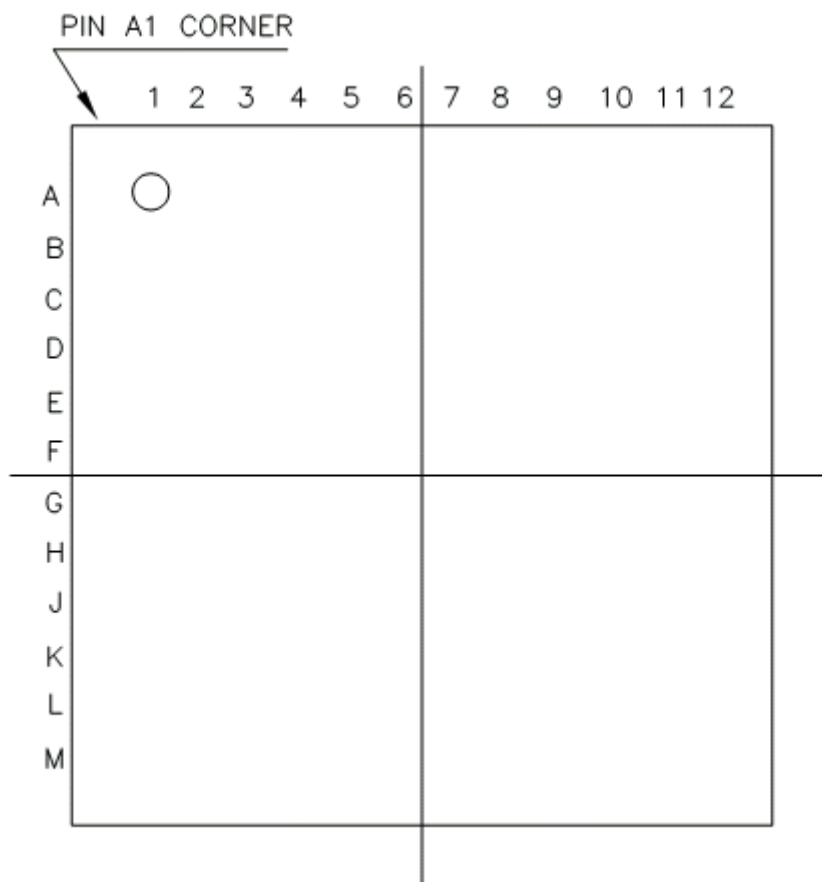

**Table 7-3.** BGA144 Package Pinout A1..M8

	1	2	3	4	5	6	7	8
<b>A</b>	VDDIO	PB07	PB05	PB02	PB03	PB01	PC00	PA28
<b>B</b>	PB08	GND	PB06	PB04	VDDIO	PB00	PC01	VDDPLL
<b>C</b>	PB09	PX33	PA29	PC02	PX28	PX26	PX22	PX21
<b>D</b>	PB11	PB13	PB12	PX30	PX29	PX25	PX24	PX20
<b>E</b>	PB10	VDDIO	PX32	PX31	VDDIO	PX27	PX23	VDDANA
<b>F</b>	PA30	PB14	PX34	PB16	TCK	GND	GND	PX16
<b>G</b>	TMS	PC03	PX36	PX35	PX37	GND	GND	PA16
<b>H</b>	TDO	VDDCORE	PX38	PX39	VDDIO	PA01	PA10	VDDCORE
<b>J</b>	TDI	PB17	PB15	PX00	PX01	PA00	PA03	PA04
<b>K</b>	PC05	PC04	PB19	PB20	PX02	PB29	PB30	PA02
<b>L</b>	PB21	GND	PB18	PB24	VDDOUT	PX04	PB31	VDDIN
<b>M</b>	PB22	PB23	PB25	PB26	PX03	PB27	PB28	RESET_N

**Table 7-4.** BGA144 Package Pinout A9..M12

	9	10	11	12
<b>A</b>	PA26	PA25	PA24	PA23
<b>B</b>	PA27	PA21	GND	PA22
<b>C</b>	ADVREF	GNDANA	PX19	PA19
<b>D</b>	PA18	PA20	DP	DM
<b>E</b>	PX18	PX17	VDDIO	VBUS
<b>F</b>	PA17	PX15	PA15	PA14
<b>G</b>	PA13	PA12	PA11	NC
<b>H</b>	PX11	PA08	VDDCORE	VDDCORE
<b>J</b>	PX14	PA07	PX13	PA09
<b>K</b>	PX08	GND	PA05	PX12
<b>L</b>	PX06	PX10	GND	PA06
<b>M</b>	PX05	PX07	PX09	VDDIO

Note: NC is not connected.

## 8. I/O Line Considerations

### 8.1 JTAG pins

TMS, TDI and TCK have pull-up resistors. TDO is an output, driven at up to VDDIO, and has no pull-up resistor.

### 8.2 RESET\_N pin

The RESET\_N pin is a schmitt input and integrates a permanent pull-up resistor to VDDIO. As the product integrates a power-on reset cell, the RESET\_N pin can be left unconnected in case no reset from the system needs to be applied to the product.

### 8.3 TWI pins

When these pins are used for TWI, the pins are open-drain outputs with slew-rate limitation and inputs with inputs with spike-filtering. When used as GPIO-pins or used for other peripherals, the pins have the same characteristics as PIO pins.

### 8.4 GPIO pins

All the I/O lines integrate a programmable pull-up resistor. Programming of this pull-up resistor is performed independently for each I/O line through the GPIO Controllers. After reset, I/O lines default as inputs with pull-up resistors disabled, except when indicated otherwise in the column “Reset State” of the GPIO Controller multiplexing tables.

## 9. Processor and Architecture

This chapter gives an overview of the AVR32UC CPU. AVR32UC is an implementation of the AVR32 architecture. A summary of the programming model, instruction set and MPU is presented. For further details, see the *AVR32 Architecture Manual* and the *AVR32UC Technical Reference Manual*.

### 9.1 AVR32 Architecture

AVR32 is a new, high-performance 32-bit RISC microprocessor architecture, designed for cost-sensitive embedded applications, with particular emphasis on low power consumption and high code density. In addition, the instruction set architecture has been tuned to allow a variety of microarchitectures, enabling the AVR32 to be implemented as low-, mid- or high-performance processors. AVR32 extends the AVR family into the world of 32- and 64-bit applications.

Through a quantitative approach, a large set of industry recognized benchmarks has been compiled and analyzed to achieve the best code density in its class. In addition to lowering the memory requirements, a compact code size also contributes to the core's low power characteristics. The processor supports byte and half-word data types without penalty in code size and performance.

Memory load and store operations are provided for byte, half-word, word and double word data with automatic sign- or zero extension of half-word and byte data. The C-compiler is closely linked to the architecture and is able to exploit code optimization features, both for size and speed.

In order to reduce code size to a minimum, some instructions have multiple addressing modes. As an example, instructions with immediates often have a compact format with a smaller immediate, and an extended format with a larger immediate. In this way, the compiler is able to use the format giving the smallest code size.

Another feature of the instruction set is that frequently used instructions, like add, have a compact format with two operands as well as an extended format with three operands. The larger format increases performance, allowing an addition and a data move in the same instruction in a single cycle. Load and store instructions have several different formats in order to reduce code size and speed up execution.

The register file is organized as sixteen 32-bit registers and includes the Program Counter, the Link Register, and the Stack Pointer. In addition, register R12 is designed to hold return values from function calls and is used implicitly by some instructions.

### 9.2 The AVR32UC CPU

The AVR32 UC CPU targets low- and medium-performance applications, and provides an advanced OCD system, no caches, and a Memory Protection Unit (MPU). Java acceleration hardware is not implemented.

AVR32 UC provides three memory interfaces, one High Speed Bus master for instruction fetch, one High Speed Bus master for data access, and one High Speed Bus slave interface allowing other bus masters to access data RAMs internal to the CPU. Keeping data RAMs internal to the CPU allows fast access to the RAMs, reduces latency and guarantees deterministic timing. Also, power consumption is reduced by not needing a full High Speed Bus access for memory accesses. A dedicated data RAM interface is provided for communicating with the internal data RAMs.



A local bus interface is provided for connecting the CPU to device-specific high-speed systems, such as floating-point units and fast GPIO ports. This local bus has to be enabled by writing the LOCEN bit in the CPUCR system register. The local bus is able to transfer data between the CPU and the local bus slave in a single clock cycle. The local bus has a dedicated memory range allocated to it, and data transfers are performed using regular load and store instructions. Details on which devices that are mapped into the local bus space is given in the device-specific “Peripherals” chapter of this data sheet.

Figure 9-1 on page 22 displays the contents of AVR32UC.

**Figure 9-1.** Overview of the AVR32UC CPU

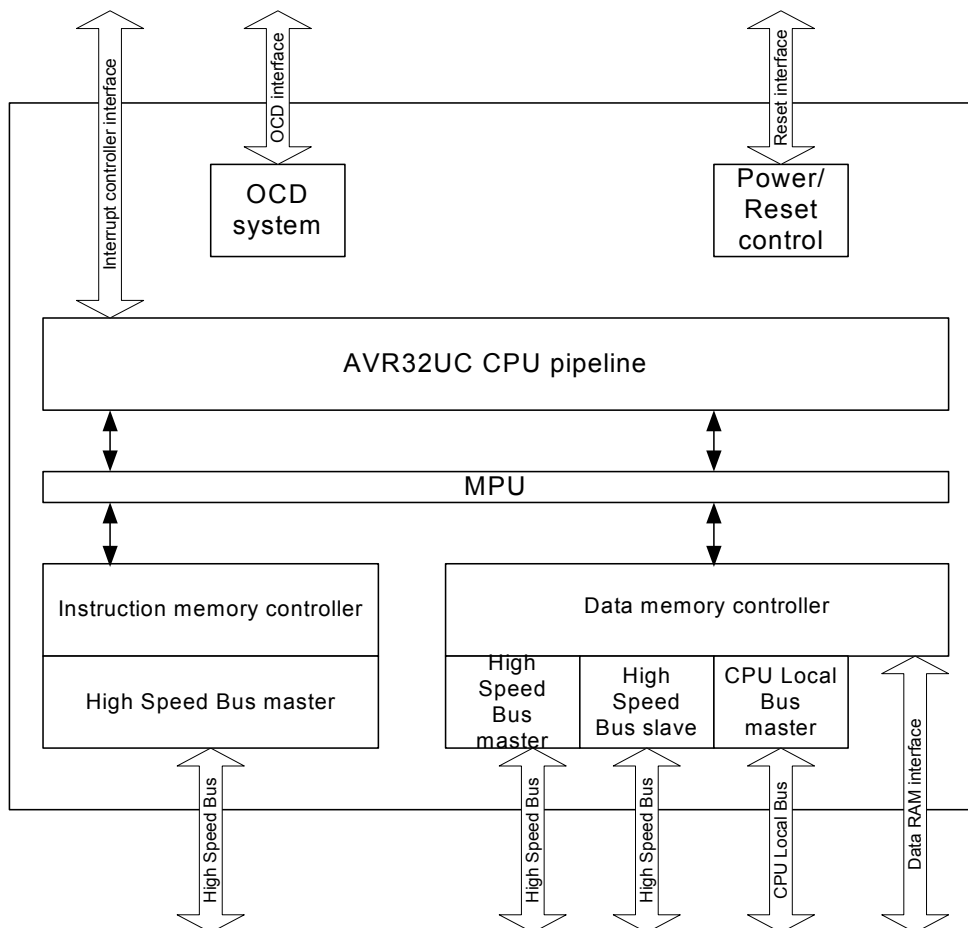

## 9.2.1 Pipeline Overview

AVR32 UC is a pipelined processor with three pipeline stages. There are three pipeline stages, Instruction Fetch (IF), Instruction Decode (ID) and Instruction Execute (EX). The EX stage is split into three parallel subsections, one arithmetic/logic (ALU) section, one multiply (MUL) section and one load/store (LS) section.

Instructions are issued and complete in order. Certain operations require several clock cycles to complete, and in this case, the instruction resides in the ID and EX stages for the required number of clock cycles. Since there is only three pipeline stages, no internal data forwarding is required, and no data dependencies can arise in the pipeline.

Figure 9-2 on page 23 shows an overview of the AVR32 UC pipeline stages.

Figure 9-2. The AVR32UC Pipeline

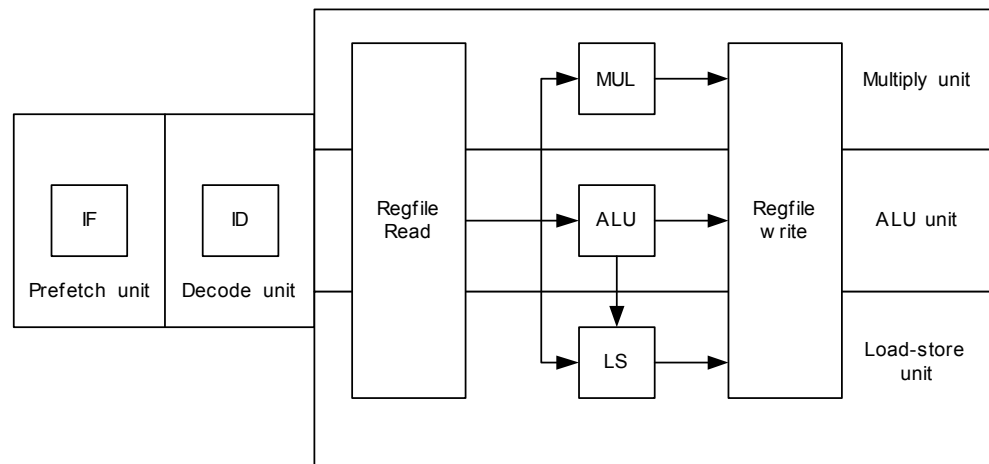

### 9.2.2 AVR32A Microarchitecture Compliance

AVR32UC implements an AVR32A microarchitecture. The AVR32A microarchitecture is targeted at cost-sensitive, lower-end applications like smaller microcontrollers. This microarchitecture does not provide dedicated hardware registers for shadowing of register file registers in interrupt contexts. Additionally, it does not provide hardware registers for the return address registers and return status registers. Instead, all this information is stored on the system stack. This saves chip area at the expense of slower interrupt handling.

Upon interrupt initiation, registers R8-R12 are automatically pushed to the system stack. These registers are pushed regardless of the priority level of the pending interrupt. The return address and status register are also automatically pushed to stack. The interrupt handler can therefore use R8-R12 freely. Upon interrupt completion, the old R8-R12 registers and status register are restored, and execution continues at the return address stored popped from stack.

The stack is also used to store the status register and return address for exceptions and *scall*. Executing the *rete* or *rets* instruction at the completion of an exception or system call will pop this status register and continue execution at the popped return address.

### 9.2.3 Java Support

AVR32UC does not provide Java hardware acceleration.

### 9.2.4 Memory protection

The MPU allows the user to check all memory accesses for privilege violations. If an access is attempted to an illegal memory address, the access is aborted and an exception is taken. The MPU in AVR32UC is specified in the AVR32UC Technical Reference manual.

### 9.2.5 Unaligned reference handling

AVR32UC does not support unaligned accesses, except for doubleword accesses. AVR32UC is able to perform word-aligned *st.d* and *ld.d*. Any other unaligned memory access will cause an address exception. Doubleword-sized accesses with word-aligned pointers will automatically be performed as two word-sized accesses.

The following table shows the instructions with support for unaligned addresses. All other instructions require aligned addresses.

**Table 9-1.** Instructions with unaligned reference support

Instruction	Supported alignment
ld.d	Word
st.d	Word

### 9.2.6 Unimplemented instructions

The following instructions are unimplemented in AVR32UC, and will cause an Unimplemented Instruction Exception if executed:

- All SIMD instructions
- All coprocessor instructions
- retj, incjosp, popjc, pushjc
- tlbr, tlbs, tlbw
- cache

### 9.2.7 CPU and Architecture revision

Two major revisions of the AVR32UC CPU currently exist. The device described in this datasheet uses CPU revision 2.

The Architecture Revision field in the CONFIG0 system register identifies which architecture revision is implemented in a specific device.

AVR32UC CPU revision 2 is fully backward-compatible with revision 1, ie. code compiled for revision 1 is binary-compatible with revision 2 CPUs.



## 9.3 Programming Model

### 9.3.1 Register file configuration

The AVR32UC register file is shown below.

**Figure 9-3.** The AVR32UC Register File

Application		Supervisor		INT0		INT1		INT2		INT3		Exception		NMI	
Bit 31	Bit 0	Bit 31	Bit 0	Bit 31	Bit 0	Bit 31	Bit 0	Bit 31	Bit 0	Bit 31	Bit 0	Bit 31	Bit 0	Bit 31	Bit 0
PC		PC		PC		PC		PC		PC		PC		PC	
LR		LR		LR		LR		LR		LR		LR		LR	
SP_APP		SP_SYS		SP_SYS		SP_SYS		SP_SYS		SP_SYS		SP_SYS		SP_SYS	
R12		R12		R12		R12		R12		R12		R12		R12	
R11		R11		R11		R11		R11		R11		R11		R11	
R10		R10		R10		R10		R10		R10		R10		R10	
R9		R9		R9		R9		R9		R9		R9		R9	
R8		R8		R8		R8		R8		R8		R8		R8	
R7		R7		R7		R7		R7		R7		R7		R7	
R6		R6		R6		R6		R6		R6		R6		R6	
R5		R5		R5		R5		R5		R5		R5		R5	
R4		R4		R4		R4		R4		R4		R4		R4	
R3		R3		R3		R3		R3		R3		R3		R3	
R2		R2		R2		R2		R2		R2		R2		R2	
R1		R1		R1		R1		R1		R1		R1		R1	
R0		R0		R0		R0		R0		R0		R0		R0	
SR		SR		SR		SR		SR		SR		SR		SR	

### 9.3.2 Status register configuration

The Status Register (SR) is split into two halfwords, one upper and one lower, see [Figure 9-4 on page 25](#) and [Figure 9-5 on page 26](#). The lower word contains the C, Z, N, V and Q condition code flags and the R, T and L bits, while the upper halfword contains information about the mode and state the processor executes in. Refer to the *AVR32 Architecture Manual* for details.

**Figure 9-4.** The Status Register High Halfword

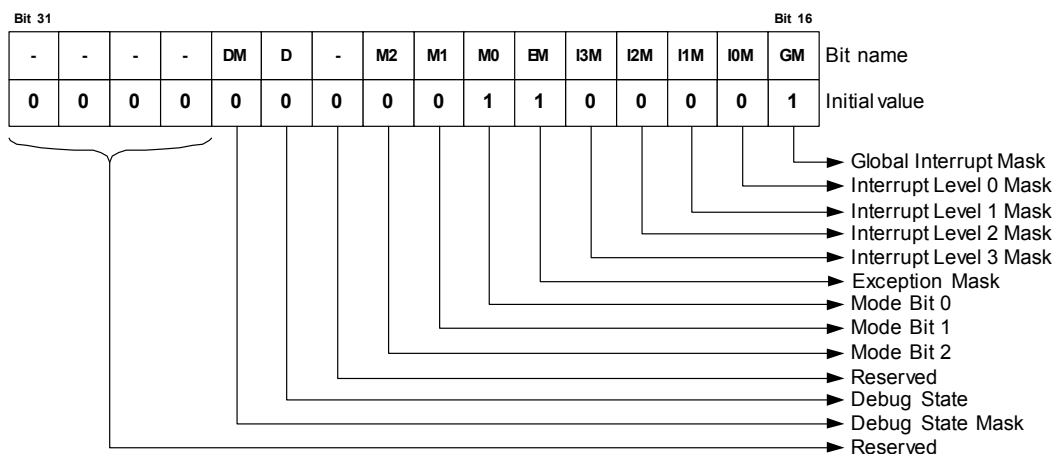

**Figure 9-5.** The Status Register Low Halfword

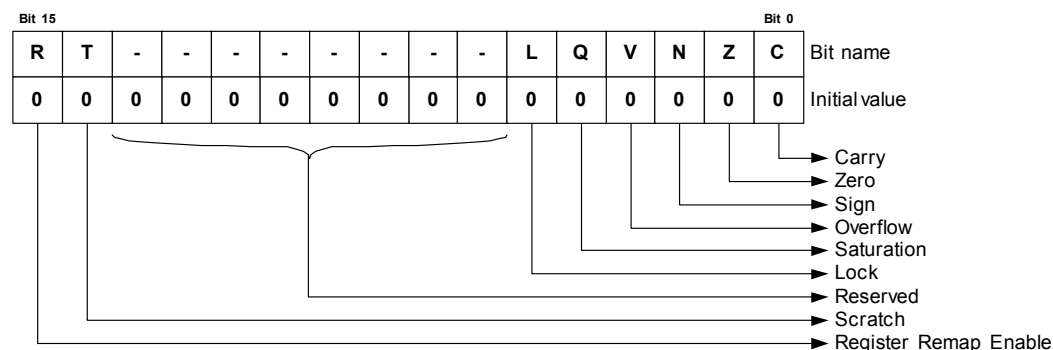

### 9.3.3 Processor States

#### 9.3.3.1 Normal RISC State

The AVR32 processor supports several different execution contexts as shown in [Table 9-2 on page 26](#).

**Table 9-2.** Overview of execution modes, their priorities and privilege levels.

Priority	Mode	Security	Description
1	Non Maskable Interrupt	Privileged	Non Maskable high priority interrupt mode
2	Exception	Privileged	Execute exceptions
3	Interrupt 3	Privileged	General purpose interrupt mode
4	Interrupt 2	Privileged	General purpose interrupt mode
5	Interrupt 1	Privileged	General purpose interrupt mode
6	Interrupt 0	Privileged	General purpose interrupt mode
N/A	Supervisor	Privileged	Runs supervisor calls
N/A	Application	Unprivileged	Normal program execution mode

Mode changes can be made under software control, or can be caused by external interrupts or exception processing. A mode can be interrupted by a higher priority mode, but never by one with lower priority. Nested exceptions can be supported with a minimal software overhead.

When running an operating system on the AVR32, user processes will typically execute in the application mode. The programs executed in this mode are restricted from executing certain instructions. Furthermore, most system registers together with the upper halfword of the status register cannot be accessed. Protected memory areas are also not available. All other operating modes are privileged and are collectively called System Modes. They have full access to all privileged and unprivileged resources. After a reset, the processor will be in supervisor mode.

#### 9.3.3.2 Debug State

The AVR32 can be set in a debug state, which allows implementation of software monitor routines that can read out and alter system information for use during application development. This implies that all system and application registers, including the status registers and program counters, are accessible in debug state. The privileged instructions are also available.

All interrupt levels are by default disabled when debug state is entered, but they can individually be switched on by the monitor routine by clearing the respective mask bit in the status register.

Debug state can be entered as described in the *AVR32UC Technical Reference Manual*.

Debug state is exited by the *retd* instruction.

### 9.3.4 System registers

The system registers are placed outside of the virtual memory space, and are only accessible using the privileged *mfsr* and *mtsr* instructions. The table below lists the system registers specified in the AVR32 architecture, some of which are unused in AVR32UC. The programmer is responsible for maintaining correct sequencing of any instructions following a *mtsr* instruction. For detail on the system registers, refer to the *AVR32UC Technical Reference Manual*.

**Table 9-3.** System Registers

Reg #	Address	Name	Function
0	0	SR	Status Register
1	4	EVBA	Exception Vector Base Address
2	8	ACBA	Application Call Base Address
3	12	CPUCR	CPU Control Register
4	16	ECR	Exception Cause Register
5	20	RSR_SUP	Unused in AVR32UC
6	24	RSR_INT0	Unused in AVR32UC
7	28	RSR_INT1	Unused in AVR32UC
8	32	RSR_INT2	Unused in AVR32UC
9	36	RSR_INT3	Unused in AVR32UC
10	40	RSR_EX	Unused in AVR32UC
11	44	RSR_NMI	Unused in AVR32UC
12	48	RSR_DBG	Return Status Register for Debug Mode
13	52	RAR_SUP	Unused in AVR32UC
14	56	RAR_INT0	Unused in AVR32UC
15	60	RAR_INT1	Unused in AVR32UC
16	64	RAR_INT2	Unused in AVR32UC
17	68	RAR_INT3	Unused in AVR32UC
18	72	RAR_EX	Unused in AVR32UC
19	76	RAR_NMI	Unused in AVR32UC
20	80	RAR_DBG	Return Address Register for Debug Mode
21	84	JECR	Unused in AVR32UC
22	88	JOSP	Unused in AVR32UC
23	92	JAVA_LV0	Unused in AVR32UC
24	96	JAVA_LV1	Unused in AVR32UC
25	100	JAVA_LV2	Unused in AVR32UC

**Table 9-3. System Registers (Continued)**

Reg #	Address	Name	Function
26	104	JAVA_LV3	Unused in AVR32UC
27	108	JAVA_LV4	Unused in AVR32UC
28	112	JAVA_LV5	Unused in AVR32UC
29	116	JAVA_LV6	Unused in AVR32UC
30	120	JAVA_LV7	Unused in AVR32UC
31	124	JTBA	Unused in AVR32UC
32	128	JBCR	Unused in AVR32UC
33-63	132-252	Reserved	Reserved for future use
64	256	CONFIG0	Configuration register 0
65	260	CONFIG1	Configuration register 1
66	264	COUNT	Cycle Counter register
67	268	COMPARE	Compare register
68	272	TLBEHI	Unused in AVR32UC
69	276	TLBELO	Unused in AVR32UC
70	280	PTBR	Unused in AVR32UC
71	284	TLBEAR	Unused in AVR32UC
72	288	MMUCR	Unused in AVR32UC
73	292	TLBARLO	Unused in AVR32UC
74	296	TLBARHI	Unused in AVR32UC
75	300	PCCNT	Unused in AVR32UC
76	304	PCNT0	Unused in AVR32UC
77	308	PCNT1	Unused in AVR32UC
78	312	PCCR	Unused in AVR32UC
79	316	BEAR	Bus Error Address Register
80	320	MPUAR0	MPU Address Register region 0
81	324	MPUAR1	MPU Address Register region 1
82	328	MPUAR2	MPU Address Register region 2
83	332	MPUAR3	MPU Address Register region 3
84	336	MPUAR4	MPU Address Register region 4
85	340	MPUAR5	MPU Address Register region 5
86	344	MPUAR6	MPU Address Register region 6
87	348	MPUAR7	MPU Address Register region 7
88	352	MPUPSR0	MPU Privilege Select Register region 0
89	356	MPUPSR1	MPU Privilege Select Register region 1
90	360	MPUPSR2	MPU Privilege Select Register region 2
91	364	MPUPSR3	MPU Privilege Select Register region 3

**Table 9-3.** System Registers (Continued)

Reg #	Address	Name	Function
92	368	MPUPSR4	MPU Privilege Select Register region 4
93	372	MPUPSR5	MPU Privilege Select Register region 5
94	376	MPUPSR6	MPU Privilege Select Register region 6
95	380	MPUPSR7	MPU Privilege Select Register region 7
96	384	MPUCRA	Unused in this version of AVR32UC
97	388	MPUCRB	Unused in this version of AVR32UC
98	392	MPUBRA	Unused in this version of AVR32UC
99	396	MPUBRB	Unused in this version of AVR32UC
100	400	MPUAPRA	MPU Access Permission Register A
101	404	MPUAPRB	MPU Access Permission Register B
102	408	MPUCR	MPU Control Register
103-191	412-764	Reserved	Reserved for future use
192-255	768-1020	IMPL	IMPLEMENTATION DEFINED

## 9.4 Exceptions and Interrupts

AVR32UC incorporates a powerful exception handling scheme. The different exception sources, like Illegal Op-code and external interrupt requests, have different priority levels, ensuring a well-defined behavior when multiple exceptions are received simultaneously. Additionally, pending exceptions of a higher priority class may preempt handling of ongoing exceptions of a lower priority class.

When an event occurs, the execution of the instruction stream is halted, and execution control is passed to an event handler at an address specified in [Table 9-4 on page 32](#). Most of the handlers are placed sequentially in the code space starting at the address specified by EVBA, with four bytes between each handler. This gives ample space for a jump instruction to be placed there, jumping to the event routine itself. A few critical handlers have larger spacing between them, allowing the entire event routine to be placed directly at the address specified by the EVBA-relative offset generated by hardware. All external interrupt sources have autovector interrupt service routine (ISR) addresses. This allows the interrupt controller to directly specify the ISR address as an address relative to EVBA. The autovector offset has 14 address bits, giving an offset of maximum 16384 bytes. The target address of the event handler is calculated as  $(EVBA \mid event\_handler\_offset)$ , not  $(EVBA + event\_handler\_offset)$ , so EVBA and exception code segments must be set up appropriately. The same mechanisms are used to service all different types of events, including external interrupt requests, yielding a uniform event handling scheme.

An interrupt controller does the priority handling of the external interrupts and provides the autovector offset to the CPU.

### 9.4.1 System stack issues

Event handling in AVR32 UC uses the system stack pointed to by the system stack pointer, SP\_SYS, for pushing and popping R8-R12, LR, status register and return address. Since event code may be timing-critical, SP\_SYS should point to memory addresses in the IRAM section, since the timing of accesses to this memory section is both fast and deterministic.

The user must also make sure that the system stack is large enough so that any event is able to push the required registers to stack. If the system stack is full, and an event occurs, the system will enter an UNDEFINED state.

#### 9.4.2 Exceptions and interrupt requests

When an event other than *scall* or debug request is received by the core, the following actions are performed atomically:

1. The pending event will not be accepted if it is masked. The I3M, I2M, I1M, I0M, EM and GM bits in the Status Register are used to mask different events. Not all events can be masked. A few critical events (NMI, Unrecoverable Exception, TLB Multiple Hit and Bus Error) can not be masked. When an event is accepted, hardware automatically sets the mask bits corresponding to all sources with equal or lower priority. This inhibits acceptance of other events of the same or lower priority, except for the critical events listed above. Software may choose to clear some or all of these bits after saving the necessary state if other priority schemes are desired. It is the event source's responsibility to ensure that their events are left pending until accepted by the CPU.
2. When a request is accepted, the Status Register and Program Counter of the current context is stored to the system stack. If the event is an INT0, INT1, INT2 or INT3, registers R8-R12 and LR are also automatically stored to stack. Storing the Status Register ensures that the core is returned to the previous execution mode when the current event handling is completed. When exceptions occur, both the EM and GM bits are set, and the application may manually enable nested exceptions if desired by clearing the appropriate bit. Each exception handler has a dedicated handler address, and this address uniquely identifies the exception source.
3. The Mode bits are set to reflect the priority of the accepted event, and the correct register file bank is selected. The address of the event handler, as shown in Table 9-4, is loaded into the Program Counter.

The execution of the event handler routine then continues from the effective address calculated.

The *rete* instruction signals the end of the event. When encountered, the Return Status Register and Return Address Register are popped from the system stack and restored to the Status Register and Program Counter. If the *rete* instruction returns from INT0, INT1, INT2 or INT3, registers R8-R12 and LR are also popped from the system stack. The restored Status Register contains information allowing the core to resume operation in the previous execution mode. This concludes the event handling.

#### 9.4.3 Supervisor calls

The AVR32 instruction set provides a supervisor mode call instruction. The *scall* instruction is designed so that privileged routines can be called from any context. This facilitates sharing of code between different execution modes. The *scall* mechanism is designed so that a minimal execution cycle overhead is experienced when performing supervisor routine calls from time-critical event handlers.

The *scall* instruction behaves differently depending on which mode it is called from. The behaviour is detailed in the instruction set reference. In order to allow the *scall* routine to return to the correct context, a return from supervisor call instruction, *rets*, is implemented. In the AVR32UC CPU, *scall* and *rets* uses the system stack to store the return address and the status register.

#### 9.4.4 Debug requests

The AVR32 architecture defines a dedicated debug mode. When a debug request is received by the core, Debug mode is entered. Entry into Debug mode can be masked by the DM bit in the

status register. Upon entry into Debug mode, hardware sets the SR[D] bit and jumps to the Debug Exception handler. By default, debug mode executes in the exception context, but with dedicated Return Address Register and Return Status Register. These dedicated registers remove the need for storing this data to the system stack, thereby improving debuggability. The mode bits in the status register can freely be manipulated in Debug mode, to observe registers in all contexts, while retaining full privileges.

Debug mode is exited by executing the *retd* instruction. This returns to the previous context.

#### 9.4.5 Entry points for events

Several different event handler entry points exist. In AVR32 UC, the reset address is 0x8000\_0000. This places the reset address in the boot flash memory area.

TLB miss exceptions and *scall* have a dedicated space relative to EVBA where their event handler can be placed. This speeds up execution by removing the need for a jump instruction placed at the program address jumped to by the event hardware. All other exceptions have a dedicated event routine entry point located relative to EVBA. The handler routine address identifies the exception source directly.

AVR32UC uses the ITLB and DTLB protection exceptions to signal a MPU protection violation. ITLB and DTLB miss exceptions are used to signal that an access address did not map to any of the entries in the MPU. TLB multiple hit exception indicates that an access address did map to multiple TLB entries, signalling an error.

All external interrupt requests have entry points located at an offset relative to EVBA. This autovector offset is specified by an external Interrupt Controller. The programmer must make sure that none of the autovector offsets interfere with the placement of other code. The autovector offset has 14 address bits, giving an offset of maximum 16384 bytes.

Special considerations should be made when loading EVBA with a pointer. Due to security considerations, the event handlers should be located in non-writeable flash memory, or optionally in a privileged memory protection region if an MPU is present.

If several events occur on the same instruction, they are handled in a prioritized way. The priority ordering is presented in Table 9-4. If events occur on several instructions at different locations in the pipeline, the events on the oldest instruction are always handled before any events on any younger instruction, even if the younger instruction has events of higher priority than the oldest instruction. An instruction B is younger than an instruction A if it was sent down the pipeline later than A.

The addresses and priority of simultaneous events are shown in Table 9-4. Some of the exceptions are unused in AVR32 UC since it has no MMU, coprocessor interface or floating-point unit.

**Table 9-4.** Priority and handler addresses for events

Priority	Handler Address	Name	Event source	Stored Return Address
1	0x8000_0000	Reset	External input	Undefined
2	Provided by OCD system	OCD Stop CPU	OCD system	First non-completed instruction
3	EVBA+0x00	Unrecoverable exception	Internal	PC of offending instruction
4	EVBA+0x04	TLB multiple hit	MPU	
5	EVBA+0x08	Bus error data fetch	Data bus	First non-completed instruction
6	EVBA+0x0C	Bus error instruction fetch	Data bus	First non-completed instruction
7	EVBA+0x10	NMI	External input	First non-completed instruction
8	Autovectored	Interrupt 3 request	External input	First non-completed instruction
9	Autovectored	Interrupt 2 request	External input	First non-completed instruction
10	Autovectored	Interrupt 1 request	External input	First non-completed instruction
11	Autovectored	Interrupt 0 request	External input	First non-completed instruction
12	EVBA+0x14	Instruction Address	CPU	PC of offending instruction
13	EVBA+0x50	ITLB Miss	MPU	
14	EVBA+0x18	ITLB Protection	MPU	PC of offending instruction
15	EVBA+0x1C	Breakpoint	OCD system	First non-completed instruction
16	EVBA+0x20	Illegal Opcode	Instruction	PC of offending instruction
17	EVBA+0x24	Unimplemented instruction	Instruction	PC of offending instruction
18	EVBA+0x28	Privilege violation	Instruction	PC of offending instruction
19	EVBA+0x2C	Floating-point	UNUSED	
20	EVBA+0x30	Coprocessor absent	UNUSED	
21	EVBA+0x100	Supervisor call	Instruction	PC(Supervisor Call) +2
22	EVBA+0x34	Data Address (Read)	CPU	PC of offending instruction
23	EVBA+0x38	Data Address (Write)	CPU	PC of offending instruction
24	EVBA+0x60	DTLB Miss (Read)	MPU	
25	EVBA+0x70	DTLB Miss (Write)	MPU	
26	EVBA+0x3C	DTLB Protection (Read)	MPU	PC of offending instruction
27	EVBA+0x40	DTLB Protection (Write)	MPU	PC of offending instruction
28	EVBA+0x44	DTLB Modified	UNUSED	



## 10. Memories

### 10.1 Embedded Memories

- **Internal High-Speed Flash**
  - 512 KBytes (AT32UC3A0512, AT32UC3A1512)
  - 256 KBytes (AT32UC3A0256, AT32UC3A1256)
  - 128 KBytes (AT32UC3A1128, AT32UC3A2128)
    - 0 Wait State Access at up to 33 MHz in Worst Case Conditions
    - 1 Wait State Access at up to 66 MHz in Worst Case Conditions
    - Pipelined Flash Architecture, allowing burst reads from sequential Flash locations, hiding penalty of 1 wait state access
    - Pipelined Flash Architecture typically reduces the cycle penalty of 1 wait state operation to only 15% compared to 0 wait state operation
    - 100 000 Write Cycles, 15-year Data Retention Capability
    - 4 ms Page Programming Time, 8 ms Chip Erase Time
    - Sector Lock Capabilities, Bootloader Protection, Security Bit
    - 32 Fuses, Erased During Chip Erase
    - User Page For Data To Be Preserved During Chip Erase
- **Internal High-Speed SRAM, Single-cycle access at full speed**
  - 64 KBytes (AT32UC3A0512, AT32UC3A0256, AT32UC3A1512, AT32UC3A1256)
  - 32KBytes (AT32UC3A1128)

### 10.2 Physical Memory Map

The system bus is implemented as a bus matrix. All system bus addresses are fixed, and they are never remapped in any way, not even in boot. Note that AVR32 UC CPU uses unsegmented translation, as described in the AVR32 Architecture Manual. The 32-bit physical address space is mapped as follows:

**Table 10-1.** AT32UC3A Physical Memory Map

Device	Start Address	Size					
		AT32UC3A0512	AT32UC3A1512	AT32UC3A0256	AT32UC3A1256	AT32UC3A0128	AT32UC3A1128
Embedded SRAM	0x0000_0000	64 Kbyte	64 Kbyte	64 Kbyte	64 Kbyte	32 Kbyte	32 Kbyte
Embedded Flash	0x8000_0000	512 Kbyte	512 Kbyte	256 Kbyte	256 Kbyte	128 Kbyte	128 Kbyte
EBI SRAM CS0	0xC000_0000	16 Mbyte	-	16 Mbyte	-	16 Mbyte	-
EBI SRAM CS2	0xC800_0000	16 Mbyte	-	16 Mbyte	-	16 Mbyte	-
EBI SRAM CS3	0xCC00_0000	16 Mbyte	-	16 Mbyte	-	16 Mbyte	-
EBI SRAM CS1 /SDRAM CS0	0xD000_0000	128 Mbyte	-	128 Mbyte	-	128 Mbyte	-
USB Configuration	0xE000_0000	64 Kbyte	64 Kbyte	64 Kbyte	64 Kbyte	64 Kbyte	64 Kbyte
HSB-PB Bridge A	0xFFFFE_0000	64 Kbyte	64 Kbyte	64 Kbyte	64 Kbyte	64 Kbyte	64 Kbyte
HSB-PB Bridge B	0xFFFFF_0000	64 Kbyte	64 Kbyte	64 kByte	64 kByte	64 Kbyte	64 Kbyte

**Table 10-2.** Flash Memory Parameters

Part Number	Flash Size (FLASH_PW)	Number of pages (FLASH_P)	Page size (FLASH_W)	General Purpose Fuse bits (FLASH_F)
AT32UC3A0512	512 Kbytes	1024	128 words	32 fuses
AT32UC3A1512	512 Kbytes	1024	128 words	32 fuses
AT32UC3A0256	256 Kbytes	512	128 words	32 fuses
AT32UC3A1256	256 Kbytes	512	128 words	32 fuses
AT32UC3A1128	128 Kbytes	256	128 words	32 fuses
AT32UC3A0128	128 Kbytes	256	128 words	32 fuses

## 10.3 Bus Matrix Connections

Accesses to unused areas returns an error result to the master requesting such an access.

The bus matrix has the several masters and slaves. Each master has its own bus and its own decoder, thus allowing a different memory mapping per master. The master number in the table below can be used to index the HMATRIX control registers. For example, MCFG0 is associated with the CPU Data master interface.

**Table 10-3.** High Speed Bus masters

Master 0	CPU Data
Master 1	CPU Instruction
Master 2	CPU SAB
Master 3	PDCA
Master 4	MACB DMA
Master 5	USBB DMA

Each slave has its own arbiter, thus allowing a different arbitration per slave. The slave number in the table below can be used to index the HMATRIX control registers. For example, SCFG3 is associated with the Internal SRAM Slave Interface.

**Table 10-4.** High Speed Bus slaves

Slave 0	Internal Flash
Slave 1	HSB-PB Bridge 0
Slave 2	HSB-PB Bridge 1
Slave 3	Internal SRAM
Slave 4	USBB DPRAM
Slave 5	EBI

Figure 10-1. HMatrix Master / Slave Connections

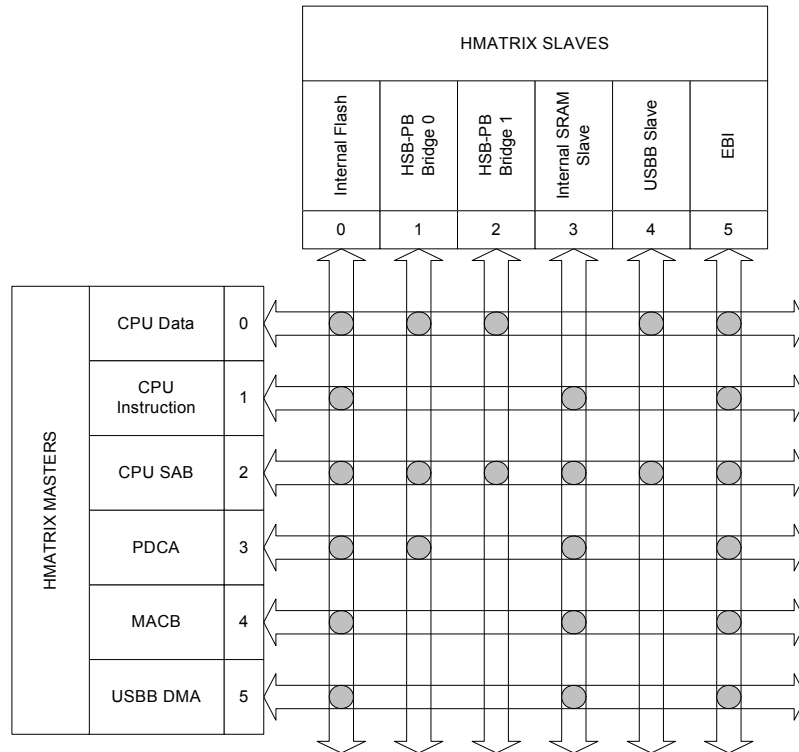

## 11. Fuses Settings

The flash block contains a number of general purpose fuses. Some of these fuses have defined meanings outside the flash controller and are described in this section.

The general purpose fuses are erase by a JTAG chip erase.

### 11.1 Flash General Purpose Fuse Register (FGPFRLO)

**Table 11-1.** FGPFR Register Description

31	30	29	28	27	26	25	24
GPF31	GPF30	GPF29	BODEN		BODHYST	BODLEVEL[5:4]	
23	22	21	20	19	18	17	16
BODLEVEL[3:0]				BOOTPROT			EPFL
15	14	13	12	11	10	9	8
LOCK[15:8]							
7	6	5	4	3	2	1	0
LOCK[7:0]							

#### **BODEN: Brown Out Detector Enable**

**Table 11-2.** BODEN Field Description

BODEN	Description
0x0	BOD disabled
0x1	BOD enabled, BOD reset enabled
0x2	BOD enabled, BOD reset disabled
0x3	BOD disabled

#### **BODHYST: Brown Out Detector Hysteresis**

**Table 11-3.** BODHYST Field Description

BODHYST	Description
0b	The Brown out detector hysteresis is disabled
1b	The Brown out detector hysteresis is enabled.

#### **BODLEVEL: Brown Out Detector Trigger Level**

This controls the voltage trigger level for the Brown out detector. Refer to section [Table 38-6 on page 765](#) for values description. If the BODLEVEL is set higher than VDDCORE and enabled by fuses, the part will be in constant reset. To recover from this situation, apply an external voltage on VDDCORE that is higher than the BOD level and disable the BOD.

**LOCK, EPFL, BOOTPROT**

These are Flash controller fuses and are described in the FLASHC section.

**11.2 Default Fuse Value**

The devices are shipped with the FGPFRLO register value: 0xFC07FFFF:

- GPF31 fuse set to 1b. This fuse is used by the pre-programmed USB bootloader.
- GPF30 fuse set to 1b. This fuse is used by the pre-programmed USB bootloader.
- GPF29 fuse set to 1b. This fuse is used by the pre-programmed USB bootloader.
- BODEN fuses set to 11b. BOD is disabled.
- BODHYST fuse set to 1b. The BOD hysteresis is enabled.
- BODLEVEL fuses set to 000000b. This is the minimum voltage trigger level for BOD.
- BOOTPROT fuses set to 011b. The bootloader protected size is 8 Ko.
- EPFL fuse set to 1b. External privileged fetch is not locked.
- LOCK fuses set to 1111111111111111b. No region locked.

See also the AT32UC3A Bootloader user guide document.

After the JTAG chip erase command, the FGPFRLO register value is 0xFFFFFFFF.

## 12. Peripherals

### 12.1 Peripheral address map

Table 12-1. Peripheral Address Mapping

Address	Peripheral Name	Bus
0xE0000000	USBB USBB Slave Interface - USBB	HSB
0xFFFE0000	USBB USBB Configuration Interface - USBB	PBB
0xFFFE1000	HMATRIX HMATRIX Configuration Interface - HMATRIX	PBB
0xFFFE1400	FLASHC Flash Controller - FLASHC	PBB
0xFFFE1800	MACB MACB Configuration Interface - MACB	PBB
0xFFFE1C00	SMC Static Memory Controller Configuration Interface - SMC	PBB
0xFFFE2000	SDRAMC SDRAM Controller Configuration Interface - SDRAMC	PBB
0xFFFF0000	PDCA Peripheral DMA Interface - PDCA	PBA
0xFFFF0800	INTC Interrupt Controller Interface - INTC	PBA
0xFFFF0C00	PM Power Manager - PM	PBA
0xFFFF0D00	RTC Real Time Clock - RTC	PBA
0xFFFF0D30	WDT WatchDog Timer - WDT	PBA
0xFFFF0D80	EIC External Interrupt Controller - EIC	PBA
0xFFFF1000	GPIO General Purpose IO Controller - GPIO	PBA
0xFFFF1400	USART0 Universal Synchronous Asynchronous Receiver Transmitter - USART0	PBA
0xFFFF1800	USART1 Universal Synchronous Asynchronous Receiver Transmitter - USART1	PBA

**Table 12-1.** Peripheral Address Mapping (Continued)

Address	Peripheral Name	Bus
0xFFFF1C00	USART2 Universal Synchronous Asynchronous Receiver Transmitter - USART2	PBA
0xFFFF2000	USART3 Universal Synchronous Asynchronous Receiver Transmitter - USART3	PBA
0xFFFF2400	SPI0 Serial Peripheral Interface - SPI0	PBA
0xFFFF2800	SPI1 Serial Peripheral Interface - SPI1	PBA
0xFFFF2C00	TWI Two Wire Interface - TWI	PBA
0xFFFF3000	PWM Pulse Width Modulation Controller - PWM	PBA
0xFFFF3400	SSC Synchronous Serial Controller - SSC	PBA
0xFFFF3800	TC Timer/Counter - TC	PBA
0xFFFF3C00	ADC Analog To Digital Converter - ADC	PBA

## 12.2 CPU Local Bus Mapping

Some of the registers in the GPIO module are mapped onto the CPU local bus, in addition to being mapped on the Peripheral Bus. These registers can therefore be reached both by accesses on the Peripheral Bus, and by accesses on the local bus.

Mapping these registers on the local bus allows cycle-deterministic toggling of GPIO pins since the CPU and GPIO are the only modules connected to this bus. Also, since the local bus runs at CPU speed, one write or read operation can be performed per clock cycle to the local bus-mapped GPIO registers.

The following GPIO registers are mapped on the local bus:

**Table 12-2.** Local bus mapped GPIO registers

Port	Register	Mode	Local Bus Address	Access
0	Output Driver Enable Register (ODER)	WRITE	0x4000_0040	Write-only
		SET	0x4000_0044	Write-only
		CLEAR	0x4000_0048	Write-only
		TOGGLE	0x4000_004C	Write-only
	Output Value Register (OVR)	WRITE	0x4000_0050	Write-only
		SET	0x4000_0054	Write-only
		CLEAR	0x4000_0058	Write-only
		TOGGLE	0x4000_005C	Write-only
	Pin Value Register (PVR)	-	0x4000_0060	Read-only
	1	Output Driver Enable Register (ODER)	WRITE	0x4000_0140
SET			0x4000_0144	Write-only
CLEAR			0x4000_0148	Write-only
TOGGLE			0x4000_014C	Write-only
Output Value Register (OVR)		WRITE	0x4000_0150	Write-only
		SET	0x4000_0154	Write-only
		CLEAR	0x4000_0158	Write-only
		TOGGLE	0x4000_015C	Write-only
Pin Value Register (PVR)		-	0x4000_0160	Read-only
2		Output Driver Enable Register (ODER)	WRITE	0x4000_0240
	SET		0x4000_0244	Write-only
	CLEAR		0x4000_0248	Write-only
	TOGGLE		0x4000_024C	Write-only
	Output Value Register (OVR)	WRITE	0x4000_0250	Write-only
		SET	0x4000_0254	Write-only
		CLEAR	0x4000_0258	Write-only
		TOGGLE	0x4000_025C	Write-only
	Pin Value Register (PVR)	-	0x4000_0260	Read-only



**Table 12-2.** Local bus mapped GPIO registers

Port	Register	Mode	Local Bus Address	Access
3	Output Driver Enable Register (ODER)	WRITE	0x4000_0340	Write-only
		SET	0x4000_0344	Write-only
		CLEAR	0x4000_0348	Write-only
		TOGGLE	0x4000_034C	Write-only
	Output Value Register (OVR)	WRITE	0x4000_0350	Write-only
		SET	0x4000_0354	Write-only
		CLEAR	0x4000_0358	Write-only
		TOGGLE	0x4000_035C	Write-only
	Pin Value Register (PVR)	-	0x4000_0360	Read-only

## 12.3 Interrupt Request Signal Map

The various modules may output Interrupt request signals. These signals are routed to the Interrupt Controller (INTC), described in a later chapter. The Interrupt Controller supports up to 64 groups of interrupt requests. Each group can have up to 32 interrupt request signals. All interrupt signals in the same group share the same autovector address and priority level. Refer to the documentation for the individual submodules for a description of the semantics of the different interrupt requests.

The interrupt request signals are connected to the INTC as follows.

**Table 12-3.** Interrupt Request Signal Map

Group	Line	Module	Signal
0	0	AVR32 UC CPU with optional MPU and optional OCD	SYSBLOCK COMPARE
1	0	External Interrupt Controller	EIC 0
	1	External Interrupt Controller	EIC 1
	2	External Interrupt Controller	EIC 2
	3	External Interrupt Controller	EIC 3
	4	External Interrupt Controller	EIC 4
	5	External Interrupt Controller	EIC 5
	6	External Interrupt Controller	EIC 6
	7	External Interrupt Controller	EIC 7
	8	Real Time Counter	RTC
	9	Power Manager	PM
	10	Frequency Meter	FREQM

**Table 12-3. Interrupt Request Signal Map**

2	0	General Purpose Input/Output	GPIO 0
	1	General Purpose Input/Output	GPIO 1
	2	General Purpose Input/Output	GPIO 2
	3	General Purpose Input/Output	GPIO 3
	4	General Purpose Input/Output	GPIO 4
	5	General Purpose Input/Output	GPIO 5
	6	General Purpose Input/Output	GPIO 6
	7	General Purpose Input/Output	GPIO 7
	8	General Purpose Input/Output	GPIO 8
	9	General Purpose Input/Output	GPIO 9
	10	General Purpose Input/Output	GPIO 10
	11	General Purpose Input/Output	GPIO 11
	12	General Purpose Input/Output	GPIO 12
	13	General Purpose Input/Output	GPIO 13
3	0	Peripheral DMA Controller	PDCA 0
	1	Peripheral DMA Controller	PDCA 1
	2	Peripheral DMA Controller	PDCA 2
	3	Peripheral DMA Controller	PDCA 3
	4	Peripheral DMA Controller	PDCA 4
	5	Peripheral DMA Controller	PDCA 5
	6	Peripheral DMA Controller	PDCA 6
	7	Peripheral DMA Controller	PDCA 7
	8	Peripheral DMA Controller	PDCA 8
	9	Peripheral DMA Controller	PDCA 9
	10	Peripheral DMA Controller	PDCA 10
	11	Peripheral DMA Controller	PDCA 11
	12	Peripheral DMA Controller	PDCA 12
	13	Peripheral DMA Controller	PDCA 13
	14	Peripheral DMA Controller	PDCA 14
4	0	Flash Controller	FLASHC
5	0	Universal Synchronous/Asynchronous Receiver/Transmitter	USART0
6	0	Universal Synchronous/Asynchronous Receiver/Transmitter	USART1
7	0	Universal Synchronous/Asynchronous Receiver/Transmitter	USART2
8	0	Universal Synchronous/Asynchronous Receiver/Transmitter	USART3

**Table 12-3.** Interrupt Request Signal Map

9	0	Serial Peripheral Interface	SPI0
10	0	Serial Peripheral Interface	SPI1
11	0	Two-wire Interface	TWI
12	0	Pulse Width Modulation Controller	PWM
13	0	Synchronous Serial Controller	SSC
14	0	Timer/Counter	TC0
	1	Timer/Counter	TC1
	2	Timer/Counter	TC2
15	0	Analog to Digital Converter	ADC
16	0	Ethernet MAC	MACB
17	0	USB 2.0 OTG Interface	USBB
18	0	SDRAM Controller	SDRAMC
19	0	Audio Bitstream DAC	DAC

## 12.4 Clock Connections

### 12.4.1 Timer/Counters

Each Timer/Counter channel can independently select an internal or external clock source for its counter:

**Table 12-4.** Timer/Counter clock connections

Source	Name	Connection
Internal	TIMER_CLOCK1	32 KHz Oscillator
	TIMER_CLOCK2	PBA clock / 2
	TIMER_CLOCK3	PBA clock / 8
	TIMER_CLOCK4	PBA clock / 32
	TIMER_CLOCK5	PBA clock / 128
External	XC0	See <a href="#">Section 12.7</a>
	XC1	
	XC2	

### 12.4.2 USARTs

Each USART can be connected to an internally divided clock:

**Table 12-5.** USART clock connections

USART	Source	Name	Connection
0	Internal	CLK_DIV	PBA clock / 8
1			
2			
3			

## 12.4.3 SPIs

Each SPI can be connected to an internally divided clock:

**Table 12-6.** SPI clock connections

SPI	Source	Name	Connection
0	Internal	CLK_DIV	PBA clock or PBA clock / 32
1			

## 12.5 Nexus OCD AUX port connections

If the OCD trace system is enabled, the trace system will take control over a number of pins, irrespectively of the PIO configuration. Two different OCD trace pin mappings are possible, depending on the configuration of the OCD AXS register. For details, see the AVR32 UC Technical Reference Manual.

**Table 12-7.** Nexus OCD AUX port connections

Pin	AXS=0	AXS=1
EVTI_N	PB19	PA08
MDO[5]	PB16	PA27
MDO[4]	PB14	PA26
MDO[3]	PB13	PA25
MDO[2]	PB12	PA24
MDO[1]	PB11	PA23
MDO[0]	PB10	PA22
EVTO_N	PB20	PB20
MCKO	PB21	PA21
MSEO[1]	PB04	PA07
MSEO[0]	PB17	PA28

## 12.6 PDC handshake signals

The PDC and the peripheral modules communicate through a set of handshake signals. The following table defines the valid settings for the Peripheral Identifier (PID) in the PDC Peripheral Select Register (PSR).

**Table 12-8.** PDC Handshake Signals

PID Value	Peripheral module & direction
0	ADC
1	SSC - RX
2	USART0 - RX
3	USART1 - RX

**Table 12-8.** PDC Handshake Signals

PID Value	Peripheral module & direction
4	USART2 - RX
5	USART3 - RX
6	TWI - RX
7	SPI0 - RX
8	SPI1 - RX
9	SSC - TX
10	USART0 - TX
11	USART1 - TX
12	USART2 - TX
13	USART3 - TX
14	TWI - TX
15	SPI0 - TX
16	SPI1 - TX
17	ABDAC

## 12.7 Peripheral Multiplexing on I/O lines

Each GPIO line can be assigned to one of 3 peripheral functions; A, B or C. The following table define how the I/O lines on the peripherals A, B and C are multiplexed by the GPIO.

**Table 12-9.** GPIO Controller Function Multiplexing

TQFP100	VQFP144	PIN	GPIO Pin	Function A	Function B	Function C
19	25	PA00	GPIO 0	USART0 - RXD	TC - CLK0	
20	27	PA01	GPIO 1	USART0 - TXD	TC - CLK1	
23	30	PA02	GPIO 2	USART0 - CLK	TC - CLK2	
24	32	PA03	GPIO 3	USART0 - RTS	EIM - EXTINT[4]	DAC - DATA[0]
25	34	PA04	GPIO 4	USART0 - CTS	EIM - EXTINT[5]	DAC - DATAN[0]
26	39	PA05	GPIO 5	USART1 - RXD	PWM - PWM[4]	
27	41	PA06	GPIO 6	USART1 - TXD	PWM - PWM[5]	
28	43	PA07	GPIO 7	USART1 - CLK	PM - GCLK[0]	SPI0 - NPCS[3]
29	45	PA08	GPIO 8	USART1 - RTS	SPI0 - NPCS[1]	EIM - EXTINT[7]
30	47	PA09	GPIO 9	USART1 - CTS	SPI0 - NPCS[2]	MACB - WOL
31	48	PA10	GPIO 10	SPI0 - NPCS[0]	EIM - EXTINT[6]	
33	50	PA11	GPIO 11	SPI0 - MISO	USB - USB_ID	
36	53	PA12	GPIO 12	SPI0 - MOSI	USB - USB_VBOF	
37	54	PA13	GPIO 13	SPI0 - SCK		
39	56	PA14	GPIO 14	SSC - TX_FRAME_SYNC	SPI1 - NPCS[0]	EBI - NCS[0]
40	57	PA15	GPIO 15	SSC - TX_CLOCK	SPI1 - SCK	EBI - ADDR[20]

**Table 12-9. GPIO Controller Function Multiplexing**

41	58	PA16	GPIO 16	SSC - TX_DATA	SPI1 - MOSI	EBI - ADDR[21]
42	60	PA17	GPIO 17	SSC - RX_DATA	SPI1 - MISO	EBI - ADDR[22]
43	62	PA18	GPIO 18	SSC - RX_CLOCK	SPI1 - NPCS[1]	MACB - WOL
44	64	PA19	GPIO 19	SSC - RX_FRAME_SYNC	SPI1 - NPCS[2]	
45	66	PA20	GPIO 20	EIM - EXTINT[8]	SPI1 - NPCS[3]	
51	73	PA21	GPIO 21	ADC - AD[0]	EIM - EXTINT[0]	USB - USB_ID
52	74	PA22	GPIO 22	ADC - AD[1]	EIM - EXTINT[1]	USB - USB_VBOF
53	75	PA23	GPIO 23	ADC - AD[2]	EIM - EXTINT[2]	DAC - DATA[1]
54	76	PA24	GPIO 24	ADC - AD[3]	EIM - EXTINT[3]	DAC - DATAN[1]
55	77	PA25	GPIO 25	ADC - AD[4]	EIM - SCAN[0]	EBI - NCS[0]
56	78	PA26	GPIO 26	ADC - AD[5]	EIM - SCAN[1]	EBI - ADDR[20]
57	79	PA27	GPIO 27	ADC - AD[6]	EIM - SCAN[2]	EBI - ADDR[21]
58	80	PA28	GPIO 28	ADC - AD[7]	EIM - SCAN[3]	EBI - ADDR[22]
83	122	PA29	GPIO 29	TWI - SDA	USART2 - RTS	
84	123	PA30	GPIO 30	TWI - SCL	USART2 - CTS	
65	88	PB00	GPIO 32	MACB - TX_CLK	USART2 - RTS	USART3 - RTS
66	90	PB01	GPIO 33	MACB - TX_EN	USART2 - CTS	USART3 - CTS
70	96	PB02	GPIO 34	MACB - TXD[0]	DAC - DATA[0]	
71	98	PB03	GPIO 35	MACB - TXD[1]	DAC - DATAN[0]	
72	100	PB04	GPIO 36	MACB - CRS	USART3 - CLK	EBI - NCS[3]
73	102	PB05	GPIO 37	MACB - RXD[0]	DAC - DATA[1]	
74	104	PB06	GPIO 38	MACB - RXD[1]	DAC - DATAN[1]	
75	106	PB07	GPIO 39	MACB - RX_ER		
76	111	PB08	GPIO 40	MACB - MDC		
77	113	PB09	GPIO 41	MACB - MDIO		
78	115	PB10	GPIO 42	MACB - TXD[2]	USART3 - RXD	EBI - SDCK
81	119	PB11	GPIO 43	MACB - TXD[3]	USART3 - TXD	EBI - SDCKE
82	121	PB12	GPIO 44	MACB - TX_ER	TC - CLK0	EBI - RAS
87	126	PB13	GPIO 45	MACB - RXD[2]	TC - CLK1	EBI - CAS
88	127	PB14	GPIO 46	MACB - RXD[3]	TC - CLK2	EBI - SDWE
95	134	PB15	GPIO 47	MACB - RX_DV		
96	136	PB16	GPIO 48	MACB - COL	USB - USB_ID	EBI - SDA10
98	139	PB17	GPIO 49	MACB - RX_CLK	USB - USB_VBOF	EBI - ADDR[23]
99	141	PB18	GPIO 50	MACB - SPEED	ADC - TRIGGER	PWM - PWM[6]
100	143	PB19	GPIO 51	PWM - PWM[0]	PM - GCLK[0]	EIM - SCAN[4]
1	3	PB20	GPIO 52	PWM - PWM[1]	PM - GCLK[1]	EIM - SCAN[5]
2	5	PB21	GPIO 53	PWM - PWM[2]	PM - GCLK[2]	EIM - SCAN[6]
3	6	PB22	GPIO 54	PWM - PWM[3]	PM - GCLK[3]	EIM - SCAN[7]
6	9	PB23	GPIO 55	TC - A0	USART1 - DCD	

**Table 12-9. GPIO Controller Function Multiplexing**

7	11	PB24	GPIO 56	TC - B0	USART1 - DSR	
8	13	PB25	GPIO 57	TC - A1	USART1 - DTR	
9	14	PB26	GPIO 58	TC - B1	USART1 - RI	
10	15	PB27	GPIO 59	TC - A2	PWM - PWM[4]	
14	19	PB28	GPIO 60	TC - B2	PWM - PWM[5]	
15	20	PB29	GPIO 61	USART2 - RXD	PM - GCLK[1]	EBI - NCS[2]
16	21	PB30	GPIO 62	USART2 - TXD	PM - GCLK[2]	EBI - SDCS
17	22	PB31	GPIO 63	USART2 - CLK	PM - GCLK[3]	EBI - NWAIT
63	85	PC00	GPIO 64			
64	86	PC01	GPIO 65			
85	124	PC02	GPIO 66			
86	125	PC03	GPIO 67			
93	132	PC04	GPIO 68			
94	133	PC05	GPIO 69			
	1	PX00	GPIO 100	EBI - DATA[10]	USART0 - RXD	
	2	PX01	GPIO 99	EBI - DATA[9]	USART0 - TXD	
	4	PX02	GPIO 98	EBI - DATA[8]	USART0 - CTS	
	10	PX03	GPIO 97	EBI - DATA[7]	USART0 - RTS	
	12	PX04	GPIO 96	EBI - DATA[6]	USART1 - RXD	
	24	PX05	GPIO 95	EBI - DATA[5]	USART1 - TXD	
	26	PX06	GPIO 94	EBI - DATA[4]	USART1 - CTS	
	31	PX07	GPIO 93	EBI - DATA[3]	USART1 - RTS	
	33	PX08	GPIO 92	EBI - DATA[2]	USART3 - RXD	
	35	PX09	GPIO 91	EBI - DATA[1]	USART3 - TXD	
	38	PX10	GPIO 90	EBI - DATA[0]	USART2 - RXD	
	40	PX11	GPIO 109	EBI - NWE1	USART2 - TXD	
	42	PX12	GPIO 108	EBI - NWE0	USART2 - CTS	
	44	PX13	GPIO 107	EBI - NRD	USART2 - RTS	
	46	PX14	GPIO 106	EBI - NCS[1]		TC - A0
	59	PX15	GPIO 89	EBI - ADDR[19]	USART3 - RTS	TC - B0
	61	PX16	GPIO 88	EBI - ADDR[18]	USART3 - CTS	TC - A1
	63	PX17	GPIO 87	EBI - ADDR[17]		TC - B1
	65	PX18	GPIO 86	EBI - ADDR[16]		TC - A2
	67	PX19	GPIO 85	EBI - ADDR[15]	EIM - SCAN[0]	TC - B2
	87	PX20	GPIO 84	EBI - ADDR[14]	EIM - SCAN[1]	TC - CLK0
	89	PX21	GPIO 83	EBI - ADDR[13]	EIM - SCAN[2]	TC - CLK1
	91	PX22	GPIO 82	EBI - ADDR[12]	EIM - SCAN[3]	TC - CLK2
	95	PX23	GPIO 81	EBI - ADDR[11]	EIM - SCAN[4]	
	97	PX24	GPIO 80	EBI - ADDR[10]	EIM - SCAN[5]	

**Table 12-9.** GPIO Controller Function Multiplexing

	99	PX25	GPIO 79	EBI - ADDR[9]	EIM - SCAN[6]	
	101	PX26	GPIO 78	EBI - ADDR[8]	EIM - SCAN[7]	
	103	PX27	GPIO 77	EBI - ADDR[7]	SPI0 - MISO	
	105	PX28	GPIO 76	EBI - ADDR[6]	SPI0 - MOSI	
	107	PX29	GPIO 75	EBI - ADDR[5]	SPI0 - SCK	
	110	PX30	GPIO 74	EBI - ADDR[4]	SPI0 - NPCS[0]	
	112	PX31	GPIO 73	EBI - ADDR[3]	SPI0 - NPCS[1]	
	114	PX32	GPIO 72	EBI - ADDR[2]	SPI0 - NPCS[2]	
	118	PX33	GPIO 71	EBI - ADDR[1]	SPI0 - NPCS[3]	
	120	PX34	GPIO 70	EBI - ADDR[0]	SPI1 - MISO	
	135	PX35	GPIO 105	EBI - DATA[15]	SPI1 - MOSI	
	137	PX36	GPIO 104	EBI - DATA[14]	SPI1 - SCK	
	140	PX37	GPIO 103	EBI - DATA[13]	SPI1 - NPCS[0]	
	142	PX38	GPIO 102	EBI - DATA[12]	SPI1 - NPCS[1]	
	144	PX39	GPIO 101	EBI - DATA[11]	SPI1 - NPCS[2]	

## 12.8 Oscillator Pinout

The oscillators are not mapped to the normal A,B or C functions and their muxings are controlled by registers in the Power Manager (PM). Please refer to the power manager chapter for more information about this.

**Table 12-10.** Oscillator pinout

TQFP100 pin	VQFP144 pin	Pad	Oscillator pin
85	124	PC02	xin0
93	132	PC04	xin1
63	85	PC00	xin32
86	125	PC03	xout0
94	133	PC05	xout1
64	86	PC01	xout32

## 12.9 USART Configuration

**Table 12-11.** USART Supported Mode

	SPI	RS485	ISO7816	IrDA	Modem	Manchester Encoding
USART0	Yes	No	No	No	No	No
USART1	Yes	Yes	Yes	Yes	Yes	Yes
USART2	Yes	No	No	No	No	No
USART3	Yes	No	No	No	No	No



## 12.10 GPIO

The GPIO open drain feature (GPIO ODMER register (Open Drain Mode Enable Register)) is not available for this device.

## 12.11 Peripheral overview

### 12.11.1 External Bus Interface

- **Optimized for Application Memory Space support**
- **Integrates Two External Memory Controllers:**
  - Static Memory Controller
  - SDRAM Controller
- **Optimized External Bus:**
  - 16-bit Data Bus
  - 24-bit Address Bus, Up to 16-Mbytes Addressable
  - Optimized pin multiplexing to reduce latencies on External Memories
- **4 SRAM Chip Selects, 1SDRAM Chip Select:**
  - Static Memory Controller on NCS0
  - SDRAM Controller or Static Memory Controller on NCS1
  - Static Memory Controller on NCS2
  - Static Memory Controller on NCS3

### 12.11.2 Static Memory Controller

- 4 Chip Selects Available
- 64-Mbyte Address Space per Chip Select
- 8-, 16-bit Data Bus
- Word, Halfword, Byte Transfers
- Byte Write or Byte Select Lines
- Programmable Setup, Pulse And Hold Time for Read Signals per Chip Select
- Programmable Setup, Pulse And Hold Time for Write Signals per Chip Select
- Programmable Data Float Time per Chip Select
- Compliant with LCD Module
- External Wait Request
- Automatic Switch to Slow Clock Mode
- Asynchronous Read in Page Mode Supported: Page Size Ranges from 4 to 32 Bytes

### 12.11.3 SDRAM Controller

- **Numerous Configurations Supported**
  - 2K, 4K, 8K Row Address Memory Parts
  - SDRAM with Two or Four Internal Banks
  - SDRAM with 16-bit Data Path
- **Programming Facilities**
  - Word, Half-word, Byte Access
  - Automatic Page Break When Memory Boundary Has Been Reached
  - Multibank Ping-pong Access
  - Timing Parameters Specified by Software
  - Automatic Refresh Operation, Refresh Rate is Programmable
- **Energy-saving Capabilities**
  - Self-refresh, Power-down and Deep Power Modes Supported

- Supports Mobile SDRAM Devices
- Error Detection
  - Refresh Error Interrupt
- SDRAM Power-up Initialization by Software
- CAS Latency of 1, 2, 3 Supported
- Auto Precharge Command Not Used

## 12.11.4 USB Controller

- USB 2.0 Compliant, Full-/Low-Speed (FS/LS) and On-The-Go (OTG), 12 Mbit/s
- 7 Pipes/Endpoints
- 960 bytes of Embedded Dual-Port RAM (DPRAM) for Pipes/Endpoints
- Up to 2 Memory Banks per Pipe/Endpoint (Not for Control Pipe/Endpoint)
- Flexible Pipe/Endpoint Configuration and Management with Dedicated DMA Channels
- On-Chip Transceivers Including Pull-Ups

## 12.11.5 Serial Peripheral Interface

- Supports communication with serial external devices
  - Four chip selects with external decoder support allow communication with up to 15 peripherals
  - Serial memories, such as DataFlash and 3-wire EEPROMs
  - Serial peripherals, such as ADCs, DACs, LCD Controllers, CAN Controllers and Sensors
  - External co-processors
- Master or slave serial peripheral bus interface
  - 8- to 16-bit programmable data length per chip select
  - Programmable phase and polarity per chip select
  - Programmable transfer delays between consecutive transfers and between clock and data per chip select
  - Programmable delay between consecutive transfers
  - Selectable mode fault detection
- Very fast transfers supported
  - Transfers with baud rates up to Peripheral Bus A (PBA) max frequency
  - The chip select line may be left active to speed up transfers on the same device

## 12.11.6 Two-wire Interface

- High speed up to 400kbit/s
- Compatibility with standard two-wire serial memory
- One, two or three bytes for slave address
- Sequential read/write operations

## 12.11.7 USART

- Programmable Baud Rate Generator
- 5- to 9-bit full-duplex synchronous or asynchronous serial communications
  - 1, 1.5 or 2 stop bits in Asynchronous Mode or 1 or 2 stop bits in Synchronous Mode
  - Parity generation and error detection
  - Framing error detection, overrun error detection
  - MSB- or LSB-first
  - Optional break generation and detection
  - By 8 or by-16 over-sampling receiver frequency
  - Hardware handshaking RTS-CTS
  - Receiver time-out and transmitter timeguard
  - Optional Multi-drop Mode with address generation and detection

- Optional Manchester Encoding
- RS485 with driver control signal
- ISO7816, T = 0 or T = 1 Protocols for interfacing with smart cards
  - NACK handling, error counter with repetition and iteration limit
- IrDA modulation and demodulation
  - Communication at up to 115.2 Kbps
- Test Modes
  - Remote Loopback, Local Loopback, Automatic Echo
- SPI Mode
  - Master or Slave
  - Serial Clock Programmable Phase and Polarity
  - SPI Serial Clock (SCK) Frequency up to Internal Clock Frequency PBA/4
- Supports Connection of Two Peripheral DMA Controller Channels (PDC)
  - Offers Buffer Transfer without Processor Intervention

## 12.11.8 Serial Synchronous Controller

- Provides serial synchronous communication links used in audio and telecom applications (with CODECs in Master or Slave Modes, I2S, TDM Buses, Magnetic Card Reader, etc.)
- Contains an independent receiver and transmitter and a common clock divider
- Offers a configurable frame sync and data length
- Receiver and transmitter can be programmed to start automatically or on detection of different event on the frame sync signal
- Receiver and transmitter include a data signal, a clock signal and a frame synchronization signal

## 12.11.9 Timer Counter

- Three 16-bit Timer Counter Channels
- Wide range of functions including:
  - Frequency Measurement
  - Event Counting
  - Interval Measurement
  - Pulse Generation
  - Delay Timing
  - Pulse Width Modulation
  - Up/down Capabilities
- Each channel is user-configurable and contains:
  - Three external clock inputs
  - Five internal clock inputs
  - Two multi-purpose input/output signals
- Two global registers that act on all three TC Channels

## 12.11.10 Pulse Width Modulation Controller

- 7 channels, one 20-bit counter per channel
- Common clock generator, providing Thirteen Different Clocks
  - A Modulo n counter providing eleven clocks
  - Two independent Linear Dividers working on modulo n counter outputs
- Independent channel programming
  - Independent Enable Disable Commands
  - Independent Clock
  - Independent Period and Duty Cycle, with Double Bufferization
  - Programmable selection of the output waveform polarity
  - Programmable center or left aligned output waveform

### 12.11.11 Ethernet 10/100 MAC

- Compatibility with IEEE Standard 802.3
- 10 and 100 Mbits per second data throughput capability
- Full- and half-duplex operations
- MII or RMI interface to the physical layer
- Register Interface to address, data, status and control registers
- DMA Interface, operating as a master on the Memory Controller
- Interrupt generation to signal receive and transmit completion
- 28-byte transmit and 28-byte receive FIFOs
- Automatic pad and CRC generation on transmitted frames
- Address checking logic to recognize four 48-bit addresses
- Support promiscuous mode where all valid frames are copied to memory
- Support physical layer management through MDIO interface control of alarm and update time/calendar data

### 12.11.12 Audio Bitstream DAC

- Digital Stereo DAC
- Oversampled D/A conversion architecture
  - Oversampling ratio fixed 128x
  - FIR equalization filter
  - Digital interpolation filter: Comb4
  - 3rd Order Sigma-Delta D/A converters
- Digital bitstream outputs
- Parallel interface
- Connected to Peripheral DMA Controller for background transfer without CPU intervention

## 13. Power Manager (PM)

Rev: 2.0.0.1

### 13.1 Features

- Controls integrated oscillators and PLLs
- Generates clocks and resets for digital logic
- Supports 2 crystal oscillators 450 kHz-16 MHz
- Supports 2 PLLs 80-240 MHz
- Supports 32 KHz ultra-low power oscillator
- Integrated low-power RC oscillator
- On-the fly frequency change of CPU, HSB, PBA, and PBB clocks
- Sleep modes allow simple disabling of logic clocks, PLLs, and oscillators
- Module-level clock gating through maskable peripheral clocks
- Wake-up from internal or external interrupts
- Generic clocks with wide frequency range provided
- Automatic identification of reset sources
- Controls brownout detector (BOD), RC oscillator, and bandgap voltage reference through control and calibration registers

### 13.2 Description

The Power Manager (PM) controls the oscillators and PLLs, and generates the clocks and resets in the device. The PM controls two fast crystal oscillators, as well as two PLLs, which can multiply the clock from either oscillator to provide higher frequencies. Additionally, a low-power 32 KHz oscillator is used to generate the real-time counter clock for high accuracy real-time measurements. The PM also contains a low-power RC oscillator with fast start-up time, which can be used to clock the digital logic.

The provided clocks are divided into synchronous and generic clocks. The synchronous clocks are used to clock the main digital logic in the device, namely the CPU, and the modules and peripherals connected to the HSB, PBA, and PBB buses. The generic clocks are asynchronous clocks, which can be tuned precisely within a wide frequency range, which makes them suitable for peripherals that require specific frequencies, such as timers and communication modules.

The PM also contains advanced power-saving features, allowing the user to optimize the power consumption for an application. The synchronous clocks are divided into three clock domains, one for the CPU and HSB, one for modules on the PBA bus, and one for modules on the PBB bus. The three clocks can run at different speeds, so the user can save power by running peripherals at a relatively low clock, while maintaining a high CPU performance. Additionally, the clocks can be independently changed on-the-fly, without halting any peripherals. This enables the user to adjust the speed of the CPU and memories to the dynamic load of the application, without disturbing or re-configuring active peripherals.

Each module also has a separate clock, enabling the user to switch off the clock for inactive modules, to save further power. Additionally, clocks and oscillators can be automatically switched off during idle periods by using the sleep instruction on the CPU. The system will return to normal on occurrence of interrupts.

The Power Manager also contains a Reset Controller, which collects all possible reset sources, generates hard and soft resets, and allows the reset source to be identified by software.



13.3 Block Diagram

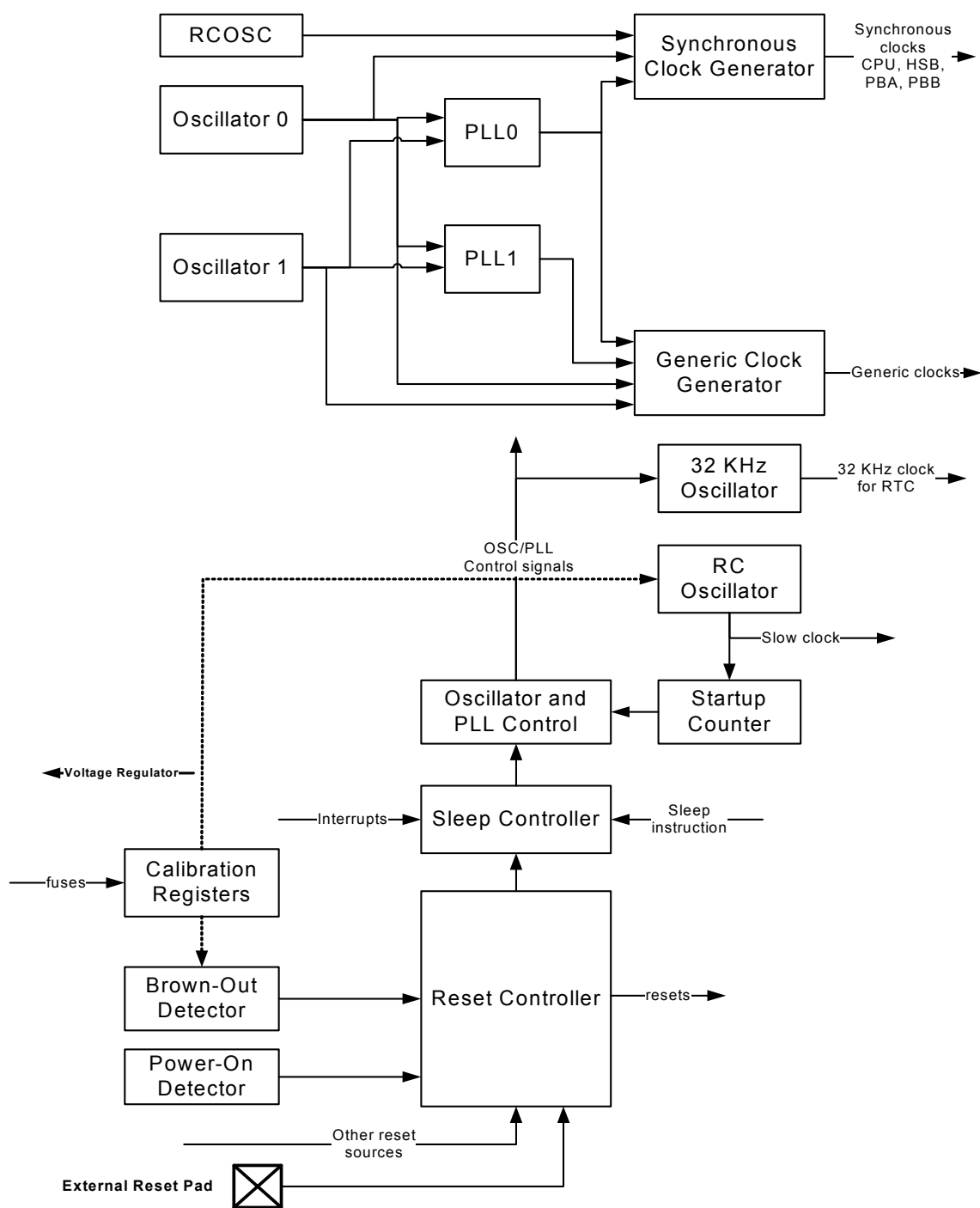

Figure 13-1. Power Manager block diagram

## 13.4 Product Dependencies

### 13.4.1 I/O Lines

The PM provides a number of generic clock outputs, which can be connected to output pins, multiplexed with GPIO lines. The programmer must first program the GPIO controller to assign these pins to their peripheral function. If the I/O pins of the PM are not used by the application, they can be used for other purposes by the GPIO controller.

### 13.4.2 Interrupt

The PM interrupt line is connected to one of the internal sources of the interrupt controller. Using the PM interrupt requires the interrupt controller to be programmed first.

### 13.4.3 Clock implementation

In AT32UC3A, the HSB shares the source clock with the CPU. This means that writing to the HSBDIV and HSBSEL bits in CKSEL has no effect. These bits will always read the same as CPUDIV and CPUSEL.

## 13.5 Functional Description

### 13.5.1 Slow clock

The slow clock is generated from an internal RC oscillator which is always running, except in Static mode. The slow clock can be used for the main clock in the device, as described in "[Synchronous clocks](#)" on page 58. The slow clock is also used for the Watchdog Timer and measuring various delays in the Power Manager.

The RC oscillator has a 3 cycles startup time, and is always available when the CPU is running. The RC oscillator operates at approximately 115 kHz, and can be calibrated to a narrow range by the RCOSCCAL fuses. Software can also change RC oscillator calibration through the use of the RCCR register. Please see the Electrical Characteristics section for details.

RC oscillator can also be used as the RTC clock when crystal accuracy is not required.

### 13.5.2 Oscillator 0 and 1 operation

The two main oscillators are designed to be used with an external 450 kHz to 16 MHz crystal and two biasing capacitors, as shown in [Figure 13-2](#). Oscillator 0 can be used for the main clock in the device, as described in "[Synchronous clocks](#)" on page 58. Both oscillators can be used as source for the generic clocks, as described in "[Generic clocks](#)" on page 61.

The oscillators are disabled by default after reset. When the oscillators are disabled, the XIN and XOUT pins can be used as general purpose I/Os. When the oscillators are configured to use an external clock, the clock must be applied to the XIN pin while the XOUT pin can be used as a general purpose I/O.

The oscillators can be enabled by writing to the OSCnEN bits in MCCTRL. Operation mode (external clock or crystal) is chosen by writing to the MODE field in OSCCTRLn. Oscillators are automatically switched off in certain sleep modes to reduce power consumption, as described in [Section 13.5.7](#) on page 60.

After a hard reset, or when waking up from a sleep mode that disabled the oscillators, the oscillators may need a certain amount of time to stabilize on the correct frequency. This start-up time can be set in the OSCCTRLn register.

The PM masks the oscillator outputs during the start-up time, to ensure that no unstable clocks propagate to the digital logic. The OSCnRDY bits in POSCSR are automatically set and cleared according to the status of the oscillators. A zero to one transition on these bits can also be configured to generate an interrupt, as described in ["Interrupt Enable/Disable/Mask/Status/Clear" on page 76](#).

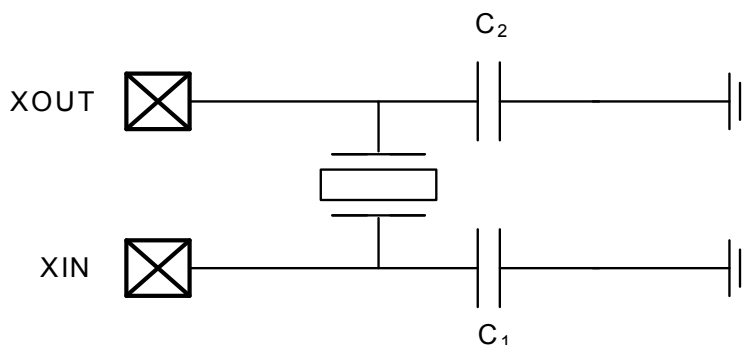

**Figure 13-2.** Oscillator connections

### 13.5.3 32 KHz oscillator operation

The 32 KHz oscillator operates as described for Oscillator 0 and 1 above. The 32 KHz oscillator is used as source clock for the Real-Time Counter.

The oscillator is disabled by default, but can be enabled by writing OSC32EN in OSCCTRL32. The oscillator is an ultra-low power design and remains enabled in all sleep modes except Static mode.

While the 32 KHz oscillator is disabled, the XIN32 and XOUT32 pins are available as general purpose I/Os. When the oscillator is configured to work with an external clock (MODE field in OSCCTRL32 register), the external clock must be connected to XIN32 while the XOUT32 pin can be used as a general purpose I/O.

The startup time of the 32 KHz oscillator can be set in the OSCCTRL32, after which OSC32RDY in POSCSR is set. An interrupt can be generated on a zero to one transition of OSC32RDY.

As a crystal oscillator usually requires a very long startup time (up to 1 second), the 32 KHz oscillator will keep running across resets, except Power-On-Reset.

### 13.5.4 PLL operation

The device contains two PLLs, PLL0 and PLL1. These are disabled by default, but can be enabled to provide high frequency source clocks for synchronous or generic clocks. The PLLs can take either Oscillator 0 or 1 as reference clock. The PLL output is divided by a multiplication factor, and the PLL compares the resulting clock to the reference clock. The PLL will adjust its output frequency until the two compared clocks are equal, thus locking the output frequency to a multiple of the reference clock frequency.

The Voltage Controlled Oscillator inside the PLL can generate frequencies from 80 to 240 MHz. To make the PLL output frequencies under 80 MHz the OTP[1] bitfield could be set. This will



divide the output of the PLL by two and bring the clock in range of the max frequency of the CPU.

When the PLL is switched on, or when changing the clock source or multiplication factor for the PLL, the PLL is unlocked and the output frequency is undefined. The PLL clock for the digital logic is automatically masked when the PLL is unlocked, to prevent connected digital logic from receiving a too high frequency and thus become unstable.

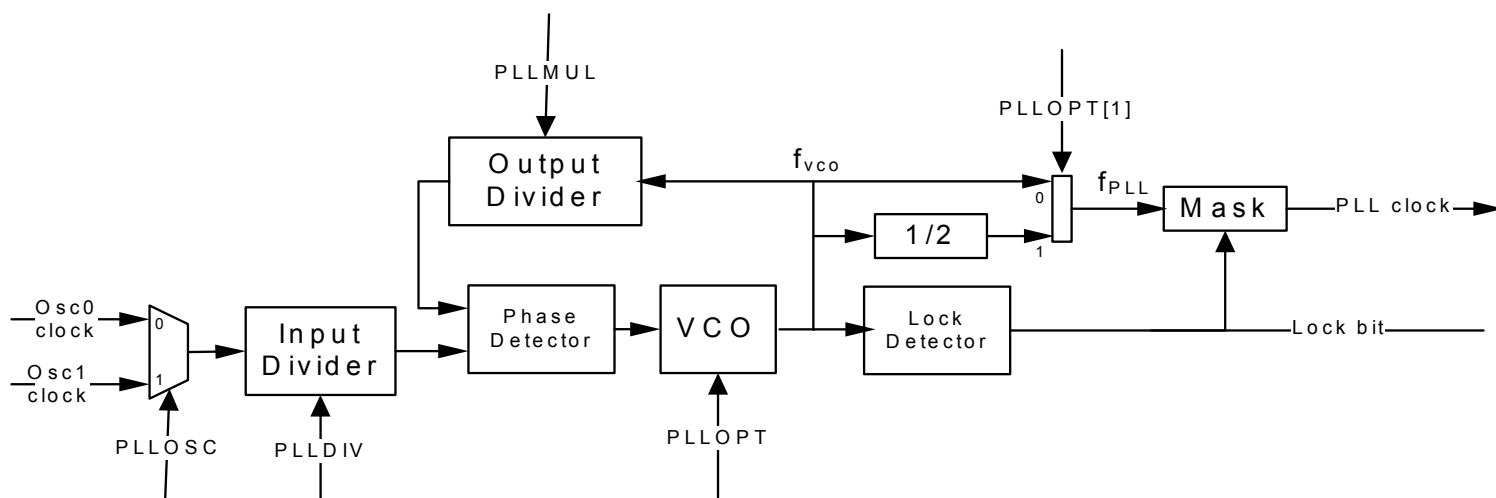

**Figure 13-3.** PLL with control logic and filters

### 13.5.4.1 Enabling the PLL

PLL<sub>n</sub> is enabled by writing the PLEN bit in the PLL<sub>n</sub> register. PLLOSC selects Oscillator 0 or 1 as clock source. The PLLMUL and PLLDIV bitfields must be written with the multiplication and division factors, respectively, creating the voltage controlled oscillator frequency  $f_{VCO}$  and the PLL frequency  $f_{PLL}$  :

$$f_{VCO} = (PLLMUL+1)/(PLLDIV) \cdot f_{OSC} \text{ if } PLLDIV > 0.$$

$$f_{VCO} = 2 \cdot (PLLMUL+1) \cdot f_{OSC} \text{ if } PLLDIV = 0.$$

If PLLOPT[1] field is set to 0:

$$f_{PLL} = f_{VCO}.$$

If PLLOPT[1] field is set to 1:

$$f_{PLL} = f_{VCO} / 2.$$

The PLL<sub>n</sub>:PLLOPT field should be set to proper values according to the PLL operating frequency. The PLLOPT field can also be set to divide the output frequency of the PLLs by 2.

The lock signal for each PLL is available as a LOCK<sub>n</sub> flag in POSCSR. An interrupt can be generated on a 0 to 1 transition of these bits.

## 13.5.5 Synchronous clocks

The slow clock (default), Oscillator 0, or PLL0 provide the source for the main clock, which is the common root for the synchronous clocks for the CPU/HSB, PBA, and PBB modules. The main clock is divided by an 8-bit prescaler, and each of these four synchronous clocks can run from any tapping of this prescaler, or the undivided main clock, as long as  $f_{CPU} \leq f_{PBA,B}$ . The synchronous clock source can be changed on-the fly, responding to varying load in the application. The clock domains can be shut down in sleep mode, as described in "Sleep modes" on page 60. Additionally, the clocks for each module in the four domains can be individually masked, to avoid power consumption in inactive modules.

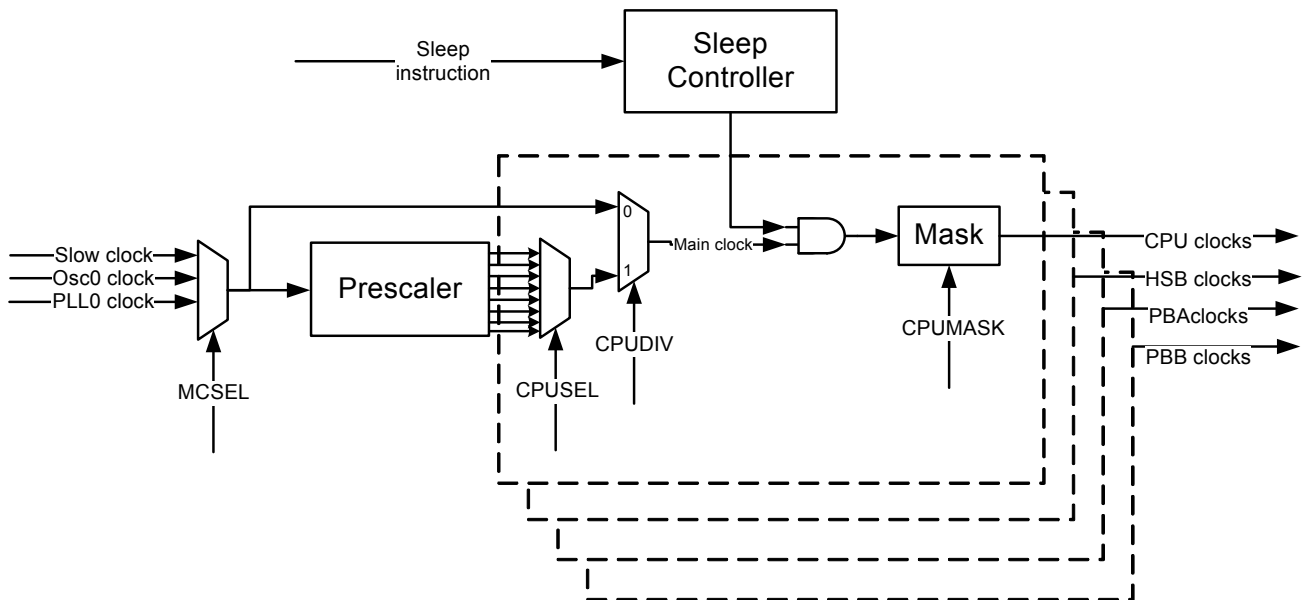

**Figure 13-4.** Synchronous clock generation

### 13.5.5.1 Selecting PLL or oscillator for the main clock

The common main clock can be connected to the slow clock, Oscillator 0, or PLL0. By default, the main clock will be connected to the slow clock. The user can connect the main clock to Oscillator 0 or PLL0 by writing the MCSEL bitfield in the Main Clock Control Register (MCCTRL). This must only be done after that unit has been enabled, otherwise a deadlock will occur. Care should also be taken that the new frequency of the synchronous clocks does not exceed the maximum frequency for each clock domain.

### 13.5.5.2 Selecting synchronous clock division ratio

The main clock feeds an 8-bit prescaler, which can be used to generate the synchronous clocks. By default, the synchronous clocks run on the undivided main clock. The user can select a pres-

caler division for the CPU clock by writing CKSEL:CPUDIV to 1 and CPUSEL to the prescaling value, resulting in a CPU clock frequency:

$$f_{\text{CPU}} = f_{\text{main}} / 2^{(\text{CPUSEL}+1)}$$

Similarly, the clock for the PBA, and PBB can be divided by writing their respective bitfields. To ensure correct operation, frequencies must be selected so that  $f_{\text{CPU}} \leq f_{\text{PBA,B}}$ . Also, frequencies must never exceed the specified maximum frequency for each clock domain.

CKSEL can be written without halting or disabling peripheral modules. Writing CKSEL allows a new clock setting to be written to all synchronous clocks at the same time. It is possible to keep one or more clocks unchanged by writing the same value a before to the xxxDIV and xxxSEL bit-fields. This way, it is possible to e.g. scale CPU and HSB speed according to the required performance, while keeping the PBA and PBB frequency constant.

### 13.5.5.3 Clock Ready flag

There is a slight delay from CKSEL is written and the new clock setting becomes effective. During this interval, the Clock Ready (CKRDY) flag in ISR will read as 0. If IER:CKRDY is written to 1, the Power Manager interrupt can be triggered when the new clock setting is effective. CKSEL must not be re-written while CKRDY is 0, or the system may become unstable or hang.

## 13.5.6 Peripheral clock masking

By default, the clock for all modules are enabled, regardless of which modules are actually being used. It is possible to disable the clock for a module in the CPU, HSB, PBA, or PBB clock domain by writing the corresponding bit in the Clock Mask register (CPU/HSB/PBA/PBB) to 0. When a module is not clocked, it will cease operation, and its registers cannot be read or written. The module can be re-enabled later by writing the corresponding mask bit to 1.

A module may be connected to several clock domains, in which case it will have several mask bits.

[Table 13-5](#) contains a list of implemented maskable clocks.

### 13.5.6.1 Cautionary note

Note that clocks should only be switched off if it is certain that the module will not be used. Switching off the clock for the internal RAM will cause a problem if the stack is mapped there. Switching off the clock to the Power Manager (PM), which contains the mask registers, or the corresponding PBx bridge, will make it impossible to write the mask registers again. In this case, they can only be re-enabled by a system reset.

### 13.5.6.2 Mask Ready flag

Due to synchronization in the clock generator, there is a slight delay from a mask register is written until the new mask setting goes into effect. When clearing mask bits, this delay can usually be ignored. However, when setting mask bits, the registers in the corresponding module must not be written until the clock has actually be re-enabled. The status flag MSKRDY in ISR provides the required mask status information. When writing either mask register with any value, this bit is cleared. The bit is set when the clocks have been enabled and disabled according to the new mask setting. Optionally, the Power Manager interrupt can be enabled by writing the MSKRDY bit in IER.

## 13.5.7 Sleep modes

In normal operation, all clock domains are active, allowing software execution and peripheral operation. When the CPU is idle, it is possible to switch off the CPU clock and optionally other clock domains to save power. This is activated by the sleep instruction, which takes the sleep mode index number as argument.

### 13.5.7.1 Entering and exiting sleep modes

The sleep instruction will halt the CPU and all modules belonging to the stopped clock domains. The modules will be halted regardless of the bit settings of the mask registers.

Oscillators and PLLs can also be switched off to save power. Some of these modules have a relatively long start-up time, and are only switched off when very low power consumption is required.

The CPU and affected modules are restarted when the sleep mode is exited. This occurs when an interrupt triggers. Note that even if an interrupt is enabled in sleep mode, it may not trigger if the source module is not clocked.

### 13.5.7.2 Supported sleep modes

The following sleep modes are supported. These are detailed in [Table 13-1](#).

- Idle: The CPU is stopped, the rest of the chip is operating. Wake-up sources are any interrupt.
- Frozen: The CPU and HSB modules are stopped, peripherals are operating. Wake-up sources are any interrupt from PB modules.
- Standby: All synchronous clocks are stopped, but oscillators and PLLs are running, allowing quick wake-up to normal mode. Wake-up sources are RTC or external interrupt (EIC).
- Stop: As Standby, but Oscillator 0 and 1, and the PLLs are stopped. 32 KHz (if enabled) and RC oscillators and RTC/WDT still operate. Wake-up sources are RTC, external interrupt (EIC), or external reset pin.
- DeepStop: All synchronous clocks, Oscillator 0 and 1 and PLL 0 and 1 are stopped. 32 KHz oscillator can run if enabled. RC oscillator still operates. Bandgap voltage reference and BOD is turned off. Wake-up sources are RTC, external interrupt (EIC) or external reset pin.
- Static: All oscillators, including 32 KHz and RC oscillator are stopped. Bandgap voltage reference BOD detector is turned off. Wake-up sources are external interrupt (EIC) in asynchronous mode only or external reset pin.

**Table 13-1.** Sleep modes

Index	Sleep Mode	CPU	HSB	PBA,B GCLK	Osc0,1 PLL0,1	Osc32	RCOsc	BOD & Bandgap	Voltage Regulator
0	<b>Idle</b>	Stop	Run	Run	Run	Run	Run	On	Full power
1	<b>Frozen</b>	Stop	Stop	Run	Run	Run	Run	On	Full power
2	<b>Standby</b>	Stop	Stop	Stop	Run	Run	Run	On	Full power
3	<b>Stop</b>	Stop	Stop	Stop	Stop	Run	Run	On	Low power
4	<b>DeepStop</b>	Stop	Stop	Stop	Stop	Run	Run	Off	Low power
5	<b>Static</b>	Stop	Stop	Stop	Stop	Stop	Stop	Off	Low power

The power level of the internal voltage regulator is also adjusted according to the sleep mode to reduce the internal regulator power consumption.

#### 13.5.7.3 *Precautions when entering sleep mode*

Modules communicating with external circuits should normally be disabled before entering a sleep mode that will stop the module operation. This prevents erratic behavior when entering or exiting sleep mode. Please refer to the relevant module documentation for recommended actions.

Communication between the synchronous clock domains is disturbed when entering and exiting sleep modes. This means that bus transactions are not allowed between clock domains affected by the sleep mode. The system may hang if the bus clocks are stopped in the middle of a bus transaction.

The CPU is automatically stopped in a safe state to ensure that all CPU bus operations are complete when the sleep mode goes into effect. Thus, when entering Idle mode, no further action is necessary.

When entering a sleep mode (except Idle mode), all HSB masters must be stopped before entering the sleep mode. Also, if there is a chance that any PB write operations are incomplete, the CPU should perform a read operation from any register on the PB bus before executing the sleep instruction. This will stall the CPU while waiting for any pending PB operations to complete.

#### 13.5.7.4 *Wake up*

The USB can be used to wake up the part from sleep modes through register PM\_AWEN of the Power Manager.

### 13.5.8 **Generic clocks**

Timers, communication modules, and other modules connected to external circuitry may require specific clock frequencies to operate correctly. The Power Manager contains an implementation defined number of generic clocks that can provide a wide range of accurate clock frequencies.

Each generic clock module runs from either Oscillator 0 or 1, or PLL0 or 1. The selected source can optionally be divided by any even integer up to 512. Each clock can be independently enabled and disabled, and is also automatically disabled along with peripheral clocks by the Sleep Controller.

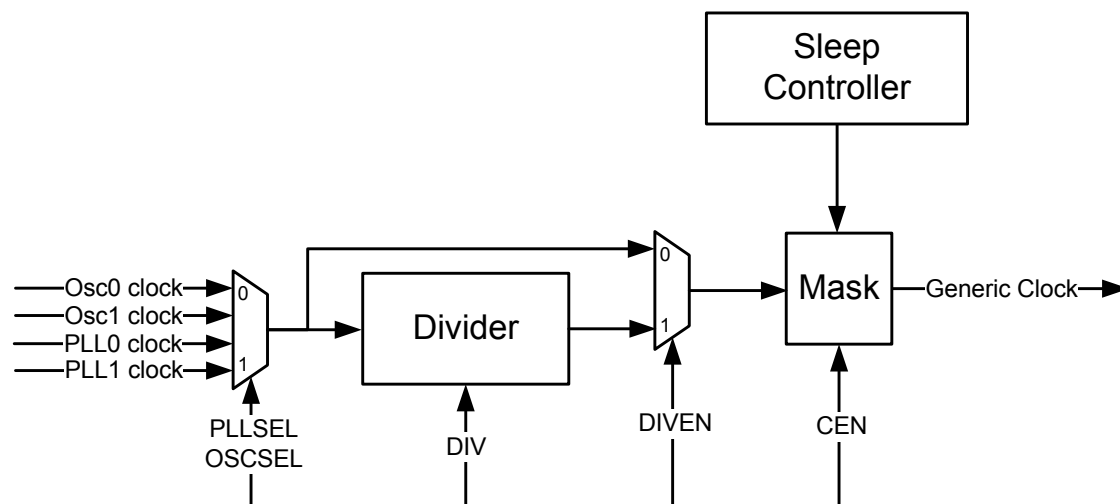

**Figure 13-5.** Generic clock generation

#### 13.5.8.1 Enabling a generic clock

A generic clock is enabled by writing the CEN bit in GCCTRL to 1. Each generic clock can use either Oscillator 0 or 1 or PLL0 or 1 as source, as selected by the PLLSEL and OSCSEL bits. The source clock can optionally be divided by writing DIVEN to 1 and the division factor to DIV, resulting in the output frequency:

$$f_{\text{GCLK}} = f_{\text{SRC}} / (2 * (\text{DIV} + 1))$$

#### 13.5.8.2 Disabling a generic clock

The generic clock can be disabled by writing CEN to 0 or entering a sleep mode that disables the PB clocks. In either case, the generic clock will be switched off on the first falling edge after the disabling event, to ensure that no glitches occur. If CEN is written to 0, the bit will still read as 1 until the next falling edge occurs, and the clock is actually switched off. When writing CEN to 0, the other bits in GCCTRL should not be changed until CEN reads as 0, to avoid glitches on the generic clock.

When the clock is disabled, both the prescaler and output are reset.

#### 13.5.8.3 Changing clock frequency

When changing generic clock frequency by writing GCCTRL, the clock should be switched off by the procedure above, before being re-enabled with the new clock source or division setting. This prevents glitches during the transition.

#### 13.5.8.4 Generic clock implementation

In AT32UC3A, there are 6 generic clocks. These are allocated to different functions as shown in [Table 13-2](#).

**Table 13-2.** Generic clock allocation

Clock number	Function
0	GCLK0 pin
1	GCLK1 pin
2	GCLK2 pin
3	GCLK3 pin
4	USBB
5	ABDAC

#### 13.5.9 Divided PB clocks

The clock generator in the Power Manager provides divided PBA and PBB clocks for use by peripherals that require a prescaled PBx clock. This is described in the documentation for the relevant modules.

The divided clocks are not directly maskable, but are stopped in sleep modes where the PBx clocks are stopped.

#### 13.5.10 Debug operation

During a debug session, the user may need to halt the system to inspect memory and CPU registers. The clocks normally keep running during this debug operation, but some peripherals may require the clocks to be stopped, e.g. to prevent timer overflow, which would cause the program to fail. For this reason, peripherals on the PBA and PBB buses may use “debug qualified” PBx clocks. This is described in the documentation for the relevant modules. The divided PBx clocks are always debug qualified clocks.

Debug qualified PB clocks are stopped during debug operation. The debug system can optionally keep these clocks running during the debug operation. This is described in the documentation for the On-Chip Debug system.

#### 13.5.11 Reset Controller

The Reset Controller collects the various reset sources in the system and generates hard and soft resets for the digital logic.

The device contains a Power-On Detector, which keeps the system reset until power is stable. This eliminates the need for external reset circuitry to guarantee stable operation when powering up the device.

It is also possible to reset the device by asserting the RESET\_N pin. This pin has an internal pull-up, and does not need to be driven externally when negated. Table 13-4 lists these and other reset sources supported by the Reset Controller.

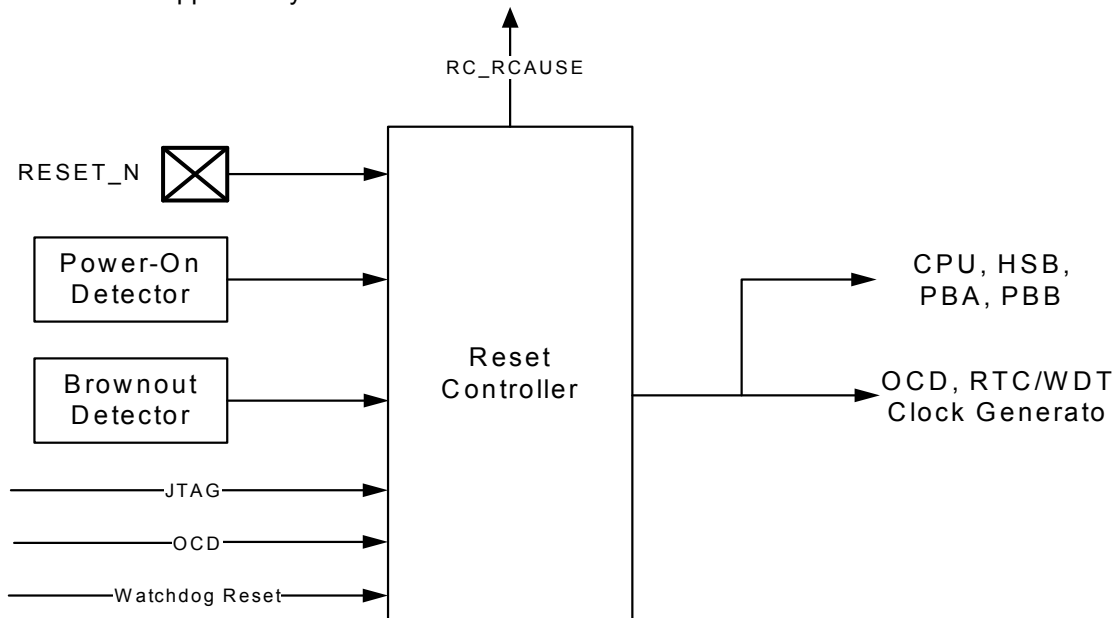

**Figure 13-6.** Reset Controller block diagram

In addition to the listed reset types, the JTAG can keep parts of the device statically reset through the JTAG Reset Register. See JTAG documentation for details.

**Table 13-3.** Reset description

Reset source	Description
Power-on Reset	Supply voltage below the power-on reset detector threshold voltage
External Reset	RESET_N pin asserted
Brownout Reset	Supply voltage below the brownout reset detector threshold voltage
CPU Error	Caused by an illegal CPU access to external memory while in Supervisor mode
Watchdog Timer	See watchdog timer documentation.
OCD	See On-Chip Debug documentation

When a Reset occurs, some parts of the chip are not necessarily reset, depending on the reset source. Only the Power On Reset (POR) will force a reset of the whole chip.



Table 13-4 lists parts of the device that are reset, depending on the reset source.

**Table 13-4.** Effect of the different reset events

	Power-On Reset	External Reset	Watchdog Reset	BOD Reset	CPU Error Reset	OCD Reset
CPU/HSB/PBA/PBB (excluding Power Manager)	Y	Y	Y	Y	Y	Y
32 KHz oscillator	Y	N	N	N	N	N
RTC control register	Y	N	N	N	N	N
GPLP registers	Y	N	N	N	N	N
Watchdog control register	Y	Y	N	Y	Y	Y
Voltage Calibration register	Y	N	N	N	N	N
RC Oscillator Calibration register	Y	N	N	N	N	N
BOD control register	Y	Y	N	N	N	N
Bandgap control register	Y	Y	N	N	N	N
Clock control registers	Y	Y	Y	Y	Y	Y
Osc0/Osc1 and control registers	Y	Y	Y	Y	Y	Y
PLL0/PLL1 and control registers	Y	Y	Y	Y	Y	Y
OCD system and OCD registers	Y	Y	N	Y	Y	N

The cause of the last reset can be read from the RCAUSE register. This register contains one bit for each reset source, and can be read during the boot sequence of an application to determine the proper action to be taken.

### 13.5.11.1 Power-On Detector

The Power-On Detector monitors the VDDCORE supply pin and generates a reset when the device is powered on. The reset is active until the supply voltage from the linear regulator is above the power-on threshold level. The reset will be re-activated if the voltage drops below the power-on threshold level. See Electrical Characteristics for parametric details.

### 13.5.11.2 Brown-Out Detector

The Brown-Out Detector (BOD) monitors the VDDCORE supply pin and compares the supply voltage to the brown-out detection level, as set in BOD:LEVEL. The BOD is disabled by default, but can be enabled either by software or by flash fuses. The Brown-Out Detector can either generate an interrupt or a reset when the supply voltage is below the brown-out detection level. In any case, the BOD output is available in bit POSCR:BODET bit.

Note that any change to the BOD:LEVEL field of the BOD register should be done with the BOD deactivated to avoid spurious reset or interrupt.

See Electrical Characteristics for parametric details.

### 13.5.11.3 External Reset

The external reset detector monitors the state of the RESET\_N pin. By default, a low level on this pin will generate a reset.

### 13.5.12 Calibration registers

The Power Manager controls the calibration of the RC oscillator, voltage regulator, bandgap voltage reference through several calibrations registers.

Those calibration registers are loaded after a Power On Reset with default values stored in factory-programmed flash fuses.

Although it is not recommended to override default factory settings, it is still possible to override these default values by writing to those registers. To prevent unexpected writes due to software bugs, write access to these registers is protected by a “key”. First, a write to the register must be made with the field “KEY” equal to 0x55 then a second write must be issued with the “KEY” field equal to 0xAA

## 13.6 User Interface

Offset	Register	Name	Access	Reset State
0x0000	Main Clock Control	MCCTRL	Read/Write	0x00000000
0x0004	Clock Select	CKSEL	Read/Write	0x00000000
0x0008	CPU Mask	CPUMASK	Read/Write	0x00000003
0x000C	HSB Mask	HSBMASK	Read/Write	0x0000007F
0x0010	PBA Mask	PBAMASK	Read/Write	0x0000FFFF
0x0014	PBB Mask	PBBMASK	Read/Write	0x0000003F
0x0018 - 0x001C	Reserved			
0x0020	PLL0 Control	PLL0	Read/Write	0x00000000
0x0024	PLL1 Control	PLL1	Read/Write	0x00000000
0x0028	Oscillator 0 Control Register	OSCCTRL0	Read/Write	0x00000000
0x002C	Oscillator 1 Control Register	OSCCTRL1	Read/Write	0x00000000
0x0030	Oscillator 32 Control Register	OSCCTRL32	Read/Write	0x00000000
0x0034	Reserved			
0x0038	Reserved			
0x003C	Reserved			
0x0040	PM Interrupt Enable Register	IER	Write Only	0x00000000
0x0044	PM Interrupt Disable Register	IDR	Write Only	0x00000000
0x0048	PM Interrupt Mask Register	IMR	Read Only	0x00000000
0x004C	PM Interrupt Status Register	ISR	Read Only	0x00000000
0x0050	PM Interrupt Clear Register	ICR	Write Only	0x00000000
0x0054	Power and Oscillators Status Register	POSCSR	Read/Write	0x00000000
0x0058 - 0x005C	Reserved			

0x0060	Generic Clock Control	GCCTRL	Read/Write	0x00000000
0x0064 - 0x00BC	Reserved			
0x00C0	RC Oscillator Calibration Register	RCCR	Read/Write	Factory settings
0x00C4	Bandgap Calibration Register	BGCR	Read/Write	Factory settings
0x00C8	Linear Regulator Calibration Register	VREGCR	Read/Write	Factory settings
0x00CC	Reserved			
0x00D0	BOD Level Register	BOD	Read/Write	BOD fuses in Flash
0x00D4 - 0x013C	Reserved			
0x0140	Reset Cause Register	RCAUSE	Read Only	Latest Reset Source
0x0144 - 0x01FC	Reserved			
0x0200	General Purpose Low-Power register 0	GPLP0	Read/Write	0x00000000
0x0204	General Purpose Low-Power register 1	GPLP1	Read/Write	0x00000000

## 13.6.1 Main Clock Control

**Name:** MCCTRL

**Access Type:** Read/Write

31	30	29	28	27	26	25	24
-	-	-	-	-	-	-	-
23	22	21	20	19	18	17	16
-	-	-	-	-	-	-	-
15	14	13	12	11	10	9	8
-	-	-	-	-	-	-	-
7	6	5	4	3	2	1	0
-	-			OSC1EN	OSC0EN	MCSEL	

- **MCSEL: Main Clock Select**

- 0: The slow clock is the source for the main clock
- 1: Oscillator 0 is source for the main clock
- 2: PLL0 is source for the main clock
- 3: Reserved

- **OSC0EN: Oscillator 0 Enable**

- 0: Oscillator 0 is disabled
- 1: Oscillator 0 is enabled

- **OSC1EN: Oscillator 1 Enable**

- 0: Oscillator 1 is disabled
- 1: Oscillator 1 is enabled

## 13.6.2 Clock Select

**Name:** CKSEL

**Access Type:** Read/Write

31	30	29	28	27	26	25	24
PBBDIV	-	-	-	-	PBBSEL		
23	22	21	20	19	18	17	16
PBADIV	-	-	-	-	PBASEL		
15	14	13	12	11	10	9	8
HSBDIV	-	-	-	-	HSBSEL		
7	6	5	4	3	2	1	0
CPUDIV	-	-	-	-	CPUSEL		

- **PBBDIV, PBBSEL: PBB Division and Clock Select**

PBBDIV = 0: PBB clock equals main clock.

PBBDIV = 1: PBB clock equals main clock divided by  $2^{(PBBSEL+1)}$ .

- **PBADIV, PBASEL: PBA Division and Clock Select**

PBADIV = 0: PBA clock equals main clock.

PBADIV = 1: PBA clock equals main clock divided by  $2^{(PBASEL+1)}$ .

- **HSBDIV, HSBSEL: HSB Division and Clock Select**

For the AT32UC3A, HSBDIV always equals CPUDIV, and HSBSEL always equals CPUSEL, as the HSB clock is always equal to the CPU clock.

- **CPUDIV, CPUSEL: CPU Division and Clock Select**

CPUDIV = 0: CPU clock equals main clock.

CPUDIV = 1: CPU clock equals main clock divided by  $2^{(CPUSEL+1)}$ .

Note that if xxxDIV is written to 0, xxxSEL should also be written to 0 to ensure correct operation.

Also note that writing this register clears POSCSR:CKRDY. The register must not be re-written until CKRDY goes high.

## 13.6.3 Clock Mask

**Name:** CPU/HSB/PBA/PBBMASK

**Access Type:** Read/Write

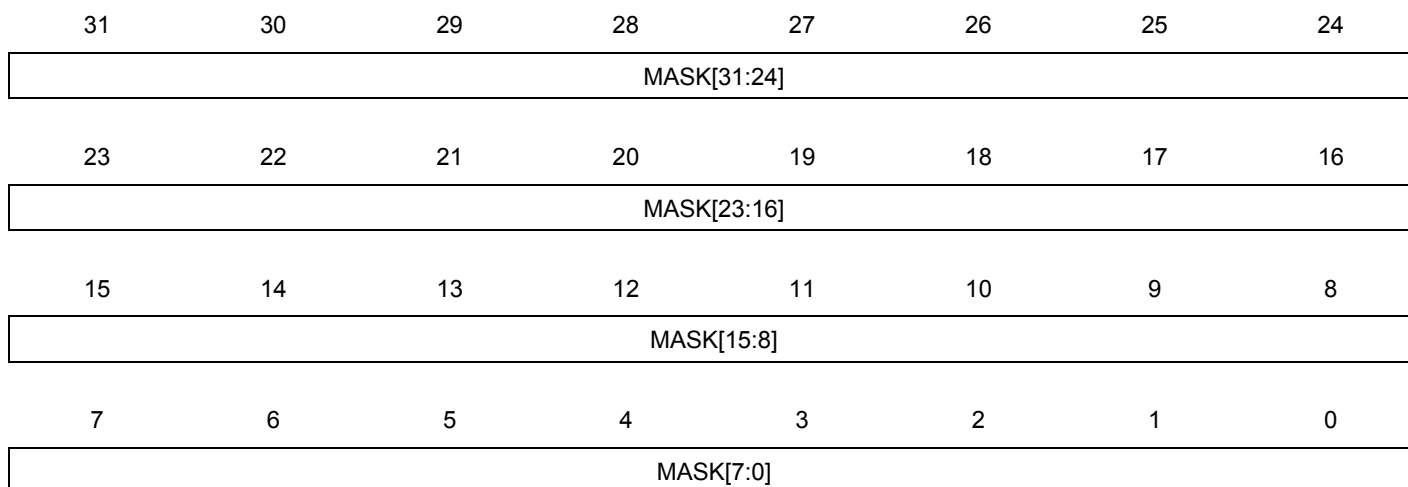

- **MASK: Clock Mask**

If bit n is cleared, the clock for module n is stopped. If bit n is set, the clock for module n is enabled according to the current power mode. The number of implemented bits in each mask register, as well as which module clock is controlled by each bit, is shown in [Table 13-5](#).

**Table 13-5.** Maskable module clocks in AT32UC3A.

Bit	CPUMASK	HSBMASK	PBAMASK	PBBMASK
0	-	FLASHC	INTC	HMATRIX
1	OCD	PBA bridge	GPIO	USBB
2	-	PBB bridge	PDCA	FLASHC
3	-	USBB	PM/RTC/EIC	MACB
4	-	MACB	ADC	SMC
5	-	PDCA	SPI0	SDRAMC
6	-	EBI	SPI1	-
7	-	-	TWI	-
8	-	-	USART0	-
9	-	-	USART1	-
10	-	-	USART2	-
11	-	-	USART3	-
12	-	-	PWM	-
13	-	-	SSC	-

**Table 13-5.** Maskable module clocks in AT32UC3A.

Bit	CPUMASK	HSBMASK	PBAMASK	PBBMASK
14	-	-	TC	-
15	-	-	ABDAC	-
16	SYSTIMER (COMPARE/COUNT REGISTERS CLK)	-	-	-
31: 17	-	-	-	-

## 13.6.4 PLL Control

**Name:** PLL0,1

**Access Type:** Read/Write

31	30	29	28	27	26	25	24
RESERVED			PLLCOUNT				
23	22	21	20	19	18	17	16
RESERVED				PLLMUL			
15	14	13	12	11	10	9	8
RESERVED				PLLDIV			
7	6	5	4	3	2	1	0
-	-	-	PLLOPT			PLLOSC	PLEN

- **RESERVED: Reserved bitfields**

Reserved for internal use. Always write to 0.

- **PLLCOUNT: PLL Count**

Specifies the number of slow clock cycles before ISR:LOCKn will be set after PLLn has been written, or after PLLn has been automatically re-enabled after exiting a sleep mode.

- **PLLMUL: PLL Multiply Factor**

- **PLLDIV: PLL Division Factor**

These bitfields determine the ratio of the PLL output frequency (voltage controlled oscillator frequency  $f_{VCO}$ ) to the source oscillator frequency:

$$f_{VCO} = (PLLMUL+1)/(PLLDIV) \cdot f_{OSC} \text{ if } PLLDIV > 0.$$

$$f_{VCO} = 2 \cdot (PLLMUL+1) \cdot f_{OSC} \text{ if } PLLDIV = 0.$$

If PLLOPT[1] field is set to 0:

$$f_{PLL} = f_{VCO}.$$

If PLLOPT[1] field is set to 1:

$$f_{PLL} = f_{VCO} / 2.$$

Note that the MUL field cannot be equal to 0 or 1, or the behavior of the PLL will be undefined.

- **PLLOPT: PLL Option**

Select the operating range for the PLL.

PLLOPT[0]: Select the VCO frequency range.

PLLOPT[1]: Enable the extra output divider.

PLLOPT[2]: Disable the Wide-Bandwidth mode (Wide-Bandwidth mode allows a faster startup time and out-of-lock time).



**Table 13-6.** PLLOPT Fields Description in AT32UC3A

	Description
PLLOPT[0]: VCO frequency	
0	$160\text{MHz} < f_{\text{vco}} < 240\text{MHz}$
1	$80\text{MHz} < f_{\text{vco}} < 180\text{MHz}$
PLLOPT[1]: Output divider	
0	$f_{\text{PLL}} = f_{\text{vco}}$
1	$f_{\text{PLL}} = f_{\text{vco}}/2$
PLLOPT[2]	
0	Wide Bandwidth Mode enabled
1	Wide Bandwidth Mode disabled

- **PLLOSC: PLL Oscillator Select**

0: Oscillator 0 is the source for the PLL.

1: Oscillator 1 is the source for the PLL.

- **PPLEN: PLL Enable**

0: PLL is disabled.

1: PLL is enabled.

## 13.6.5 PM Oscillator 0/1 Control

**Register name** OSCCTRL0,1

**Register access** Read/Write

31	30	29	28	27	26	25	24
-	-	-	-	-	-	-	-
23	22	21	20	19	18	17	16
-	-	-	-	-	-	-	-
15	14	13	12	11	10	9	8
-	-	-	-	-	STARTUP		
7	6	5	4	3	2	1	0
-	-	-	-	-	MODE		

- **MODE: Oscillator Mode**

Choose between crystal, or external clock

0: External clock connected on XIN, XOUT can be used as an I/O (no crystal)

1 to 3: reserved

4: Crystal is connected to XIN/XOUT - Oscillator is used with gain G0 ( XIN from 0.4 MHz to 0.9 MHz ).

5: Crystal is connected to XIN/XOUT - Oscillator is used with gain G1 ( XIN from 0.9 MHz to 3.0 MHz ).

6: Crystal is connected to XIN/XOUT - Oscillator is used with gain G2 ( XIN from 3.0 MHz to 8.0 MHz ).

7: Crystal is connected to XIN/XOUT - Oscillator is used with gain G3 ( XIN from 8.0 Mhz).

- **STARTUP: Oscillator Startup Time**

Select startup time for the oscillator.

**Table 13-7.** Startup time for oscillators 0 and 1

STARTUP	Number of RC oscillator clock cycle	Approximative Equivalent time (RCOsc = 115 kHz)
0	0	0
1	64	560 us
2	128	1.1 ms
3	2048	18 ms
4	4096	36 ms
5	8192	71 ms
6	16384	142 ms
7	<i>Reserved</i>	<i>Reserved</i>

## 13.6.6 PM 32 KHz Oscillator Control Register

**Register name** OSCCTRL32

**Register access** Read/Write

31	30	29	28	27	26	25	24
-	-	-	-	-	-	-	-
23	22	21	20	19	18	17	16
-	-	-	-	-	STARTUP		
15	14	13	12	11	10	9	8
-	-	-	-	-	MODE		
7	6	5	4	3	2	1	0
-	-	-	-	-	-	-	OSC32EN

Note: This register is only reset by Power-On Reset

- **OSC32EN: Enable the 32 KHz oscillator**

0: 32 KHz Oscillator is disabled

1: 32 KHz Oscillator is enabled

- **MODE: Oscillator Mode**

Choose between crystal, or external clock

0: External clock connected on XIN32, XOUT32 can be used as a I/O (no crystal)

1: Crystal is connected to XIN32/XOUT32

2 to 7: reserved

- **STARTUP: Oscillator Startup Time**

Select startup time for 32 KHz oscillator

**Table 13-8.** Startup time for 32 KHz oscillator

STARTUP	Number of RC oscillator clock cycle	Approximative Equivalent time (RCOsc = 115 kHz)
0	0	0
1	128	1.1 ms
2	8192	72.3 ms
3	16384	143 ms
4	65536	570 ms
5	131072	1.1 s
6	262144	2.3 s
7	524288	4.6 s

## 13.6.7 Interrupt Enable/Disable/Mask/Status/Clear

**Name:** IER/IDR/IMR/ISR/ICR

**Access Type:** IER/IDR/ICR: Write-only

IMR/ISR: Read-only

31	30	29	28	27	26	25	24
-	-	-	-	-	-	-	-
23	22	21	20	19	18	17	16
-	-	-	-	-	-	-	BODDET
15	14	13	12	11	10	9	8
-	-	-	-	-	-	OSC32RDY	OSC1RDY
7	6	5	4	3	2	1	0
OSCORDY	MSKRDY	CKRDY	-	-	-	LOCK1	LOCK0

- **BODDET: Brown out detection**

Set to 1 when 0 to 1 transition on POSCSR:BODDET bit is detected: BOD has detected that power supply is going below BOD reference value.

- **OSC32RDY: 32 KHz oscillator Ready**

Set to 1 when 0 to 1 transition on the POSCSR:OSC32RDY bit is detected: The 32 KHz oscillator is stable and ready to be used as clock source.

- **OSC1RDY: Oscillator 1 Ready**

Set to 1 when 0 to 1 transition on the POSCSR:OSC1RDY bit is detected: Oscillator 1 is stable and ready to be used as clock source.

- **OSC0RDY: Oscillator 0 Ready**

Set to 1 when 0 to 1 transition on the POSCSR:OSC1RDY bit is detected: Oscillator 1 is stable and ready to be used as clock source.

- **MSKRDY: Mask Ready**

Set to 1 when 0 to 1 transition on the POSCSR:MSKRDY bit is detected: Clocks are now masked according to the (CPU/HSB/PBA/PBB)\_MASK registers.

- **CKRDY: Clock Ready**

0: The CKSEL register has been written, and the new clock setting is not yet effective.

1: The synchronous clocks have frequencies as indicated in the CKSEL register.

Note: Writing ICR:CKRDY to 1 has no effect.

- **LOCK1: PLL1 locked**

Set to 1 when 0 to 1 transition on the POSCSR:LOCK1 bit is detected: PLL 1 is locked and ready to be selected as clock source.

- **LOCK0: PLL0 locked**

Set to 1 when 0 to 1 transition on the POSCSR:LOCK0 bit is detected: PLL 0 is locked and ready to be selected as clock source.

The effect of writing or reading the bits listed above depends on which register is being accessed:

- **IER (Write-only)**
  - 0: No effect
  - 1: Enable Interrupt
- **IDR (Write-only)**
  - 0: No effect
  - 1: Disable Interrupt
- **IMR (Read-only)**
  - 0: Interrupt is disabled
  - 1: Interrupt is enabled
- **ISR (Read-only)**
  - 0: An interrupt event has not occurred or has been previously cleared
  - 1: An interrupt event has not occurred
- **ICR (Write-only)**
  - 0: No effect
  - 1: Clear corresponding event

## 13.6.8 Power and Oscillators Status

**Name:** POSCSR

**Access Type:** Read-only

31	30	29	28	27	26	25	24
-	-	-	-	-	-	-	-
23	22	21	20	19	18	17	16
-	-	-	-	-	-	-	BODDET
15	14	13	12	11	10	9	8
-	-	-	-	-	-	OSC32RDY	OSC1RDY
7	6	5	4	3	2	1	0
OSC0RDY	MSKRDY	CKRDY	-	-	-	LOCK1	LOCK0

- **BODDET: Brown out detection**
  - 0: No BOD event
  - 1: BOD has detected that power supply is going below BOD reference value.
- **OSC32RDY: 32 KHz oscillator Ready**
  - 0: The 32 KHz oscillator is not enabled or not ready.
  - 1: The 32 KHz oscillator is stable and ready to be used as clock source.
- **OSC1RDY: OSC1 ready**
  - 0: Oscillator 1 not enabled or not ready.
  - 1: Oscillator 1 is stable and ready to be used as clock source.
- **OSC0RDY: OSC0 ready**
  - 0: Oscillator 0 not enabled or not ready.
  - 1: Oscillator 0 is stable and ready to be used as clock source.
- **MSKRDY: Mask ready**
  - 0: Mask register has been changed, masking in progress.
  - 1: Clock are masked according to xxx\_MASK
- **CKRDY:**
  - 0: The CKSEL register has been written, and the new clock setting is not yet effective.
  - 1: The synchronous clocks have frequencies as indicated in the CKSEL register.
- **LOCK1: PLL 1 locked**
  - 0: PLL 1 is unlocked
  - 1: PLL 1 is locked, and ready to be selected as clock source.
- **LOCK0: PLL 0 locked**
  - 0: PLL 0 is unlocked
  - 1: PLL 0 is locked, and ready to be selected as clock source.

## 13.6.9 Generic Clock Control

**Name:** GCCTRL  
**Access Type:** Read/Write

31	30	29	28	27	26	25	24
-	-	-	-	-	-	-	-
23	22	21	20	19	18	17	16
-	-	-	-	-	-	-	-
15	14	13	12	11	10	9	8
DIV[7:0]							
7	6	5	4	3	2	1	0
-	-	-	DIVEN	-	CEN	PLLSEL	OSCSEL

There is one GCCTRL register per generic clock in the design.

- **DIV: Division Factor**
- **DIVEN: Divide Enable**
  - 0: The generic clock equals the undivided source clock.
  - 1: The generic clock equals the source clock divided by  $2^{(DIV+1)}$ .
- **CEN: Clock Enable**
  - 0: Clock is stopped.
  - 1: Clock is running.
- **PLLSEL: PLL Select**
  - 0: Oscillator is source for the generic clock.
  - 1: PLL is source for the generic clock.
- **OSCSEL: Oscillator Select**
  - 0: Oscillator (or PLL) 0 is source for the generic clock.
  - 1: Oscillator (or PLL) 1 is source for the generic clock.

## 13.6.10 Reset Cause

**Name:** RCAUSE

**Access Type:** Read-only

31	30	29	28	27	26	25	24
-	-	-	-	-	-	-	-
23	22	21	20	19	18	17	16
-	-	-	-	-	-	-	-
15	14	13	12	11	10	9	8
-	-	-	-	-	-	JTAGHARD	OCDRST
7	6	5	4	3	2	1	0
CPUERR	-	-	JTAG	WDT	EXT	BOD	POR

- **POR Power-on Reset**

The CPU was reset due to the supply voltage being lower than the power-on threshold level.

- **BOD: Brown-out Reset**

The CPU was reset due to the supply voltage being lower than the brown-out threshold level.

- **EXT: External Reset Pin**

The CPU was reset due to the RESET pin being asserted.

- **WDT: Watchdog Reset**

The CPU was reset because of a watchdog timeout.

- **JTAG: JTAG reset**

The CPU was reset by setting the bit RC\_CPU in the JTAG reset register.

- **CPUERR: CPU Error**

The CPU was reset because it had detected an illegal access.

- **OCDRST: OCD Reset**

The CPU was reset because the RES strobe in the OCD Development Control register has been written to one.

- **JTAGHARD: JTAG Hard Reset**

The chip was reset by setting the bit RC\_OCD in the JTAG reset register or by using the JTAG HALT instruction.



## 13.6.11 BOD Control

BOD Level register

**Register name** BOD  
**Register access** Read/Write

31	30	29	28	27	26	25	24
KEY							
23	22	21	20	19	18	17	16
-	-	-	-	-	-	-	FCD
15	14	13	12	11	10	9	8
-	-	-	-	-	-	CTRL	
7	6	5	4	3	2	1	0
-	HYST	LEVEL					

- **KEY: Register Write protection**

This field must be written twice, first with key value 0x55, then 0xAA, for a write operation to have an effect.

- **FCD: BOD Fuse calibration done**

Set to 1 when CTRL, HYST and LEVEL fields has been updated by the Flash fuses after power-on reset or Flash fuses update

If one, the CTRL, HYST and LEVEL values will not be updated again by Flash fuses

Can be cleared to allow subsequent overwriting of the value by Flash fuses

- **CTRL: BOD Control**

0: BOD is off

1: BOD is enabled and can reset the chip

2: BOD is enabled and but cannot reset the chip. Only interrupt will be sent to interrupt controller, if enabled in the IMR register.

3: BOD is off

- **HYST: BOD Hysteresis**

0: No hysteresis

1: Hysteresis On

- **LEVEL: BOD Level**

This field sets the triggering threshold of the BOD. See Electrical Characteristics for actual voltage levels.

Note that any change to the LEVEL field of the BOD register should be done with the BOD deactivated to avoid spurious reset or interrupt.

## 13.6.12 RC Oscillator Calibration

**Register name** RCCR  
**Register access** Read/Write

31	30	29	28	27	26	25	24
KEY							
23	22	21	20	19	18	17	16
-	-	-	-	-	-	-	FCD
15	14	13	12	11	10	9	8
-	-	-	-	-	-	CALIB	
7	6	5	4	3	2	1	0
CALIB							

- **CALIB: Calibration Value**  
 Calibration Value for the RC oscillator.
- **FCD: Flash Calibration Done**  
 Set to 1 when CTRL, HYST, and LEVEL fields have been updated by the Flash fuses after power-on reset, or after Flash fuses are reprogrammed. The CTRL, HYST and LEVEL values will not be updated again by the Flash fuses until a new power-on reset or the FCD field is written to zero.
- **KEY: Register Write protection**  
 This field must be written twice, first with key value 0x55, then 0xAA, for a write operation to have an effect.

## 13.6.13 Bandgap Calibration

**Register name** BGCR  
**Register access** Read/Write

31	30	29	28	27	26	25	24
KEY							
23	22	21	20	19	18	17	16
-	-	-	-	-	-	-	FCD
15	14	13	12	11	10	9	8
-	-	-	-	-	-	-	-
7	6	5	4	3	2	1	0
-	-	-	-	-	CALIB		

- **KEY: Register Write protection**

This field must be written twice, first with key value 0x55, then 0xAA, for a write operation to have an effect.

- **CALIB: Calibration value**

Calibration value for Bandgap. See Electrical Characteristics for voltage values.

- **FCD: Flash Calibration Done**

Set to 1 when the CALIB field has been updated by the Flash fuses after power-on reset or when the Flash fuses are reprogrammed. The CALIB field will not be updated again by the Flash fuses until a new power-on reset or the FCD field is written to zero.

## 13.6.14 PM Voltage Regulator Calibration Register

**Register name** VREGCR  
**Register access** Read/Write

31	30	29	28	27	26	25	24
KEY							
23	22	21	20	19	18	17	16
-	-	-	-	-	-	-	FCD
15	14	13	12	11	10	9	8
-	-	-	-	-	-	-	-
7	6	5	4	3	2	1	0
-	-	-	-	-	CALIB		

- **KEY: Register Write protection**  
 This field must be written twice, first with key value 0x55, then 0xAA, for a write operation to have an effect.
- **CALIB: Calibration value**  
 Calibration value for Voltage Regulator. See Electrical Characteristics for voltage values.
- **FCD: Flash Calibration Done**  
 Set to 1 when the CALIB field has been updated by the Flash fuses after power-on reset or when the Flash fuses are reprogrammed. The CALIB field will not be updated again by the Flash fuses until a new power-on reset or the FCD field is written to zero.

## 13.6.15 General Purpose Low-power register 0/1

**Register name** GPLP0,1  
**Register access** Read/Write

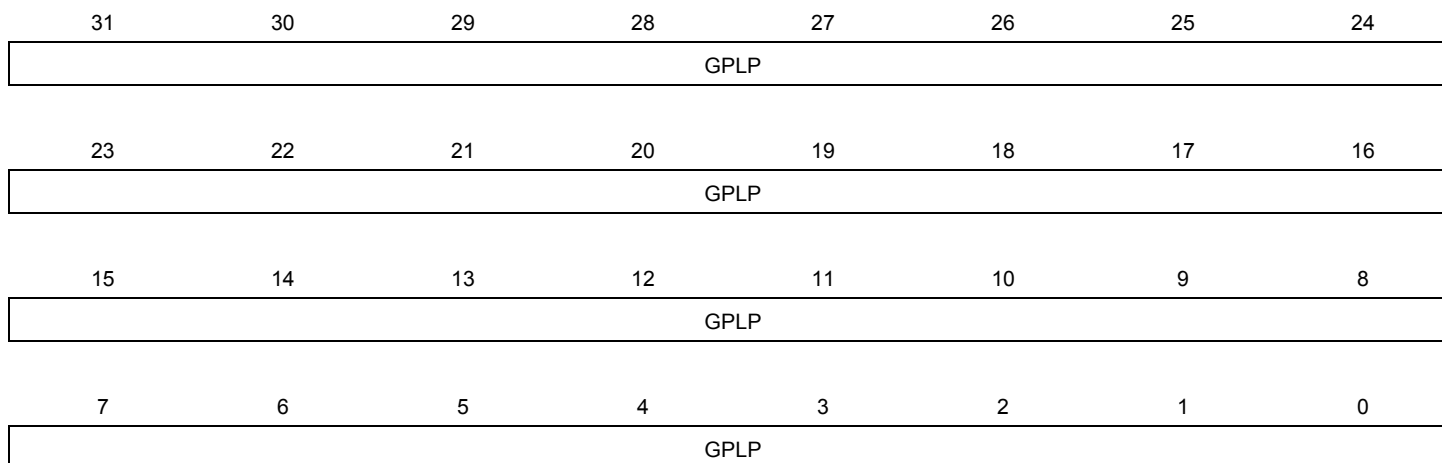

These registers are general purpose 32-bit registers that are reset only by power-on-reset. Any other reset will keep the content of these registers untouched.

## 14. Real Time Counter (RTC)

Rev: 2.3.0.1

### 14.1 Features

- 32-bit real-time counter with 16-bit prescaler
- Clocked from RC oscillator or 32 KHz oscillator
- High resolution: Max count frequency 16 KHz
- Long delays
  - Max timeout 272 years
- Extremely low power consumption
- Available in all sleep modes except Static
- Interrupt on wrap

### 14.2 Description

The Real Time Counter (RTC) enables periodic interrupts at long intervals, or accurate measurement of real-time sequences. The RTC is fed from a 16-bit prescaler, which is clocked from the RC oscillator or the 32 KHz oscillator. Any tapping of the prescaler can be selected as clock source for the RTC, enabling both high resolution and long timeouts. The prescaler cannot be written directly, but can be cleared by the user.

The RTC can generate an interrupt when the counter wraps around the value stored in the top register, producing accurate periodic interrupts.

## 14.3 Block Diagram

Figure 14-1. Real Time Counter module block diagram

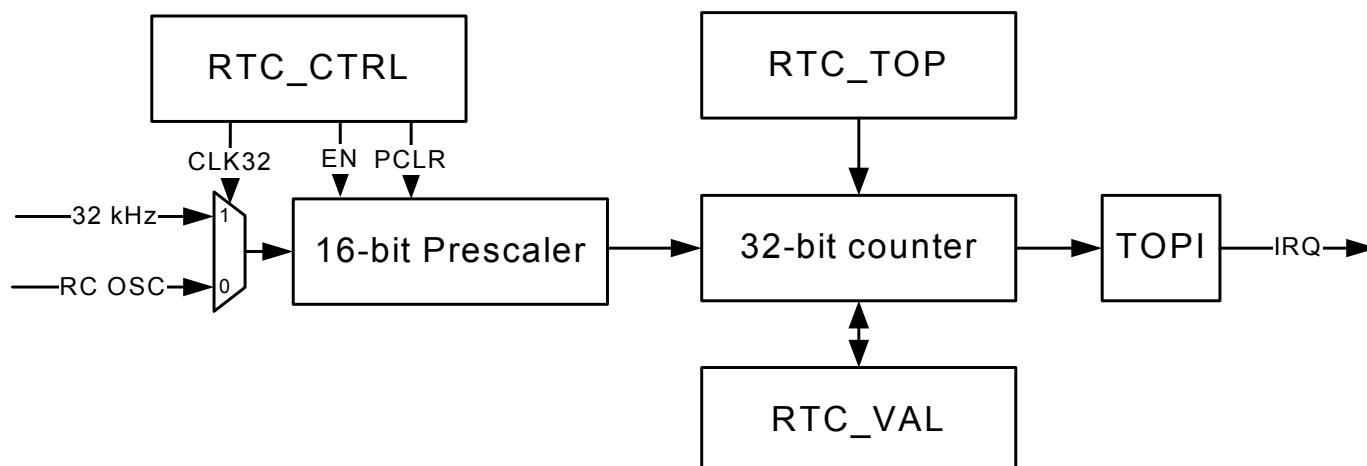

## 14.4 Product Dependencies

### 14.4.1 Power Management

The RTC is continuously clocked, and remains operating in all sleep modes except Static. Interrupts are not available in DeepStop mode.

### 14.4.2 Interrupt

The RTC interrupt line is connected to one of the internal sources of the interrupt controller. Using the RTC interrupt requires the interrupt controller to be programmed first.

### 14.4.3 Debug Operation

The RTC prescaler is frozen during debug operation, unless the OCD system keeps peripherals running in debug operation.

### 14.4.4 Clocks

The RTC can use the internal RC oscillator as clock source. This oscillator is always enabled whenever these modules are active. Please refer to the Electrical Characteristics chapter for the characteristic frequency of this oscillator ( $f_{RC}$ ).

The RTC can also use the 32 KHz crystal oscillator as clock source. This oscillator must be enabled before use. Please refer to the Power Manager chapter for details.

## 14.5 Functional Description

### 14.5.1 RTC operation

#### 14.5.1.1 Source clock

The RTC is enabled by writing the EN bit in the CTRL register to 1. The 16-bit prescaler will then increment on the selected clock. The prescaler cannot be read or written, but it can be reset by writing the PCLR strobe.

The CLK32 bit selects either the RC oscillator or the 32 KHz oscillator as clock source for the prescaler.

The PSEL bitfield selects the prescaler tapping, selecting the source clock for the RTC:

$$f_{\text{RTC}} = 2^{-(\text{PSEL}+1)} * (f_{\text{RC}} \text{ or } 32 \text{ KHz})$$

#### 14.5.1.2 Counter operation

When enabled, the RTC will increment until it reaches TOP, and then wrap to 0x0. The status bit TOPI in ISR is set when this occurs. From 0x0 the counter will count TOP+1 cycles of the source clock before it wraps back to 0x0.

The RTC count value can be read from or written to the register VAL. Due to synchronization, continuous reading of the VAL with the lowest prescaler setting will skip every other value.

#### 14.5.1.3 RTC Interrupt

Writing the TOPI bit in IER enables the RTC interrupt, while writing the corresponding bit in IDR disables the RTC interrupt. IMR can be read to see whether or not the interrupt is enabled. If enabled, an interrupt will be generated if the TOPI flag in ISR is set. The flag can be cleared by writing TOPI in ICR to one.

The RTC interrupt can wake the CPU from all sleep modes except DeepStop and Static mode.

#### 14.5.1.4 RTC wakeup

The RTC can also wake up the CPU directly without triggering an interrupt when the TOPI flag in ISR is set. In this case, the CPU will continue executing from the instruction following the sleep instruction.

This direct RTC wakeup is enabled by writing the WAKE\_EN bit in the CTRL register to one. When the CPU wakes from sleep, the WAKE\_EN bit must be written to zero to clear the internal wake signal to the sleep controller, otherwise a new sleep instruction will have no effect.

The RTC wakeup is available in all sleep modes except Static mode. The RTC wakeup can be configured independently of the RTC interrupt.

#### 14.5.1.5 Busy bit

Due to the crossing of clock domains, the RTC uses a few clock cycles to propagate the values stored in CTRL, TOP, and VAL to the RTC. The BUSY bit in CTRL indicates that a register write is still going on and all writes to TOP, CTRL, and VAL will be discarded until BUSY goes low again.



## 14.6 User Interface

Offset	Register	Register Name	Access	Reset
0x00	RTC Control	CTRL	Read/Write	0x0
0x04	RTC Value	VAL	Read/Write	0x0
0x08	RTC Top	TOP	Read/Write	0x0
0x10	RTC Interrupt Enable	IER	Write-only	0x0
0x14	RTC Interrupt Disable	IDR	Write-only	0x0
0x18	RTC Interrupt Mask	IMR	Read-only	0x0
0x1C	RTC Interrupt Status	ISR	Read-only	0x0
0x20	RTC Interrupt Clear	ICR	Write-only	0x0

### 14.6.1 RTC Control

**Name:** CTRL

**Access Type:** Read/Write

31	30	29	28	27	26	25	24
-	-	-	-	-	-	-	-
23	22	21	20	19	18	17	16
-	-	-	-	-	-	-	CLKEN
15	14	13	12	11	10	9	8
-	-	-	-	PSEL			
7	6	5	4	3	2	1	0
-	-	-	BUSY	CLK32	WAKE_EN	PCLR	EN

- **CLKEN: Clock enable**
  - 0: The clock is disabled
  - 1: The clock is enabled
- **PSEL: Prescale Select**
  - Selects prescaler bit PSEL as source clock for the RTC.
- **BUSY: RTC busy**
  - 0: The RTC accepts writes to TOP, VAL, and CTRL.
  - 1: The RTC is busy and will discard writes to TOP, VAL, and CTRL.
- **CLK32: 32 KHz oscillator select**
  - 0: The RTC uses the RC oscillator as clock source
  - 1: The RTC uses the 32 KHz oscillator as clock source

- **WAKE\_EN: Wakeup enable**
  - 0: The RTC does not wake up the CPU from sleep modes
  - 1: The RTC wakes up the CPU from sleep modes.
- **PCLR: Prescaler Clear**
  - Writing 1 to this strobe clears the prescaler.
- **EN: Enable**
  - 0: The RTC is disabled
  - 1: The RTC is enabled

## 14.6.2 RTC Value

**Name:** VAL

**Access Type:** Read/Write

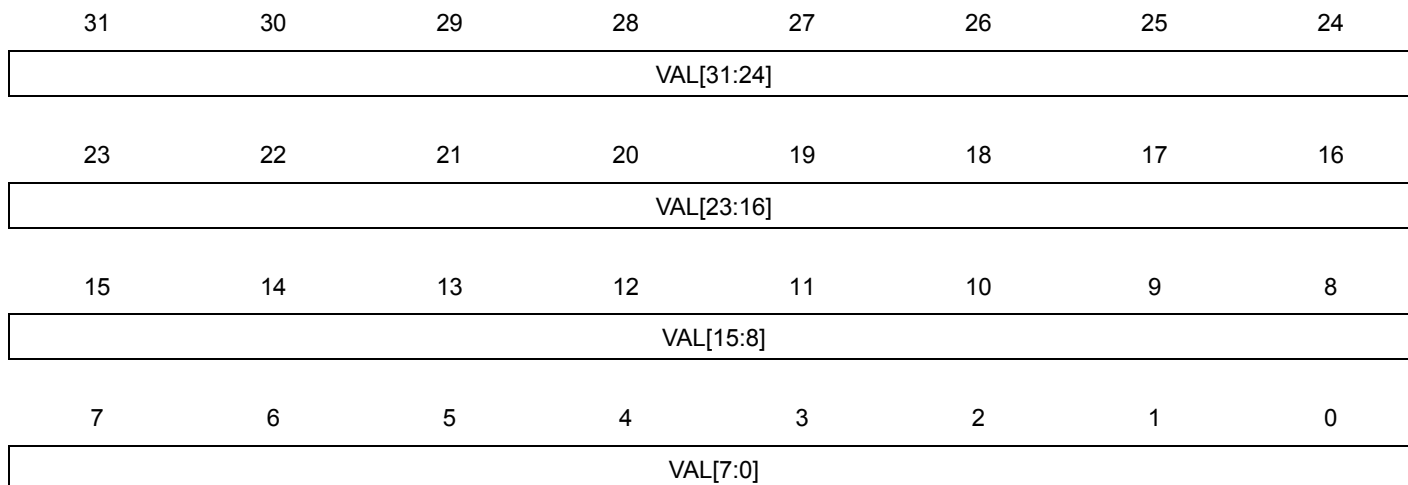

- **VAL: RTC Value**

This value is incremented on every rising edge of the source clock.

14.6.3 RTC Top

Name: TOP

Access Type: Read/Write

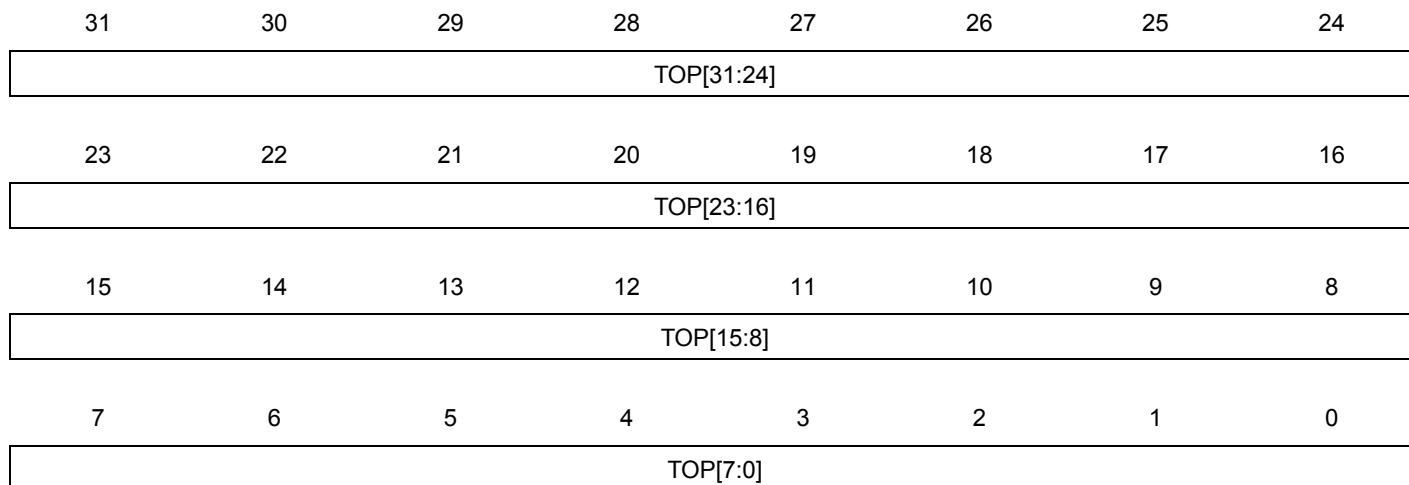

- **TOP: RTC Top Value**  
VAL wraps at this value.

## 14.6.4 RTC Interrupt Enable/Disable/Mask/Status/Clear

**Name:** IER/IDR/IMR/ISR/ICR

**Access Type:** IER/IDR/ICR: Write-only

IMR/ISR: Read-only

31	30	29	28	27	26	25	24
-	-	-	-	-	-	-	-
23	22	21	20	19	18	17	16
-	-	-	-	-	-	-	-
15	14	13	12	11	10	9	8
-	-	-	-	-	-	-	-
7	6	5	4	3	2	1	0
-	-	-	-	-	-	-	TOPI

- **TOPI: Top Interrupt**

VAL has wrapped at its top value.

The effect of writing or reading this bit depends on which register is being accessed:

- **IER (Write-only)**

0: No effect

1: Enable Interrupt

- **IDR (Write-only)**

0: No effect

1: Disable Interrupt

- **IMR (Read-only)**

0: Interrupt is disabled

1: Interrupt is enabled

- **ISR (Read-only)**

0: An interrupt event has occurred

1: An interrupt even has not occurred

- **ICR (Write-only)**

0: No effect

1: Clear interrupt even

## 15. Watchdog Timer (WDT)

Rev: 2.3.0.1

### 15.1 Features

- Watchdog Timer counter with 16-bit prescaler
- Clocked from RC oscillator

### 15.2 Description

The Watchdog Timer (WDT) has a prescaler generating a timeout period. This prescaler is clocked from the RC oscillator. The watchdog timer must be periodically reset by software within the timeout period, otherwise, the device is reset and starts executing from the boot vector. This allows the device to recover from a condition that has caused the system to be unstable.

### 15.3 Block Diagram

Figure 15-1. Watchdog Timer module block diagram

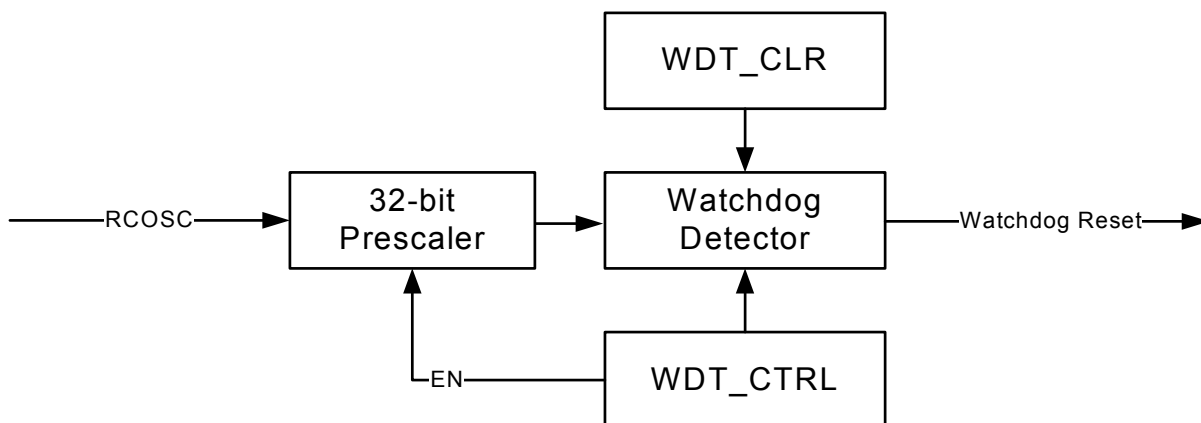

### 15.4 Product Dependencies

#### 15.4.1 Power Management

When the WDT is enabled, the WDT remains clocked in all sleep modes, and it is not possible to enter Static mode.

#### 15.4.2 Debug Operation

The WDT prescaler is frozen during debug operation, unless the OCD system keeps peripherals running in debug operation.

#### 15.4.3 Clocks

The WDT can use the internal RC oscillator as clock source. This oscillator is always enabled whenever these modules are active. Please refer to the Electrical Characteristics chapter for the characteristic frequency of this oscillator ( $f_{RC}$ ).

## 15.5 Functional Description

The WDT is enabled by writing the EN bit in the CTRL register to one. This also enables the RC clock for the prescaler. The PSEL bitfield in the same register selects the watchdog timeout period:

$$T_{\text{WDT}} = 2^{(\text{PSEL}+1)} / f_{\text{RC}}$$

The next timeout period will begin as soon as the watchdog reset has occurred and count down during the reset sequence. Care must be taken when selecting the PSEL value so that the timeout period is greater than the startup time of the chip, otherwise a watchdog reset can reset the chip before any code has been run.

To avoid accidental disabling of the watchdog, the CTRL register must be written twice, first with the KEY field set to 0x55, then 0xAA without changing the other bitfields. Failure to do so will cause the write operation to be ignored, and CTRL does not change value.

The CLR register must be written with any value with regular intervals shorter than the watchdog timeout period. Otherwise, the device will receive a soft reset, and the code will start executing from the boot vector.

When the WDT is enabled, it is not possible to enter Static mode. Attempting to do so will result in entering Shutdown mode, leaving the WDT operational.

## 15.6 User Interface

Offset	Register	Register Name	Access	Reset
0x00	WDT Control	CTRL	Read/Write	0x0
0x04	WDT Clear	CLR	Write-only	0x0



## 15.6.1 WDT Control

**Name:** CTRL

**Access Type:** Read/Write

31	30	29	28	27	26	25	24	
KEY[7:0]								
23	22	21	20	19	18	17	16	
-	-	-	-	-	-	-	-	
15	14	13	12	11	10	9	8	
-	-	-	PSEL					-
7	6	5	4	3	2	1	0	
-	-	-	-	-	-	-	EN	

- **KEY**

This bitfield must be written twice, first with key value 0x55, then 0xAA, for a write operation to be effective. This bitfield always reads as zero.

- **PSEL: Prescale Select**

Prescaler bit PSEL is used as watchdog timeout period.

- **EN: WDT Enable**

0: WDT is disabled.

1: WDT is enabled.

**15.6.2 WDT Clear****Name:** CLR**Access Type:** Write-only

When the watchdog timer is enabled, this register must be periodically written, with any value, within the watchdog timeout period, to prevent a watchdog reset.

## 16. Interrupt Controller (INTC)

Rev: 1.0.1.1

### 16.1 Description

The INTC collects interrupt requests from the peripherals, prioritizes them, and delivers an interrupt request and an autovector to the CPU. The AVR32 architecture supports 4 priority levels for regular, maskable interrupts, and a Non-Maskable Interrupt (NMI).

The INTC supports up to 64 groups of interrupts. Each group can have up to 32 interrupt request lines, these lines are connected to the peripherals. Each group has an Interrupt Priority Register (IPR) and an Interrupt Request Register (IRR). The IPRs are used to assign a priority level and an autovector to each group, and the IRRs are used to identify the active interrupt request within each group. If a group has only one interrupt request line, an active interrupt group uniquely identifies the active interrupt request line, and the corresponding IRR is not needed. The INTC also provides one Interrupt Cause Register (ICR) per priority level. These registers identify the group that has a pending interrupt of the corresponding priority level. If several groups have an pending interrupt of the same level, the group with the lowest number takes priority.

### 16.2 Block Diagram

Figure 16-1 on page 99 gives an overview of the INTC. The grey boxes represent registers that can be accessed via the Peripheral Bus (PB). The interrupt requests from the peripherals (IREQn) and the NMI are input on the left side of the figure. Signals to and from the CPU are on the right side of the figure.

Figure 16-1. Overview of the Interrupt Controller

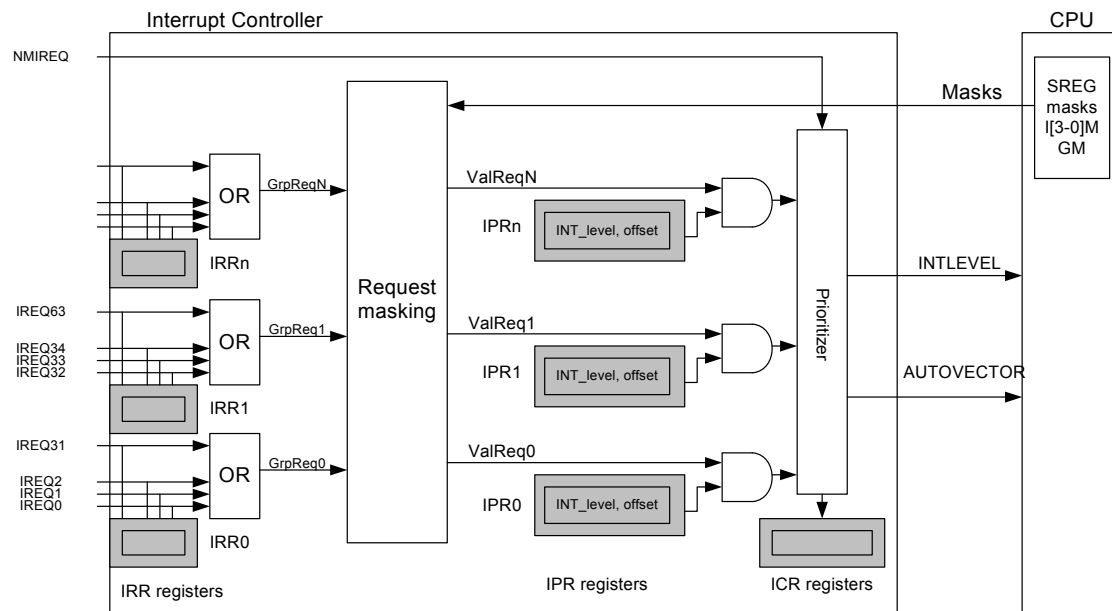

### 16.3 Operation

All of the incoming interrupt requests (IREQs) are sampled into the corresponding Interrupt Request Register (IRR). The IRRs must be accessed to identify which IREQ within a group that is active. If several IREQs within the same group is active, the interrupt service routine must pri-

oritize between them. All of the input lines in each group are logically-ORed together to form the GrpReqN lines, indicating if there is a pending interrupt in the corresponding group.

The Request Masking hardware maps each of the GrpReq lines to a priority level from INT0 to INT3 by associating each group with the INTLEVEL field in the corresponding IPR register. The GrpReq inputs are then masked by the I0M, I1M, I2M, I3M and GM mask bits from the CPU status register. Any interrupt group that has a pending interrupt of a priority level that is not masked by the CPU status register, gets its corresponding ValReq line asserted.

The Prioritizer hardware uses the ValReq lines and the INTLEVEL field in the IPRs to select the pending interrupt of the highest priority. If a NMI interrupt is pending, it automatically gets highest priority of any pending interrupt. If several interrupt groups of the highest pending interrupt level have pending interrupts, the interrupt group with the highest number is selected.

Interrupt level (INTLEVEL) and handler autovector offset (AUTOVECTOR) of the selected interrupt are transmitted to the CPU for interrupt handling and context switching. The CPU doesn't need to know which interrupt is requesting handling, but only the level and the offset of the handler address. The IRR registers contain the interrupt request lines of the groups and can be read via PB for checking which interrupts of the group are actually active.

Masking of the interrupt requests is done based on five interrupt mask bits of the CPU status register, namely interrupt level 3 mask (I3M) to interrupt level 0 mask (I0M), and Global interrupt mask (GM). An interrupt request is masked if either the Global interrupt mask or the corresponding interrupt level mask bit is set.

### 16.3.1 Non maskable interrupts

A NMI request has priority over all other interrupt requests. NMI has a dedicated exception vector address defined by the AVR32 architecture, so AUTOVECTOR is undefined when INTLEVEL indicates that an NMI is pending.

### 16.3.2 CPU response

When the CPU receives an interrupt request it checks if any other exceptions are pending. If no exceptions of higher priority are pending, interrupt handling is initiated. When initiating interrupt handling, the corresponding interrupt mask bit is set automatically for this and lower levels in status register. E.g, if interrupt on level 3 is approved for handling the interrupt mask bits I3M, I2M, I1M, and I0M are set in status register. If interrupt on level 1 is approved the masking bits I1M, and I0M are set in status register. The handler offset is calculated from AUTOVECTOR and EVBA and a change-of-flow to this address is performed.

Setting of the interrupt mask bits prevents the interrupts from the same and lower levels to be passed through the interrupt controller. Setting of the same level mask bit prevents also multiple request of the same interrupt to happen.

It is the responsibility of the handler software to clear the interrupt request that caused the interrupt before returning from the interrupt handler. If the conditions that caused the interrupt are not cleared, the interrupt request remains active.

### 16.3.3 Clearing an interrupt request

Clearing of the interrupt request is done by writing to registers in the corresponding peripheral module, which then clears the corresponding NMIREQ/IREQ signal.

The recommended way of clearing an interrupt request is a store operation to the controlling peripheral register, followed by a dummy load operation from the same register. This causes a

pipeline stall, which prevents the interrupt from accidentally re-triggering in case the handler is exited and the interrupt mask is cleared before the interrupt request is cleared.

## 16.4 User Interface

This chapter lists the INTC registers accessible through the PB bus. The registers are used to control the behaviour and read the status of the INTC.

### 16.4.1 Memory Map

The following table shows the address map of the INTC registers, relative to the base address of the INTC.

**Table 16-1.** INTC address map

Offset	Register	Name	Access	Reset Value
0	Interrupt Priority Register 0	IPR0	Read/Write	0x0000_0000
4	Interrupt Priority Register 1	IPR1	Read/Write	0x0000_0000
...	...	...	...	...
252	Interrupt Priority Register 63	IPR63	Read/Write	0x0000_0000
256	Interrupt Request Register 0	IRR0	Read-only	N/A
260	Interrupt Request Register 1	IRR1	Read-only	N/A
...	...	...	...	...
508	Interrupt Request Register 63	IRR63	Read-only	N/A
512	Interrupt Cause Register 3	ICR3	Read-only	N/A
516	Interrupt Cause Register 2	ICR2	Read-only	N/A
520	Interrupt Cause Register 1	ICR1	Read-only	N/A
524	Interrupt Cause Register 0	ICR0	Read-only	N/A

### 16.4.2 Interrupt Request Map

The mapping of interrupt requests from peripherals to INTREQs is presented in the Peripherals Section.

## 16.4.3 Interrupt Request Registers

Register Name: IRR0...IRR63

Access Type: Read-only

31	30	29	28	27	26	25	24
IRR(32*x+31)	IRR(32*x+30)	IRR(32*x+29)	IRR(32*x+28)	IRR(32*x+27)	IRR(32*x+26)	IRR(32*x+25)	IRR(32*x+24)
23	22	21	20	19	18	17	16
IRR(32*x+23)	IRR(32*x+22)	IRR(32*x+21)	IRR(32*x+20)	IRR(32*x+19)	IRR(32*x+18)	IRR(32*x+17)	IRR(32*x+16)
15	14	13	12	11	10	9	8
IRR(32*x+15)	IRR(32*x+14)	IRR(32*x+13)	IRR(32*x+12)	IRR(32*x+11)	IRR(32*x+10)	IRR(32*x+9)	IRR(32*x+8)
7	6	5	4	3	2	1	0
IRR(32*x+7)	IRR(32*x+6)	IRR(32*x+5)	IRR(32*x+4)	IRR(32*x+3)	IRR(32*x+2)	IRR(32*x+1)	IRR(32*x+0)

- **IRR: Interrupt Request line**

0 = No interrupt request is pending on this input request input.

1 = An interrupt request is pending on this input request input.

The are 64 IRRs, one for each group. Each IRR has 32 bits, one for each possible interrupt request, for a total of 2048 possible input lines. The IRRs are read by the software interrupt handler in order to determine which interrupt request is pending. The IRRs are sampled continuously, and are read-only.

## 16.4.4 Interrupt Priority Registers

Register Name: IPR0...IPR63

Access Type: Read/Write

31	30	29	28	27	26	25	24
INTLEVEL[1:0]		-	-	-	-	-	-
23	22	21	20	19	18	17	16
-	-	-	-	-	-	-	-
15	14	13	12	11	10	9	8
-	-	AUTOVECTOR[13:8]					
7	6	5	4	3	2	1	0
AUTOVECTOR[7:0]							

- INTLEVEL: Interrupt level associated with this group**

Indicates the EVBA-relative offset of the interrupt handler of the corresponding group:

INTLEVEL[1:0]		Priority
0	0	INT0
0	1	INT1
1	0	INT2
1	1	INT3

- AUTOVECTOR: Autovector address for this group**

Handler offset is used to give the address of the interrupt handler. The least significant bit should be written to zero to give halfword alignment

16.4.5 Interrupt Cause Registers

Register Name: ICR0...ICR3

Access Type: Read-only

31	30	29	28	27	26	25	24	
-	-	-	-	-	-	-	-	
23	22	21	20	19	18	17	16	
-	-	-	-	-	-	-	-	
15	14	13	12	11	10	9	8	
-	-	-	-	-	-	-	-	
7	6	5	4	3	2	1	0	
-	-	CAUSE						

- **CAUSE:** Interrupt group causing interrupt of priority n

ICRn identifies the group with the highest priority that has a pending interrupt of level n. If no interrupts of level n are pending, or the priority level is masked, the value of ICRn is UNDEFINED.



## 17. External Interrupts Controller (EIC)

Rev: 2.3.0.2

### 17.1 Features

- **Dedicated interrupt requests for each interrupt**
- **Individually maskable interrupts**
- **Interrupt on rising or falling edge**
- **Interrupt on high or low level**
- **Asynchronous interrupts for sleep modes without clock**
- **Filtering of interrupt lines**
- **Keypad scan support**
- **Maskable NMI interrupt**

### 17.2 Description

The External Interrupt Module allows pins to be configured as external interrupts. Each pin has its own interrupt request and can be individually masked. Each pin can generate an interrupt on rising or falling edge, or high or low level. Every line has a configurable filter too remove spikes on the interrupt lines. Every interrupt pin can also be configured to be asynchronous to wake up the part from sleep modes where the clock has been disabled.

A Non-Maskable Interrupt (NMI) is also supported. This has the same properties as the other external interrupts, but is connected to the NMI request of the CPU, enabling it to interrupt any other interrupt mode.

The External Interrupt Module has support for keypad scanning for keypads laid out in rows and columns. Columns are driven by a separate set of scanning outputs, while rows are sensed by the external interrupt lines. The pressed key will trigger an interrupt, which can be identified through the user registers of the module.

The External Interrupt Module can wake up the part from sleep modes without triggering an interrupt. In this mode, code execution starts from the instruction following the sleep instruction.

### 17.3 Block Diagram

Figure 17-1. External Interrupt Module block diagram

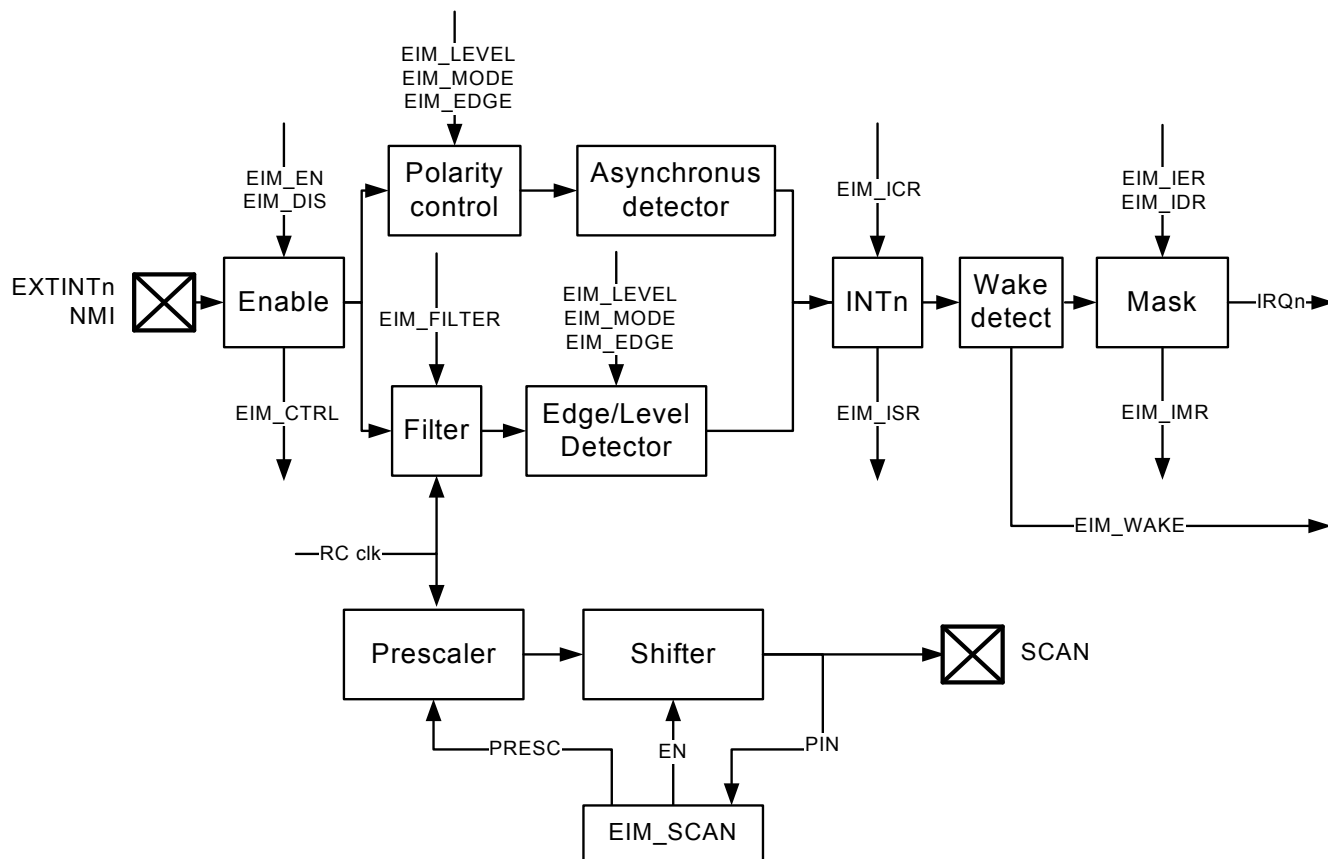

### 17.4 Product Dependencies

#### 17.4.1 I/O Lines

The External Interrupt and keypad scan pins are multiplexed with PIO lines. To act as external interrupts, these pins must be configured as input pins by the PIO controller. It is also possible to trigger the interrupt by driving these pins from registers in the PIO controller, or another peripheral output connected to the same pin.

#### 17.4.2 Power Management

All interrupts are available in every sleep mode. However, in sleep modes where the clock is stopped, asynchronous interrupts must be selected.

#### 17.4.3 Interrupt

The external interrupt lines are connected to internal sources of the interrupt controller. Using the external interrupts requires the interrupt controller to be programmed first.

Using the Non-Maskable Interrupt does not require the interrupt controller to be programmed.

## 17.5 Functional Description

### 17.5.1 External Interrupts

To enable an external interrupt EXTINTn must be written to 1 in register EN. Similarly, writing EXTINTn to 1 in register DIS disables the interrupt. The status of each Interrupt line can be observed in the CTRL register.

Each external interrupt pin EXTINTn can be configured to produce an interrupt on rising or falling edge, or high or low level. External interrupts are configured by the MODE, EDGE, and LEVEL registers. Each interrupt n has a bit INTn in each of these registers.

Similarly, each interrupt has a corresponding bit in each of the interrupt control and status registers. Writing 1 to the INTn strobe in IER enables the external interrupt on pin EXTINTn, while writing 1 to INTn in IDR disables the external interrupt. IMR can be read to check which interrupts are enabled. When the interrupt triggers, the corresponding bit in ISR will be set. The flag remains set until the corresponding strobe bit in ICR is written to 1.

Writing INTn in MODE to 0 enables edge triggered interrupts, while writing the bit to 1 enables level triggered interrupts.

If EXTINTn is configured as an edge triggered interrupt, writing INTn in EDGE to 0 will trigger the interrupt on falling edge, while writing the bit to 1 will trigger the interrupt on rising edge.

If EXTINTn is configured as a level triggered interrupt, writing INTn in LEVEL to 0 will trigger the interrupt on low level, while writing the bit to 1 will trigger the interrupt on high level.

To remove spikes that are longer than the clock period in the current mode each external interrupt contains a filter that can be enabled by writing 1 to INTn to FILTER.

Each interrupt line can be made asynchronous by writing 1 to INTn in the ASYNC register. This will route the interrupt signal through the asynchronous path of the module. All edge interrupts will be interpreted as level interrupts and the filter is disabled.

#### 17.5.1.1 Synchronization of external interrupts

The pin value of the EXTINTn pins is normally synchronized to the CPU clock, so spikes shorter than a CPU clock cycle are not guaranteed to produce an interrupt. In Stop mode, spikes shorter than a 32 KHz clock cycle are not guaranteed to produce an interrupt.

In Static mode, only unsynchronized interrupts remain active, and any short spike on this interrupt will wake up the device.

#### 17.5.1.2 Wakeup

The External interrupts can be used to wake up the part from sleep modes. The wakeup can be interpreted in two ways. If the corresponding bit in IMR is set, then the execution starts at the interrupt handler for this interrupt. If the bit in IMR is not set, then the execution starts from the next instruction after the sleep instruction.

### 17.5.2 Non-Maskable Interrupt

The NMI supports the same features as the external interrupts, and is accessed through the same registers. The description in [Section 17.5.1](#) should be followed, accessing the NMI bit instead of the INTn bits.

The NMI is non-maskable within the CPU in the sense that it can interrupt any other execution mode. Still, as for the other external interrupts, the actual NMI input line can be enabled and disabled by accessing the registers in the External Interrupt Module. These interrupts are not enabled by default, allowing the proper interrupt vectors to be set up by the CPU before the interrupts are enabled.

### 17.5.3 Keypad scan support

The External Interrupt Module also includes support for keypad scanning. The keypad scan feature is compatible with keypads organized as rows and columns, where a row is shorted against a column when a key is pressed.

The rows should be connected to the external interrupt pins with pullups enabled in the GPIO module. These external interrupts should be enabled as low level or falling edge interrupts. The columns should be connected to the available scan pins. The GPIO must be configured to let the required scan pins be controlled by the EIC module. Unused external interrupt or scan pins can be left controlled by the GPIO or other peripherals.

The Keypad Scan function is enabled by writing `:EN` to 1, which starts the keypad scan counter. The SCAN outputs are tristated, except `SCAN[0]`, which is driven to zero. After  $2^{(\text{SCAN:PRESC}+1)}$  RC clock cycles this pattern is left shifted, so that `SCAN[1]` is driven to zero while the other outputs are tristated. This sequence repeats infinitely, wrapping from the most significant SCAN pin to `SCAN[0]`.

When a key is pressed, the pulled-up row is driven to zero by the column, and an external interrupt triggers. The scanning stops, and the software can then identify the key pressed by the interrupt status register and the `SCAN:PINS` value.

The scanning stops whenever there is an active interrupt request from the EIC to the CPU. When the CPU clears the interrupt flags, scanning resumes.

## 17.6 User Interface

Offset	Register	Register Name	Access	Reset
0x00	EIC Interrupt Enable	IER	Write-only	0x0
0x04	EIC Interrupt Disable	IDR	Write-only	0x0
0x08	EIC Interrupt Mask	IMR	Read-only	0x0
0x0C	EIC Interrupt Status	ISR	Read-only	0x0
0x10	EIC Interrupt Clear	ICR	Write-only	0x0
0x14	External Interrupt Mode	MODE	Read/Write	0x0
0x18	External Interrupt Edge	EDGE	Read/Write	0x0
0x1C	External Interrupt Level	LEVEL	Read/Write	0x0
0x20	External Interrupt Filter	FILTER	Read/Write	0x0
0x24	External Interrupt Test	TEST	Read/Write	0x0
0x28	External Interrupt Asynchronous	ASYNC	Read/Write	0x0
0x2C	External Interrupt Scan	SCAN	Read/Write	0x0
0x30	External Interrupt Enable	EN	Write-only	0x0
0x34	External Interrupt Disable	DIS	Write-only	0x0
0x38	External Interrupt Control	CTRL	Read/Write	0x0

## 17.6.1 EIC Interrupt Enable/Disable/Mask/Status/Clear

**Name:** IER/IDR/IMR/ISR/ICR

**Access Type:** IER/IDR/ICR: Write-only

IMR/ISR: Read-only

31	30	29	28	27	26	25	24
-	-	-	-	-	-	-	-
23	22	21	20	19	18	17	16
-	-	-	-	-	-	-	-
15	14	13	12	11	10	9	8
-	-	-	-	-	-	-	NMI
7	6	5	4	3	2	1	0
INT7	INT6	INT5	INT4	INT3	INT2	INT1	INT0

The effect of writing or reading the bits listed above depends on which register is being accessed:

- **IER (Write-only)**
  - 0: No effect
  - 1: Enable Interrupt
- **IDR (Write-only)**
  - 0: No effect
  - 1: Disable Interrupt
- **IMR (Read-only)**
  - 0: Interrupt is disabled
  - 1: Interrupt is enabled
- **ISR (Read-only)**
  - 0: An interrupt event has occurred
  - 1: An interrupt even has not occurred
- **ICR (Write-only)**
  - 0: No effect
  - 1: Clear interrupt event

## 17.6.2 External Interrupt Mode/Edge/Level/Filter/Async

**Name:** MODE/EDGE/LEVEL/FILTER/ASYNC

**Access Type:** Read/Write

31	30	29	28	27	26	25	24
-	-	-	-	-	-	-	-
23	22	21	20	19	18	17	16
-	-	-	-	-	-	-	-
15	14	13	12	11	10	9	8
-	-	-	-	-	-	-	NMI
7	6	5	4	3	2	1	0
INT7	INT6	INT5	INT4	INT3	INT2	INT1	INT0

The bit interpretation is register specific:

- **MODE**

0: Interrupt is edge triggered

1: Interrupt is level triggered

- **EDGE**

0: Interrupt triggers on falling edge

1: Interrupt triggers on rising edge

- **LEVEL**

0: Interrupt triggers on low level

1: Interrupt triggers on high level

- **FILTER**

0: Interrupt is not filtered

1: Interrupt is filtered

- **ASYNC**

0: Interrupt is synchronized to the clock

1: Interrupt is asynchronous

## 17.6.3 External Interrupt Test

**Name:** TEST

**Access Type:** Read/Write

31	30	29	28	27	26	25	24
TEST_EN	-	-	-	-	-	-	-
23	22	21	20	19	18	17	16
-	-	-	-	-	-	-	-
15	14	13	12	11	10	9	8
-	-	-	-	-	-	-	NMI
7	6	5	4	3	2	1	0
INT7	INT6	INT5	INT4	INT3	INT2	INT1	INT0

- **NMI**

If TEST\_EN is 1, the value of this bit will be the value to the interrupt detector and the value on the pad will be ignored.

- **INTn**

If TEST\_EN is 1, the value of this bit will be the value to the interrupt detector and the value on the pad will be ignored.

- **TEST\_EN**

0: External interrupt test is disabled

1: External interrupt test is enabled



## 17.6.4 External Interrupt Scan

**Name:** SCAN

**Access Type:** Read/Write

31	30	29	28	27	26	25	24
-	-	-	-	-	PIN[2:0]		
23	22	21	20	19	18	17	16
-	-	-	-	-	-	-	-
15	14	13	12	11	10	9	8
-	-	-	PRESC[4:0]				
7	6	5	4	3	2	1	0
-	-	-	-	-	-	-	EN

- **EN**

0: Keypad scanning is disabled

1: Keypad scanning is enabled

- **PRESC**

Prescale select for the keypad scan rate:

$$\text{Scan rate} = 2^{(\text{SCAN:PRESC}+1)} T_{RC}$$

The RC clock period can be found in the Electrical Characteristics section.

- **PIN**

The index of the currently active scan pin. Writing to this bitfield has no effect.

## 17.6.5 External Interrupt Enable/Disable/Control

**Name:** EN/DIS/CTRL

**Access Type:** EN/DIS: Write-only

CTRL: Read-only

31	30	29	28	27	26	25	24
-	-	-	-	-	-	-	-
23	22	21	20	19	18	17	16
-	-	-	-	-	-	-	-
15	14	13	12	11	10	9	8
-	-	-	-	-	-	-	NMI
7	6	5	4	3	2	1	0
INT7	INT6	INT5	INT4	INT3	INT2	INT1	INT0

The bit interpretation is register specific:

- **EN**

0: No effect

1: Interrupt is enabled

- **DIS**

0: No effect

1: Interrupt is disabled

- **CTRL**

0: Interrupt is disabled

1: Interrupt is enabled

## 18. Flash Controller (FLASHC)

Rev: 2.0.0.2

### 18.1 Features

- Controls flash block with dual read ports allowing staggered reads.
- Supports 0 and 1 wait state bus access.
- Allows interleaved burst reads for systems with one wait state, outputting one 32-bit word per clock cycle.
- 32-bit HSB interface for reads from flash array and writes to page buffer.
- 32-bit PB interface for issuing commands to and configuration of the controller.
- 16 lock bits, each protecting a region consisting of (total number of pages in the flash block / 16) pages.
- Regions can be individually protected or unprotected.
- Additional protection of the Boot Loader pages.
- Supports reads and writes of general-purpose NVM bits.
- Supports reads and writes of additional NVM pages.
- Supports device protection through a security bit.
- Dedicated command for chip-erase, first erasing all on-chip volatile memories before erasing flash and clearing security bit.
- Interface to Power Manager for power-down of flash-blocks in sleep mode.

### 18.2 Description

The flash controller (FLASHC) interfaces a flash block with the 32-bit internal HSB bus. Performance for uncached systems with high clock-frequency and one wait state is increased by placing words with sequential addresses in alternating flash subblocks. Having one read interface per subblock allows them to be read in parallel. While data from one flash subblock is being output on the bus, the sequential address is being read from the other flash subblock and will be ready in the next clock cycle.

The controller also manages the programming, erasing, locking and unlocking sequences with dedicated commands.

### 18.3 Product dependencies

#### 18.3.1 Power management

The HFLASHC has two bus clocks connected: One High speed bus clock (CLK\_FLASHC\_HSB) and one Peripheral bus clock (CLK\_FLASHC\_PB). These clocks are generated by the Power manager. Both clocks are turned on by default, but the user has to ensure that CLK\_FLASHC\_HSB is not turned off before reading the flash or writing the page-buffer and that CLK\_FLASHC\_PB is not turned off before accessing the FLASHC configuration and control registers.

#### 18.3.2 Interrupt

The FLASHC interrupt lines are connected to internal sources of the interrupt controller. Using FLASHC interrupts requires the interrupt controller to be programmed first.

## 18.4 Functional description

### 18.4.1 Bus interfaces

The FLASHC has two bus interfaces, one High-Speed Bus (HSB) interface for reads from the flash array and writes to the page buffer, and one Peripheral Bus (PB) interface for writing commands and control to and reading status from the controller.

### 18.4.2 Memory organization

To maximize performance for high clock-frequency systems, FLASHC interfaces to a flash block with two read ports. The flash block has several parameters, given by the design of the flash block. Refer to the “Memories” chapter for the device-specific values of the parameters.

- $p$  pages (*FLASH\_P*)
- $w$  words in each page and in the page buffer (*FLASH\_W*)
- $pw$  words in total (*FLASH\_PW*)
- $f$  general-purpose fuse bits (*FLASH\_F*)
- 1 security fuse bit
- 1 User Page

### 18.4.3 User page

The User page is an additional page, outside the regular flash array, that can be used to store various data, like calibration data and serial numbers. This page is not erased by regular chip erase. The User page can only be written and erased by proprietary commands. Read accesses to the User page is performed just as any other read access to the flash. The address map of the User page is given in [Figure 18-1](#).

### 18.4.4 Read operations

The FLASHC provides two different read modes:

- 0 wait state (0ws) for clock frequencies  $<$  (access time of the flash plus the bus delay)
- 1 wait state (1ws) for clock frequencies  $<$  (access time of the flash plus the bus delay)/2

Higher clock frequencies that would require more wait states are not supported by the flash controller.

The programmer can select the wait states required by writing to the FWS field in the flash control register (FCR). It is the responsibility of the programmer to select a number of wait states compatible with the clock frequency and timing characteristics of the flash block.

In 0ws mode, only one of the two flash read ports is accessed. The other flash read port is idle. In 1ws mode, both flash read ports are active. One read port reading the addressed word, and the other reading the next sequential word.

If the clock frequency allows, the user should use 0ws mode, because this gives the lowest power consumption for low-frequency systems as only one flash read port is read. Using 1ws mode has a power/performance ratio approaching 0ws mode as the clock frequency approaches twice the max frequency of 0ws mode. Using two flash read ports use twice the power, but also give twice the performance.

The flash controller supports flash blocks with up to  $2^{21}$  word addresses, as displayed in [Figure 18-1](#). Reading the memory space between address  $pw$  and  $2^{21}-1$  returns an undefined result. The User page is permanently mapped to word address  $2^{21}$ .

**Table 18-1.** User row addresses

Memory type	Start address, byte sized	Size
Main array	0	$pw$ words = $4pw$ bytes
User	$2^{23} = 8388608$	128 words = 512 bytes

**Figure 18-1.** Memory map for the Flash memories

All addresses are word addresses

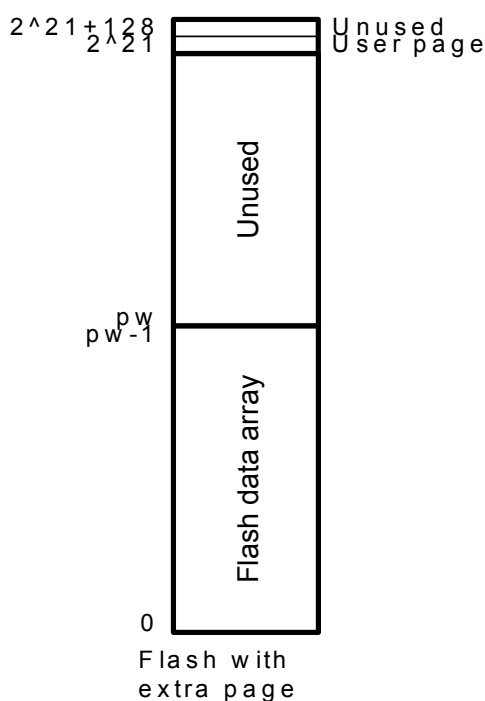

### 18.4.5 Quick Page Read

A dedicated command, Quick Page Read (QPR), is provided to read all words in an addressed page. All bits in all words in this page are AND'ed together, returning a 1-bit result. This result is placed in the Quick Page Read Result (QPRR) bit in Flash Status Register (FSR). The QPR command is useful to check that a page is in an erased state. The QPR instruction is much faster than performing the erased-page check using a regular software subroutine.

### 18.4.6 Write page buffer operations

The internal memory area reserved for the embedded flash can also be written through a write-only page buffer. The page buffer is addressed only by the address bits required to address  $w$  words (since the page buffer is word addressable) and thus wrap around within the internal memory area address space and appear to be repeated within it.

When writing to the page buffer, the PAGEN field in the FCMD register is updated with the page number corresponding to page address of the latest word written into the page buffer.

The page buffer is also used for writes to the User page.

Write operations can be prevented by programming the Memory Protection Unit of the CPU. Writing 8-bit and 16-bit data to the page buffer is not allowed and may lead to unpredictable data corruption.

Page buffer write operations are performed with 4 wait states.

Writing to the page buffer can only change page buffer bits from one to zero, ie writing 0xaaaaaaaa to a page buffer location that has the value 0x00000000, will not change the page buffer value. The only way to change a bit from zero to one, is to reset the entire page buffer with the Clear Page Buffer command.

The page buffer is not automatically reset after a page write. The programmer should do this manually by issuing the Clear Page Buffer flash command. This can be done after a page write, or before the page buffer is loaded with data to be stored to the flash page.

Example: Writing a word into word address 130 of a flash with 128 words in the page buffer. PAGEN will be updated with the value 1, and the word will be written into word 2 in the page buffer.

#### 18.4.7 Writing words to a page that is not completely erased

This can be used for EEPROM emulation, i.e. writes with granularity of one word instead of an entire page. Only words that are in an completely erased state (0xFFFFFFFF) can be changed. The procedure is as follows:

1. Clear page buffer
2. Write to the page buffer the result of the logical bitwise AND operation between the contents of the flash page and the new data to write. Only words that were in an erased state can be changed from the original page.
3. Write Page.

## 18.5 Flash commands

The FLASHC offers a command set to manage programming of the flash memory, locking and unlocking of regions, and full flash erasing. See chapter 18.8.3 for a complete list of commands.

To run a command, the field CMD of the Flash Command Register (FCMD) has to be written with the command number. As soon as the FCMD register is written, the FRDY flag is automatically cleared. Once the current command is complete, the FRDY flag is automatically set. If an interrupt has been enabled by setting the bit FRDY in FCR, the interrupt line of the flash controller is activated. All flash commands except for Quick Page Read (QPR) will generate an interrupt request upon completion if FRDY is set.

After a command has been written to FCMD, the programming algorithm should wait until the command has been executed before attempting to read instructions or data from the flash or writing to the page buffer, as the flash will be busy. The waiting can be performed either by polling the Flash Status Register (FSR) or by waiting for the flash ready interrupt. The command written to FCMD is initiated on the first clock cycle where the HSB bus interface in FLASHC is IDLE. The user must make sure that the access pattern to the FLASHC HSB interface contains an IDLE cycle so that the command is allowed to start. Make sure that no bus masters such as DMA controllers are performing endless burst transfers from the flash. Also, make sure that the CPU does not perform endless burst transfers from flash. This is done by

letting the CPU enter sleep mode after writing to FCMD, or by polling FSR for command completion. This polling will result in an access pattern with IDLE HSB cycles.

All the commands are protected by the same keyword, which has to be written in the eight highest bits of the FCMD register. Writing FCMD with data that does not contain the correct key and/or with an invalid command has no effect on the flash memory; however, the PROGE flag is set in the Flash Status Register (FSR). This flag is automatically cleared by a read access to the FSR register.

Writing a command to FCMD while another command is being executed has no effect on the flash memory; however, the PROGE flag is set in the Flash Status Register (FSR). This flag is automatically cleared by a read access to the FSR register.

If the current command writes or erases a page in a locked region, or a page protected by the BOOTPROT fuses, the command has no effect on the flash memory; however, the LOCKE flag is set in the FSR register. This flag is automatically cleared by a read access to the FSR register.

### 18.5.1 Write/erase page operation

Flash technology requires that an erase must be done before programming. The entire flash can be erased by an Erase All command. Alternatively, pages can be individually erased by the Erase Page command.

The User page can be written and erased using the mechanisms described in this chapter.

After programming, the page can be locked to prevent miscellaneous write or erase sequences. Locking is performed on a per-region basis, so locking a region locks all pages inside the region. Additional protection is provided for the lowermost address space of the flash. This address space is allocated for the Boot Loader, and is protected both by the lock bit(s) corresponding to this address space, and the BOOTPROT[2:0] fuses.

Data to be written are stored in an internal buffer called page buffer. The page buffer contains *w* words. The page buffer wraps around within the internal memory area address space and appears to be repeated by the number of pages in it. Writing of 8-bit and 16-bit data to the page buffer is not allowed and may lead to unpredictable data corruption.

Data must be written to the page buffer before the programming command is written to the Flash Command Register FCMD. The sequence is as follows:

- Reset the page buffer with the Clear Page Buffer command.
- Fill the page buffer with the desired contents, using only 32-bit access.
- Programming starts as soon as the programming key and the programming command are written to the Flash Command Register. The PAGEN field in the Flash Command Register (FCMD) must contain the address of the page to write. PAGEN is automatically updated when writing to the page buffer, but can also be written to directly. The FRDY bit in the Flash Status Register (FSR) is automatically cleared when the page write operation starts.
- When programming is completed, the bit FRDY in the Flash Status Register (FSR) is set. If an interrupt was enabled by setting the bit FRDY in FCR, the interrupt line of the flash controller is set.

Two errors can be detected in the FSR register after a programming sequence:

- Programming Error: A bad keyword and/or an invalid command have been written in the FCMD register.

- Lock Error: The page to be programmed belongs to a locked region. A command must be executed to unlock the corresponding region before programming can start.

### 18.5.2 Erase All operation

The entire memory is erased if the Erase All command (EA) is written to the Flash Command Register (FCMD). Erase All erases all bits in the flash array. The User page is not erased. All flash memory locations, the general-purpose fuse bits, and the security bit are erased (reset to 0xFF) after an Erase All.

The EA command also ensures that all volatile memories, such as register file and RAMs, are erased before the security bit is erased.

Erase All operation is allowed only if no regions are locked, and the BOOTPROT fuses are programmed with a region size of 0. Thus, if at least one region is locked, the bit LOCKE in FSR is set and the command is cancelled. If the bit LOCKE has been written to 1 in FCR, the interrupt line rises.

When the command is complete, the bit FRDY bit in the Flash Status Register (FSR) is set. If an interrupt has been enabled by setting the bit FRDY in FCR, the interrupt line of the flash controller is set. Two errors can be detected in the FSR register after issuing the command:

- Programming Error: A bad keyword and/or an invalid command have been written in the FCMD register.
- Lock Error: At least one lock region to be erased is protected, or BOOTPROT is different from 0. The erase command has been refused and no page has been erased. A Clear Lock Bit command must be executed previously to unlock the corresponding lock regions.

### 18.5.3 Region lock bits

The flash block has  $p$  pages, and these pages are grouped into 16 lock regions, each region containing  $p/16$  pages. Each region has a dedicated lock bit preventing writing and erasing pages in the region. After production, the device may have some regions locked. These locked regions are reserved for a boot or default application. Locked regions can be unlocked to be erased and then programmed with another application or other data.

To lock or unlock a region, the commands Lock Region Containing Page (LP) and Unlock Region Containing Page (UP) are provided. Writing one of these commands, together with the number of the page whose region should be locked/unlocked, performs the desired operation.

One error can be detected in the FSR register after issuing the command:

- Programming Error: A bad keyword and/or an invalid command have been written in the FCMD register.

The lock bits are implemented using the lowest 16 general-purpose fuse bits. This means that lock bits can also be set/cleared using the commands for writing/erasing general-purpose fuse bits, see chapter 18.6. The general-purpose bit being in an erased (1) state means that the region is unlocked.

The lowermost pages in the Flash can additionally be protected by the BOOTPROT fuses, see [Section 18.6](#).

## 18.6 General-purpose fuse bits

Each flash block has a number of general-purpose fuse bits that the application programmer can use freely. The fuse bits can be written and erased using dedicated commands, and read



through a dedicated Peripheral Bus address. Some of the general-purpose fuse bits are reserved for special purposes, and should not be used for other functions.:

**Table 18-2.** General-purpose fuses with special functions

General-Purpose fuse number	Name	Usage
15:0	LOCK	Region lock bits.
16	EPFL	<p>External Privileged Fetch Lock. Used to prevent the CPU from fetching instructions from external memories when in privileged mode. This bit can only be changed when the security bit is cleared. The address range corresponding to external memories is device-specific, and not known to the flash controller. This fuse bit is simply routed out of the CPU or bus system, the flash controller does not treat this fuse in any special way, except that it can not be altered when the security bit is set.</p> <p>If the security bit is set, only an external JTAG Chip Erase can clear EPFL. No internal commands can alter EPFL if the security bit is set.</p> <p>When the fuse is erased (i.e. "1"), the CPU can execute instructions fetched from external memories. When the fuse is programmed (i.e. "0"), instructions can not be executed from external memories.</p>
19:17	BOOTPROT	<p>Used to select one of four different bootloader sizes. Pages included in the bootloader area can not be erased or programmed except by a JTAG chip erase. BOOTPROT can only be changed when the security bit is cleared.</p> <p>If the security bit is set, only an external JTAG Chip Erase can clear BOOTPROT, and thereby allow the pages protected by BOOTPROT to be programmed. No internal commands can alter BOOTPROT or the pages protected by BOOTPROT if the security bit is set.</p>

The BOOTPROT fuses protects the following address space for the Boot Loader:

**Table 18-3.** Boot Loader area specified by BOOTPROT

BOOTPROT	Pages protected by BOOTPROT	Size of protected memory
7	None	0
6	0-1	1kByte
5	0-3	2kByte
4	0-7	4kByte
3	0-15	8kByte
2	0-31	16kByte
1	0-63	32kByte
0	0-127	64kByte

To erase or write a general-purpose fuse bit, the commands Write General-Purpose Fuse Bit (WGPB) and Erase General-Purpose Fuse Bit (EGPB) are provided. Writing one of these

commands, together with the number of the fuse to write/erase, performs the desired operation.

An entire General-Purpose Fuse byte can be written at a time by using the Program GP Fuse Byte (PGPFB) instruction. A PGPFB to GP fuse byte 2 is not allowed if the flash is locked by the security bit. The PFB command is issued with a parameter in the PAGEN field:

- PAGEN[2:0] - byte to write
- PAGEN[10:3] - Fuse value to write

All General-Purpose fuses can be erased by the Erase All General-Purpose fuses (EAGP) command. An EAGP command is not allowed if the flash is locked by the security bit.

Two errors can be detected in the FSR register after issuing these commands:

- Programming Error: A bad keyword and/or an invalid command have been written in the FCMD register.
- Lock Error: A write or erase of any of the special-function fuse bits in [Table 18-3](#) was attempted while the flash is locked by the security bit.

The lock bits are implemented using the lowest 16 general-purpose fuse bits. This means that the 16 lowest general-purpose fuse bits can also be written/erased using the commands for locking/unlocking regions, see [Section 18.5.3](#).

## 18.7 Security bit

The security bit allows the entire chip to be locked from external JTAG or other debug access for code security. The security bit can be written by a dedicated command, Set Security Bit (SSB). Once set, the only way to clear the security bit is through the JTAG Chip Erase command.

Once the Security bit is set, the following Flash controller commands will be unavailable and return a lock error if attempted:

- Write General-Purpose Fuse Bit (WGPB) to BOOTPROT or EPFL fuses
- Erase General-Purpose Fuse Bit (EGPB) to BOOTPROT or EPFL fuses
- Program General-Purpose Fuse Byte (PGPFB) of fuse byte 2
- Erase All General-Purpose Fuses (EAGPF)

One error can be detected in the FSR register after issuing the command:

- Programming Error: A bad keyword and/or an invalid command have been written in the FCMD register.

## 18.8 User interface

### 18.8.1 Address map

The following addresses are used by the FLASHC. All offsets are relative to the base address allocated to the flash controller.

**Table 18-4.** Flash controller register mapping

Offset	Register	Name	Access	Reset state
0x0	Flash Control Register	FCR	R/W	0
0x4	Flash Command Register	FCMD	R/W	0
0x8	Flash Status Register	FSR	R/W	0 (*)
0xc	Flash General Purpose Fuse Register Hi	FGPFRHI	R	NA (*)
0x10	Flash General Purpose Fuse Register Lo	FGPFRLO	R	NA (*)

(\*) The value of the Lock bits is dependent of their programmed state. All other bits in FSR are 0. All bits in FGPFR and FCFR are dependent on the programmed state of the fuses they map to. Any bits in these registers not mapped to a fuse read 0.

## 18.8.2 Flash Control Register (FCR)

Offset: 0x0

31	30	29	28	27	26	25	24
-	-	-	-	-	-	-	-
23	22	21	20	19	18	17	16
-	-	-	-	-	-	-	-
15	14	13	12	11	10	9	8
-	-	-	-	-	-	-	SASD
7	6	5	4	3	2	1	0
-	FWS	-	-	PROGE	LOCKE	-	FRDY

### FRDY: Flash Ready Interrupt Enable

0: Flash Ready does not generate an interrupt.

1: Flash Ready generates an interrupt.

### LOCKE: Lock Error Interrupt Enable

0: Lock Error does not generate an interrupt.

1: Lock Error generates an interrupt.

### PROGE: Programming Error Interrupt Enable

0: Programming Error does not generate an interrupt.

1: Programming Error generates an interrupt.

### FWS: Flash Wait State

0: The flash is read with 0 wait states.

1: The flash is read with 1 wait state.

### SASD: Sense Amplifier Sample Disable

0: The sense amplifiers in the flash are in sampling mode.

1: The sense amplifiers in the flash are permanently enabled. Consumes more power.

## 18.8.3 Flash Command Register (FCMD)

Offset: 0x4

The FCMD can not be written if the flash is in the process of performing a flash command. Doing so will cause the FCR write to be ignored, and the PROGE bit to be set.

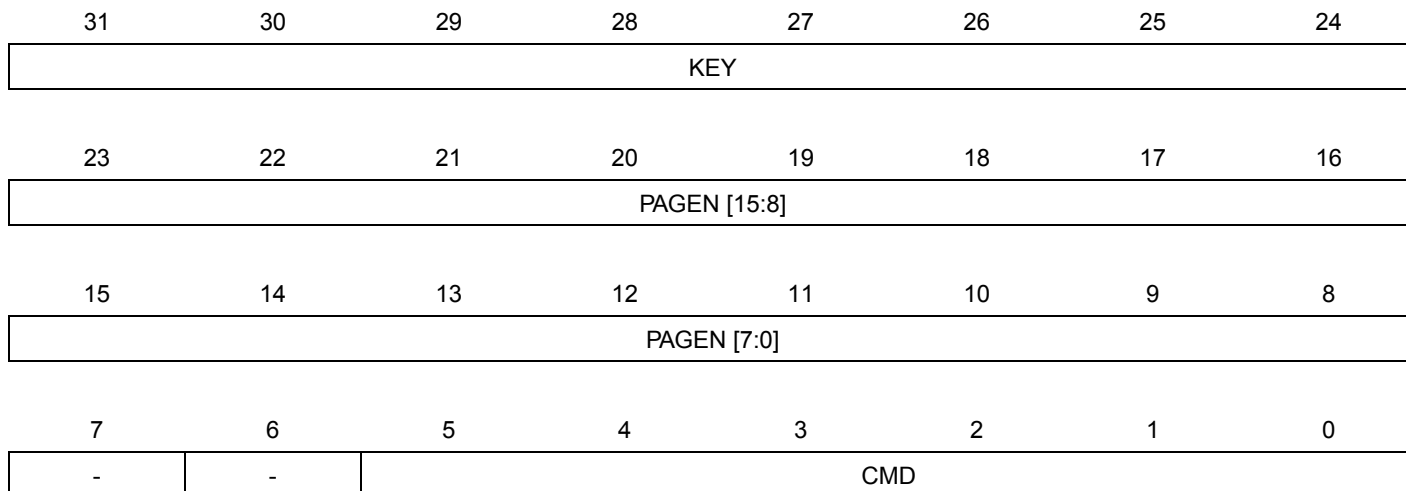

### CMD: Command

This field defines the flash command. Issuing any unused command will cause the Programming Error flag to be set, and the corresponding interrupt to be requested if the PROGE bit in FCR is set.

**Table 18-5.** Set of commands

Command	Value	Mnemonic
No operation	0	NOP
Write Page	1	WP
Erase Page	2	EP
Clear Page Buffer	3	CPB
Lock region containing given Page	4	LP
Unlock region containing given Page	5	UP
Erase All	6	EA
Write General-Purpose Fuse Bit	7	WGPB
Erase General-Purpose Fuse Bit	8	EGPB
Set Security Bit	9	SSB
Program GP Fuse Byte	10	PGPFB
Erase All GPFuses	11	EAGPF
Quick Page Read	12	QPR
Write User Page	13	WUP
Erase User Page	14	EUP
Quick Page Read User Page	15	QPRUP

## PAGEN: Page number

The PAGEN field is used to address a page or fuse bit for certain operations. In order to simplify programming, the PAGEN field is automatically updated every time the page buffer is written to. For every page buffer write, the PAGEN field is updated with the page number of the address being written to. Hardware automatically masks writes to the PAGEN field so that only bits representing valid page numbers can be written, all other bits in PAGEN are always 0. As an example, in a flash with 1024 pages (page 0 - page 1023), bits 15:10 will always be 0.

**Table 18-6.** Semantic of PAGEN field in different commands

Command	PAGEN description
No operation	Not used
Write Page	The number of the page to write
Clear Page Buffer	Not used
Lock region containing given Page	Page number whose region should be locked
Unlock region containing given Page	Page number whose region should be unlocked
Erase All	Not used
Write General-Purpose Fuse Bit	GPFUSE #
Erase General-Purpose Fuse Bit	GPFUSE #
Set Security Bit	Not used
Program GP Fuse Byte	WriteData[7:0], ByteAddress[2:0]
Erase All GP Fuses	Not used
Quick Page Read	Page number
Write User Page	Not used
Erase User Page	Not used
Quick Page Read User Page	Not used

## KEY: Write protection key

This field should be written with the value 0xA5 to enable the command defined by the bits of the register. If the field is written with a different value, the write is not performed and no action is started.

This field always reads as 0.

## 18.8.4 Flash Status Register (FSR)

Offset: 0x08

31	30	29	28	27	26	25	24
LOCK15	LOCK14	LOCK13	LOCK12	LOCK11	LOCK10	LOCK9	LOCK8
23	22	21	20	19	18	17	16
LOCK7	LOCK6	LOCK5	LOCK4	LOCK3	LOCK2	LOCK1	LOCK0
15	14	13	12	11	10	9	8
FSZ		-	-	-	-	-	-
7	6	5	4	3	2	1	0
-	-	QPRR	SECURITY	PROGE	LOCKE	-	FRDY

### FRDY: Flash Ready Status

0: The flash controller is busy and the application must wait before running a new command.

1: The flash controller is ready to run a new command.

### LOCKE: Lock Error Status

Automatically cleared when FSR is read.

0: No programming of at least one locked lock region has happened since the last read of FSR.

1: Programming of at least one locked lock region has happened since the last read of FSR.

### PROGE: Programming Error Status

Automatically cleared when FSR is read.

0: No invalid commands and no bad keywords were written in the Flash Command Register FCMD.

1: An invalid command and/or a bad keyword was/were written in the Flash Command Register FCMD.

### SECURITY: Security Bit Status

0: The security bit is inactive.

1: The security bit is active.

### QPRR: Quick Page Read Result

0: The result is zero, i.e. the page is not erased.

1: The result is one, i.e. the page is erased.

Automatically cleared when FSR is read.

**FSZ: Flash Size**

The size of the flash. Not all device families will provide all flash sizes indicated in the table.

**Table 18-7.** Flash size

<b>FSZ</b>	<b>Flash Size</b>
0	32 KByte
1	64 kByte
2	128 kByte
3	256 kByte
4	384 kByte
5	512 kByte
6	768 kByte
7	1024 kByte

**LOCKx: Lock Region x Lock Status**

0: The corresponding lock region is not locked.

1: The corresponding lock region is locked.



## 18.8.5 Flash General Purpose Fuse Register High (FGPFRHI)

Offset: 0x0C

31	30	29	28	27	26	25	24
GPF63	GPF62	GPF61	GPF60	GPF59	GPF58	GPF57	GPF56
23	22	21	20	19	18	17	16
GPF55	GPF54	GPF53	GPF52	GPF51	GPF50	GPF49	GPF48
15	14	13	12	11	10	9	8
GPF47	GPF46	GPF45	GPF44	GPF43	GPF42	GPF41	GPF40
7	6	5	4	3	2	1	0
GPF39	GPF38	GPF37	GPF36	GPF35	GPF34	GPF33	GPF32

This register is only used in systems with more than 32 GP fuses.

### **GPFxx: General Purpose Fuse xx**

0: The fuse has a written/programmed state.

1: The fuse has an erased state.

## 18.8.6 Flash General Purpose Fuse Register Low (FGPFRLO)

Offset: 0x10

31	30	29	28	27	26	25	24
GPF31	GPF30	GPF29	GPF28	GPF27	GPF26	GPF25	GPF24
23	22	21	20	19	18	17	16
GPF23	GPF22	GPF21	GPF20	GPF19	GPF18	GPF17	GPF16
15	14	13	12	11	10	9	8
GPF15	GPF14	GPF13	GPF12	GPF11	GPF10	GPF09	GPF08
7	6	5	4	3	2	1	0
GPF07	GPF06	GPF05	GPF04	GPF03	GPF02	GPF01	GPF00

### GPFxx: General Purpose Fuse xx

0: The fuse has a written/programmed state.

1: The fuse has an erased state.



## 19. HSB Bus Matrix (HMATRIX)

Rev: 2.3.0.1

### 19.1 Features

- User Interface on peripheral bus
- Configurable Number of Masters (Up to sixteen)
- Configurable Number of Slaves (Up to sixteen)
- One Decoder for Each Master
- Three Different Memory Mappings for Each Master (Internal and External boot, Remap)
- One Remap Function for Each Master
- Programmable Arbitration for Each Slave
  - Round-Robin
  - Fixed Priority
- Programmable Default Master for Each Slave
  - No Default Master
  - Last Accessed Default Master
  - Fixed Default Master
- One Cycle Latency for the First Access of a Burst
- Zero Cycle Latency for Default Master
- One Special Function Register for Each Slave (Not dedicated)

### 19.2 Description

The Bus Matrix implements a multi-layer bus structure, that enables parallel access paths between multiple High Speed Bus (HSB) masters and slaves in a system, thus increasing the overall bandwidth. The Bus Matrix interconnects up to 16 HSB Masters to up to 16 HSB Slaves. The normal latency to connect a master to a slave is one cycle except for the default master of the accessed slave which is connected directly (zero cycle latency). The Bus Matrix provides 16 Special Function Registers (SFR) that allow the Bus Matrix to support application specific features.

### 19.3 Memory Mapping

The Bus Matrix provides one decoder for every HSB Master Interface. The decoder offers each HSB Master several memory mappings. In fact, depending on the product, each memory area may be assigned to several slaves. Booting at the same address while using different HSB slaves (i.e. external RAM, internal ROM or internal Flash, etc.) becomes possible.

The Bus Matrix user interface provides Master Remap Control Register (MRCR) that performs remap action for every master independently.

### 19.4 Special Bus Granting Mechanism

The Bus Matrix provides some speculative bus granting techniques in order to anticipate access requests from some masters. This mechanism reduces latency at first access of a burst or single transfer. This bus granting mechanism sets a different default master for every slave.

At the end of the current access, if no other request is pending, the slave remains connected to its associated default master. A slave can be associated with three kinds of default masters: no default master, last access master and fixed default master.

### 19.4.1 No Default Master

At the end of the current access, if no other request is pending, the slave is disconnected from all masters. No Default Master suits low-power mode.

### 19.4.2 Last Access Master

At the end of the current access, if no other request is pending, the slave remains connected to the last master that performed an access request.

### 19.4.3 Fixed Default Master

At the end of the current access, if no other request is pending, the slave connects to its fixed default master. Unlike last access master, the fixed master does not change unless the user modifies it by a software action (field `FIXED_DEFMSTR` of the related `SCFG`).

To change from one kind of default master to another, the Bus Matrix user interface provides the Slave Configuration Registers, one for each slave, that set a default master for each slave. The Slave Configuration Register contains two fields: `DEFMSTR_TYPE` and `FIXED_DEFMSTR`. The 2-bit `DEFMSTR_TYPE` field selects the default master type (no default, last access master, fixed default master), whereas the 4-bit `FIXED_DEFMSTR` field selects a fixed default master provided that `DEFMSTR_TYPE` is set to fixed default master. Please refer to the Bus Matrix user interface description.

## 19.5 Arbitration

The Bus Matrix provides an arbitration mechanism that reduces latency when conflict cases occur, i.e. when two or more masters try to access the same slave at the same time. One arbiter per HSB slave is provided, thus arbitrating each slave differently.

The Bus Matrix provides the user with the possibility of choosing between 2 arbitration types for each slave:

1. Round-Robin Arbitration (default)
2. Fixed Priority Arbitration

This choice is made via the field `ARBT` of the Slave Configuration Registers (`SCFG`).

Each algorithm may be complemented by selecting a default master configuration for each slave.

When a re-arbitration must be done, specific conditions apply. See [Section 19.5.1 "Arbitration Rules" on page 133](#).

### 19.5.1 Arbitration Rules

Each arbiter has the ability to arbitrate between two or more different master requests. In order to avoid burst breaking and also to provide the maximum throughput for slave interfaces, arbitration may only take place during the following cycles:

1. Idle Cycles: When a slave is not connected to any master or is connected to a master which is not currently accessing it.
2. Single Cycles: When a slave is currently doing a single access.
3. End of Burst Cycles: When the current cycle is the last cycle of a burst transfer. For defined length burst, predicted end of burst matches the size of the transfer but is managed differently for undefined length burst. See [Section "19.5.1.1" on page 134](#).

4. Slot Cycle Limit: When the slot cycle counter has reached the limit value indicating that the current master access is too long and must be broken. See Section “19.5.1.2” on page 134.

#### 19.5.1.1 Undefined Length Burst Arbitration

In order to avoid long slave handling during undefined length bursts (INCR), the Bus Matrix provides specific logic in order to re-arbitrate before the end of the INCR transfer. A predicted end of burst is used as a defined length burst transfer and can be selected from among the following five possibilities:

1. Infinite: No predicted end of burst is generated and therefore INCR burst transfer will never be broken.
2. One beat bursts: Predicted end of burst is generated at each single transfer inside the INCP transfer.
3. Four beat bursts: Predicted end of burst is generated at the end of each four beat boundary inside INCR transfer.
4. Eight beat bursts: Predicted end of burst is generated at the end of each eight beat boundary inside INCR transfer.
5. Sixteen beat bursts: Predicted end of burst is generated at the end of each sixteen beat boundary inside INCR transfer.

This selection can be done through the field ULBT of the Master Configuration Registers (MCFG).

#### 19.5.1.2 Slot Cycle Limit Arbitration

The Bus Matrix contains specific logic to break long accesses, such as very long bursts on a very slow slave (e.g., an external low speed memory). At the beginning of the burst access, a counter is loaded with the value previously written in the SLOT\_CYCLE field of the related Slave Configuration Register (SCFG) and decreased at each clock cycle. When the counter reaches zero, the arbiter has the ability to re-arbitrate at the end of the current byte, half word or word transfer.

### 19.5.2 Round-Robin Arbitration

This algorithm allows the Bus Matrix arbiters to dispatch the requests from different masters to the same slave in a round-robin manner. If two or more master requests arise at the same time, the master with the lowest number is first serviced, then the others are serviced in a round-robin manner.

There are three round-robin algorithms implemented:

- Round-Robin arbitration without default master
- Round-Robin arbitration with last default master
- Round-Robin arbitration with fixed default master

#### 19.5.2.1 Round-Robin Arbitration without Default Master

This is the main algorithm used by Bus Matrix arbiters. It allows the Bus Matrix to dispatch requests from different masters to the same slave in a pure round-robin manner. At the end of the current access, if no other request is pending, the slave is disconnected from all masters. This configuration incurs one latency cycle for the first access of a burst. Arbitration without default master can be used for masters that perform significant bursts.

### 19.5.2.2 *Round-Robin Arbitration with Last Default Master*

This is a biased round-robin algorithm used by Bus Matrix arbiters. It allows the Bus Matrix to remove the one latency cycle for the last master that accessed the slave. In fact, at the end of the current transfer, if no other master request is pending, the slave remains connected to the last master that performed the access. Other non privileged masters still get one latency cycle if they want to access the same slave. This technique can be used for masters that mainly perform single accesses.

### 19.5.2.3 *Round-Robin Arbitration with Fixed Default Master*

This is another biased round-robin algorithm. It allows the Bus Matrix arbiters to remove the one latency cycle for the fixed default master per slave. At the end of the current access, the slave remains connected to its fixed default master. Every request attempted by this fixed default master will not cause any latency whereas other non privileged masters will still get one latency cycle. This technique can be used for masters that mainly perform single accesses.

## 19.5.3 **Fixed Priority Arbitration**

This algorithm allows the Bus Matrix arbiters to dispatch the requests from different masters to the same slave by using the fixed priority defined by the user. If two or more master requests are active at the same time, the master with the highest priority number is serviced first. If two or more master requests with the same priority are active at the same time, the master with the highest number is serviced first.

For each slave, the priority of each master may be defined through the Priority Registers for Slaves (PRAS and PRBS).

## 19.6 **Slave and Master assignation**

The index number assigned to Bus Matrix slaves and masters are described in Memories chapter.

## 19.7 User Interface

**Table 19-1.** Register Mapping

Offset	Register	Name	Access	Reset Value
0x0000	Master Configuration Register 0	MCFG0	Read/Write	0x00000002
0x0004	Master Configuration Register 1	MCFG1	Read/Write	0x00000002
0x0008	Master Configuration Register 2	MCFG2	Read/Write	0x00000002
0x000C	Master Configuration Register 3	MCFG3	Read/Write	0x00000002
0x0010	Master Configuration Register 4	MCFG4	Read/Write	0x00000002
0x0014	Master Configuration Register 5	MCFG5	Read/Write	0x00000002
0x0018	Master Configuration Register 6	MCFG6	Read/Write	0x00000002
0x001C	Master Configuration Register 7	MCFG7	Read/Write	0x00000002
0x0020	Master Configuration Register 8	MCFG8	Read/Write	0x00000002
0x0024	Master Configuration Register 9	MCFG9	Read/Write	0x00000002
0x0028	Master Configuration Register 10	MCFG10	Read/Write	0x00000002
0x002C	Master Configuration Register 11	MCFG11	Read/Write	0x00000002
0x0030	Master Configuration Register 12	MCFG12	Read/Write	0x00000002
0x0034	Master Configuration Register 13	MCFG13	Read/Write	0x00000002
0x0038	Master Configuration Register 14	MCFG14	Read/Write	0x00000002
0x003C	Master Configuration Register 15	MCFG15	Read/Write	0x00000002
0x0040	Slave Configuration Register 0	SCFG0	Read/Write	0x00000010
0x0044	Slave Configuration Register 1	SCFG1	Read/Write	0x00000010
0x0048	Slave Configuration Register 2	SCFG2	Read/Write	0x00000010
0x004C	Slave Configuration Register 3	SCFG3	Read/Write	0x00000010
0x0050	Slave Configuration Register 4	SCFG4	Read/Write	0x00000010
0x0054	Slave Configuration Register 5	SCFG5	Read/Write	0x00000010
0x0058	Slave Configuration Register 6	SCFG6	Read/Write	0x00000010
0x005C	Slave Configuration Register 7	SCFG7	Read/Write	0x00000010
0x0060	Slave Configuration Register 8	SCFG8	Read/Write	0x00000010
0x0064	Slave Configuration Register 9	SCFG9	Read/Write	0x00000010
0x0068	Slave Configuration Register 10	SCFG10	Read/Write	0x00000010
0x006C	Slave Configuration Register 11	SCFG11	Read/Write	0x00000010
0x0070	Slave Configuration Register 12	SCFG12	Read/Write	0x00000010
0x0074	Slave Configuration Register 13	SCFG13	Read/Write	0x00000010
0x0078	Slave Configuration Register 14	SCFG14	Read/Write	0x00000010
0x007C	Slave Configuration Register 15	SCFG15	Read/Write	0x00000010
0x0080	Priority Register A for Slave 0	PRAS0	Read/Write	0x00000000
0x0084	Priority Register B for Slave 0	PRBS0	Read/Write	0x00000000
0x0088	Priority Register A for Slave 1	PRAS1	Read/Write	0x00000000





**Table 19-1. Register Mapping (Continued)**

Offset	Register	Name	Access	Reset Value
0x008C	Priority Register B for Slave 1	PRBS1	Read/Write	0x00000000
0x0090	Priority Register A for Slave 2	PRAS2	Read/Write	0x00000000
0x0094	Priority Register B for Slave 2	PRBS2	Read/Write	0x00000000
0x0098	Priority Register A for Slave 3	PRAS3	Read/Write	0x00000000
0x009C	Priority Register B for Slave 3	PRBS3	Read/Write	0x00000000
0x00A0	Priority Register A for Slave 4	PRAS4	Read/Write	0x00000000
0x00A4	Priority Register B for Slave 4	PRBS4	Read/Write	0x00000000
0x00A8	Priority Register A for Slave 5	PRAS5	Read/Write	0x00000000
0x00AC	Priority Register B for Slave 5	PRBS5	Read/Write	0x00000000
0x00B0	Priority Register A for Slave 6	PRAS6	Read/Write	0x00000000
0x00B4	Priority Register B for Slave 6	PRBS6	Read/Write	0x00000000
0x00B8	Priority Register A for Slave 7	PRAS7	Read/Write	0x00000000
0x00BC	Priority Register B for Slave 7	PRBS7	Read/Write	0x00000000
0x00C0	Priority Register A for Slave 8	PRAS8	Read/Write	0x00000000
0x00C4	Priority Register B for Slave 8	PRBS8	Read/Write	0x00000000
0x00C8	Priority Register A for Slave 9	PRAS9	Read/Write	0x00000000
0x00CC	Priority Register B for Slave 9	PRBS9	Read/Write	0x00000000
0x00D0	Priority Register A for Slave 10	PRAS10	Read/Write	0x00000000
0x00D4	Priority Register B for Slave 10	PRBS10	Read/Write	0x00000000
0x00D8	Priority Register A for Slave 11	PRAS11	Read/Write	0x00000000
0x00DC	Priority Register B for Slave 11	PRBS11	Read/Write	0x00000000
0x00E0	Priority Register A for Slave 12	PRAS12	Read/Write	0x00000000
0x00E4	Priority Register B for Slave 12	PRBS12	Read/Write	0x00000000
0x00E8	Priority Register A for Slave 13	PRAS13	Read/Write	0x00000000
0x00EC	Priority Register B for Slave 13	PRBS13	Read/Write	0x00000000
0x00F0	Priority Register A for Slave 14	PRAS14	Read/Write	0x00000000
0x00F4	Priority Register B for Slave 14	PRBS14	Read/Write	0x00000000
0x00F8	Priority Register A for Slave 15	PRAS15	Read/Write	0x00000000
0x00FC	Priority Register B for Slave 15	PRBS15	Read/Write	0x00000000
0x0100	Master Remap Control Register	MRCR	Read/Write	0x00000000
0x0104 - 0x010C	Reserved	-	-	-
0x0110	Special Function Register 0	SFR0	Read/Write	-
0x0114	Special Function Register 1	SFR1	Read/Write	-
0x0118	Special Function Register 2	SFR2	Read/Write	-
0x011C	Special Function Register 3	SFR3	Read/Write	-
0x0120	Special Function Register 4	SFR4	Read/Write	-

**Table 19-1.** Register Mapping (Continued)

Offset	Register	Name	Access	Reset Value
0x0124	Special Function Register 5	SFR5	Read/Write	–
0x0128	Special Function Register 6	SFR6	Read/Write	–
0x012C	Special Function Register 7	SFR7	Read/Write	–
0x0130	Special Function Register 8	SFR8	Read/Write	–
0x0134	Special Function Register 9	SFR9	Read/Write	–
0x0138	Special Function Register 10	SFR10	Read/Write	–
0x013C	Special Function Register 11	SFR11	Read/Write	–
0x0140	Special Function Register 12	SFR12	Read/Write	–
0x0144	Special Function Register 13	SFR13	Read/Write	–
0x0148	Special Function Register 14	SFR14	Read/Write	–
0x014C	Special Function Register 15	SFR15	Read/Write	–
0x0150 - 0x01F8	Reserved	–	–	–

## 19.7.1 Bus Matrix Master Configuration Registers

**Register Name:** MCFG0...MCFG15

**Access Type:** Read/Write

31	30	29	28	27	26	25	24
–	–	–	–	–	–	–	–
23	22	21	20	19	18	17	16
–	–	–	–	–	–	–	–
15	14	13	12	11	10	9	8
–	–	–	–	–	–	–	–
7	6	5	4	3	2	1	0
–	–	–	–	–	ULBT		

- **ULBT: Undefined Length Burst Type**

0: Infinite Length Burst

No predicted end of burst is generated and therefore INCR bursts coming from this master cannot be broken.

1: Single Access

The undefined length burst is treated as a succession of single accesses, allowing re-arbitration at each beat of the INCR burst.

2: Four Beat Burst

The undefined length burst is split into a four-beat burst, allowing re-arbitration at each four-beat burst end.

3: Eight Beat Burst

The undefined length burst is split into an eight-beat burst, allowing re-arbitration at each eight-beat burst end.

4: Sixteen Beat Burst

The undefined length burst is split into a sixteen-beat burst, allowing re-arbitration at each sixteen-beat burst end.

## 19.7.2 Bus Matrix Slave Configuration Registers

**Register Name:** SCFG0...SCFG15

**Access Type:** Read/Write

31	30	29	28	27	26	25	24
–	–	–	–	–	–	–	ARBT
23	22	21	20	19	18	17	16
–	–	FIXED_DEFMSTR				DEFMSTR_TYPE	
15	14	13	12	11	10	9	8
–	–	–	–	–	–	–	–
7	6	5	4	3	2	1	0
SLOT_CYCLE							

- **SLOT\_CYCLE: Maximum Number of Allowed Cycles for a Burst**

When the SLOT\_CYCLE limit is reached for a burst, it may be broken by another master trying to access this slave.

This limit has been placed to avoid locking a very slow slave when very long bursts are used.

This limit must not be very small. Unreasonably small values break every burst and the Bus Matrix arbitrates without performing any data transfer. 16 cycles is a reasonable value for SLOT\_CYCLE.

- **DEFMSTR\_TYPE: Default Master Type**

0: No Default Master

At the end of the current slave access, if no other master request is pending, the slave is disconnected from all masters.

This results in a one cycle latency for the first access of a burst transfer or for a single access.

1: Last Default Master

At the end of the current slave access, if no other master request is pending, the slave stays connected to the last master having accessed it.

This results in not having one cycle latency when the last master tries to access the slave again.

2: Fixed Default Master

At the end of the current slave access, if no other master request is pending, the slave connects to the fixed master the number that has been written in the FIXED\_DEFMSTR field.

This results in not having one cycle latency when the fixed master tries to access the slave again.

- **FIXED\_DEFMSTR: Fixed Default Master**

This is the number of the Default Master for this slave. Only used if DEFMSTR\_TYPE is 2. Specifying the number of a master which is not connected to the selected slave is equivalent to setting DEFMSTR\_TYPE to 0.

- **ARBT: Arbitration Type**

0: Round-Robin Arbitration

1: Fixed Priority Arbitration

## 19.7.3 Bus Matrix Priority Registers A For Slaves

**Register Name:** PRAS0...PRAS15

**Access Type:** Read/Write

31	30	29	28	27	26	25	24
M7PR				M6PR			
23	22	21	20	19	18	17	16
M5PR				M4PR			
15	14	13	12	11	10	9	8
M3PR				M2PR			
7	6	5	4	3	2	1	0
M1PR				M0PR			

- **MxPR: Master x Priority**

Fixed priority of Master x for accessing the selected slave. The higher the number, the higher the priority.

19.7.4 Bus Matrix Priority Registers B For Slaves

Register Name: PRBS0...PRBS15

Access Type: Read/Write

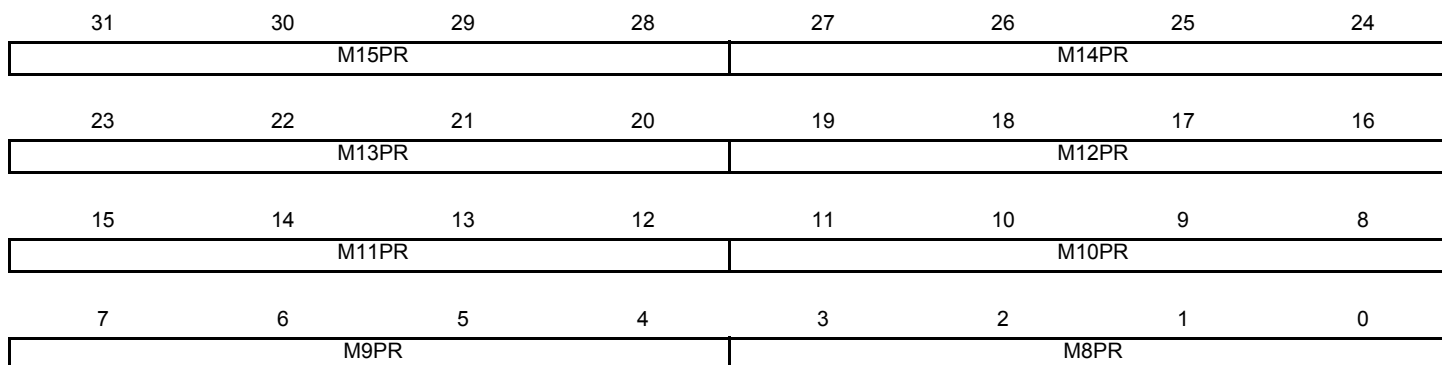

- **MxPR: Master x Priority**

Fixed priority of Master x for accessing the selected slave. The higher the number, the higher the priority.

## 19.7.5 Bus Matrix Master Remap Control Register

**Register Name:** MR CR

**Access Type:** Read/Write

**Reset:** 0x0000\_0000

31	30	29	28	27	26	25	24
-	-	-	-	-	-	-	-
23	22	21	20	19	18	17	16
-	-	-	-	-	-	-	-
15	14	13	12	11	10	9	8
RCB15	RCB14	RCB13	RCB12	RCB11	RCB10	RCB9	RCB8
7	6	5	4	3	2	1	0
RCB7	RCB6	RCB5	RCB4	RCB3	RCB2	RCB1	RCB0

- **RCB: Remap Command Bit for Master x**

0: Disable remapped address decoding for the selected Master

1: Enable remapped address decoding for the selected Master

## 19.7.6 Bus Matrix Special Function Registers

**Register Name:** SFR0...SFR15

**Access Type:** Read/Write

**Reset:**

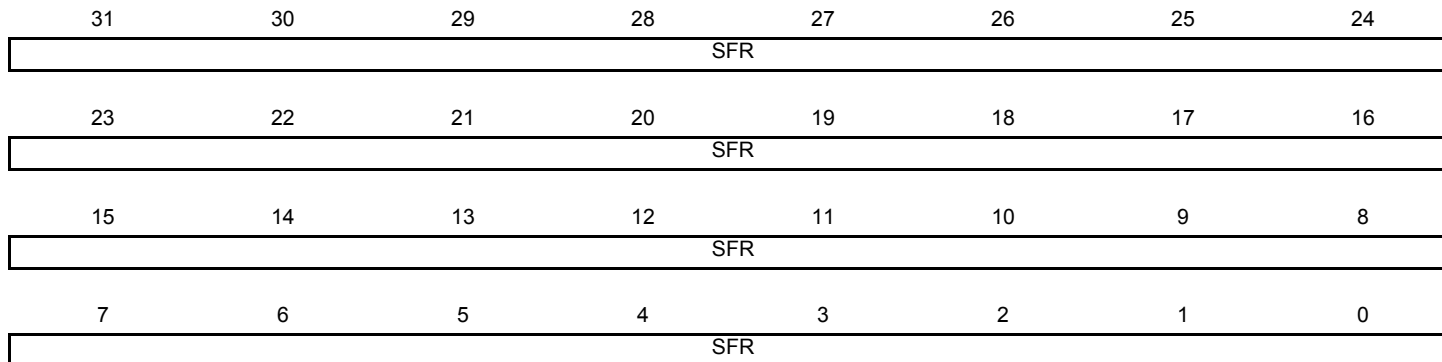

- **SFR: Special Function Register Fields**

The bitfields of these registers are described in the Peripherals chapter.



## 20. External Bus Interface (EBI)

Rev: 1.0.0.1

### 20.1 Features

- Present only on AT32UC3A0512 and AT32UC3A0256
- Optimized for Application Memory Space support
- Integrates Two External Memory Controllers:
  - Static Memory Controller
  - SDRAM Controller
- Optimized External Bus:
  - 16-bit Data Bus
  - 24-bit Address Bus, Up to 16-Mbytes Addressable
  - Optimized pin multiplexing to reduce latencies on External Memories
- 4 SRAM Chip Selects, 1 SDRAM Chip Selects:
  - Static Memory Controller on NCS0
  - SDRAM Controller or Static Memory Controller on NCS1
  - Static Memory Controller on NCS2
  - Static Memory Controller on NCS3

### 20.2 Description

The External Bus Interface (EBI) is designed to ensure the successful data transfer between several external devices and the AT32UC3A device. The Static Memory and SDRAM Controllers are all featured external Memory Controllers on the EBI. These external Memory Controllers are capable of handling several types of external memory and peripheral devices, such as SRAM, PROM, EPROM, EEPROM, Flash, and SDRAM.

The EBI handles data transfers with up to five external devices, each assigned to five address spaces defined by the embedded Memory Controller. Data transfers are performed through a 16-bit data bus, an address bus of up to 24 bits, up to four chip select lines (NCS[3:0]) and several control pins that are generally multiplexed between the different external Memory Controllers.

## 20.3 Block Diagram

### 20.3.1 External Bus Interface

Figure 20-1 shows the organization of the External Bus Interface.

Figure 20-1. Organization of the External Bus Interface

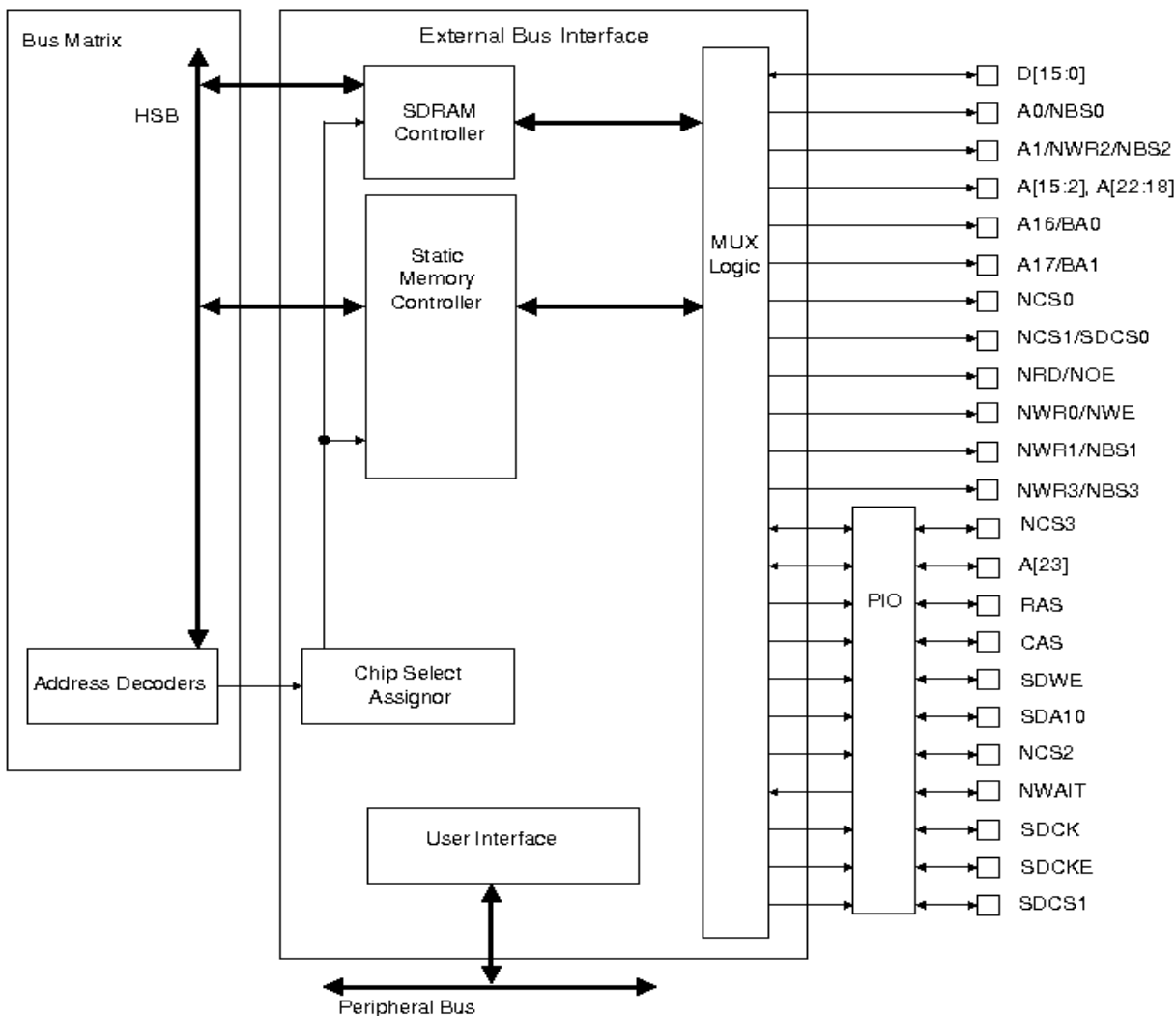

## 20.4 I/O Lines Description

**Table 20-1.** EBI I/O Lines Description

Name	Function	Type	Active Level
<b>EBI</b>			
D0 - D15	Data Bus	I/O	
A0 - A23	Address Bus	Output	
NWAIT	External Wait Signal	Input	Low
<b>SMC</b>			
NCS0 - NCS3	Chip Select Lines	Output	Low
NWR0 - NWR3	Write Signals	Output	Low
NOE	Output Enable	Output	Low
NRD	Read Signal	Output	Low
NWE	Write Enable	Output	Low
NBS0 - NBS3	Byte Mask Signals	Output	Low
<b>SDRAM Controller</b>			
SDCK	SDRAM Clock	Output	
SDCKE	SDRAM Clock Enable	Output	High
BA0 - BA1	Bank Select	Output	
SDWE	SDRAM Write Enable	Output	Low
RAS - CAS	Row and Column Signal	Output	Low
NWR0 - NWR3	Write Signals	Output	Low
NBS0 - NBS3	Byte Mask Signals	Output	Low
SDA10	SDRAM Address 10 Line	Output	

Depending on the Memory Controller in use, all signals are not connected directly through the Mux Logic.

[Table 20-2 on page 147](#) details the connections between the two Memory Controllers and the EBI pins.

**Table 20-2.** EBI Pins and Memory Controllers I/O Lines Connections

EBI Pins	SDRAMC I/O Lines	SMC I/O Lines
NWR1/NBS1	NBS1	NWR1/NUB
A0/NBS0	Not Supported	SMC_A0/NLB
A1/NBS2/NWR2	Not Supported	SMC_A1
A[11:2]	SDRAMC_A[9:0]	SMC_A[11:2]
SDA10	SDRAMC_A10	Not Supported
A12	Not Supported	SMC_A12
A[14:13]	SDRAMC_A[12:11]	SMC_A[14:13]

**Table 20-2.** EBI Pins and Memory Controllers I/O Lines Connections

EBI Pins	SDRAMC I/O Lines	SMC I/O Lines
A[22:15]	Not Supported	SMC_A[22:15]
A[23]	Not Supported	SMC_A[23]
D[15:0]	D[15:0]	D[15:0]

## 20.5 Application Example

### 20.5.1 Hardware Interface

Table 20-3 on page 148 details the connections to be applied between the EBI pins and the external devices for each Memory Controller.

**Table 20-3.** EBI Pins and External Static Devices Connections

Signals	Pins of the Interfaced Device		
	8-bit Static Device	2 x 8-bit Static Devices	16-bit Static Device
<b>Controller</b>	<b>SMC</b>		
D0 - D7	D0 - D7	D0 - D7	D0 - D7
D8 - D15	–	D8 - D15	D8 - D15
A0/NBS0	A0	–	NLB
A1/NWR2/NBS2	A1	A0	A0
A2 - A22	A[2:22]	A[1:21]	A[1:21]
A23	A[23]	A[22]	A[22]
NCS0	CS	CS	CS
NCS1/SDCS0	CS	CS	CS
NCS2	CS	CS	CS
NCS3	CS	CS	CS
NRD/NOE	OE	OE	OE
NWR0/NWE	WE	WE <sup>(1)</sup>	WE
NWR1/NBS1	–	WE <sup>(1)</sup>	NUB
NWR3/NBS3	–	–	–

- Notes:
1. NWR1 enables upper byte writes. NWR0 enables lower byte writes.
  2. NWRx enables corresponding byte x writes. (x = 0,1,2 or 3)
  3. NBS0 and NBS1 enable respectively lower and upper bytes of the lower 16-bit word.
  4. NBS2 and NBS3 enable respectively lower and upper bytes of the upper 16-bit word.
  5. BEx: Byte x Enable (x = 0,1,2 or 3)

**Table 20-4.** EBI Pins and External SDRAM Devices Connections

Signals	Pins of the Interfaced Device
	SDRAM
Controller	SDRAMC
D0 - D15	D0 - D15
A0/NBS0	DQM0
A1/NWR2/NBS2	DQM2
A2 - A10	A[0:8]
A11	A9
SDA10	A10
A12	–
A13 - A14	A[11:12]
A15	–
A16/BA0	BA0
A17/BA1	BA1
A18 - A23	–
NCS0	–
NCS1/SDCS0	CS[0]
NCS2	–
NCS2	–
NCS3	–
NRD/NOE	–
NWR0/NWE	–
NWR1/NBS1	DQM1
NWR3/NBS3	DQM3
SDCK	CLK
SDCKE	CKE
RAS	RAS
CAS	CAS
SDWE	WE
NWAIT	–

## 20.5.2 Connection Examples

Figure 20-2 shows an example of connections between the EBI and external devices.

**Figure 20-2.** EBI Connections to Memory Devices

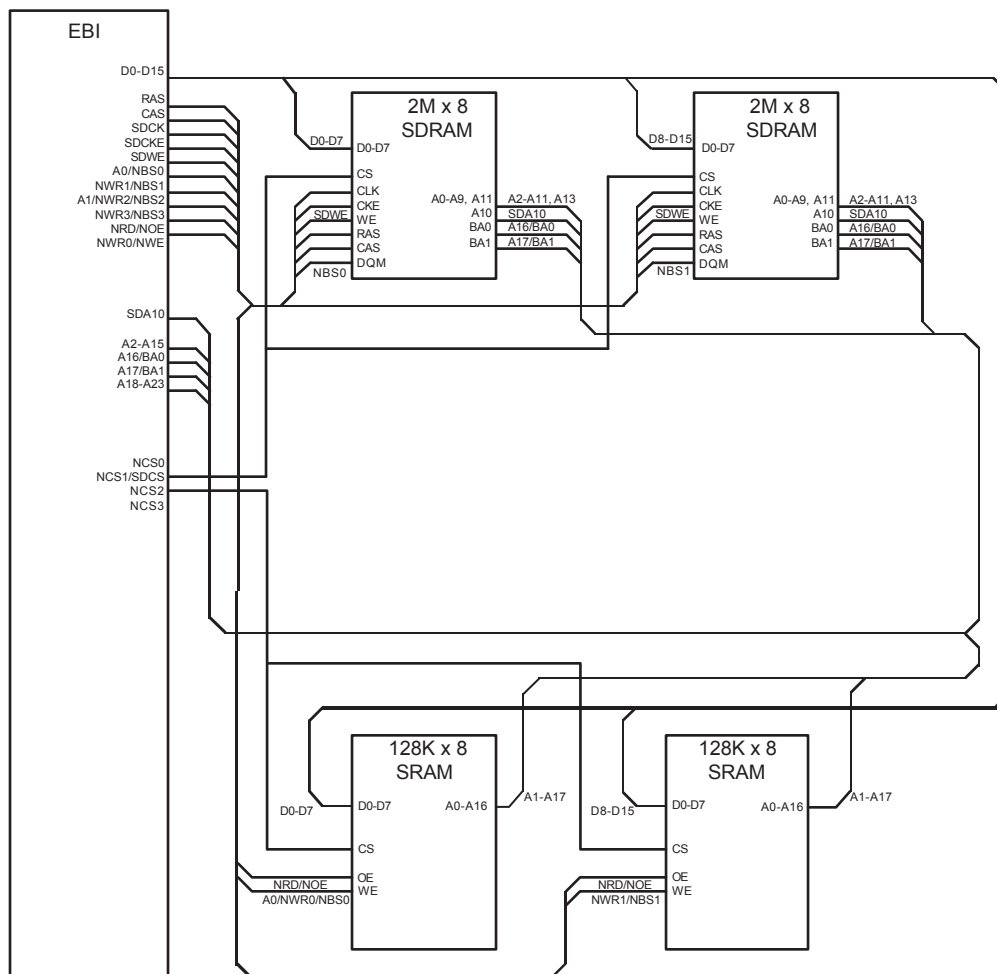

## 20.6 Product Dependencies

### 20.6.1 I/O Lines

The pins used for interfacing the External Bus Interface may be multiplexed with the GPIO lines. The programmer must first program the GPIO controller to assign the External Bus Interface pins to their peripheral function. If I/O lines of the External Bus Interface are not used by the application, they can be used for other purposes by the GPIO Controller.

### 20.6.2 Power Management

The EBI HSB clock and SDRAMC, SMC and ECC PB clocks are generated by the Power Manager. Before using the EBI, the programmer must ensure that these clocks are enabled in the Power Manager.

To prevent bus errors EBI operation must be terminated before entering sleep mode

### 20.6.3 Interrupt

The EBI interface has an interrupt line connected to the Interrupt Controller. Handling the EBI interrupt requires programming the interrupt controller before configuring the EBI.

## 20.7 Functional Description

The EBI transfers data between the internal HSB Bus (handled by the HMatrix) and the external memories or peripheral devices. It controls the waveforms and the parameters of the external address, data and control busses and is composed of the following elements:

- The Static Memory Controller (SMC)
- The SDRAM Controller (SDRAMC)
- A chip select assignment feature that assigns an HSB address space to the external devices
- A multiplex controller circuit that shares the pins between the different Memory Controllers

### 20.7.1 Bus Multiplexing

The EBI offers a complete set of control signals that share the 16-bit data lines, the address lines of up to 24 bits and the control signals through a multiplex logic operating in function of the memory area requests.

Multiplexing is specifically organized in order to guarantee the maintenance of the address and output control lines at a stable state while no external access is being performed. Multiplexing is also designed to respect the data float times defined in the Memory Controllers. Furthermore, refresh cycles of the SDRAM are executed independently by the SDRAM Controller without delaying the other external Memory Controller accesses.

### 20.7.2 Pull-up Control

A specific HMATRIX\_SFR register in the Matrix User Interface permit enabling of on-chip pull-up resistors on the data bus lines not multiplexed with the GPIO Controller lines. For details on this register, refer to the Peripherals Section. The pull-up resistors are enabled after reset. Setting the EBI\_DBPUC bit disables the pull-up resistors on lines not muxed with GPIO. Enabling the pull-up resistor on lines multiplexed with GPIO lines can be performed by programming the appropriate GPIO controller.

**20.7.3 Static Memory Controller**

For information on the Static Memory Controller, refer to the Static Memory Controller Section.

**20.7.4 SDRAM Controller**

For information on the SDRAM Controller, refer to the SDRAM Section.



## 21. Peripheral DMA Controller (PDCA)

rev: 1.0.0.0

### 21.1 Features

- Generates Transfers to/from Peripherals such as USART, SSC and SPI
- Two address pointers/counters per channel allowing double buffering

### 21.2 Overview

The Peripheral DMA controller (PDCA) transfers data between on-chip peripheral modules such as USART, SPI, SSC and on- and off-chip memories. Using the PDCA avoids CPU intervention for data transfers, improving the performance of the microcontroller. The PDCA can transfer data from memory to a peripheral or from a peripheral to memory.

The PDCA consists of a number of DMA channels. Each channel has:

- A 32-bit memory pointer
- A 16-bit transfer counter
- A 32-bit memory pointer reload value
- A 16-bit transfer counter reload value

The PDCA communicates with the peripheral modules over a number of handshake interfaces. The peripheral signals to the PDCA when it is ready to receive or transmit data. The PDCA acknowledges the request when the transmission has started.

The number of handshake-interfaces may be higher than the number of DMA channels. If this is the case, the DMA channel must be programmed to use the desired interface.

When a transmit buffer is empty or a receive buffer is full, an interrupt request can be signalled.

## 21.3 Block Diagram

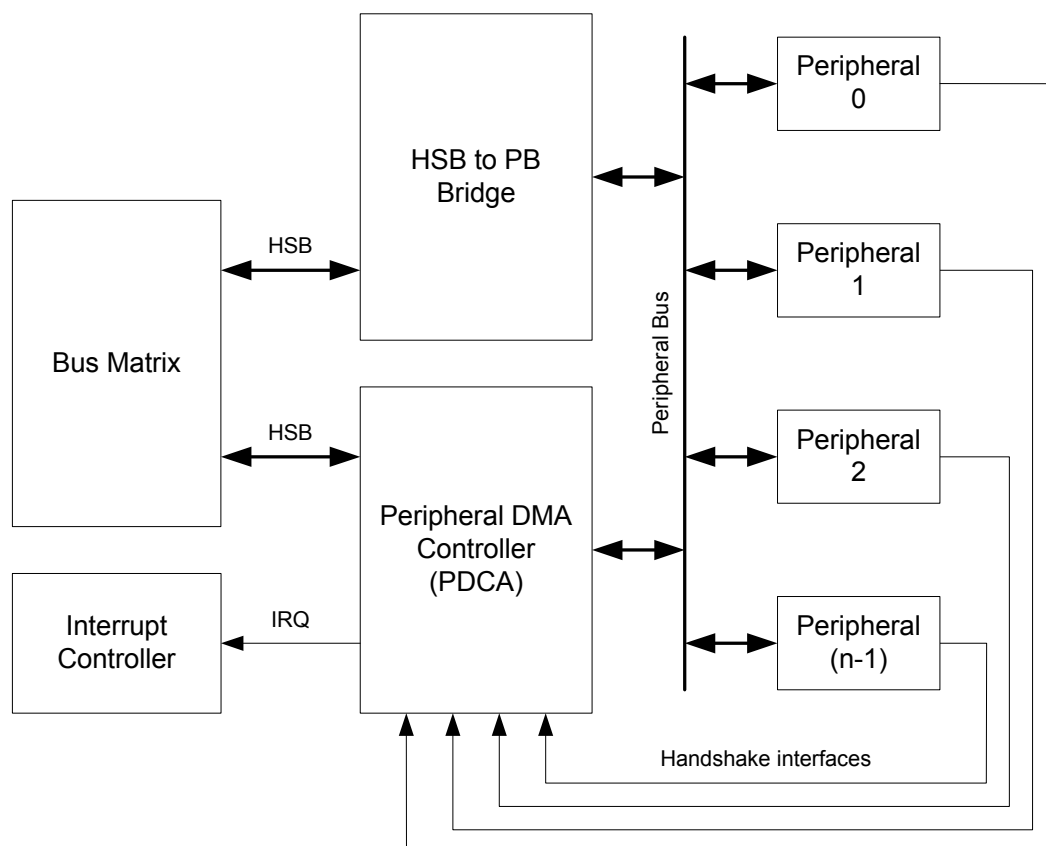

## 21.4 Functional Description

### 21.4.1 Configuration

Each channel in the PDCA has a set of configuration registers. Among these are the Memory Address Register (MAR), the Peripheral Select Register (PSR) and the Transfer Counter Register (TCR). The 32-bit Memory Address Register must be programmed with the start address of the memory buffer. The register will be automatically updated after each transfer to point to the next location in memory. The Peripheral Select Register must be programmed to select the desired peripheral/handshake interface. The Transfer Counter Register determines the number of data items to be transferred. The counter will be decreased by one for each data item that has been transferred.

Both the Memory Address Register and the Transfer Counter Register can be read at any time to check the progress of the transfer.

Each channel has also reload registers for the Memory Address Register and the Transfer Counter Register. When the TCR reaches zero, the values in the reload registers are loaded into MAR and TCR. In this way, the PDCA can operate on two buffers for each channel.

### 21.4.2 Memory Pointer

Each channel has a 32-bit Memory Pointer Register (MAR). This register holds the memory address for the next transfer to be performed. The register is automatically updated after each

transfer. The address will be increased by either 1, 2 or 4 depending on the size of the DMA transfer (Byte, Half-Word or Word). The Memory Address Register can be read at any time during transfer.

#### 21.4.3 Transfer Counter

Each channel has a 16-bit Transfer Counter Register (TCR). This register must be programmed with the number of transferred to be performed. TCR should contain the number of data items to be transferred independently of the transfer size. The Transfer Counter Register can be read at any time during transfer to see the number of remaining transfers.

#### 21.4.4 Reload Registers

Both the Memory Address Register and the Transfer Counter Register have a reload register, respectively Memory Address Reload Register (MARR) and Transfer Counter Reload Register (TCRR). These registers provide the possibility for the PDCA to work on two memory buffers for each channel. When one buffer has completed, MAR and TCR will be reloaded with the values in MARR and TCRR. The reload logic is always enabled and will trigger if the TCR reaches zero while TCRR holds a non-zero value.

#### 21.4.5 Peripheral Selection

The Peripheral Select Register decides which peripheral should be connected to the PDCA channel. Configuring PSR will both select the direction of the transfer (memory to peripheral or peripheral to memory), which handshake interface to use, and the address of the peripheral holding register.

#### 21.4.6 Transfer Size

The transfer size can be set individually for each channel to be either Byte, Half-Word or Word (8-bit, 16-bit or 32-bit respectively). Transfer size is set by programming the SIZE bit-field in the Mode Register (MR).

#### 21.4.7 Enabling and Disabling

Each DMA channel is enabled by writing '1' to the Transfer Enable bit (TEN) in the Control Register (CR) and disabled by writing '1' to the Transfer Disable bit (TDIS). The current status can be read from the Status Register (SR).

#### 21.4.8 Interrupts

Interrupts can be enabled by writing to the Interrupt Enable Register (IER) and disabled by writing to Interrupt Disable Register (IDR). The Interrupt Mask Register (IMR) can be read to see whether an interrupt is enabled or not. The current status of an interrupt source can be read through the Interrupt Status Register (ISR).

The PDCA has three interrupt sources:

- Reload Counter Zero - The Transfer Counter Reload Register is zero.
- Transfer Finished - Both the Transfer Counter Register and Transfer Counter Reload Register are zero.
- Transfer Error - An error has occurred in accessing memory.

## 21.4.9 Priority

If more than one PDCA channel is requesting transfer at a given time, the PDCA channels are prioritized by their channel number. Channels with lower numbers have priority over channels with higher numbers, giving channel 0 the highest priority.

## 21.4.10 Error Handling

If the memory address is set to point to an invalid location in memory, an error will occur when the PDCA tries to perform a transfer. When an error occurs, the Transfer Error flag (TERR) in the Interrupt Status Register will be set and the DMA channel that caused the error will be stopped. In order to restart the channel, the user must program the Memory Address Register to a valid address and then write the Error Clear bit (ECLR) in the Control Register (CR) to '1'. An interrupt can optionally be triggered on errors by writing the TERR-bit in the Interrupt Enable Register (IER) to '1'.

## 21.5 User Interface

### 21.5.1 Memory Map Overview

**Table 21-1.** Register Map Overview

Address Range	Contents
0x0000 - 0x003F	DMA channel 0 configuration registers
0x0040 - 0x007F	DMA channel 1 configuration registers
0x0080 - 0x00BF	DMA channel 2 configuration registers
0x00C0 - 0x00FF	DMA channel 3 configuration registers
0x0100 - 0x013F	DMA channel 4 configuration registers
-	-
-	DMA channel n-1 configuration registers

Note: The number of channels is implementation specific. See part documentation for details.

### 21.5.2 Channel Memory Map

Offset	Register	Register Name	Access	Reset
0x00	Memory Address Register	MAR	Read/Write	0x00000000
0x04	Peripheral Select Register	PSR	Read/Write	*
0x08	Transfer Counter Register	TCR	Read/Write	0x00000000
0x0C	Memory Address Reload Register	MARR	Read/Write	0x00000000
0x10	Transfer Counter Reload Register	TCRR	Read/Write	0x00000000
0x14	Control Register	CR	Write-only	-
0x18	Mode Register	MR	Read/Write	0x00000000
0x1C	Status Register	SR	Read-only	0x00000000
0x20	Interrupt Enable Register	IER	Write-only	-

Offset	Register	Register Name	Access	Reset
0x24	Interrupt Disable Register	IDR	Write-only	-
0x28	Interrupt Mask Register	IMR	Read-only	0x00000000
0x2C	Interrupt Status Register	ISR	Read-only	0x00000000

## 21.5.3 PDCA Memory Address Register

**Name:** MAR

**Access Type:** Read/Write

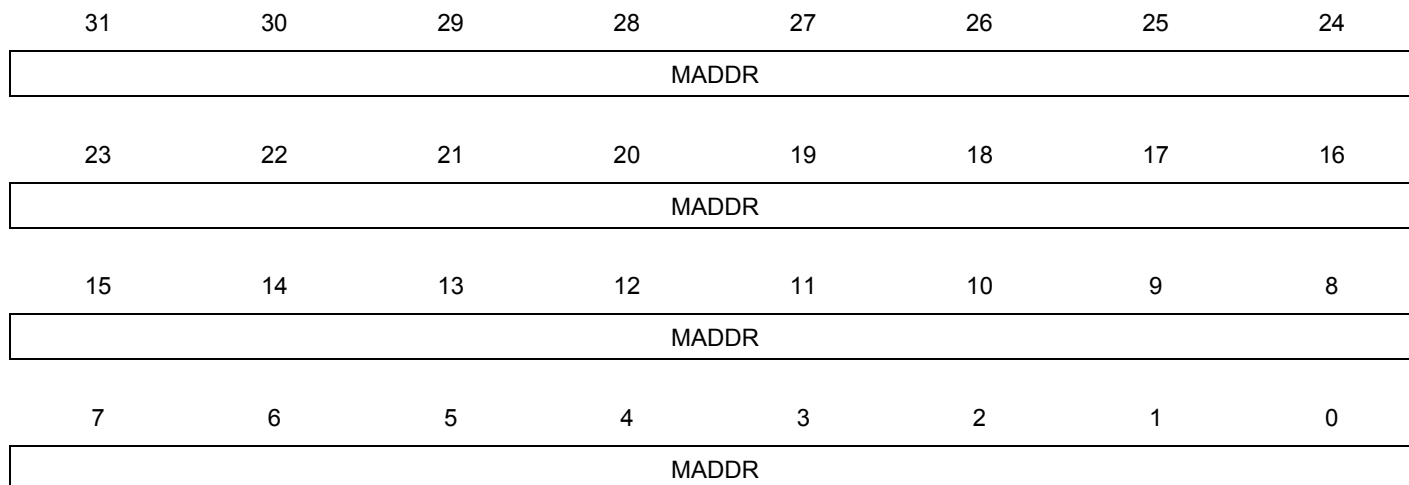

- **MADDR: Memory Address**

Address of memory buffer. MADDR should be programmed to point to the start of the memory buffer when configuring the PDCA. During transfer, MADDR will point to the next memory location to be read/written.

## 21.5.4 PDCA Peripheral Select Register

**Name:** PSR

**Access Type:** Read/Write

31	30	29	28	27	26	25	24
-	-	-	-	-	-	-	-
23	22	21	20	19	18	17	16
-	-	-	-	-	-	-	-
15	14	13	12	11	10	9	8
-	-	-	-	-	-	-	-
7	6	5	4	3	2	1	0
PID							

- **PID: Peripheral Identifier**

The Peripheral Identifier selects which peripheral should be connected to the DMA channel. Programming PID will select both which handshake interface to use, the direction of the transfer and also the address of the Receive/Transfer Holding Register for the peripheral. The PID values for the different peripheral modules are implementation specific. See the part specific documentation for details.

The width of the PID bitfield is implementation specific and dependent on the number of peripheral modules in the microcontroller.

## 21.5.5 PDCA Transfer Counter Register

**Name:** TCR

**Access Type:** Read/Write

31	30	29	28	27	26	25	24
-	-	-	-	-	-	-	-
23	22	21	20	19	18	17	16
-	-	-	-	-	-	-	-
15	14	13	12	11	10	9	8
TCV							
7	6	5	4	3	2	1	0
TCV							

- **TCV: Transfer Counter Value**

Number of data items to be transferred by PDCA. TCV must be programmed with the total number of transfers to be made. During transfer, TCV contains the number of remaining transfers to be done.



## 21.5.6 PDCA Memory Address Reload Register

**Name:** MARR

**Access Type:** Read/Write

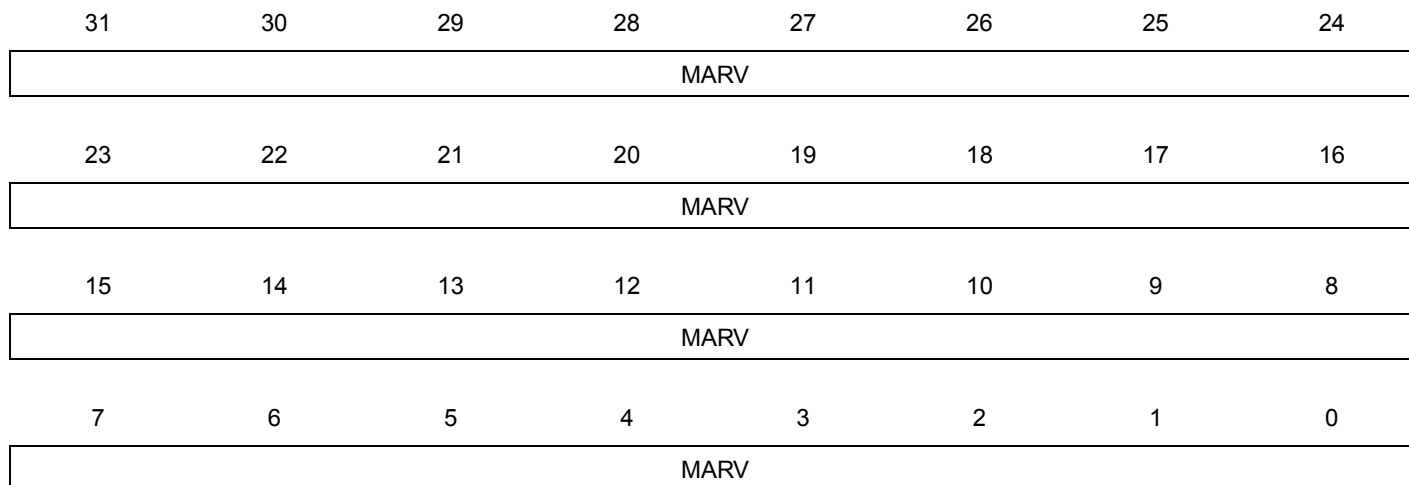

- **MARV: Memory Address Reload Value**

Reload Value for the Memory Address Register (MAR). This value will be loaded into MAR when TCR reaches zero if the TCRR has a non-zero value.

## 21.5.7 PDCA Transfer Counter Reload Register

**Name:** TCRR

**Access Type:** Read/Write

31	30	29	28	27	26	25	24
-	-	-	-	-	-	-	-
23	22	21	20	19	18	17	16
-	-	-	-	-	-	-	-
15	14	13	12	11	10	9	8
TCRV							
7	6	5	4	3	2	1	0
TCRV							

- **TCRV: Transfer Counter Reload Value**

Reload value for the Transfer Counter Register (TCR). When TCR reaches zero, it will be reloaded with TCRV if TCRV has a positive value. If TCRV is zero, no more transfers will be performed for the channel. When TCR is reloaded, the Transfer Counter Reload Register is cleared.

## 21.5.8 PDCA Control Register

**Name:** CR

**Access Type:** Write-only

31	30	29	28	27	26	25	24
-	-	-	-	-	-	-	-
23	22	21	20	19	18	17	16
-	-	-	-	-	-	-	-
15	14	13	12	11	10	9	8
-	-	-	-	-	-	-	ECLR
7	6	5	4	3	2	1	0
-	-	-	-	-	-	TDIS	TEN

- **ECLR: Error Clear**

0 = No Effect.

1 = Clear Transfer Error (TERR) flag in the Status Register (SR). Clearing the Transfer Error flag will allow the channel to transmit data. The memory address must first be set to point to a valid location.

- **TEN: Transfer Enable**

0 = No Effect.

1 = Enable transfer for DMA channel.

- **TDIS: Transfer Disable**

0 = No Effect.

1 = Disable transfer for DMA channel.

## 21.5.9 PDCA Mode Register

**Name:** MR

**Access Type:** Read/Write

31	30	29	28	27	26	25	24
-	-	-	-	-	-	-	-
23	22	21	20	19	18	17	16
-	-	-	-	-	-	-	-
15	14	13	12	11	10	9	8
-	-	-	-	-	-	-	-
7	6	5	4	3	2	1	0
-	-	-	-	-	-	SIZE	

• **SIZE:** Size of transfer

SIZE		Size of Transfer
0	0	Byte
0	1	Half-Word
1	0	Word
1	1	Reserved

## 21.5.10 PDCA Status Register

**Name:** SR

**Access Type:** Read

31	30	29	28	27	26	25	24
-	-	-	-	-	-	-	-
23	22	21	20	19	18	17	16
-	-	-	-	-	-	-	-
15	14	13	12	11	10	9	8
-	-	-	-	-	-	-	-
7	6	5	4	3	2	1	0
-	-	-	-	-	-	-	TEN

- **TEN: Transfer Enabled**

0 = Transfer is disabled for the DMA channel

1 = Transfer is enabled for the DMA channel.

## 21.5.11 PDCA Interrupt Enable Register

**Name:** IER

**Access Type:** Write-only

31	30	29	28	27	26	25	24
-	-	-	-	-	-	-	-
23	22	21	20	19	18	17	16
-	-	-	-	-	-	-	-
15	14	13	12	11	10	9	8
-	-	-	-	-	-	-	-
7	6	5	4	3	2	1	0
-	-	-	-	-	TERR	TRC	RCZ

- **TERR: Transfer Error**

0 = No effect.

1 = Enable Transfer Error interrupt.

- **TRC: Transfer Complete**

0 = No effect.

1 = Enable Transfer Complete interrupt.

- **RCZ: Reload Counter Zero**

0 = No effect.

1 = Enable Reload Counter Zero interrupt.

## 21.5.12 PDCA Interrupt Disable Register

**Name:** IDR

**Access Type:** Write-only

31	30	29	28	27	26	25	24
-	-	-	-	-	-	-	-
23	22	21	20	19	18	17	16
-	-	-	-	-	-	-	-
15	14	13	12	11	10	9	8
-	-	-	-	-	-	-	-
7	6	5	4	3	2	1	0
-	-	-	-	-	TERR	TRC	RCZ

- **TERR: Transfer Error**

0 = No effect.

1 = Disable Transfer Error interrupt.

- **TRC: Transfer Complete**

0 = No effect.

1 = Disable Transfer Complete interrupt.

- **RCZ: Reload Counter Zero**

0 = No effect.

1 = Disable Reload Counter Zero interrupt.

## 21.5.13 PDCA Interrupt Mask Register

**Name:** IMR

**Access Type:** Read-only

31	30	29	28	27	26	25	24
-	-	-	-	-	-	-	-
23	22	21	20	19	18	17	16
-	-	-	-	-	-	-	-
15	14	13	12	11	10	9	8
-	-	-	-	-	-	-	-
7	6	5	4	3	2	1	0
-	-	-	-	-	TERR	TRC	RCZ

- **TERR: Transfer Error**

0 = Transfer Error interrupt is disabled.

1 = Transfer Error interrupt is enabled.

- **TRC: Transfer Complete**

0 = Transfer Complete interrupt is disabled.

1 = Transfer Complete interrupt is enabled.

- **RCZ: Reload Counter Zero**

0 = Reload Counter Zero interrupt is disabled.

1 = Reload Counter Zero interrupt is enabled.



## 21.5.14 PDCA Interrupt Status Register

**Name:** ISR

**Access Type:** Read-only

31	30	29	28	27	26	25	24
-	-	-	-	-	-	-	-
23	22	21	20	19	18	17	16
-	-	-	-	-	-	-	-
15	14	13	12	11	10	9	8
-	-	-	-	-	-	-	-
7	6	5	4	3	2	1	0
-	-	-	-	-	TERR	TRC	RCZ

- **TERR: Transfer Error**

0 = No transfer errors have occurred.

1 = A transfer error has occurred.

- **TRC: Transfer Complete**

0 = The Transfer Counter Register (TCR) and/or the Transfer Counter Reload Register (TCRR) hold a non-zero value.

1 = Both the Transfer Counter Register (TCR) and the Transfer Counter Reload Register (TCRR) are zero.

- **RCZ: Reload Counter Zero**

0 = The Transfer Counter Reload Register (TCRR) holds a non-zero value.

1 = The Transfer Counter Reload Register (TCRR) is zero.

## 22. General-Purpose Input/Output Controller (GPIO)

Rev. 1.1.0.2

### 22.1 Features

Each I/O line of the GPIO features:

- Configurable pin-change, rising-edge or falling-edge interrupt on any I/O line.
- A glitch filter providing rejection of pulses shorter than one clock cycle.
- Open Drain mode enabling sharing of an I/O line between the MCU and external components.
- Input visibility and output control.
- Multiplexing of up to four peripheral functions per I/O line.
- Programmable internal pull-up resistor.

### 22.2 Overview

The General Purpose Input/Output manages the I/O pins of the microcontroller. Each I/O line may be dedicated as a general-purpose I/O or be assigned to a function of an embedded peripheral. This assures effective optimization of the pins of a product.

**Table 22-1.** Overview of the GPIO system

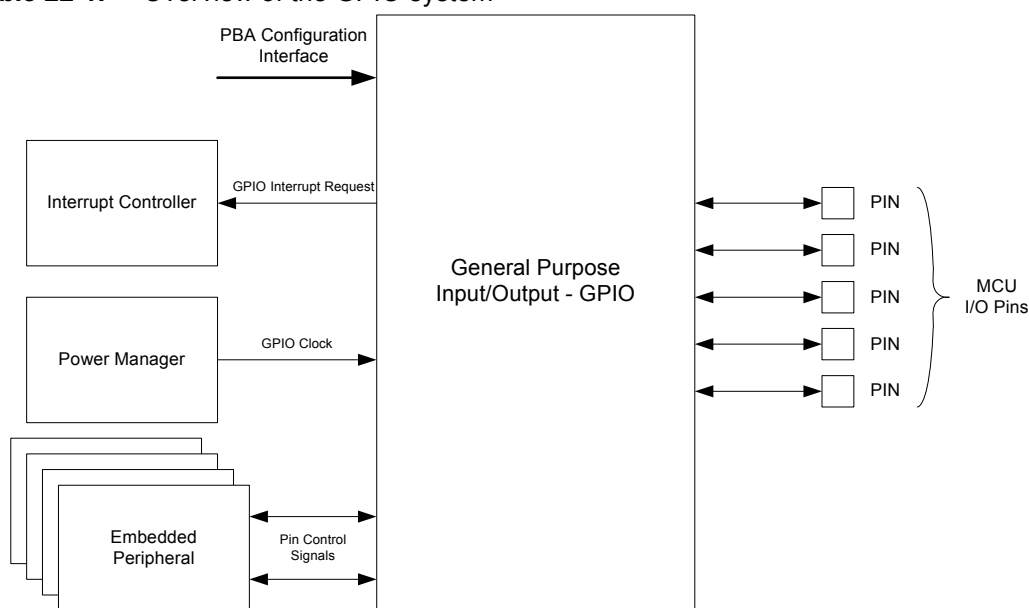

### 22.3 Product dependencies

#### 22.3.1 Module Configuration

Most of the features of the GPIO are configurable for each product. The programmer must refer to the Peripherals Section for these settings.

Product specific settings includes:

- Number of I/O pins.
- Functions implemented on each pin.
- Peripheral function(s) multiplexed on each I/O pin.
- Reset state of registers.

## 22.3.2 Interrupt Lines

The GPIO interrupt lines are connected to the interrupt controller. Using the GPIO interrupt requires the interrupt controller to be programmed first.

## 22.3.3 Power and Clock Management

The clock for the GPIO is controlled by the power manager. The programmer must ensure that the GPIO clock is enabled in the power manager before using the GPIO. The clock must be enabled in order to access the configuration registers of the GPIO and when interrupts are enabled. After configuring the GPIO, the clock can be disabled if interrupts are not enabled.

## 22.4 Functional Description

The GPIO controls the I/O lines of the microcontroller. The control logic associated with each pin is represented in the figure below:

**Figure 22-1.** Overview of the GPIO pad connections

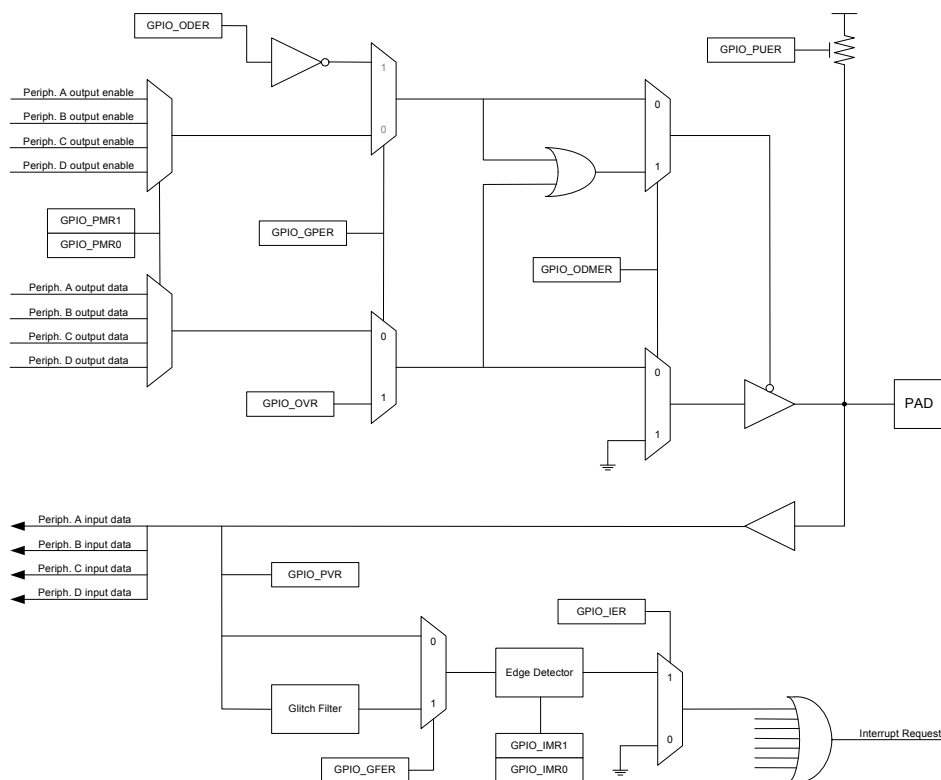

### 22.4.1 Pull-up Resistor Control

Each I/O line is designed with an embedded pull-up resistor. The pull-up resistor can be enabled or disabled by accessing the corresponding bit in PUER (Pull-up Enable Register). Control of the pull-up resistor is possible whether an I/O line is controlled by a peripheral or the GPIO.

#### 22.4.2 I/O Line or Peripheral Function Selection

When a pin is multiplexed with one or more peripheral functions, the selection is controlled with the register GPER. If a bit in the register is set, the corresponding pin is controlled by the GPIO. If a bit is cleared, the corresponding pin is controlled by a peripheral function.

#### 22.4.3 Peripheral Selection

The GPIO provides multiplexing of up to four peripheral functions on a single pin. The selection is performed by accessing PMR0 (Peripheral Mux Register 0) and PMR1 (Peripheral Mux Register 1).

#### 22.4.4 Output Control

When the I/O line is assigned to a peripheral function, i.e. the corresponding bit in GPER is at 0, the drive of the I/O line is controlled by the peripheral. The peripheral, depending on the value in PMR0 and PMR1, determines whether the pin is driven or not.

When the I/O line is controlled by the GPIO, the value of ODER (Output Driver Enable Register) determines if the pin is driven or not. When a bit in this register is at 1, the corresponding I/O line is driven by the GPIO. When the bit is at 0, the GPIO does not drive the line.

The level driven on an I/O line can be determined by writing OVR (Output Value Register).

#### 22.4.5 Open Drain Mode

Each I/O line can be independently programmed to operate in open drain mode. This feature permits several drivers to be connected on the I/O line. The drivers should only actively drive the line low. An external pull-up resistor (or enabling the internal one) is generally required to guarantee a high level on the line when no driver is active.

The Open Drain feature is controlled by ODMER (Open Drain Mode Enable Register). The Open Drain mode can be selected whether the I/O line is controlled by the GPIO or assigned to a peripheral function.

#### 22.4.6 Inputs

The level on each I/O line can be read through PVR (Pin Value Register). This register indicates the level of the I/O lines regardless of whether the lines are driven by the GPIO or by an external component. Note that due to power saving measures, PVR register can only be read when GPER is set for the corresponding pin or if interrupt is enabled for the pin.

##### Output Line Timings

The figure below shows the timing of the I/O line when setting and clearing the Output Value Register by accessing OVR. The same timing applies when performing a 'set' or 'clear' access i.e. writing to OVRS or OVRC. The timing of PVR (Pin Value Register) is also shown.

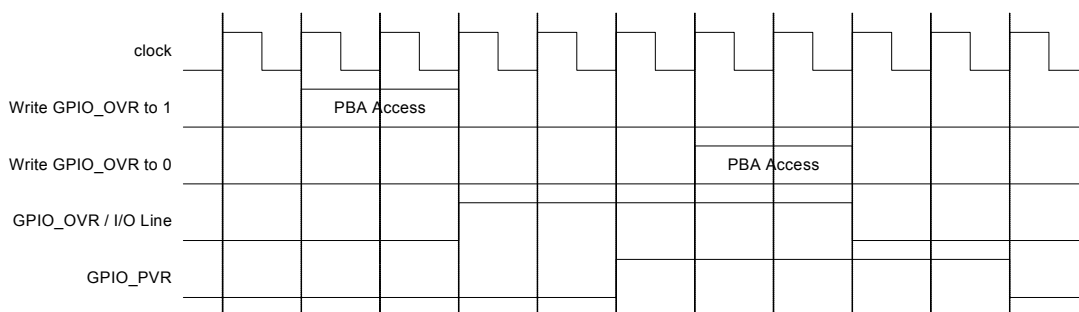
**Figure 22-2.** Output line timings

### 22.4.7 Interrupts

The GPIO can be programmed to generate an interrupt when it detects an input change on an I/O line. The module can be configured to signal an interrupt whenever a pin changes value or only to trigger on rising edges or falling edges. Interrupt is enabled on a pin by setting the corresponding bit in IER (Interrupt Enable Register). The interrupt mode is set by accessing IMR0 (Interrupt Mode Register 0) and IMR1 (Interrupt Mode Register 1). Interrupt can be enabled on a pin, regardless of the configuration the I/O line, i.e. controlled by the GPIO or assigned to a peripheral function.

In every port there are four interrupt lines connected to the interrupt controller. Every eighth interrupts in the port are ored together to form an interrupt line.

When an interrupt event is detected on an I/O line, and the corresponding bit in IER is set, the GPIO interrupt request line is asserted. A number of interrupt signals are ORed-wired together to generate a single interrupt signal to the interrupt controller.

IFR (Interrupt Flag Register) can be read by software to determine which pin(s) caused the interrupt. The interrupt flag must be manually cleared by writing to IFR.

GPIO interrupts can only be triggered when the GPIO clock is enabled.

### 22.4.8 Input Glitch Filter

Optional input glitch filters can be enabled on each I/O line. When the glitch filter is enabled, a glitch with duration of less than 1 clock cycle is automatically rejected, while a pulse with duration of 2 clock cycles or more is accepted. For pulse durations between 1 clock cycle and 2 clock cycles, the pulse may or may not be taken into account, depending on the precise timing of its occurrence. Thus for a pulse to be guaranteed visible it must exceed 2 clock cycles, whereas for a glitch to be reliably filtered out, its duration must not exceed 1 clock cycle. The filter introduces 2 clock cycles latency.

The glitch filters are controlled by the register GFER (Glitch Filter Enable Register). When a bit is set in GFER, the glitch filter on the corresponding pin is enabled. The glitch filter affects only interrupt inputs. Inputs to peripherals or the value read through PVR are not affected by the glitch filters.

### 22.4.9 Interrupt Timings

The figure below shows the timing for rising edge (or pin-change) interrupts when the glitch filter is disabled. For the pulse to be registered, it must be sampled at the rising edge of the clock. In this example, this is not the case for the first pulse. The second pulse is however sampled on a rising edge and will trigger an interrupt request.

**Figure 22-3.** Interrupt timing with glitch filter disabled

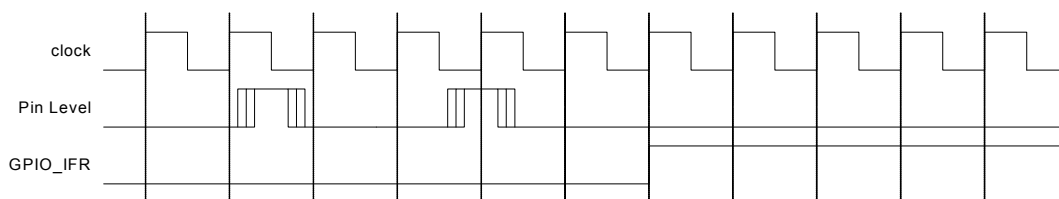

The figure below shows the timing for rising edge (or pin-change) interrupts when the glitch filter is enabled. For the pulse to be registered, it must be sampled on two subsequent rising edges. In the example, the first pulse is rejected while the second pulse is accepted and causes an interrupt request.

**Figure 22-4.** Interrupt timing with glitch filter enabled

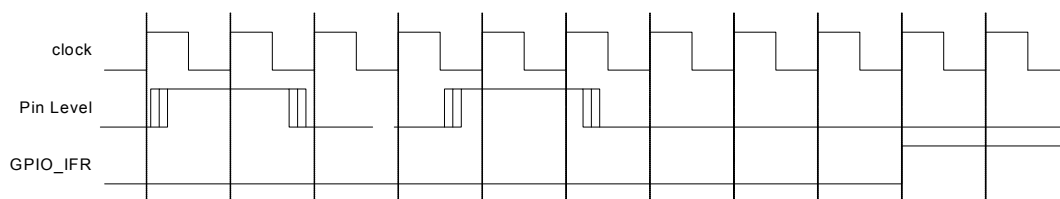

## 22.5 General Purpose Input/Output (GPIO) User Interface

The GPIO controls all the I/O pins on the AVR32 microcontroller. The pins are managed as 32-bit ports that are configurable through an PB interface. Each port has a set of configuration registers. The overall memory map of the GPIO is shown below. The number of pins and hence the number of ports is product specific.

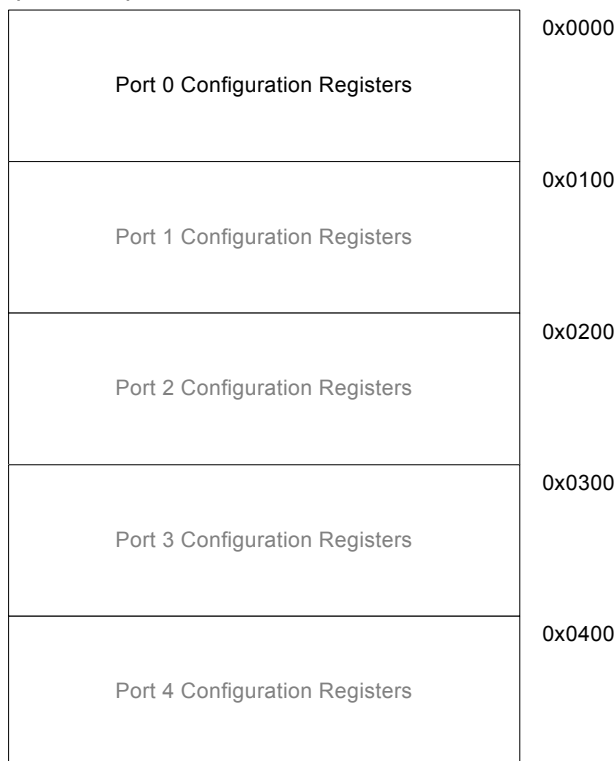

In the Peripheral muxing table in the Peripherals chapter each GPIO line has a unique number. Note that the PA, PB, PC and PX ports do not directly correspond to the GPIO ports. To find the corresponding port and pin the following formulas can be used:

GPIO port = floor((GPIO number) / 32), example: floor((36)/32) = 1

GPIO pin = GPIO number mod 32, example: 36 mod 32 = 4

The table below shows the configuration registers for one port. Addresses shown are relative to the port address offset. The specific address of a configuration register is found by adding the register offset and the port offset to the GPIO start address. One bit in each of the configuration registers corresponds to an I/O pin.

**Table 22-2.** GPIO Register Map

Offset	Register	Function	Name	Access	Reset value
0x00	GPIO Enable Register	Read/Write	GPEN	Read/Write	1b for each implemented GPIO pin in port
0x04	GPIO Enable Register	Set	GPERS	Write-Only	
0x08	GPIO Enable Register	Clear	GPERC	Write-Only	
0x0C	GPIO Enable Register	Toggle	GPERT	Write-Only	
0x10	Peripheral Mux Register 0	Read/Write	PMR0	Read/Write	0x00000000



**Table 22-2. GPIO Register Map**

Offset	Register	Function	Name	Access	Reset value
0x14	Peripheral Mux Register 0	Set	PMR0S	Write-Only	
0x18	Peripheral Mux Register 0	Clear	PMR0C	Write-Only	
0x1C	Peripheral Mux Register 0	Toggle	PMR0T	Write-Only	
0x20	Peripheral Mux Register 1	Read/Write	PMR1	Read/Write	0x00000000
0x24	Peripheral Mux Register 1	Set	PMR1S	Write-Only	
0x28	Peripheral Mux Register 1	Clear	PMR1C	Write-Only	
0x2C	Peripheral Mux Register 1	Toggle	PMR1T	Write-Only	
0x30	RESERVED	-	-	-	
0x34	RESERVED	-	-	-	
0x38	RESERVED	-	-	-	
0x3C	RESERVED	-	-	-	
0x40	Output Driver Enable Register	Read/Write	ODER	Read/Write	0x00000000
0x44	Output Driver Enable Register	Set	ODERS	Write-Only	
0x48	Output Driver Enable Register	Clear	ODERC	Write-Only	
0x4C	Output Driver Enable Register	Toggle	ODERT	Write-Only	
0x50	Output Value Register	Read/Write	OVR	Read/Write	0x00000000
0x54	Output Value Register	Set	OVRS	Write-Only	
0x58	Output Value Register	Clear	OVRC	Write-Only	
0x5c	Output Value Register	Toggle	OVRT	Write-Only	
0x60	Pin Value Register	Read	PVR	Read-Only	depending on pin states
0x64	Pin Value Register	-	-	-	
0x68	Pin Value Register	-	-	-	
0x6c	Pin Value Register	-	-	-	
0x70	Pull-up Enable Register	Read/Write	PUER	Read/Write	0x00000000
0x74	Pull-up Enable Register	Set	PUERS	Write-Only	
0x78	Pull-up Enable Register	Clear	PUERC	Write-Only	
0x7C	Pull-up Enable Register	Toggle	PUERT	Write-Only	
0x80	Open Drain Mode Enable Register	Read/Write	ODMER	Read/Write	0x00000000
0x84	Open Drain Mode Enable Register	Set	ODMERS	Write-Only	
0x88	Open Drain Mode Enable Register	Clear	ODMERC	Write-Only	
0x8C	Open Drain Mode Enable Register	Toggle	ODMERT	Write-Only	
0x90	Interrupt Enable Register	Read/Write	IER	Read/Write	0x00000000
0x94	Interrupt Enable Register	Set	IERS	Write-Only	
0x98	Interrupt Enable Register	Clear	IERC	Write-Only	
0x9C	Interrupt Enable Register	Toggle	IERT	Write-Only	



**Table 22-2. GPIO Register Map**

Offset	Register	Function	Name	Access	Reset value
0xA0	Interrupt Mode Register 0	Read/Write	IMR0	Read/Write	0x00000000
0xA4	Interrupt Mode Register 0	Set	IMR0S	Write-Only	
0xA8	Interrupt Mode Register 0	Clear	IMR0C	Write-Only	
0xAC	Interrupt Mode Register 0	Toggle	IMR0T	Write-Only	
0xB0	Interrupt Mode Register 1	Read/Write	IMR1	Read/Write	0x00000000
0xB4	Interrupt Mode Register 1	Set	IMR1S	Write-Only	
0xB8	Interrupt Mode Register 1	Clear	IMR1C	Write-Only	
0xBC	Interrupt Mode Register 1	Toggle	IMR1T	Write-Only	
0xC0	Glitch Filter Enable Register	Read/Write	GFER	Read/Write	1b for each implemented GPIO pin in port
0xC4	Glitch Filter Enable Register	Set	GFERS	Write-Only	
0xC8	Glitch Filter Enable Register	Clear	GFERC	Write-Only	
0xCC	Glitch Filter Enable Register	Toggle	GFERT	Write-Only	
0xD0	Interrupt Flag Register	Read	IFR	Read-Only	0x00000000
0xD4	Interrupt Flag Register	-	-	-	
0xD8	Interrupt Flag Register	Clear	IFRC	Write-Only	
0xDC	Interrupt Flag Register	-	-	-	
0xE0-0xFF	RESERVED	-	-	-	

### 22.5.1 Access Types

Each configuration register can be accessed in four different ways. The first address location can be used to write the register directly. This address can also be used to read the register value. The following addresses facilitate three different types of write access to the register. Performing a “set” access, all bits written to ‘1’ will be set. Bits written to ‘0’ will be unchanged by the operation. Performing a “clear” access, all bits written to ‘1’ will be cleared. Bits written to ‘0’ will be unchanged by the operation. Finally, a toggle access will toggle the value of all bits written to ‘1’. Again all bits written to ‘0’ remain unchanged. Note that for some registers (e.g. IFR), not all access methods are permitted.

Note that for ports with less than 32 bits, the corresponding control registers will have unused bits. This is also the case for features that are not implemented for a specific pin. Writing to an unused bit will have no effect. Reading unused bits will always return 0.



## 22.5.2 GPIO Enable Register

**Name:** GPER

**Access:** Read, Write, Set, Clear, Toggle

31	30	29	28	27	26	25	24
P31	P30	P29	P28	P27	P26	P25	P24
23	22	21	20	19	18	17	16
P23	P22	P21	P20	P19	P18	P17	P16
15	14	13	12	11	10	9	8
P15	P14	P13	P12	P11	P10	P9	P8
7	6	5	4	3	2	1	0
P7	P6	P5	P4	P3	P2	P1	P0

- **P0-P31: GPIO Enable**

0 = A peripheral function controls the corresponding pin.

1 = The GPIO controls the corresponding pin.

## 22.5.3 Peripheral Mux Register 0

**Name:** PMR0

**Access:** Read, Write, Set, Clear, Toggle

31	30	29	28	27	26	25	24
P31	P30	P29	P28	P27	P26	P25	P24
23	22	21	20	19	18	17	16
P23	P22	P21	P20	P19	P18	P17	P16
15	14	13	12	11	10	9	8
P15	P14	P13	P12	P11	P10	P9	P8
7	6	5	4	3	2	1	0
P7	P6	P5	P4	P3	P2	P1	P0

- **P0-31: Peripheral Multiplexer Select bit 0**

## 22.5.4 Peripheral Mux Register 1

**Name:** PMR1

**Access:** Read, Write, Set, Clear, Toggle

31	30	29	28	27	26	25	24
P31	P30	P29	P28	P27	P26	P25	P24
23	22	21	20	19	18	17	16
P23	P22	P21	P20	P19	P18	P17	P16
15	14	13	12	11	10	9	8
P15	P14	P13	P12	P11	P10	P9	P8
7	6	5	4	3	2	1	0
P7	P6	P5	P4	P3	P2	P1	P0

- **P0-31: Peripheral Multiplexer Select bit 1**

{PMR1, PMR0}	Selected Peripheral Function
00	A
01	B
10	C
11	D

## 22.5.5 Output Driver Enable Register

**Name:** ODER

**Access:** Read, Write, Set, Clear, Toggle

31	30	29	28	27	26	25	24
P31	P30	P29	P28	P27	P26	P25	P24
23	22	21	20	19	18	17	16
P23	P22	P21	P20	P19	P18	P17	P16
15	14	13	12	11	10	9	8
P15	P14	P13	P12	P11	P10	P9	P8
7	6	5	4	3	2	1	0
P7	P6	P5	P4	P3	P2	P1	P0

- **P0-31: Output Driver Enable**

0 = The output driver is disabled for the corresponding pin.

1 = The output driver is enabled for the corresponding pin.

## 22.5.6 Output Value Register

**Name:** OVR

**Access:** Read, Write, Set, Clear, Toggle

31	30	29	28	27	26	25	24
P31	P30	P29	P28	P27	P26	P25	P24
23	22	21	20	19	18	17	16
P23	P22	P21	P20	P19	P18	P17	P16
15	14	13	12	11	10	9	8
P15	P14	P13	P12	P11	P10	P9	P8
7	6	5	4	3	2	1	0
P7	P6	P5	P4	P3	P2	P1	P0

- **P0-31: Output Value**

0 = The value to be driven on the I/O line is 0.

1 = The value to be driven on the I/O line is 1.

## 22.5.7 Pin Value Register

**Name:** PVR

**Access:** Read

31	30	29	28	27	26	25	24
P31	P30	P29	P28	P27	P26	P25	P24
23	22	21	20	19	18	17	16
P23	P22	P21	P20	P19	P18	P17	P16
15	14	13	12	11	10	9	8
P15	P14	P13	P12	P11	P10	P9	P8
7	6	5	4	3	2	1	0
P7	P6	P5	P4	P3	P2	P1	P0

- **P0-31: Pin Value**

0 = The I/O line is at level '0'.

1 = The I/O line is at level '1'.

Note that the level of a pin can only be read when GPER is set or interrupt is enabled for the pin.

## 22.5.8 Pull-up Enable Register

**Name:** PUER

**Access:** Read, Write, Set, Clear, Toggle

31	30	29	28	27	26	25	24
P31	P30	P29	P28	P27	P26	P25	P24
23	22	21	20	19	18	17	16
P23	P22	P21	P20	P19	P18	P17	P16
15	14	13	12	11	10	9	8
P15	P14	P13	P12	P11	P10	P9	P8
7	6	5	4	3	2	1	0
P7	P6	P5	P4	P3	P2	P1	P0

- **P0-31: Pull-up Enable**

0 = The internal pull-up resistor is disabled for the corresponding pin.

1 = The internal pull-up resistor is enabled for the corresponding pin.

## 22.5.9 Open Drain Mode Enable Register

**Name:** ODMER

**Access:** Read, Write, Set, Clear, Toggle

31	30	29	28	27	26	25	24
P31	P30	P29	P28	P27	P26	P25	P24
23	22	21	20	19	18	17	16
P23	P22	P21	P20	P19	P18	P17	P16
15	14	13	12	11	10	9	8
P15	P14	P13	P12	P11	P10	P9	P8
7	6	5	4	3	2	1	0
P7	P6	P5	P4	P3	P2	P1	P0

- **P0-31: Open Drain Mode Enable**

0 = Open drain mode is disabled for the corresponding pin.

1 = Open drain mode is enabled for the corresponding pin.



## 22.5.10 Interrupt Enable Register

**Name:** IER

**Access:** Read, Write, Set, Clear, Toggle

31	30	29	28	27	26	25	24
P31	P30	P29	P28	P27	P26	P25	P24
23	22	21	20	19	18	17	16
P23	P22	P21	P20	P19	P18	P17	P16
15	14	13	12	11	10	9	8
P15	P14	P13	P12	P11	P10	P9	P8
7	6	5	4	3	2	1	0
P7	P6	P5	P4	P3	P2	P1	P0

- **P0-31: Interrupt Enable**

0 = Interrupt is disabled for the corresponding pin.

1 = Interrupt is enabled for the corresponding pin.

## 22.5.11 Interrupt Mode Register 0

**Name:** IMR0

**Access:** Read, Write, Set, Clear, Toggle

31	30	29	28	27	26	25	24
P31	P30	P29	P28	P27	P26	P25	P24
23	22	21	20	19	18	17	16
P23	P22	P21	P20	P19	P18	P17	P16
15	14	13	12	11	10	9	8
P15	P14	P13	P12	P11	P10	P9	P8
7	6	5	4	3	2	1	0
P7	P6	P5	P4	P3	P2	P1	P0

- P0-31: Interrupt Mode Bit 0

## 22.5.12 Interrupt Mode Register 1

**Name:** IMR1

**Access:** Read, Write, Set, Clear, Toggle

31	30	29	28	27	26	25	24
P31	P30	P29	P28	P27	P26	P25	P24
23	22	21	20	19	18	17	16
P23	P22	P21	P20	P19	P18	P17	P16
15	14	13	12	11	10	9	8
P15	P14	P13	P12	P11	P10	P9	P8
7	6	5	4	3	2	1	0
P7	P6	P5	P4	P3	P2	P1	P0

- P0-31: Interrupt Mode Bit 1

{IMR1, IMR0}	Interrupt Mode
00	Pin Change
01	Rising Edge
10	Falling Edge
11	Reserved

## 22.5.13 Glitch Filter Enable Register

**Name:** GFER

**Access:** Read, Write, Set, Clear, Toggle

31	30	29	28	27	26	25	24
P31	P30	P29	P28	P27	P26	P25	P24
23	22	21	20	19	18	17	16
P23	P22	P21	P20	P19	P18	P17	P16
15	14	13	12	11	10	9	8
P15	P14	P13	P12	P11	P10	P9	P8
7	6	5	4	3	2	1	0
P7	P6	P5	P4	P3	P2	P1	P0

- **P0-31: Glitch Filter Enable**

0 = Glitch filter is disabled for the corresponding pin.

1 = Glitch filter is enabled for the corresponding pin.

NOTE! The value of this register should only be changed when IER is '0'. Updating this GFER while interrupt on the corresponding pin is enabled can cause an unintentional interrupt to be triggered.

## 22.5.14 Interrupt Flag Register

**Name:** IFR

**Access:** Read, Clear

31	30	29	28	27	26	25	24
P31	P30	P29	P28	P27	P26	P25	P24
23	22	21	20	19	18	17	16
P23	P22	P21	P20	P19	P18	P17	P16
15	14	13	12	11	10	9	8
P15	P14	P13	P12	P11	P10	P9	P8
7	6	5	4	3	2	1	0
P7	P6	P5	P4	P3	P2	P1	P0

- **P0-31: Interrupt Flag**

0 = An interrupt condition has been detected on the corresponding pin.

1 = No interrupt condition has been detected on the corresponding pin.

The number of interrupt request lines is dependant on the number of I/O pins on the MCU. Refer to the product specific data for details. Note also that a bit in the Interrupt Flag register is only valid if the corresponding bit in IER is set.

## 22.6 Programming Examples

### 22.6.1 8-bit LED-Chaser

```

// Set R0 to GPIO base address
mov    R0, LO(AVR32_GPIO_BASE_ADDRESS)
orh    R0, HI(AVR32_GPIO_BASE_ADDRESS)

// Enable GPIO control of pin 0-8
mov    R1, 0xFF
st.w   R0[AVR32_GPIO_GPERS], R1

// Set initial value of port
mov    R2, 0x01
st.w   R0[AVR32_GPIO_OVRS], R2

// Set up toggle value. Two pins are toggled
// in each round. The bit that is currently set,
// and the next bit to be set.
mov    R2, 0x0303
orh    R2, 0x0303

loop:
// Only change 8 LSB
mov    R3, 0x00FF
and    R3, R2
st.w   R0[AVR32_GPIO_OVRT], R3
rol    R2
rcall  delay
rjmp  loop

```

It is assumed in this example that a subroutine "delay" exists that returns after a given time.

### 22.6.2 Configuration of USART pins

The example below shows how to configure a peripheral module to control I/O pins. It assumed in this example that the USART receive pin (RXD) is connected to PC16 and that the USART transmit pin (TXD) is connected to PC17. For both pins, the USART is peripheral B. In this example, the state of the GPIO registers is assumed to be unknown. The two USART pins are therefore first set to be controlled by the GPIO with output drivers disabled. The pins can then be assured to be tri-stated while changing the Peripheral Mux Registers.

```

// Set up pointer to GPIO, PORTC
mov    R0, LO(AVR32_GPIO_BASE_ADDRESS + PORTC_OFFSET)
orh    R0, HI(AVR32_GPIO_BASE_ADDRESS + PORTC_OFFSET)

// Disable output drivers

```

```
mov    R1, 0x0000
orh    R1, 0x0003
st.w   R0[AVR32_GPIO_ODERC], R1

// Make the GPIO control the pins
st.w   R0[AVR32_GPIO_GPERS], R1

// Select peripheral B on PC16-PC17
st.w   R0[AVR32_GPIO_PMR0S], R1
st.w   R0[GPIO_PMR1C], R1

// Enable peripheral control
st.w   R0[AVR32_GPIO_GPERC], R1
```

## 23. Serial Peripheral Interface (SPI)

Rev: 1.9.9.3

### 23.1 Features

- **Supports Communication with Serial External Devices**
  - Four Chip Selects with External Decoder Support Allow Communication with Up to 15 Peripherals
  - Serial Memories, such as DataFlash and 3-wire EEPROMs
  - Serial Peripherals, such as ADCs, DACs, LCD Controllers, CAN Controllers and Sensors
  - External Co-processors
- **Master or Slave Serial Peripheral Bus Interface**
  - 8- to 16-bit Programmable Data Length Per Chip Select
  - Programmable Phase and Polarity Per Chip Select
  - Programmable Transfer Delays Between Consecutive Transfers and Between Clock and Data Per Chip Select
  - Programmable Delay Between Consecutive Transfers
  - Selectable Mode Fault Detection
- **Connection to PDC Channel Capabilities Optimizes Data Transfers**
  - One Channel for the Receiver, One Channel for the Transmitter
  - Next Buffer Support

### 23.2 Description

The Serial Peripheral Interface (SPI) circuit is a synchronous serial data link that provides communication with external devices in Master or Slave Mode. It also enables communication between processors if an external processor is connected to the system.

The Serial Peripheral Interface is essentially a shift register that serially transmits data bits to other SPIs. During a data transfer, one SPI system acts as the "master" which controls the data flow, while the other devices act as "slaves" which have data shifted into and out by the master. Different CPUs can take turn being masters (Multiple Master Protocol opposite to Single Master Protocol where one CPU is always the master while all of the others are always slaves) and one master may simultaneously shift data into multiple slaves. However, only one slave may drive its output to write data back to the master at any given time.

A slave device is selected when the master asserts its NSS signal. If multiple slave devices exist, the master generates a separate slave select signal for each slave (NPCS).

The SPI system consists of two data lines and two control lines:

- **Master Out Slave In (MOSI):** This data line supplies the output data from the master shifted into the input(s) of the slave(s).
- **Master In Slave Out (MISO):** This data line supplies the output data from a slave to the input of the master. There may be no more than one slave transmitting data during any particular transfer.
- **Serial Clock (SPCK):** This control line is driven by the master and regulates the flow of the data bits. The master may transmit data at a variety of baud rates; the SPCK line cycles once for each bit that is transmitted.
- **Slave Select (NSS):** This control line allows slaves to be turned on and off by hardware.

23.3 Block Diagram

Figure 23-1. Block Diagram

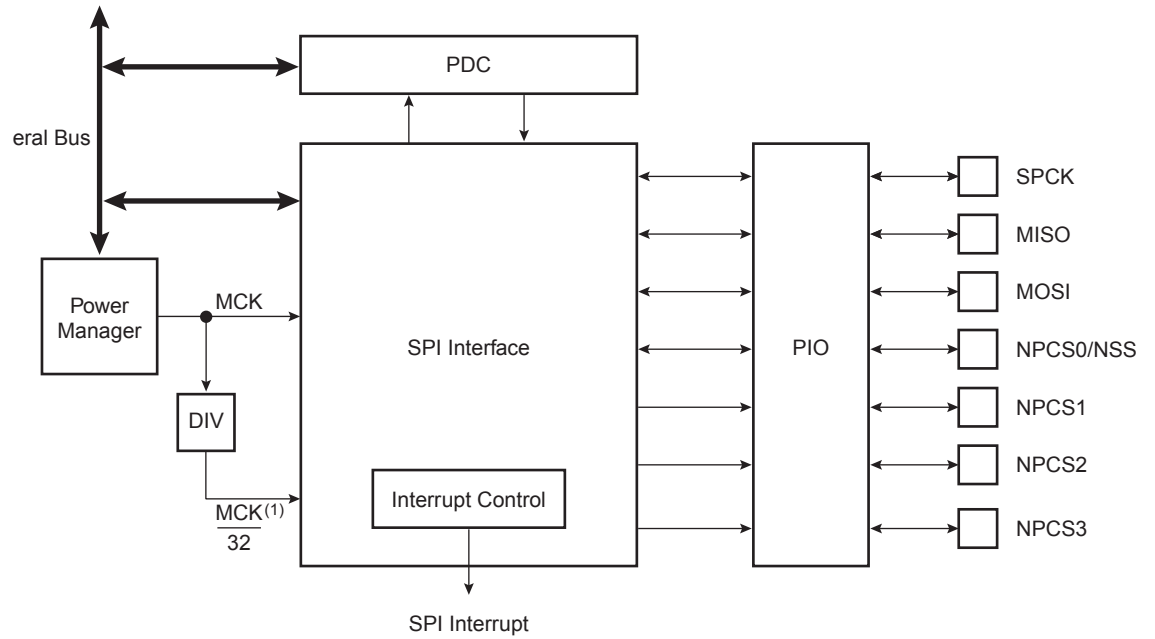



### 23.4 Application Block Diagram

Figure 23-2. Application Block Diagram: Single Master/Multiple Slave Implementation

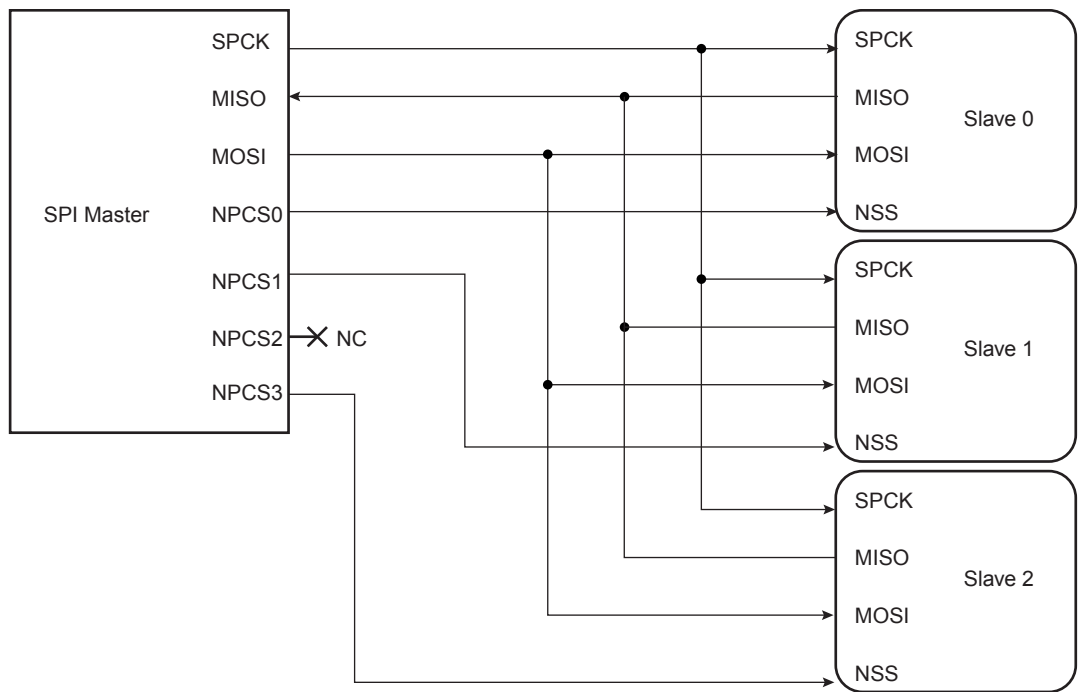

## 23.5 Signal Description

**Table 23-1.** Signal Description

Pin Name	Pin Description	Type	
		Master	Slave
MISO	Master In Slave Out	Input	Output
MOSI	Master Out Slave In	Output	Input
SPCK	Serial Clock	Output	Input
NPCS1-NPCS3	Peripheral Chip Selects	Output	Unused
NPCS0/NSS	Peripheral Chip Select/Slave Select	Output	Input

## 23.6 Product Dependencies

### 23.6.1 I/O Lines

The pins used for interfacing the compliant external devices may be multiplexed with PIO lines. The programmer must first program the PIO controllers to assign the SPI pins to their peripheral functions. To use the local loopback function the SPI pins must be controlled by the SPI.

### 23.6.2 Power Management

The SPI clock is generated by the Power Manager. Before using the SPI, the programmer must ensure that the SPI clock is enabled in the Power Manager.

In the SPI description, Master Clock (MCK) is the clock of the peripheral bus to which the SPI is connected.

### 23.6.3 Interrupt

The SPI interface has an interrupt line connected to the Interrupt Controller. Handling the SPI interrupt requires programming the interrupt controller before configuring the SPI.

## 23.7 Functional Description

### 23.7.1 Modes of Operation

The SPI operates in Master Mode or in Slave Mode.

Operation in Master Mode is programmed by writing at 1 the MSTR bit in the Mode Register. The pins NPCS0 to NPCS3 are all configured as outputs, the SPCK pin is driven, the MISO line is wired on the receiver input and the MOSI line driven as an output by the transmitter.

If the MSTR bit is written at 0, the SPI operates in Slave Mode. The MISO line is driven by the transmitter output, the MOSI line is wired on the receiver input, the SPCK pin is driven by the transmitter to synchronize the receiver. The NPCS0 pin becomes an input, and is used as a Slave Select signal (NSS). The pins NPCS1 to NPCS3 are not driven and can be used for other purposes.

The data transfers are identically programmable for both modes of operations. The baud rate generator is activated only in Master Mode.

### 23.7.2 Data Transfer

Four combinations of polarity and phase are available for data transfers. The clock polarity is programmed with the CPOL bit in the Chip Select Register. The clock phase is programmed with the NCPHA bit. These two parameters determine the edges of the clock signal on which data is driven and sampled. Each of the two parameters has two possible states, resulting in four possible combinations that are incompatible with one another. Thus, a master/slave pair must use the same parameter pair values to communicate. If multiple slaves are used and fixed in different configurations, the master must reconfigure itself each time it needs to communicate with a different slave.

Table 23-2 shows the four modes and corresponding parameter settings.

**Table 23-2.** SPI Bus Protocol Mode

SPI Mode	CPOL	NCPHA
0	0	1
1	0	0
2	1	1
3	1	0

Figure 23-3 and Figure 23-4 show examples of data transfers.

**Figure 23-3.** SPI Transfer Format (NCPHA = 1, 8 bits per transfer)

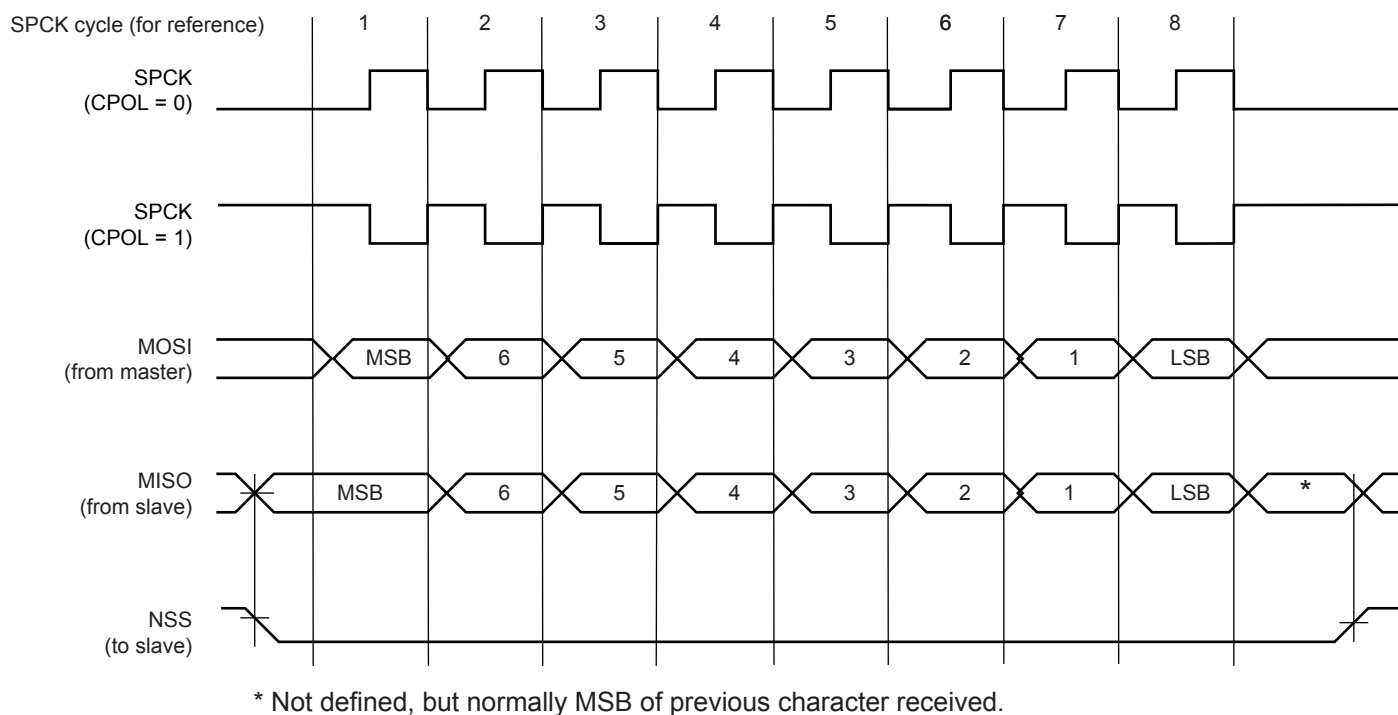

**Figure 23-4.** SPI Transfer Format (NCPHA = 0, 8 bits per transfer)

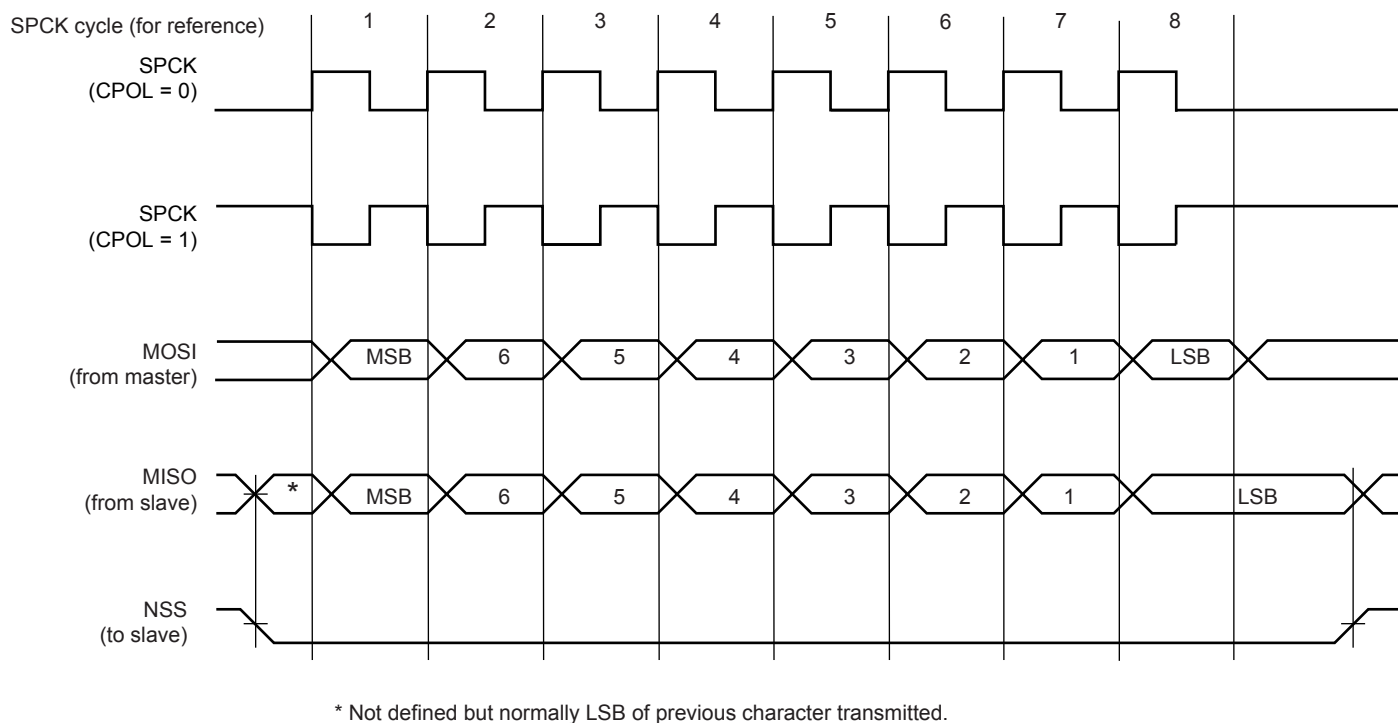

### 23.7.3 Master Mode Operations

When configured in Master Mode, the SPI uses the internal programmable baud rate generator as clock source. It fully controls the data transfers to and from the slave(s) connected to the SPI bus. The SPI drives the chip select line to the slave and the serial clock signal (SPCK).

The SPI features two holding registers, the Transmit Data Register and the Receive Data Register, and a single Shift Register. The holding registers maintain the data flow at a constant rate.

After enabling the SPI, a data transfer begins when the processor writes to the TDR (Transmit Data Register). The written data is immediately transferred in the Shift Register and transfer on the SPI bus starts. While the data in the Shift Register is shifted on the MOSI line, the MISO line is sampled and shifted in the Shift Register. Transmission cannot occur without reception.

Before writing the TDR, the PCS field must be set in order to select a slave.

If new data is written in TDR during the transfer, it stays in it until the current transfer is completed. Then, the received data is transferred from the Shift Register to RDR, the data in TDR is loaded in the Shift Register and a new transfer starts.

The transfer of a data written in TDR in the Shift Register is indicated by the TDRE bit (Transmit Data Register Empty) in the Status Register (SR). When new data is written in TDR, this bit is cleared. The TDRE bit is used to trigger the Transmit PDC channel.

The end of transfer is indicated by the TXEMPTY flag in the SR register. If a transfer delay (DLY-BCT) is greater than 0 for the last transfer, TXEMPTY is set after the completion of said delay. The master clock (MCK) can be switched off at this time.

The transfer of received data from the Shift Register in RDR is indicated by the RDRF bit (Receive Data Register Full) in the Status Register (SR). When the received data is read, the RDRF bit is cleared.

If the RDR (Receive Data Register) has not been read before new data is received, the Overrun Error bit (OVRES) in SR is set. When this bit is set the SPI will continue to update RDR when data is received, overwriting the previously received data. The user has to read the status register to clear the OVRES bit.

[Figure 23-5 on page 199](#) shows a block diagram of the SPI when operating in Master Mode. [Figure 23-6 on page 200](#) shows a flow chart describing how transfers are handled.

## 23.7.3.1 Master Mode Block Diagram

**Figure 23-5.** Master Mode Block Diagram

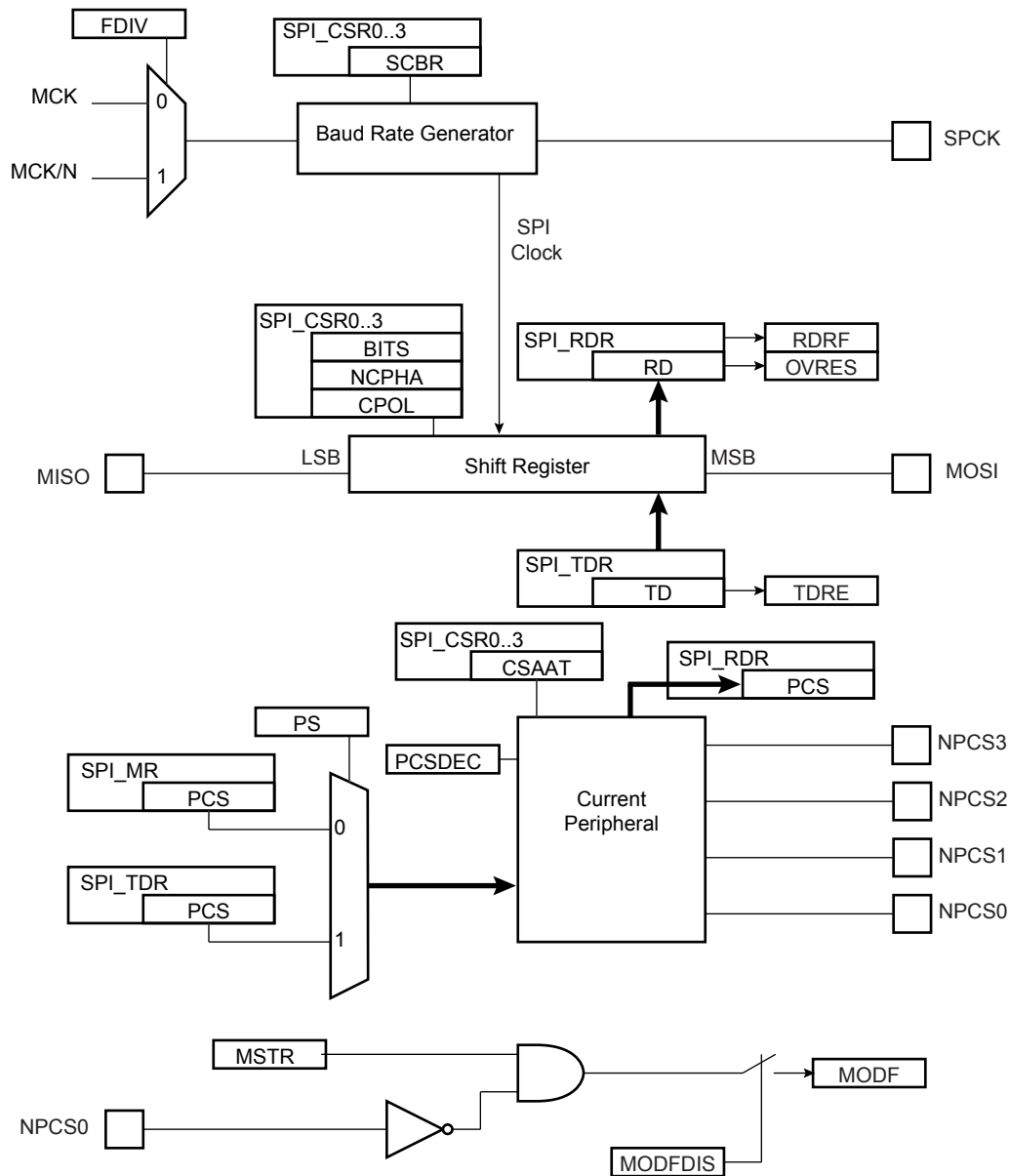

## 23.7.3.2 Master Mode Flow Diagram

**Figure 23-6. Master Mode Flow Diagram S**

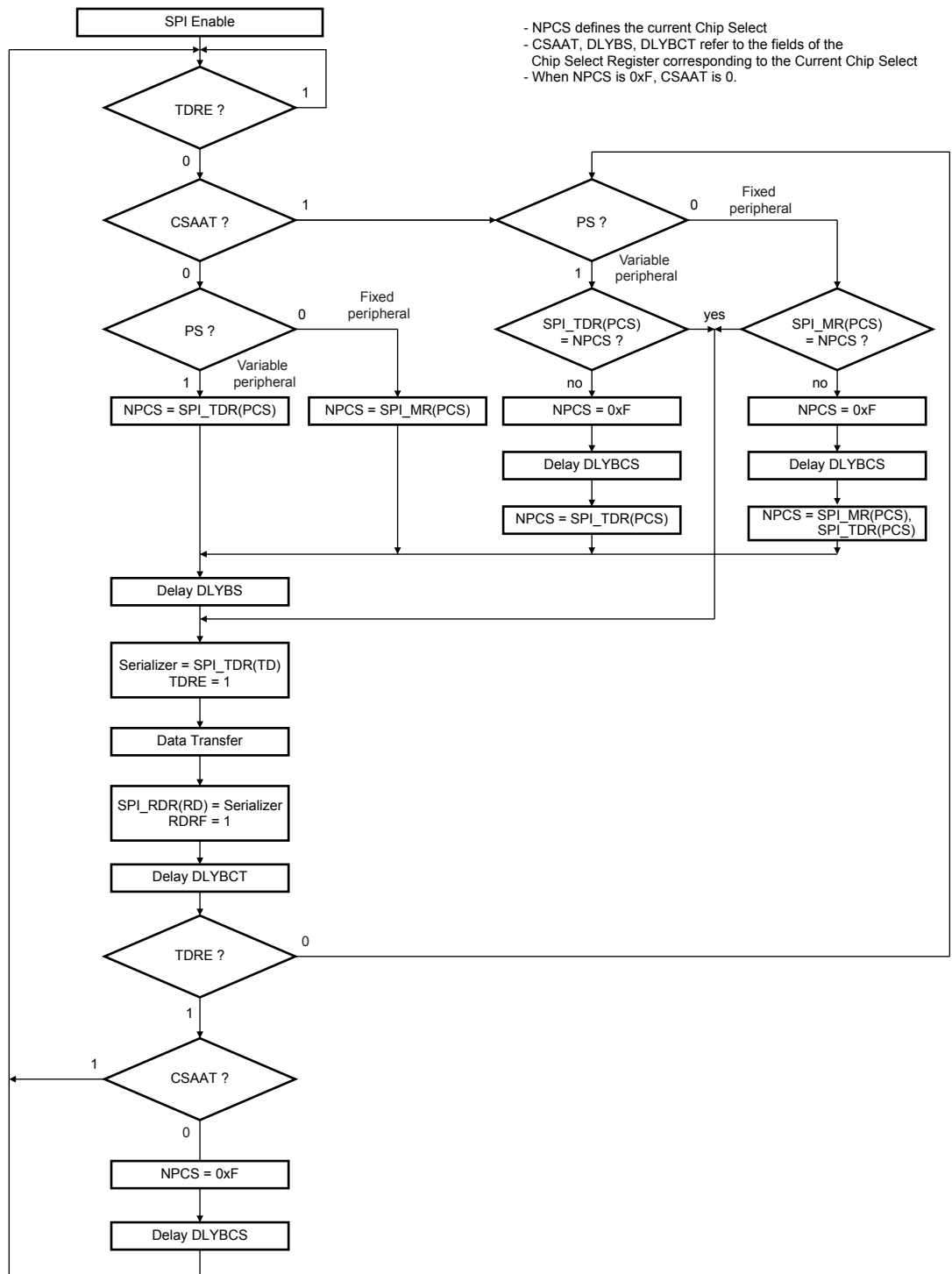



### 23.7.3.3 Clock Generation

The SPI Baud rate clock is generated by dividing the Master Clock (MCK) or the Master Clock divided by 32, by a value between 1 and 255. The selection between Master Clock or Master Clock divided by 32 is done by the FDIV value set in the Mode Register

This allows a maximum operating baud rate at up to Master Clock and a minimum operating baud rate of MCK divided by 255\*32.

Programming the SCBR field at 0 is forbidden. Triggering a transfer while SCBR is at 0 can lead to unpredictable results.

At reset, SCBR is 0 and the user has to program it at a valid value before performing the first transfer.

The divisor can be defined independently for each chip select, as it has to be programmed in the SCBR field of the Chip Select Registers. This allows the SPI to automatically adapt the baud rate for each interfaced peripheral without reprogramming.

### 23.7.3.4 Transfer Delays

Figure 23-7 shows a chip select transfer change and consecutive transfers on the same chip select. Three delays can be programmed to modify the transfer waveforms:

- The delay between chip selects, programmable only once for all the chip selects by writing the DLYBCS field in the Mode Register. Allows insertion of a delay between release of one chip select and before assertion of a new one.
- The delay before SPCK, independently programmable for each chip select by writing the field DLYBS. Allows the start of SPCK to be delayed after the chip select has been asserted.
- The delay between consecutive transfers, independently programmable for each chip select by writing the DLYBCT field. Allows insertion of a delay between two transfers occurring on the same chip select

These delays allow the SPI to be adapted to the interfaced peripherals and their speed and bus release time.

**Figure 23-7.** Programmable Delays

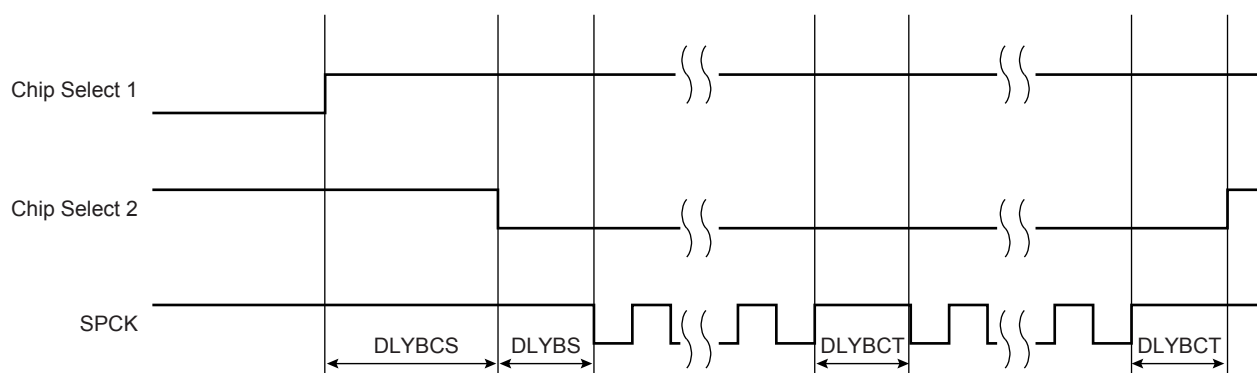

### 23.7.3.5 Peripheral Selection

The serial peripherals are selected through the assertion of the NPCS0 to NPCS3 signals. By default, all the NPCS signals are high before and after each transfer.

The peripheral selection can be performed in two different ways:

- Fixed Peripheral Select: SPI exchanges data with only one peripheral
- Variable Peripheral Select: Data can be exchanged with more than one peripheral

Fixed Peripheral Select is activated by writing the PS bit to zero in MR (Mode Register). In this case, the current peripheral is defined by the PCS field in MR and the PCS field in TDR have no effect.

Variable Peripheral Select is activated by setting PS bit to one. The PCS field in TDR is used to select the current peripheral. This means that the peripheral selection can be defined for each new data.

The Fixed Peripheral Selection allows buffer transfers with a single peripheral. Using the PDC is an optimal means, as the size of the data transfer between the memory and the SPI is either 8 bits or 16 bits. However, changing the peripheral selection requires the Mode Register to be reprogrammed.

The Variable Peripheral Selection allows buffer transfers with multiple peripherals without reprogramming the Mode Register. Data written in TDR is 32 bits wide and defines the real data to be transmitted and the peripheral it is destined to. Using the PDC in this mode requires 32-bit wide buffers, with the data in the LSBs and the PCS and LASTXFER fields in the MSBs, however the SPI still controls the number of bits (8 to 16) to be transferred through MISO and MOSI lines with the chip select configuration registers. This is not the optimal means in term of memory size for the buffers, but it provides a very effective means to exchange data with several peripherals without any intervention of the processor.

### 23.7.3.6 Peripheral Chip Select Decoding

The user can program the SPI to operate with up to 15 peripherals by decoding the four Chip Select lines, NPCS0 to NPCS3 with an external logic. This can be enabled by writing the PCS-DEC bit at 1 in the Mode Register (MR).

When operating without decoding, the SPI makes sure that in any case only one chip select line is activated, i.e. driven low at a time. If two bits are defined low in a PCS field, only the lowest numbered chip select is driven low.

When operating with decoding, the SPI directly outputs the value defined by the PCS field of either the Mode Register or the Transmit Data Register (depending on PS).

As the SPI sets a default value of 0xF on the chip select lines (i.e. all chip select lines at 1) when not processing any transfer, only 15 peripherals can be decoded.

The SPI has only four Chip Select Registers, not 15. As a result, when decoding is activated, each chip select defines the characteristics of up to four peripherals. As an example, CRS0 defines the characteristics of the externally decoded peripherals 0 to 3, corresponding to the PCS values 0x0 to 0x3. Thus, the user has to make sure to connect compatible peripherals on the decoded chip select lines 0 to 3, 4 to 7, 8 to 11 and 12 to 14.

## 23.7.3.7 Peripheral Deselection

When operating normally, as soon as the transfer of the last data written in TDR is completed, the NPCS lines all rise. This might lead to runtime error if the processor is too long in responding to an interrupt, and thus might lead to difficulties for interfacing with some serial peripherals requiring the chip select line to remain active during a full set of transfers.

To facilitate interfacing with such devices, the Chip Select Register can be programmed with the CSAAT bit (Chip Select Active After Transfer) at 1. This allows the chip select lines to remain in their current state (low = active) until transfer to another peripheral is required.

Figure 23-8 shows different peripheral deselection cases and the effect of the CSAAT bit.

**Figure 23-8.** Peripheral Deselection

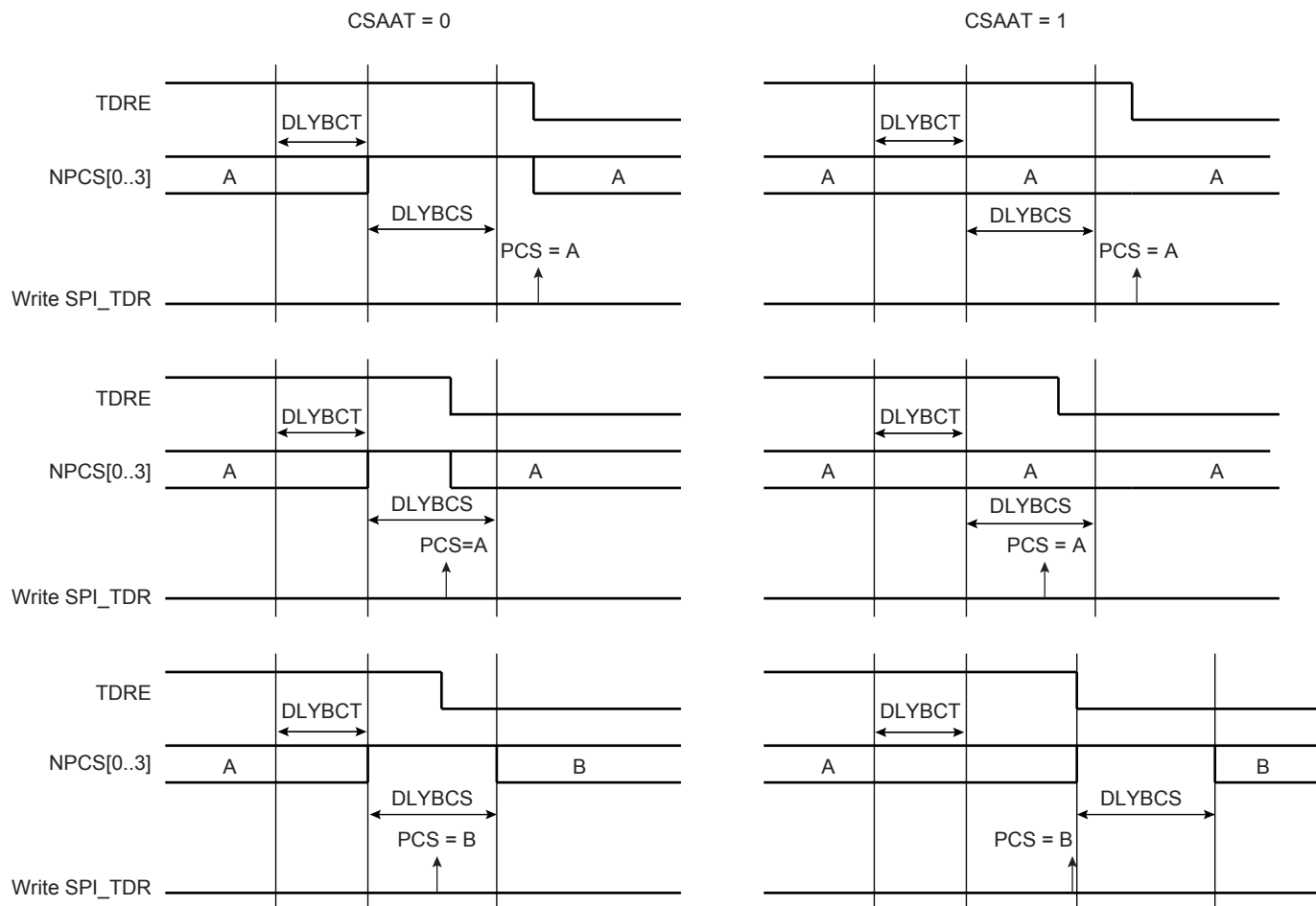

### 23.7.3.8 Mode Fault Detection

A mode fault is detected when the SPI is programmed in Master Mode and a low level is driven by an external master on the NPCSS0/NSS signal. NPCSS0, MOSI, MISO and SPCK must be configured in open-drain through the PIO controller, so that external pull up resistors are needed to guarantee high level.

When a mode fault is detected, the MODF bit in the SR is set until the SR is read and the SPI is automatically disabled until re-enabled by writing the SPIEN bit in the CR (Control Register) at 1.

By default, the Mode Fault detection circuitry is enabled. The user can disable Mode Fault detection by setting the MODFDIS bit in the SPI Mode Register (MR).

### 23.7.4 SPI Slave Mode

When operating in Slave Mode, the SPI processes data bits on the clock provided on the SPI clock pin (SPCK).

The SPI waits for NSS to go active before receiving the serial clock from an external master. When NSS falls, the clock is validated on the serializer, which processes the number of bits defined by the BITS field of the Chip Select Register 0 (CSR0). These bits are processed following a phase and a polarity defined respectively by the NCPHA and CPOL bits of the CSR0. Note that BITS, CPOL and NCPHA of the other Chip Select Registers have no effect when the SPI is programmed in Slave Mode.

The bits are shifted out on the MISO line and sampled on the MOSI line.

When all the bits are processed, the received data is transferred in the Receive Data Register and the RDRF bit rises. If RDRF is already high when the data is transferred, the Overrun bit rises and the data transfer to RDR is aborted.

When a transfer starts, the data shifted out is the data present in the Shift Register. If no data has been written in the Transmit Data Register (TDR), the last data received is transferred. If no data has been received since the last reset, all bits are transmitted low, as the Shift Register resets at 0.

When a first data is written in TDR, it is transferred immediately in the Shift Register and the TDRE bit rises. If new data is written, it remains in TDR until a transfer occurs, i.e. NSS falls and there is a valid clock on the SPCK pin. When the transfer occurs, the last data written in TDR is transferred in the Shift Register and the TDRE bit rises. This enables frequent updates of critical variables with single transfers.

Then, a new data is loaded in the Shift Register from the Transmit Data Register. In case no character is ready to be transmitted, i.e. no character has been written in TDR since the last load from TDR to the Shift Register, the Shift Register is not modified and the last received character is retransmitted.

Figure 23-9 shows a block diagram of the SPI when operating in Slave Mode.

**Figure 23-9.** Slave Mode Functional Block Diagram

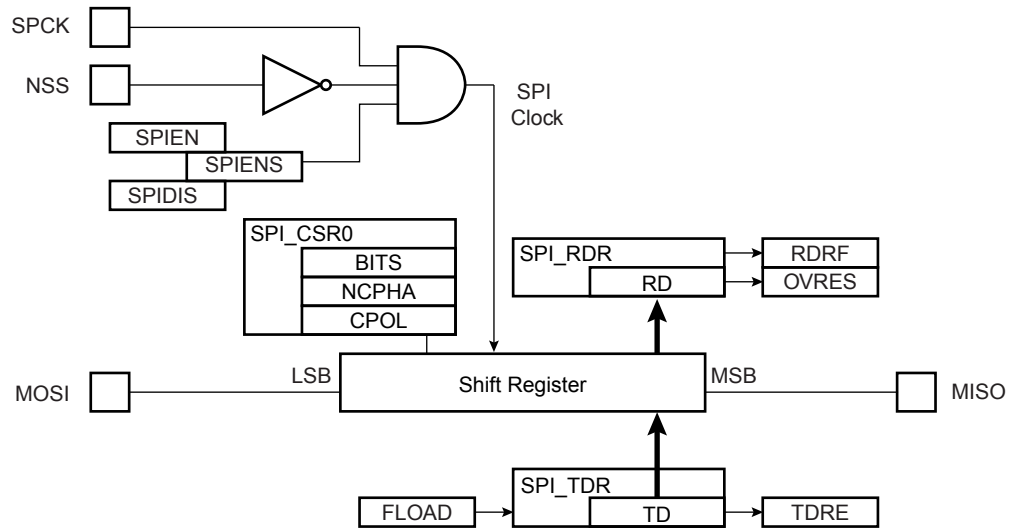

## 23.8 Serial Peripheral Interface (SPI) User Interface

**Table 23-3.** SPI Register Mapping

Offset	Register	Register Name	Access	Reset
0x00	Control Register	CR	Write-only	---
0x04	Mode Register	MR	Read/Write	0x0
0x08	Receive Data Register	RDR	Read-only	0x0
0x0C	Transmit Data Register	TDR	Write-only	---
0x10	Status Register	SR	Read-only	0x000000F0
0x14	Interrupt Enable Register	IER	Write-only	---
0x18	Interrupt Disable Register	IDR	Write-only	---
0x1C	Interrupt Mask Register	IMR	Read-only	0x0
0x20 - 0x2C	Reserved			
0x30	Chip Select Register 0	CSR0	Read/Write	0x0
0x34	Chip Select Register 1	CSR1	Read/Write	0x0
0x38	Chip Select Register 2	CSR2	Read/Write	0x0
0x3C	Chip Select Register 3	CSR3	Read/Write	0x0

## 23.8.1 SPI Control Register

**Name:** CR  
**Access Type:** Write-only

31	30	29	28	27	26	25	24
–	–	–	–	–	–	–	LASTXFER
23	22	21	20	19	18	17	16
–	–	–	–	–	–	–	–
15	14	13	12	11	10	9	8
–	–	–	–	–	–	–	–
7	6	5	4	3	2	1	0
SWRST	–	–	–	–	–	SPIDIS	SPIEN

- **SPIEN: SPI Enable**

0 = No effect.

1 = Enables the SPI to transfer and receive data.

- **SPIDIS: SPI Disable**

0 = No effect.

1 = Disables the SPI.

As soon as SPDIS is set, SPI finishes its transfer.

All pins are set in input mode and no data is received or transmitted.

If a transfer is in progress, the transfer is finished before the SPI is disabled.

If both SPIEN and SPIDIS are equal to one when the control register is written, the SPI is disabled.

- **SWRST: SPI Software Reset**

0 = No effect.

1 = Reset the SPI. A software-triggered hardware reset of the SPI interface is performed.

The SPI is in slave mode after a software reset.

PDC channels are not affected by software reset.

- **LASTXFER: Last Transfer**

0 = No effect.

1 = The current NPCS will be deasserted after the character written in TD has been transferred. When CSAAT is set, this allows to close the communication with the current serial peripheral by raising the corresponding NPCS line as soon as TD transfer has completed.

## 23.8.2 SPI Mode Register

**Name:** MR  
**Access Type:** Read/Write

31	30	29	28	27	26	25	24
DLYBCS							
23	22	21	20	19	18	17	16
–	–	–	–	PCS			
15	14	13	12	11	10	9	8
–	–	–	–	–	–	–	–
7	6	5	4	3	2	1	0
LLB	–	–	MODFDIS	FDIV	PCSDEC	PS	MSTR

- **MSTR: Master/Slave Mode**

0 = SPI is in Slave mode.

1 = SPI is in Master mode.

- **PS: Peripheral Select**

0 = Fixed Peripheral Select.

1 = Variable Peripheral Select.

- **PCSDEC: Chip Select Decode**

0 = The chip selects are directly connected to a peripheral device.

1 = The four chip select lines are connected to a 4- to 16-bit decoder.

When PCSDEC equals one, up to 15 Chip Select signals can be generated with the four lines using an external 4- to 16-bit decoder. The Chip Select Registers define the characteristics of the 15 chip selects according to the following rules:

CSR0 defines peripheral chip select signals 0 to 3.

CSR1 defines peripheral chip select signals 4 to 7.

CSR2 defines peripheral chip select signals 8 to 11.

CSR3 defines peripheral chip select signals 12 to 14.

- **FDIV: Clock Selection**

0 = The SPI operates at MCK.

1 = The SPI operates at MCK/32.

- **MODFDIS: Mode Fault Detection**

0 = Mode fault detection is enabled.

1 = Mode fault detection is disabled.

- **LLB: Local Loopback Enable**

0 = Local loopback path disabled.

1 = Local loopback path enabled.

LLB controls the local loopback on the data serializer for testing in Master Mode only. MISO is internally connected to MOSI.



- **PCS: Peripheral Chip Select**

This field is only used if Fixed Peripheral Select is active (PS = 0).

If PCSDEC = 0:

PCS = xxx0	NPCS[3:0] = 1110
PCS = xx01	NPCS[3:0] = 1101
PCS = x011	NPCS[3:0] = 1011
PCS = 0111	NPCS[3:0] = 0111
PCS = 1111	forbidden (no peripheral is selected)

(x = don't care)

If PCSDEC = 1:

NPCS[3:0] output signals = PCS.

- **DLYBCS: Delay Between Chip Selects**

This field defines the delay from NPCS inactive to the activation of another NPCS. The DLYBCS time guarantees non-overlapping chip selects and solves bus contentions in case of peripherals having long data float times.

If DLYBCS is less than or equal to six, six MCK periods (or 6\*N MCK periods if FDIV is set) will be inserted by default.

Otherwise, the following equation determines the delay:

If FDIV is 0:

$$\text{Delay Between Chip Selects} = \frac{DLYBCS}{MCK}$$

If FDIV is 1:

$$\text{Delay Between Chip Selects} = \frac{DLYBCS \times N}{MCK}$$

## 23.8.3 SPI Receive Data Register

**Name:** RDR

**Access Type:** Read-only

31	30	29	28	27	26	25	24
–	–	–	–	–	–	–	–
23	22	21	20	19	18	17	16
–	–	–	–	PCS			
15	14	13	12	11	10	9	8
RD							
7	6	5	4	3	2	1	0
RD							

- **RD: Receive Data**

Data received by the SPI Interface is stored in this register right-justified. Unused bits read zero.

- **PCS: Peripheral Chip Select**

In Master Mode only, these bits indicate the value on the NPCS pins at the end of a transfer. Otherwise, these bits read zero.

## 23.8.4 SPI Transmit Data Register

**Name:** TDR  
**Access Type:** Write-only

31	30	29	28	27	26	25	24	
–	–	–	–	–	–	–	LASTXFER	
23	22	21	20	19	18	17	16	
–	–	–	–	PCS				–
15	14	13	12	11	10	9	8	
TD								
7	6	5	4	3	2	1	0	
TD								

• **TD: Transmit Data**

Data to be transmitted by the SPI Interface is stored in this register. Information to be transmitted must be written to the transmit data register in a right-justified format.

PCS: Peripheral Chip Select

This field is only used if Variable Peripheral Select is active (PS = 1).

If PCSDEC = 0:

PCS = xxx0	NPCS[3:0] = 1110
PCS = xx01	NPCS[3:0] = 1101
PCS = x011	NPCS[3:0] = 1011
PCS = 0111	NPCS[3:0] = 0111
PCS = 1111	forbidden (no peripheral is selected)

(x = don't care)

If PCSDEC = 1:

NPCS[3:0] output signals = PCS

• **LASTXFER: Last Transfer**

0 = No effect.

1 = The current NPCS will be deasserted after the character written in TD has been transferred. When CSAAT is set, this allows to close the communication with the current serial peripheral by raising the corresponding NPCS line as soon as TD transfer has completed.

This field is only used if Variable Peripheral Select is active (PS = 1).

## 23.8.5 SPI Status Register

**Name:** SR

**Access Type:** Read-only

31	30	29	28	27	26	25	24
–	–	–	–	–	–	–	–
23	22	21	20	19	18	17	16
–	–	–	–	–	–	–	SPIENS
15	14	13	12	11	10	9	8
–	–	–	–	–	–	TXEMPTY	NSSR
7	6	5	4	3	2	1	0
TXBUFE	RXBUFF	ENDTX	ENDRX	OVRES	MODF	TDRE	RDRF

- **RDRF: Receive Data Register Full**

0 = No data has been received since the last read of RDR

1 = Data has been received and the received data has been transferred from the serializer to RDR since the last read of RDR.

- **TDRE: Transmit Data Register Empty**

0 = Data has been written to TDR and not yet transferred to the serializer.

1 = The last data written in the Transmit Data Register has been transferred to the serializer.

TDRE equals zero when the SPI is disabled or at reset. The SPI enable command sets this bit to one.

- **MODF: Mode Fault Error**

0 = No Mode Fault has been detected since the last read of SR.

1 = A Mode Fault occurred since the last read of the SR.

- **OVRES: Overrun Error Status**

0 = No overrun has been detected since the last read of SR.

1 = An overrun has occurred since the last read of SR.

An overrun occurs when RDR is loaded at least twice from the serializer since the last read of the RDR.

- **ENDRX: End of RX buffer**

0 = The Receive Counter Register has not reached 0 since the last write in RCR or RNCR.

1 = The Receive Counter Register has reached 0 since the last write in RCR or RNCR.

- **ENDTX: End of TX buffer**

0 = The Transmit Counter Register has not reached 0 since the last write in TCR or TNCR.

1 = The Transmit Counter Register has reached 0 since the last write in TCR or TNCR.

- **RXBUFF: RX Buffer Full**

0 = RCR or RNCR has a value other than 0.

1 = Both RCR and RNCR has a value of 0.

- **TXBUFE: TX Buffer Empty**

0 = TCR or TNCR has a value other than 0.

1 = Both TCR and TNCR has a value of 0.

- **NSSR: NSS Rising**

0 = No rising edge detected on NSS pin since last read.

1 = A rising edge occurred on NSS pin since last read.

- **TXEMPTY: Transmission Registers Empty**

0 = As soon as data is written in TDR.

1 = TDR and internal shifter are empty. If a transfer delay has been defined, TXEMPTY is set after the completion of such delay.

- **SPIENS: SPI Enable Status**

0 = SPI is disabled.

1 = SPI is enabled.

## 23.8.6 SPI Interrupt Enable Register

**Name:** IER

**Access Type:** Write-only

31	30	29	28	27	26	25	24
–	–	–	–	–	–	–	–
23	22	21	20	19	18	17	16
–	–	–	–	–	–	–	–
15	14	13	12	11	10	9	8
–	–	–	–	–	–	TXEMPTY	NSSR
7	6	5	4	3	2	1	0
TXBUFE	RXBUFF	ENDTX	ENDRX	OVRES	MODF	TDRE	RDRF

- **RDRF: Receive Data Register Full Interrupt Enable**
- **TDRE: SPI Transmit Data Register Empty Interrupt Enable**
- **MODF: Mode Fault Error Interrupt Enable**
- **OVRES: Overrun Error Interrupt Enable**
- **ENDRX: End of Receive Buffer Interrupt Enable**
- **ENDTX: End of Transmit Buffer Interrupt Enable**
- **RXBUFF: Receive Buffer Full Interrupt Enable**
- **TXBUFE: Transmit Buffer Empty Interrupt Enable**
- **TXEMPTY: Transmission Registers Empty Enable**
- **NSSR: NSS Rising Interrupt Enable**

0 = No effect.

1 = Enables the corresponding interrupt.

## 23.8.7 SPI Interrupt Disable Register

**Name:** IDR

**Access Type:** Write-only

31	30	29	28	27	26	25	24
–	–	–	–	–	–	–	–
23	22	21	20	19	18	17	16
–	–	–	–	–	–	–	–
15	14	13	12	11	10	9	8
–	–	–	–	–	–	TXEMPTY	NSSR
7	6	5	4	3	2	1	0
TXBUFE	RXBUFF	ENDTX	ENDRX	OVRES	MODF	TDRE	RDRF

- **RDRF: Receive Data Register Full Interrupt Disable**
- **TDRE: SPI Transmit Data Register Empty Interrupt Disable**
- **MODF: Mode Fault Error Interrupt Disable**
- **OVRES: Overrun Error Interrupt Disable**
- **ENDRX: End of Receive Buffer Interrupt Disable**
- **ENDTX: End of Transmit Buffer Interrupt Disable**
- **RXBUFF: Receive Buffer Full Interrupt Disable**
- **TXBUFE: Transmit Buffer Empty Interrupt Disable**
- **TXEMPTY: Transmission Registers Empty Disable**
- **NSSR: NSS Rising Interrupt Disable**

0 = No effect.

1 = Disables the corresponding interrupt.

## 23.8.8 SPI Interrupt Mask Register

**Name:** IMR

**Access Type:** Read-only

31	30	29	28	27	26	25	24
–	–	–	–	–	–	–	–
23	22	21	20	19	18	17	16
–	–	–	–	–	–	–	–
15	14	13	12	11	10	9	8
–	–	–	–	–	–	TXEMPTY	NSSR
7	6	5	4	3	2	1	0
TXBUFE	RXBUFF	ENDTX	ENDRX	OVRES	MODF	TDRE	RDRF

- **RDRF: Receive Data Register Full Interrupt Mask**
- **TDRE: SPI Transmit Data Register Empty Interrupt Mask**
- **MODF: Mode Fault Error Interrupt Mask**
- **OVRES: Overrun Error Interrupt Mask**
- **ENDRX: End of Receive Buffer Interrupt Mask**
- **ENDTX: End of Transmit Buffer Interrupt Mask**
- **RXBUFF: Receive Buffer Full Interrupt Mask**
- **TXBUFE: Transmit Buffer Empty Interrupt Mask**
- **TXEMPTY: Transmission Registers Empty Mask**
- **NSSR: NSS Rising Interrupt Mask**

0 = The corresponding interrupt is not enabled.

1 = The corresponding interrupt is enabled.



## 23.8.9 SPI Chip Select Register

**Name:** CSR0... CSR3

**Access Type:** Read/Write

31	30	29	28	27	26	25	24
DLYBCT							
23	22	21	20	19	18	17	16
DLYBS							
15	14	13	12	11	10	9	8
SCBR							
7	6	5	4	3	2	1	0
BITS				CSAAT	CSNAAT	NCPHA	CPOL

- **CPOL: Clock Polarity**

0 = The inactive state value of SPCK is logic level zero.

1 = The inactive state value of SPCK is logic level one.

CPOL is used to determine the inactive state value of the serial clock (SPCK). It is used with NCPHA to produce the required clock/data relationship between master and slave devices.

- **NCPHA: Clock Phase**

0 = Data is changed on the leading edge of SPCK and captured on the following edge of SPCK.

1 = Data is captured on the leading edge of SPCK and changed on the following edge of SPCK.

NCPHA determines which edge of SPCK causes data to change and which edge causes data to be captured. NCPHA is used with CPOL to produce the required clock/data relationship between master and slave devices.

- **CSNAAT: Chip Select Not Active After Transfer**

0 = The Peripheral Chip Select Line rises as soon as the last transfer is achieved

1 = The Peripheral Chip Select Line rises after every transfer

CSNAAT can be used to force the Peripheral Chip Select Line to go inactive after every transfer. This allows successful interfacing to SPI slave devices that require this behavior.

- **CSAAT: Chip Select Active After Transfer**

0 = The Peripheral Chip Select Line rises as soon as the last transfer is achieved.

1 = The Peripheral Chip Select does not rise after the last transfer is achieved. It remains active until a new transfer is requested on a different chip select.

- **BITS: Bits Per Transfer**

The BITS field determines the number of data bits transferred. Reserved values should not be used, see [Table 23-4 on page 218](#).

**Table 23-4.** BITS, Bits Per Transfer

BITS	Bits Per Transfer
0000	8
0001	9
0010	10
0011	11
0100	12
0101	13
0110	14
0111	15
1000	16
1001	Reserved
1010	Reserved
1011	Reserved
1100	Reserved
1101	Reserved
1110	Reserved
1111	Reserved

• **SCBR: Serial Clock Baud Rate**

In Master Mode, the SPI Interface uses a modulus counter to derive the SPCK baud rate from the Master Clock MCK. The Baud rate is selected by writing a value from 1 to 255 in the SCBR field. The following equations determine the SPCK baud rate:

If FDIV is 0:

$$\text{SPCK Baudrate} = \frac{MCK}{SCBR}$$

If FDIV is 1:

$$\text{SPCK Baudrate} = \frac{MCK}{(N \times SCBR)}$$

Note: N = 32

Programming the SCBR field at 0 is forbidden. Triggering a transfer while SCBR is at 0 can lead to unpredictable results. At reset, SCBR is 0 and the user has to program it at a valid value before performing the first transfer.

• **DLYBS: Delay Before SPCK**

This field defines the delay from NPCS valid to the first valid SPCK transition.

When DLYBS equals zero, the NPCS valid to SPCK transition is 1/2 the SPCK clock period.



Otherwise, the following equations determine the delay:

If FDIV is 0:

$$\text{Delay Before SPCK} = \frac{DLYBS}{MCK}$$

If FDIV is 1:

$$\text{Delay Before SPCK} = \frac{N \times DLYBS}{MCK}$$

Note: N = 32

- **DLYBCT: Delay Between Consecutive Transfers**

This field defines the delay between two consecutive transfers with the same peripheral without removing the chip select. The delay is always inserted after each transfer and before removing the chip select if needed.

When DLYBCT equals zero, no delay between consecutive transfers is inserted and the clock keeps its duty cycle over the character transfers.

Otherwise, the following equation determines the delay:

If FDIV is 0:

$$\text{Delay Between Consecutive Transfers} = \frac{32 \times DLYBCT}{MCK} + \frac{SCBR}{2MCK}$$

If FDIV is 1:

$$\text{Delay Between Consecutive Transfers} = \frac{32 \times N \times DLYBCT}{MCK} + \frac{N \times SCBR}{2MCK}$$

N = 32

## 24. Two-Wire Interface (TWI)

2.1.1.0

### 24.1 Features

- **Compatible with Atmel Two-wire Interface Serial Memory and I<sup>2</sup>C Compatible Devices<sup>(1)</sup>**
- **One, Two or Three Bytes for Slave Address**
- **Sequential Read-write Operations**
- **Master, Multi-master and Slave Mode Operation**
- **Bit Rate: Up to 400 Kbits**
- **General Call Supported in Slave mode**
- **Connection to Peripheral DMA Controller (PDC) Channel Capabilities Optimizes Data Transfers in Master Mode Only**
  - **One Channel for the Receiver, One Channel for the Transmitter**
  - **Next Buffer Support**

Note: 1. See [Table 24-1](#) below for details on compatibility with I<sup>2</sup>C Standard.

### 24.2 Overview

The Atmel Two-wire Interface (TWI) interconnects components on a unique two-wire bus, made up of one clock line and one data line with speeds of up to 400 Kbits per second, based on a byte-oriented transfer format. It can be used with any Atmel Two-wire Interface bus Serial EEPROM and I<sup>2</sup>C compatible device such as Real Time Clock (RTC), Dot Matrix/Graphic LCD Controllers and Temperature Sensor, to name but a few. The TWI is programmable as a master or a slave with sequential or single-byte access. Multiple master capability is supported. Arbitration of the bus is performed internally and puts the TWI in slave mode automatically if the bus arbitration is lost.

A configurable baud rate generator permits the output data rate to be adapted to a wide range of core clock frequencies.

Below, [Table 24-1](#) lists the compatibility level of the Atmel Two-wire Interface in Master Mode and a full I<sup>2</sup>C compatible device.

**Table 24-1.** Atmel TWI compatibility with I<sup>2</sup>C Standard

I <sup>2</sup> C Standard	Atmel TWI
Standard Mode Speed (100 KHz)	Supported
Fast Mode Speed (400 KHz)	Supported
7 or 10 bits Slave Addressing	Supported
START BYTE <sup>(1)</sup>	Not Supported
Repeated Start (Sr) Condition	Supported
ACK and NACK Management	Supported
Slope control and input filtering (Fast mode)	Not Supported
Clock stretching	Supported

Note: 1. START + b000000001 + Ack + Sr

### 24.3 List of Abbreviations

**Table 24-2.** Abbreviations

Abbreviation	Description
TWI	Two-wire Interface
A	Acknowledge
NA	Non Acknowledge
P	Stop
S	Start
Sr	Repeated Start
SADR	Slave Address
ADR	Any address except SADR
R	Read
W	Write

### 24.4 Block Diagram

**Figure 24-1.** Block Diagram

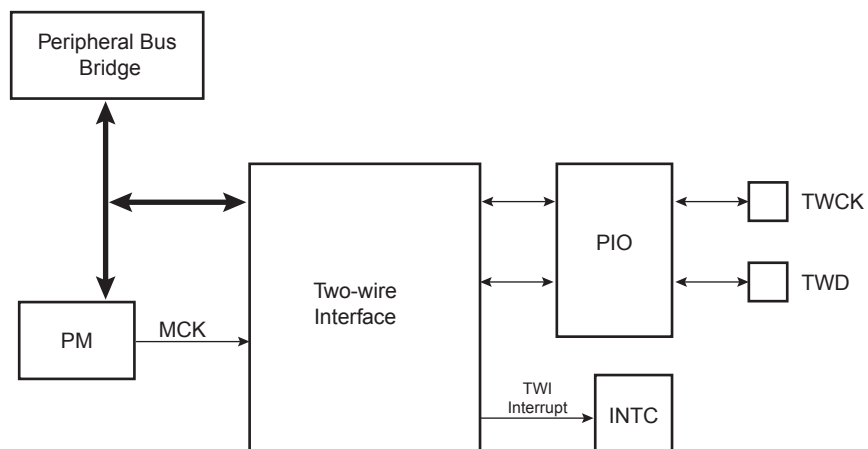

## 24.5 Application Block Diagram

Figure 24-2. Application Block Diagram

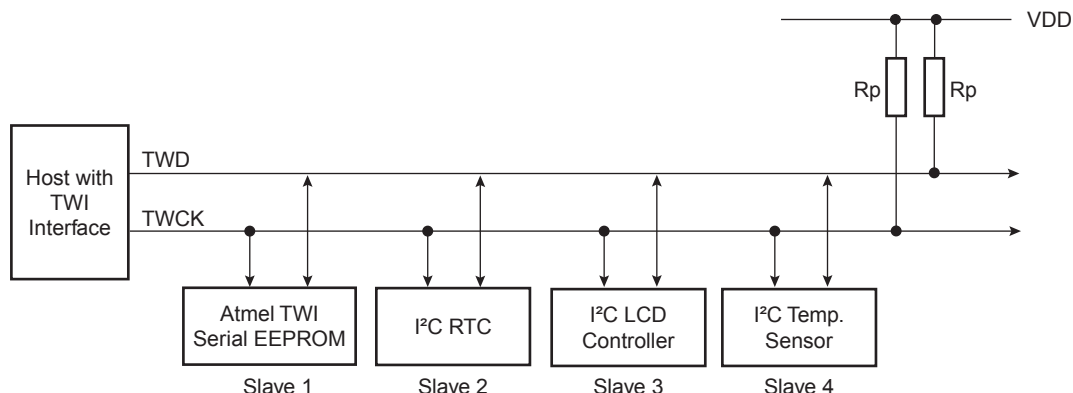

Rp: Pull up value as given by the I²C Standard

## 24.6 I/O Lines Description

Table 24-3. I/O Lines Description

Pin Name	Pin Description	Type
TWD	Two-wire Serial Data	Input/Output
TWCK	Two-wire Serial Clock	Input/Output

## 24.7 Product Dependencies

### 24.7.1 I/O Lines

Both TWD and TWCK are bidirectional lines, connected to a positive supply voltage via a current source or pull-up resistor (see [Figure 24-2 on page 222](#)). When the bus is free, both lines are high. The output stages of devices connected to the bus must have an open-drain or open-collector to perform the wired-AND function.

TWD and TWCK pins may be multiplexed with GPIO lines. To enable the TWI, the programmer must perform the following steps:

- Program the GPIO controller to:
  - Dedicate TWD and TWCK as peripheral lines.
  - Define TWD and TWCK as open-drain.

### 24.7.2 Power Management

The TWI clock is generated by the Power Manager (PM). Before using the TWI, the programmer must ensure that the TWI clock is enabled in the PM.

In the TWI description, Master Clock (MCK) is the clock of the peripheral bus to which the TWI is connected.

## 24.7.3 Interrupt

The TWI interface has an interrupt line connected to the Interrupt Controller (INTC). In order to handle interrupts, the INTC must be programmed before configuring the TWI.

## 24.8 Functional Description

### 24.8.1 Transfer Format

The data put on the TWD line must be 8 bits long. Data is transferred MSB first; each byte must be followed by an acknowledgement. The number of bytes per transfer is unlimited (see [Figure 24-4](#)).

Each transfer begins with a START condition and terminates with a STOP condition (see [Figure 24-3](#)).

- A high-to-low transition on the TWD line while TWCK is high defines the START condition.
- A low-to-high transition on the TWD line while TWCK is high defines a STOP condition.

**Figure 24-3.** START and STOP Conditions

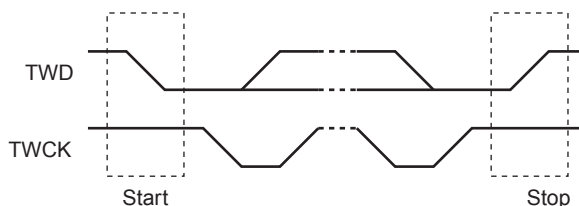

**Figure 24-4.** Transfer Format

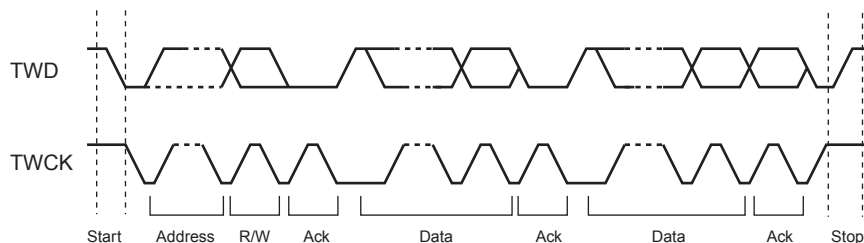

## 24.9 Modes of Operation

The TWI has six modes of operations:

- Master transmitter mode
- Master receiver mode
- Multi-master transmitter mode
- Multi-master receiver mode
- Slave transmitter mode
- Slave receiver mode

These modes are described in the following chapters.

## 24.10 Master Mode

### 24.10.1 Definition

The Master is the device which starts a transfer, generates a clock and stops it.

### 24.10.2 Application Block Diagram

Figure 24-5. Master Mode Typical Application Block Diagram

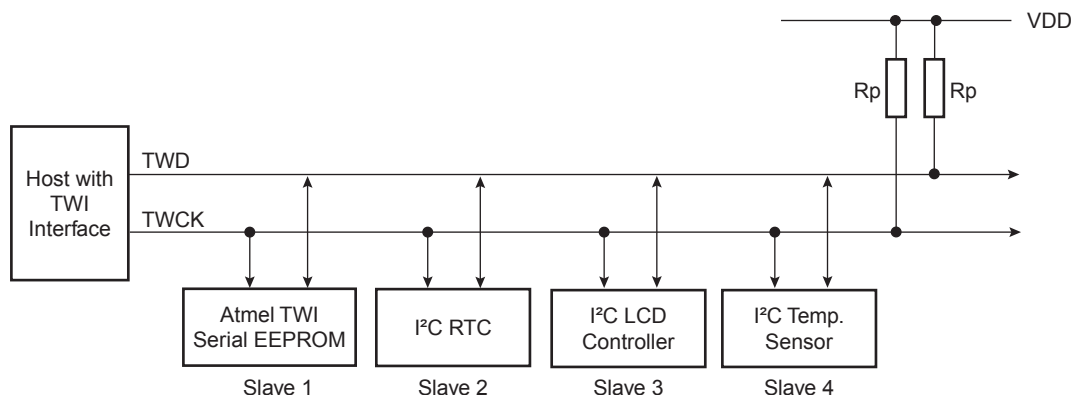

Rp: Pull up value as given by the I²C Standard

### 24.10.3 Programming Master Mode

The following registers have to be programmed before entering Master mode:

1. DADR (+ IADRSZ + IADR if a 10 bit device is addressed): The device address is used to access slave devices in read or write mode.
2. CKDIV + CHDIV + CLDIV: Clock Waveform.
3. SVDIS: Disable the slave mode.
4. MSEN: Enable the master mode.

### 24.10.4 Master Transmitter Mode

After the master initiates a Start condition when writing into the Transmit Holding Register, THR, it sends a 7-bit slave address, configured in the Master Mode register (DADR in MMR), to notify the slave device. The bit following the slave address indicates the transfer direction, 0 in this case (MREAD = 0 in MMR).

The TWI transfers require the slave to acknowledge each received byte. During the acknowledge clock pulse (9th pulse), the master releases the data line (HIGH), enabling the slave to pull it down in order to generate the acknowledge. The master polls the data line during this clock pulse and sets the NACK in the status register if the slave does not acknowledge the byte. As with the other status bits, an interrupt can be generated if enabled in the interrupt enable register (IER). If the slave acknowledges the byte, the data written in the THR, is then shifted in the internal shifter and transferred. When an acknowledge is detected, the TXRDY bit is set until a new write in the THR. When no more data is written into the THR, the master generates a stop condition to end the transfer. The end of the complete transfer is marked by the TXCOMP bit set to one. See [Figure 24-6](#), [Figure 24-7](#), and [Figure 24-8](#) on page 225.

TXRDY is used as Transmit Ready for the PDC transmit channel.



**Figure 24-6. Master Write with One Data Byte**

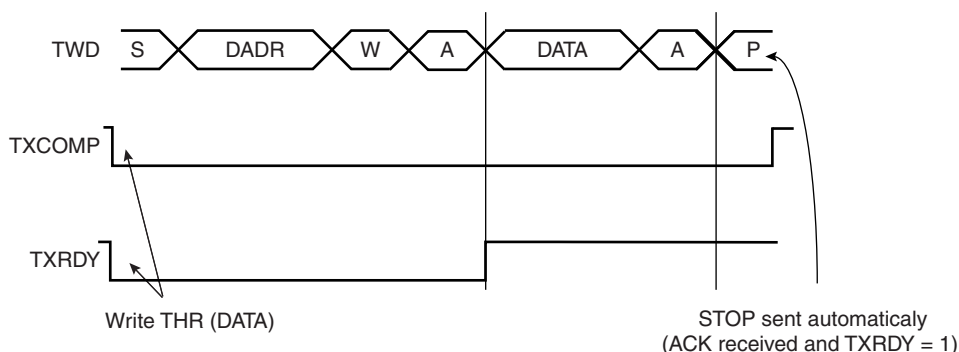

**Figure 24-7. Master Write with Multiple Data Byte**

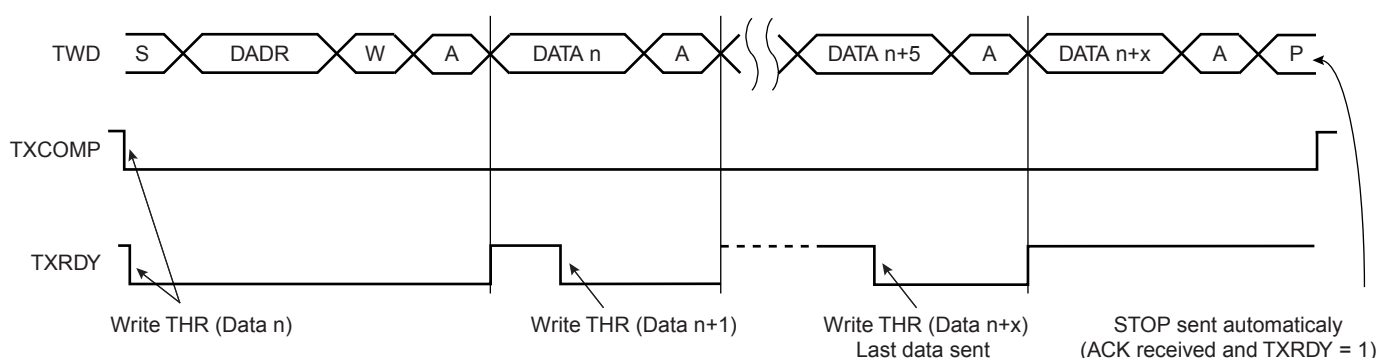

**Figure 24-8. Master Write with One Byte Internal Address and Multiple Data Bytes**

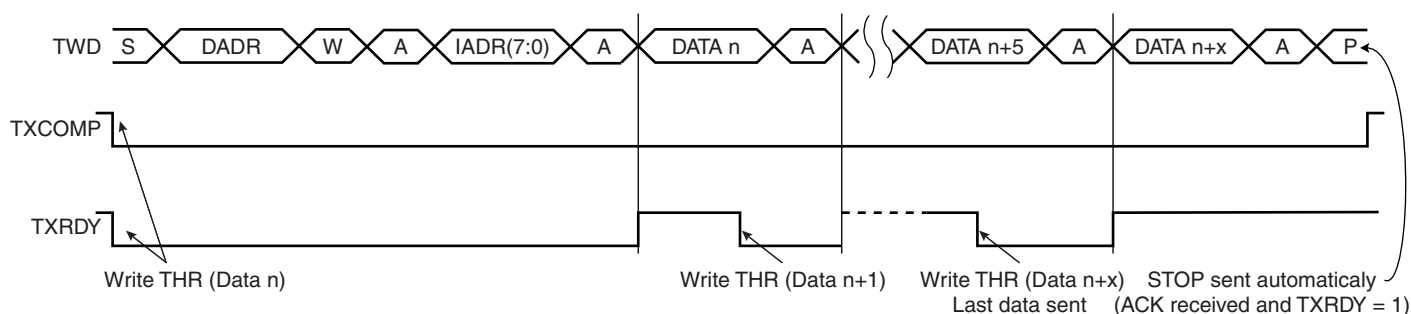

## 24.10.5 Master Receiver Mode

The read sequence begins by setting the START bit. After the start condition has been sent, the master sends a 7-bit slave address to notify the slave device. The bit following the slave address indicates the transfer direction, 1 in this case (MREAD = 1 in MMR). During the acknowledge clock pulse (9th pulse), the master releases the data line (HIGH), enabling the slave to pull it down in order to generate the acknowledge. The master polls the data line during this clock pulse and sets the NACK bit in the status register if the slave does not acknowledge the byte.

If an acknowledge is received, the master is then ready to receive data from the slave. After data has been received, the master sends an acknowledge condition to notify the slave that the data has been received except for the last data, after the stop condition. See [Figure 24-9](#). When the

RXRDY bit is set in the status register, a character has been received in the receive-holding register (RHR). The RXRDY bit is reset when reading the RHR.

When a single data byte read is performed, with or without internal address (IADR), the START and STOP bits must be set at the same time. See Figure 24-9. When a multiple data byte read is performed, with or without IADR, the STOP bit must be set after the next-to-last data received. See Figure 24-10. For Internal Address usage see "Internal Address" on page 226.

**Figure 24-9.** Master Read with One Data Byte

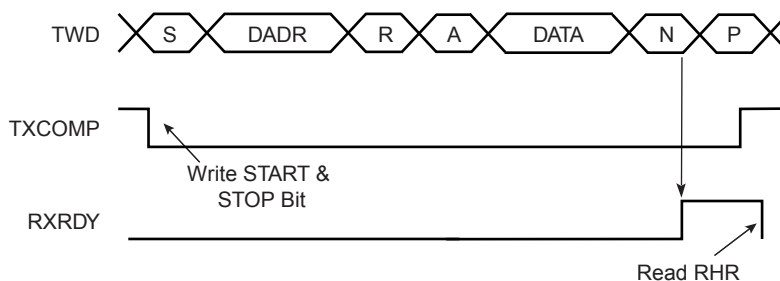

**Figure 24-10.** Master Read with Multiple Data Bytes

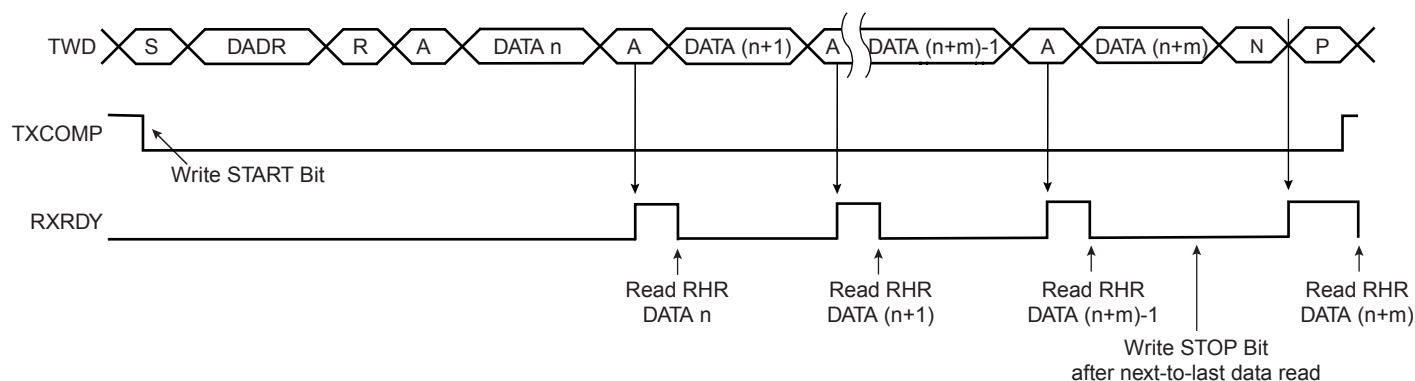

RXRDY is used as Receive Ready for the PDC receive channel.

## 24.10.6 Internal Address

The TWI interface can perform various transfer formats: Transfers with 7-bit slave address devices and 10-bit slave address devices.

### 24.10.6.1 7-bit Slave Addressing

When Addressing 7-bit slave devices, the internal address bytes are used to perform random address (read or write) accesses to reach one or more data bytes, within a memory page location in a serial memory, for example. When performing read operations with an internal address, the TWI performs a write operation to set the internal address into the slave device, and then switch to Master Receiver mode. Note that the second start condition (after sending the IADR) is sometimes called "repeated start" (Sr) in I2C fully-compatible devices. See Figure 24-12. See Figure 24-11 and Figure 24.11 for Master Write operation with internal address.

The three internal address bytes are configurable through the Master Mode register (MMR).

If the slave device supports only a 7-bit address, i.e. no internal address, **IADRSZ** must be set to 0.

In the figures below the following abbreviations are used:

- **S** Start
- **Sr** Repeated Start
- **P** Stop
- **W** Write
- **R** Read
- **A** Acknowledge
- **N** Not Acknowledge
- **DADR** Device Address
- **IADR** Internal Address

**Figure 24-11. Master Write with One, Two or Three Bytes Internal Address and One Data Byte**

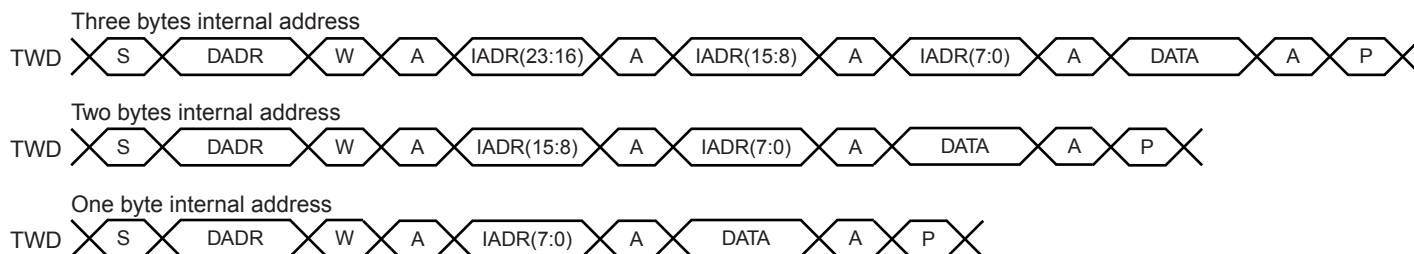

**Figure 24-12. Master Read with One, Two or Three Bytes Internal Address and One Data Byte**

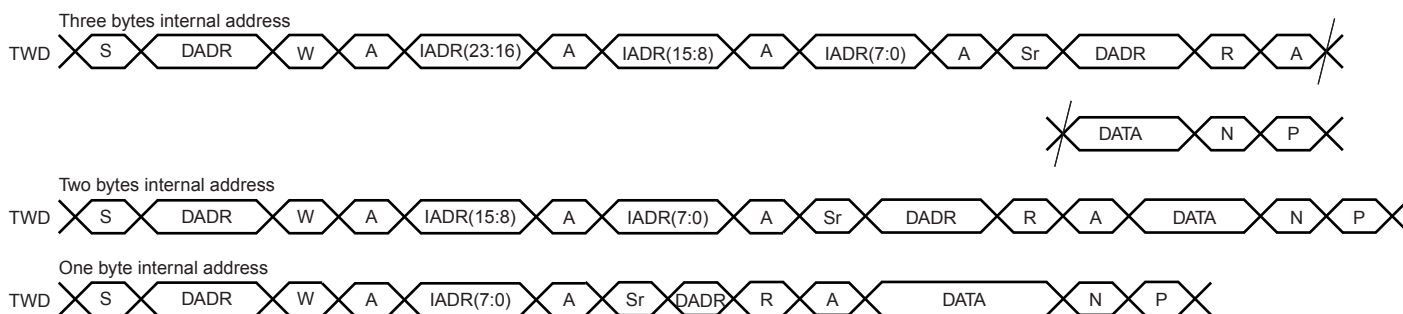

## 24.10.6.2 10-bit Slave Addressing

For a slave address higher than 7 bits, the user must configure the address size (**IADRSZ**) and set the other slave address bits in the internal address register (IADR). The two remaining Internal address bytes, IADR[15:8] and IADR[23:16] can be used the same as in 7-bit Slave Addressing.

**Example:** Address a 10-bit device:

(10-bit device address is b1 b2 b3 b4 b5 b6 b7 b8 b9 b10)

1. Program IADRSZ = 1,
2. Program DADR with 1 1 1 1 0 b1 b2 (b1 is the MSB of the 10-bit address, b2, etc.)
3. Program IADR with b3 b4 b5 b6 b7 b8 b9 b10 (b10 is the LSB of the 10-bit address)

Figure 24.11 below shows a byte write to an Atmel AT24LC512 EEPROM. This demonstrates the use of internal addresses to access the device.

## 24.11 Internal Address Usage Using the Peripheral DMA Controller (PDC)

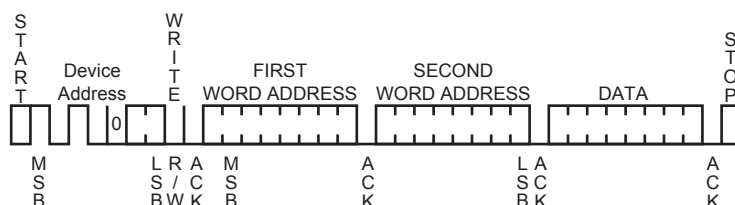

The use of the PDC significantly reduces the CPU load.

To assure correct implementation, respect the following programming sequences:

### 24.11.1 Data Transmit with the PDC

1. Initialize the transmit PDC (memory pointers, size, etc.).
2. Configure the master mode (DADR, CKDIV, etc.).
3. Start the transfer by setting the PDC TXTEN bit.
4. Wait for the PDC end TX flag.
5. Disable the PDC by setting the PDC TXDIS bit.

### 24.11.2 Data Receive with the PDC

1. Initialize the receive PDC (memory pointers, size - 1, etc.).
2. Configure the master mode (DADR, CKDIV, etc.).
3. Start the transfer by setting the PDC RXTEN bit.
4. Wait for the PDC end RX flag.
5. Disable the PDC by setting the PDC RXDIS bit.

## 24.11.3 Read-write Flowcharts

The following flowcharts shown in [Figure 24-13](#) to [Figure 24-18](#) on [page 234](#) give examples for read and write operations. A polling or interrupt method can be used to check the status bits. The interrupt method requires that the interrupt enable register (IER) be configured first.

**Figure 24-13.** TWI Write Operation with Single Data Byte without Internal Address.

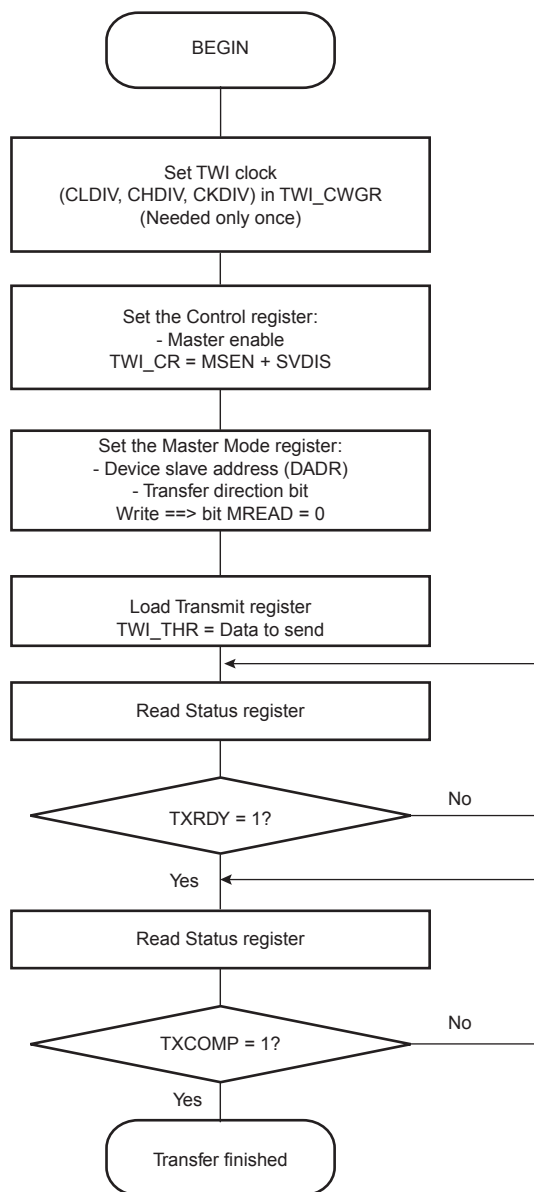

Figure 24-14. TWI Write Operation with Single Data Byte and Internal Address

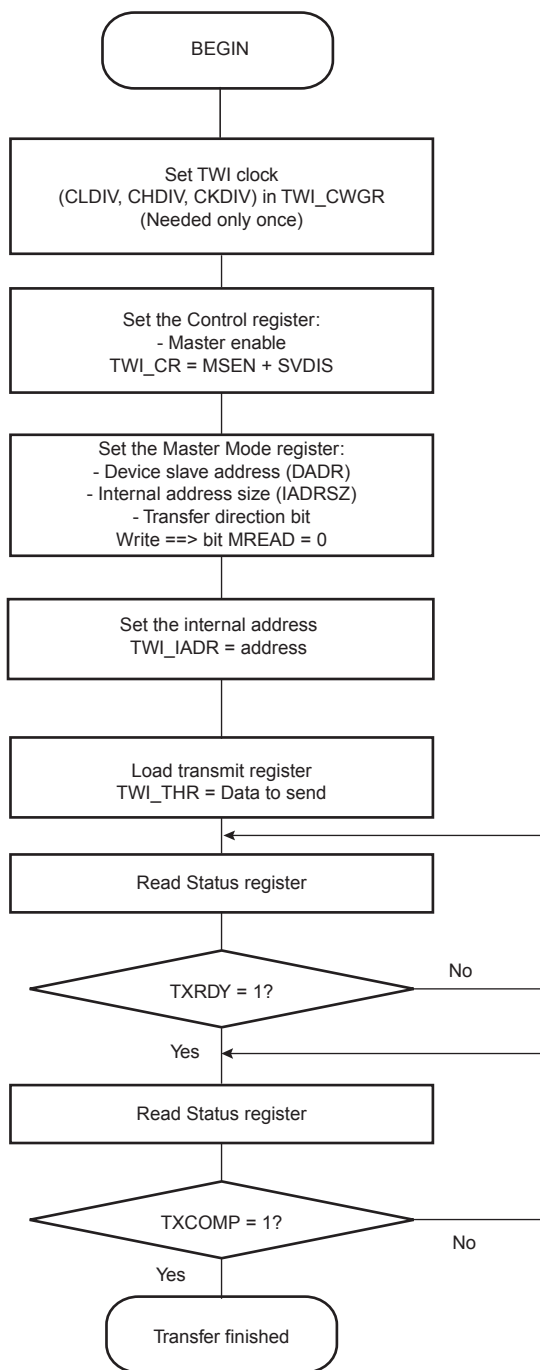

Figure 24-15. TWI Write Operation with Multiple Data Bytes with or without Internal Address

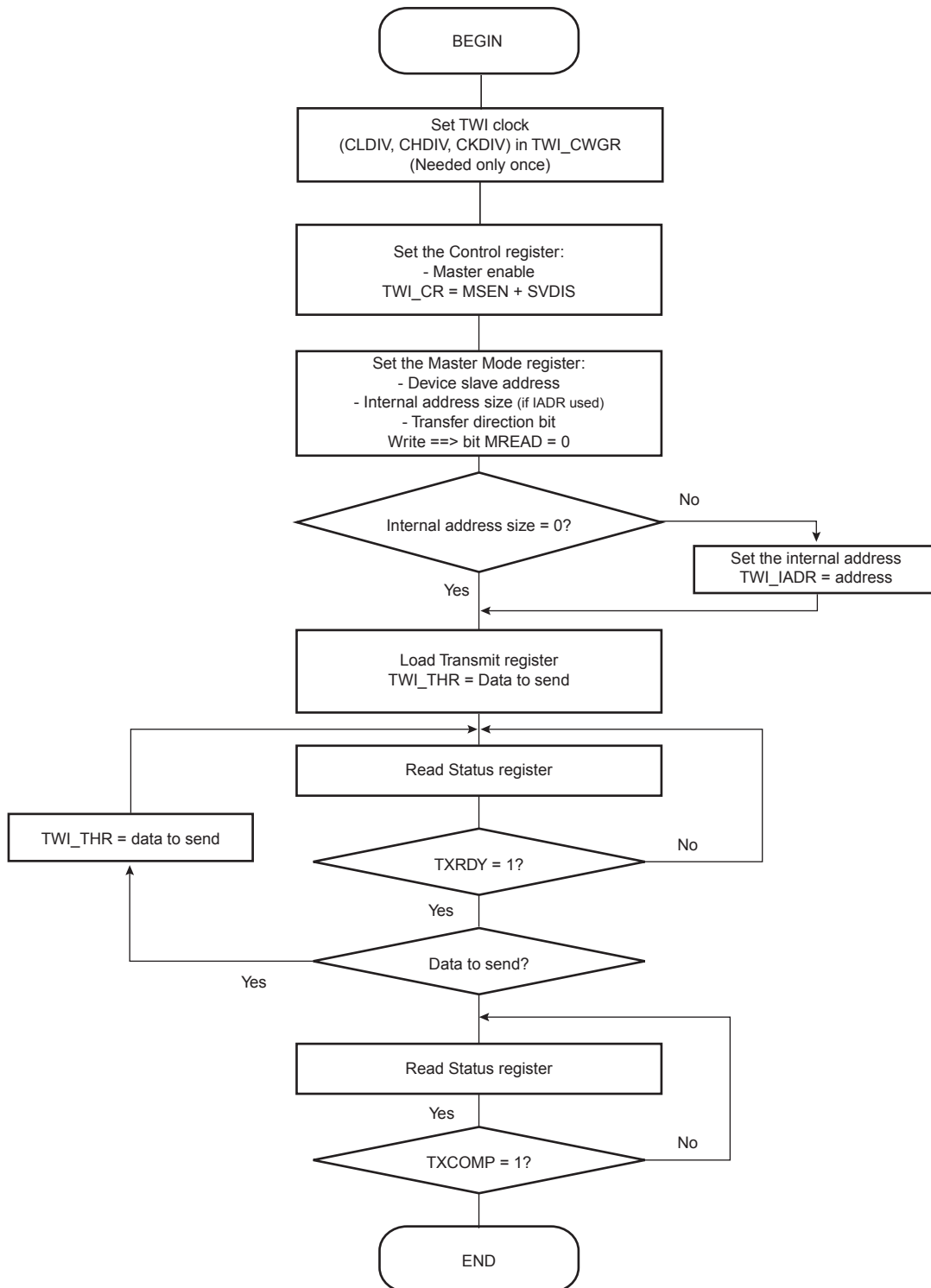

Figure 24-16. TWI Read Operation with Single Data Byte without Internal Address

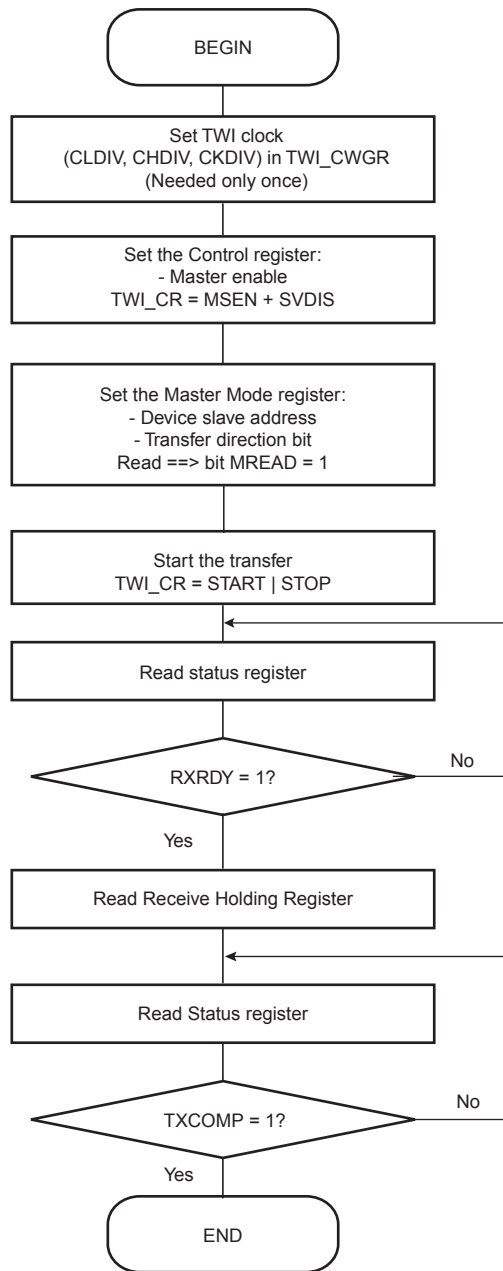
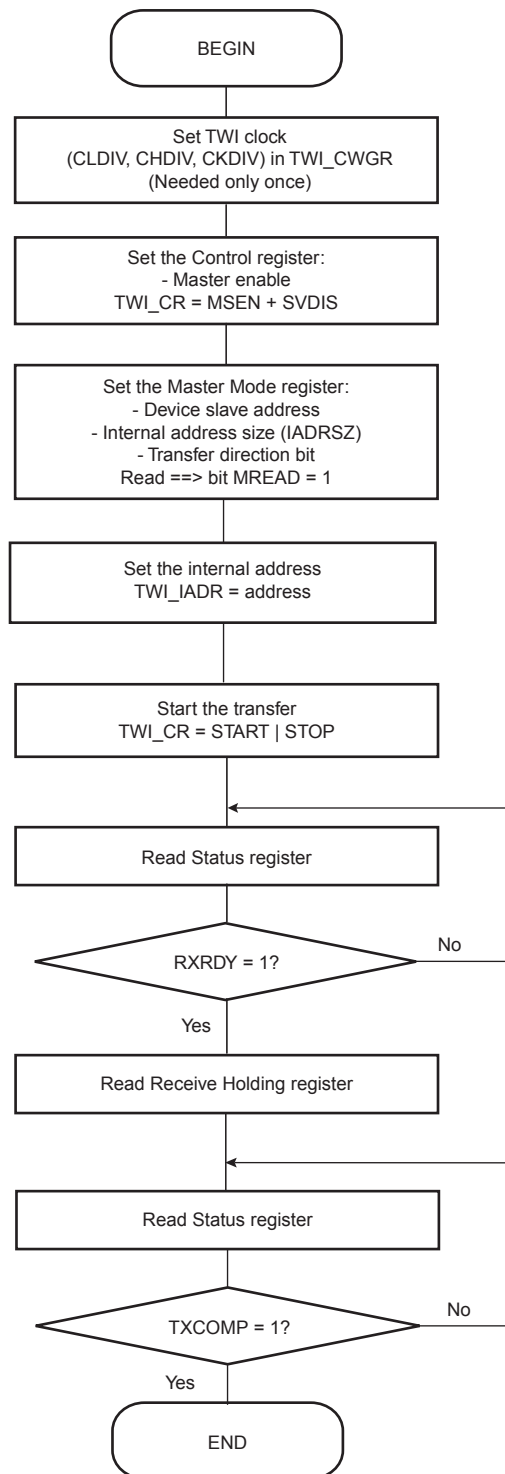
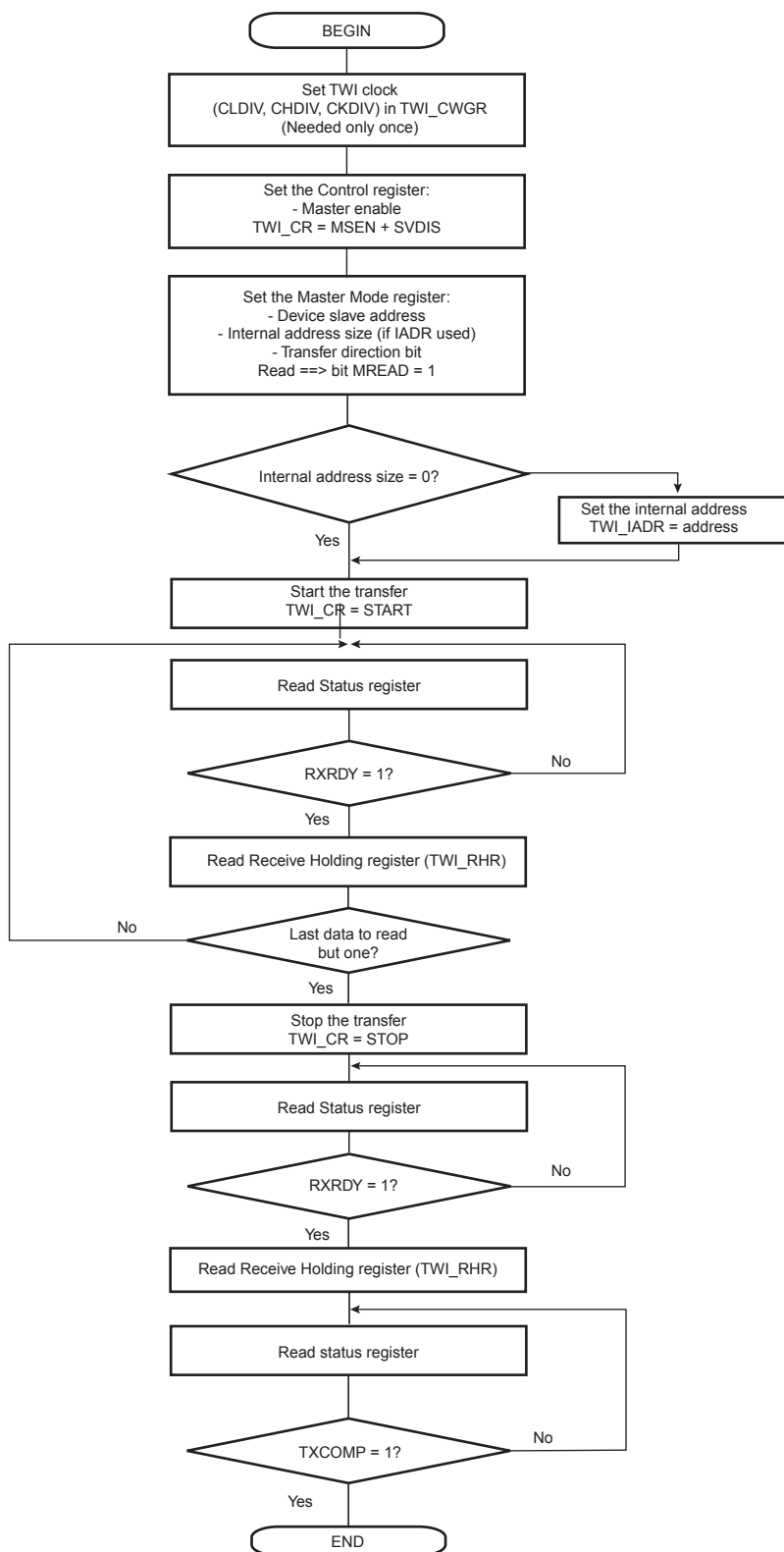



Figure 24-17. TWI Read Operation with Single Data Byte and Internal Address



**Figure 24-18.** TWI Read Operation with Multiple Data Bytes with or without Internal Address



## 24.12 Multi-master Mode

### 24.12.1 Definition

More than one master may handle the bus at the same time without data corruption by using arbitration.

Arbitration starts as soon as two or more masters place information on the bus at the same time, and stops (arbitration is lost) for the master that intends to send a logical one while the other master sends a logical zero.

As soon as arbitration is lost by a master, it stops sending data and listens to the bus in order to detect a stop. When the stop is detected, the master who has lost arbitration may put its data on the bus by respecting arbitration.

Arbitration is illustrated in [Figure 24-20 on page 236](#).

### 24.12.2 Different Multi-master Modes

Two multi-master modes may be distinguished:

1. TWI is considered as a Master only and will never be addressed.
2. TWI may be either a Master or a Slave and may be addressed.

Note: Arbitration is supported in both Multi-master modes.

#### 24.12.2.1 TWI as Master Only

In this mode, TWI is considered as a Master only (MSEN is always at one) and must be driven like a Master with the ARBLST (ARBitration Lost) flag in addition.

If arbitration is lost (ARBLST = 1), the programmer must reinitiate the data transfer.

If the user starts a transfer (ex.: DADR + START + W + Write in THR) and if the bus is busy, the TWI automatically waits for a STOP condition on the bus to initiate the transfer (see [Figure 24-19 on page 236](#)).

Note: The state of the bus (busy or free) is not indicated in the user interface.

#### 24.12.2.2 TWI as Master or Slave

The automatic reversal from Master to Slave is not supported in case of a lost arbitration.

Then, in the case where TWI may be either a Master or a Slave, the programmer must manage the pseudo Multi-master mode described in the steps below.

1. Program TWI in Slave mode (SADR + MSDIS + SVEN) and perform Slave Access (if TWI is addressed).
2. If TWI has to be set in Master mode, wait until TXCOMP flag is at 1.
3. Program Master mode (DADR + SVDIS + MSEN) and start the transfer (ex: START + Write in THR).
4. As soon as the Master mode is enabled, TWI scans the bus in order to detect if it is busy or free. When the bus is considered as free, TWI initiates the transfer.
5. As soon as the transfer is initiated and until a STOP condition is sent, the arbitration becomes relevant and the user must monitor the ARBLST flag.
6. If the arbitration is lost (ARBLST is set to 1), the user must program the TWI in Slave mode in the case where the Master that won the arbitration wanted to access the TWI.

7. If TWI has to be set in Slave mode, wait until TXCOMP flag is at 1 and then program the Slave mode.

Note: In the case where the arbitration is lost and TWI is addressed, TWI will not acknowledge even if it is programmed in Slave mode as soon as ARBLST is set to 1. Then, the Master must repeat SADR.

Figure 24-19. Programmer Sends Data While the Bus is Busy

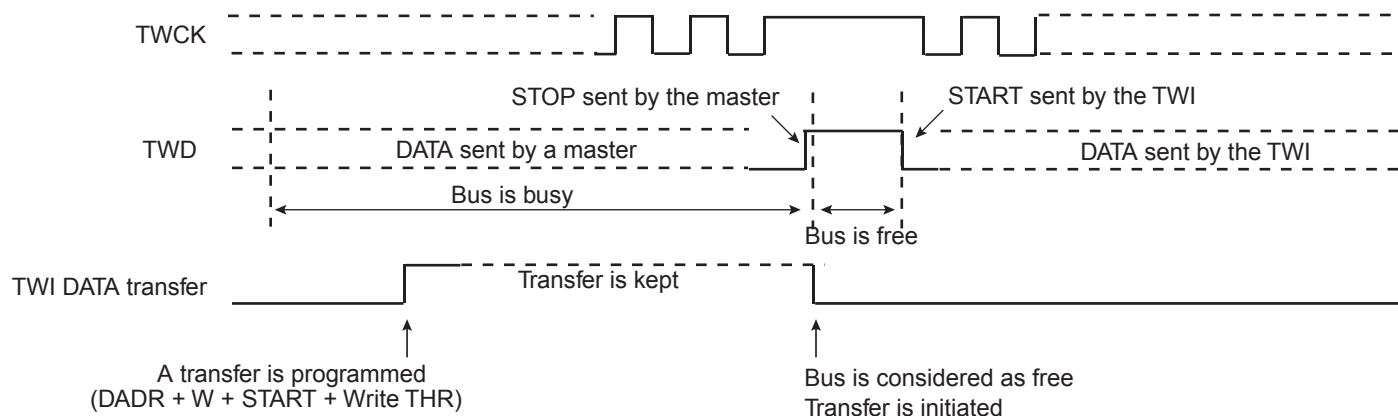
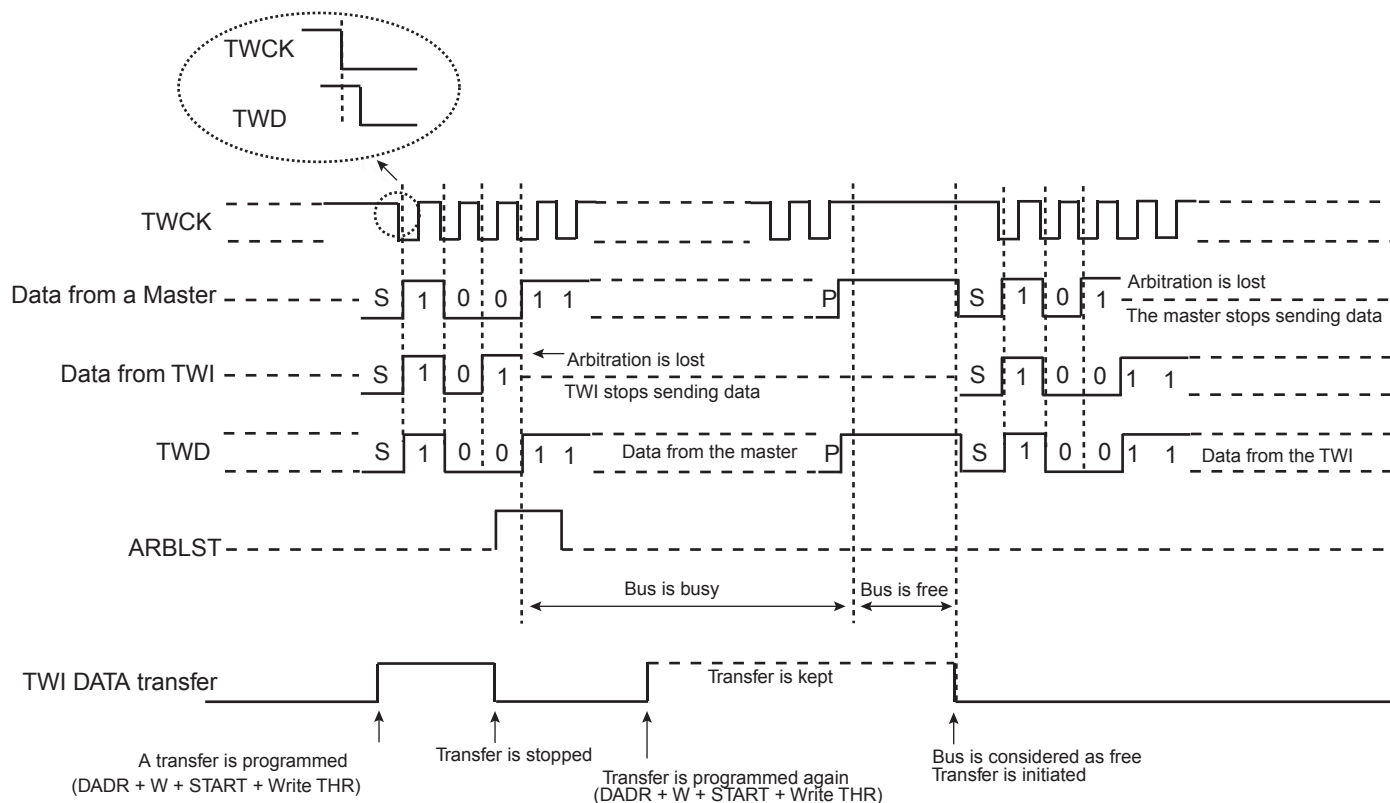
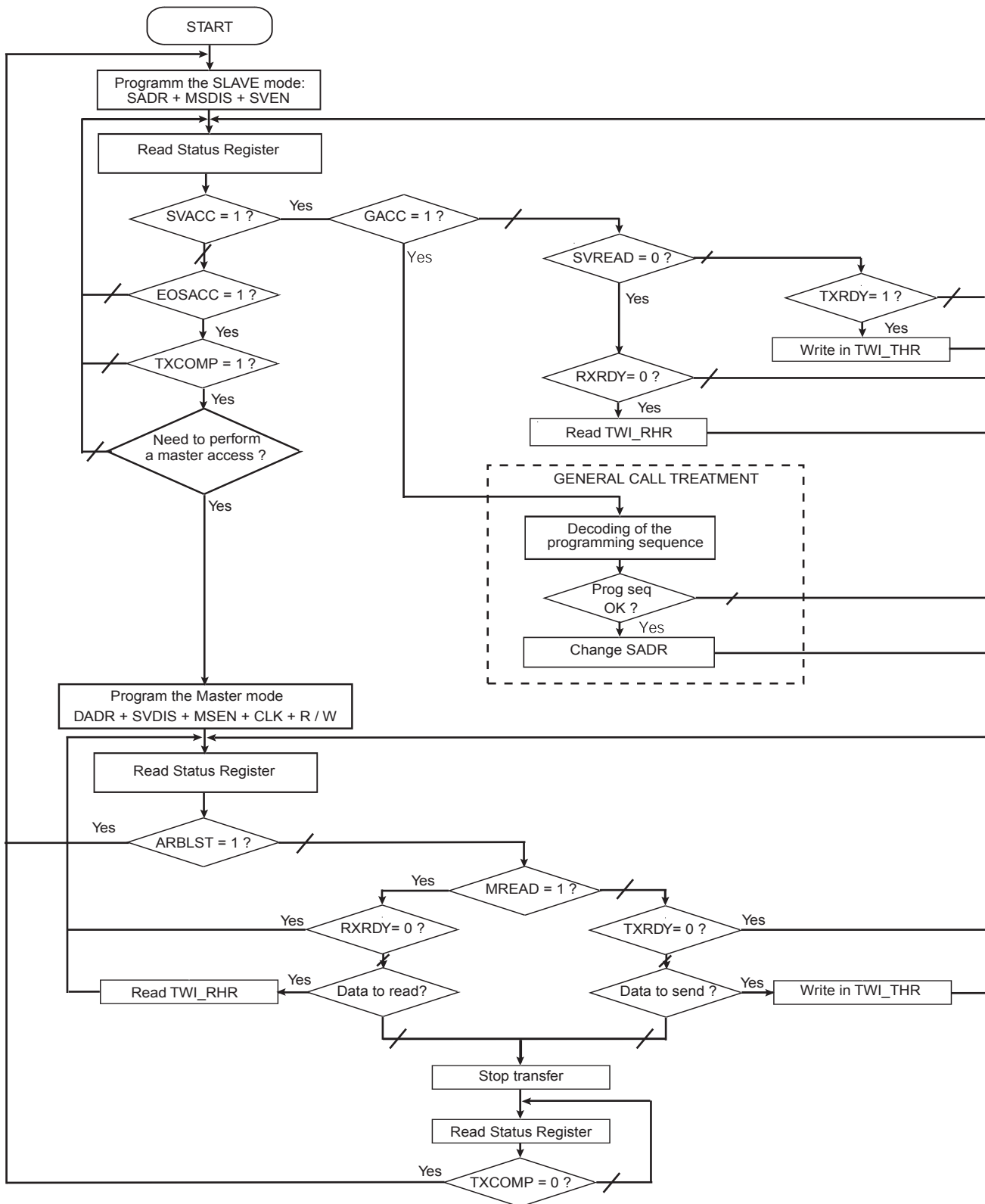

Figure 24-20. Arbitration Cases



The flowchart shown in [Figure 24-21 on page 237](#) gives an example of read and write operations in Multi-master mode.

Figure 24-21. Multi-master Flowchart



## 24.13 Slave Mode

### 24.13.1 Definition

The Slave Mode is defined as a mode where the device receives the clock and the address from another device called the master.

In this mode, the device never initiates and never completes the transmission (START, REPEATED\_START and STOP conditions are always provided by the master).

### 24.13.2 Application Block Diagram

Figure 24-22. Slave Mode Typical Application Block Diagram

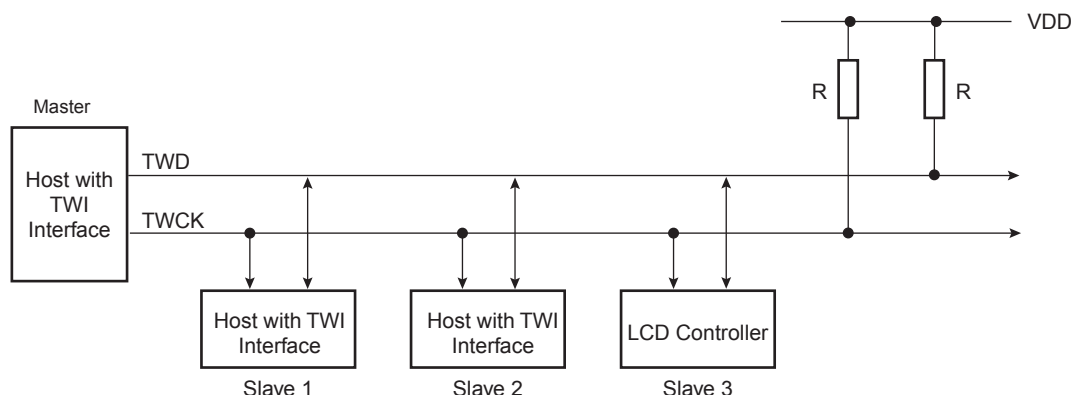

### 24.13.3 Programming Slave Mode

The following fields must be programmed before entering Slave mode:

1. SADR (SMR): The slave device address is used in order to be accessed by master devices in read or write mode.
2. MSDIS (CR): Disable the master mode.
3. SVEN (CR): Enable the slave mode.

As the device receives the clock, values written in CWGR are not taken into account.

### 24.13.4 Receiving Data

After a Start or Repeated Start condition is detected and if the address sent by the Master matches with the Slave address programmed in the SADR (Slave ADDRESS) field, SVACC (Slave ACCESS) flag is set and SVREAD (Slave READ) indicates the direction of the transfer.

SVACC remains high until a STOP condition or a repeated START is detected. When such a condition is detected, EOSACC (End Of Slave ACCESS) flag is set.

#### 24.13.4.1 Read Sequence

In the case of a Read sequence (SVREAD is high), TWI transfers data written in the THR (TWI Transmit Holding Register) until a STOP condition or a REPEATED\_START + an address different from SADR is detected. Note that at the end of the read sequence TXCOMP (Transmission Complete) flag is set and SVACC reset.

As soon as data is written in the THR, TXRDY (Transmit Holding Register Ready) flag is reset, and it is set when the shift register is empty and the sent data acknowledged or not. If the data is not acknowledged, the NACK flag is set.

Note that a STOP or a repeated START always follows a NACK.

See [Figure 24-23 on page 240](#).

#### 24.13.4.2 Write Sequence

In the case of a Write sequence (SVREAD is low), the RXRDY (Receive Holding Register Ready) flag is set as soon as a character has been received in the RHR (TWI Receive Holding Register). RXRDY is reset when reading the RHR.

TWI continues receiving data until a STOP condition or a REPEATED\_START + an address different from SADR is detected. Note that at the end of the write sequence TXCOMP flag is set and SVACC reset.

See [Figure 24-24 on page 241](#).

#### 24.13.4.3 Clock Synchronization Sequence

In the case where THR or RHR is not written/read in time, TWI performs a clock synchronization.

Clock stretching information is given by the SCLWS (Clock Wait state) bit.

See [Figure 24-26 on page 242](#) and [Figure 24-27 on page 243](#).

#### 24.13.4.4 General Call

In the case where a GENERAL CALL is performed, GACC (General Call ACCESS) flag is set.

After GACC is set, it is up to the programmer to interpret the meaning of the GENERAL CALL and to decode the new address programming sequence.

See [Figure 24-25 on page 241](#).

#### 24.13.4.5 PDC

As it is impossible to know the exact number of data to receive/send, the use of PDC is NOT recommended in SLAVE mode.

As it is impossible to know the exact number of data to receive/send, the use of PDC is NOT recommended in SLAVE mode.

## 24.13.5 Data Transfer

### 24.13.5.1 Read Operation

The read mode is defined as a data requirement from the master.

After a START or a REPEATED START condition is detected, the decoding of the address starts. If the slave address (SADR) is decoded, SVACC is set and SVREAD indicates the direction of the transfer.

Until a STOP or REPEATED START condition is detected, TWI continues sending data loaded in the THR register.

If a STOP condition or a REPEATED START + an address different from SADR is detected, SVACC is reset.

Figure 24-23 on page 240 describes the write operation.

**Figure 24-23.** Read Access Ordered by a MASTER

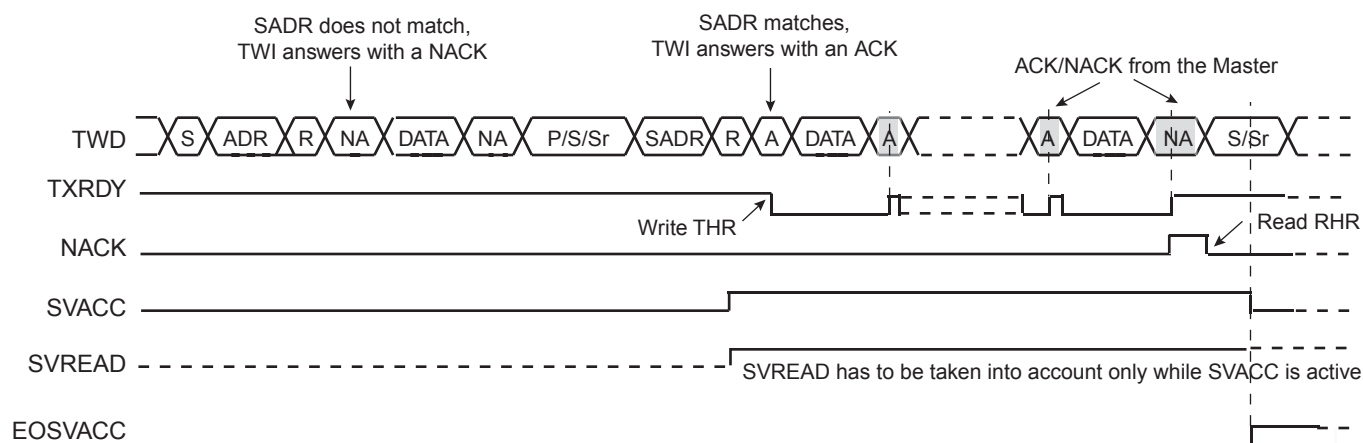

- Notes:
1. When SVACC is low, the state of SVREAD becomes irrelevant.
  2. TXRDY is reset when data has been transmitted from THR to the shift register and set when this data has been acknowledged or non acknowledged.

### 24.13.5.2 Write Operation

The write mode is defined as a data transmission from the master.

After a START or a REPEATED START, the decoding of the address starts. If the slave address is decoded, SVACC is set and SVREAD indicates the direction of the transfer (SVREAD is low in this case).

Until a STOP or REPEATED START condition is detected, TWI stores the received data in the RHR register.

If a STOP condition or a REPEATED START + an address different from SADR is detected, SVACC is reset.

Figure 24-24 on page 241 describes the Write operation.



**Figure 24-24. Write Access Ordered by a Master**

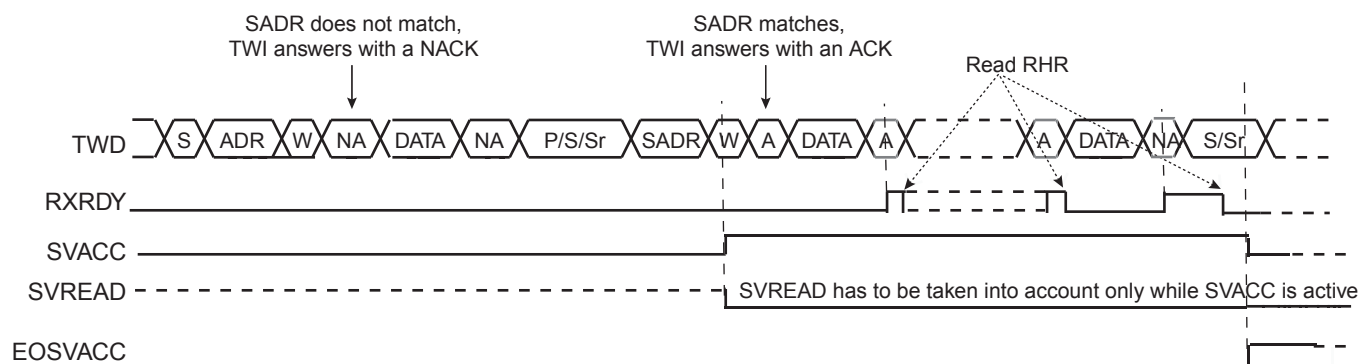

- Notes:
1. When SVACC is low, the state of SVREAD becomes irrelevant.
  2. RXRDY is set when data has been transmitted from the shift register to the RHR and reset when this data is read.

### 24.13.5.3 General Call

The general call is performed in order to change the address of the slave.

If a GENERAL CALL is detected, GACC is set.

After the detection of General Call, it is up to the programmer to decode the commands which come afterwards.

In case of a WRITE command, the programmer has to decode the programming sequence and program a new SADR if the programming sequence matches.

Figure 24-25 on page 241 describes the General Call access.

**Figure 24-25. Master Performs a General Call**

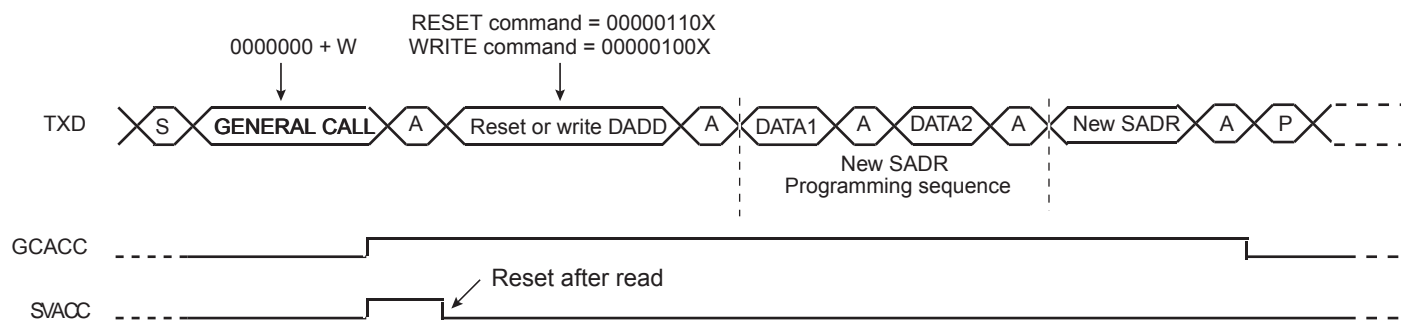

- Note:
1. This method allows the user to create an own programming sequence by choosing the programming bytes and the number of them. The programming sequence has to be provided to the master.

## 24.13.6 Clock Synchronization

In both read and write modes, it may happen that THR/RHR buffer is not filled /emptied before the emission/reception of a new character. In this case, to avoid sending/receiving undesired data, a clock stretching mechanism is implemented.

### 24.13.6.1 Clock Synchronization in Read Mode

The clock is tied low if the shift register is empty and if a STOP or REPEATED START condition was not detected. It is tied low until the shift register is loaded.

Figure 24-26 on page 242 describes the clock synchronization in Read mode.

**Figure 24-26.** Clock Synchronization in Read Mode

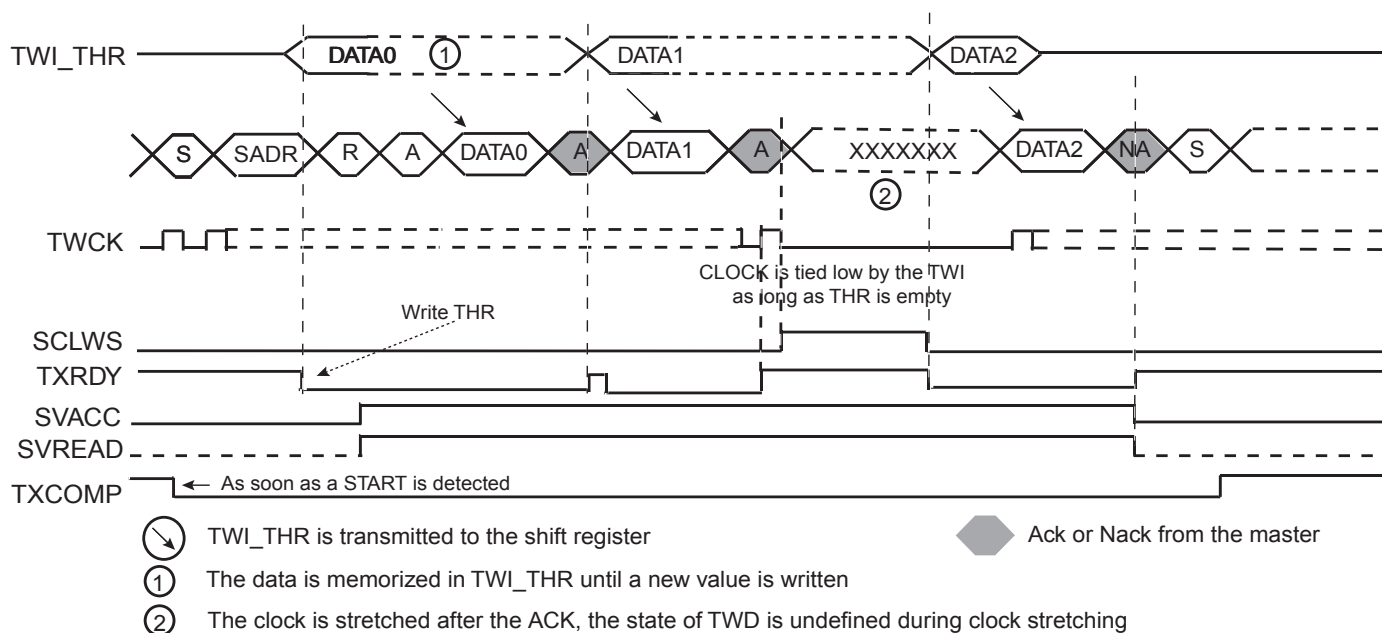

- Notes:
1. TXRDY is reset when data has been written in the TH to the shift register and set when this data has been acknowledged or non acknowledged.
  2. At the end of the read sequence, TXCOMP is set after a STOP or after a REPEATED\_START + an address different from SADR.
  3. SCLWS is automatically set when the clock synchronization mechanism is started.

## 24.13.6.2 Clock Synchronization in Write Mode

The clock is tied low if the shift register and the RHR is full. If a STOP or REPEATED\_START condition was not detected, it is tied low until RHR is read.

Figure 24-27 on page 243 describes the clock synchronization in Read mode.

**Figure 24-27.** Clock Synchronization in Write Mode

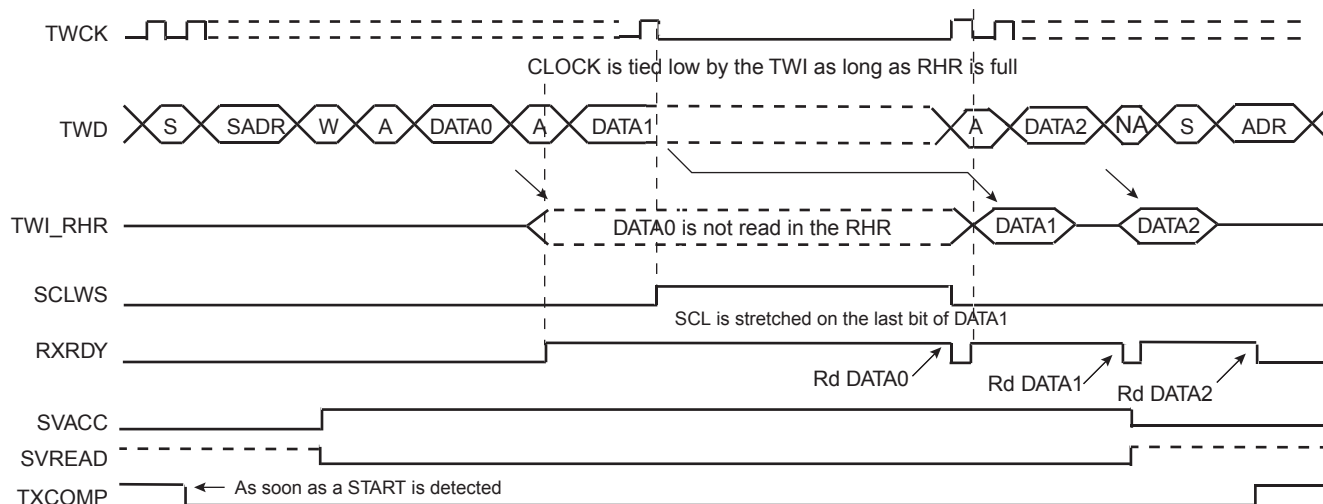

- Notes:
1. At the end of the read sequence, TXCOMP is set after a STOP or after a REPEATED\_START + an address different from SADR.
  2. SCLWS is automatically set when the clock synchronization mechanism is started and automatically reset when the mechanism is finished.

## 24.13.7 Reversal after a Repeated Start

### 24.13.7.1 Reversal of Read to Write

The master initiates the communication by a read command and finishes it by a write command.

Figure 24-28 on page 244 describes the repeated start + reversal from Read to Write mode.

**Figure 24-28.** Repeated Start + Reversal from Read to Write Mode

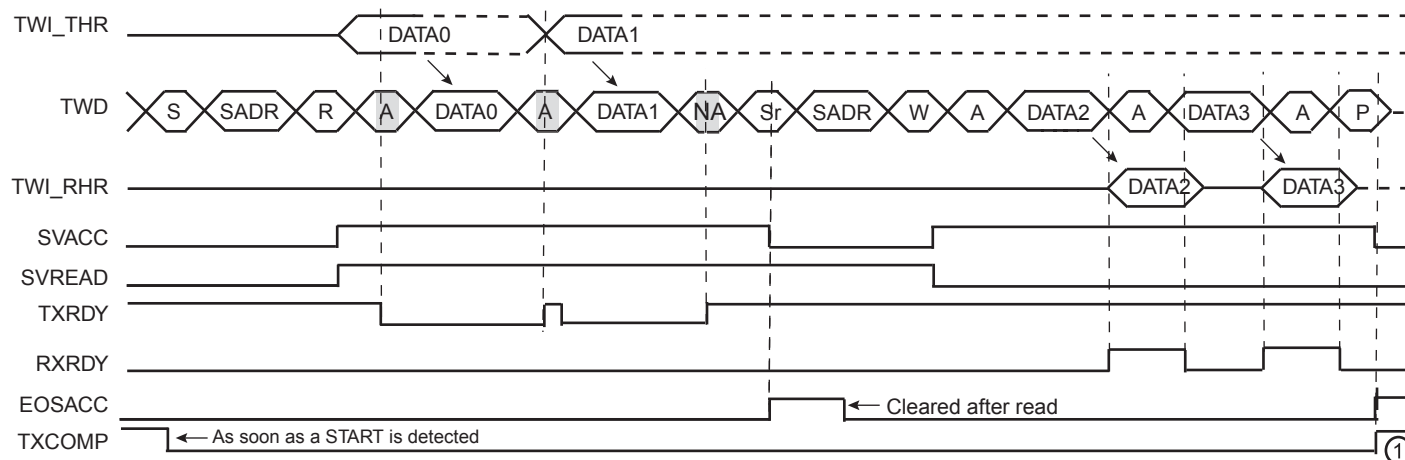

### 24.13.7.2 Reversal of Write to Read

The master initiates the communication by a write command and finishes it by a read command. Figure 24-29 on page 244 describes the repeated start + reversal from Write to Read mode.

**Figure 24-29.** Repeated Start + Reversal from Write to Read Mode

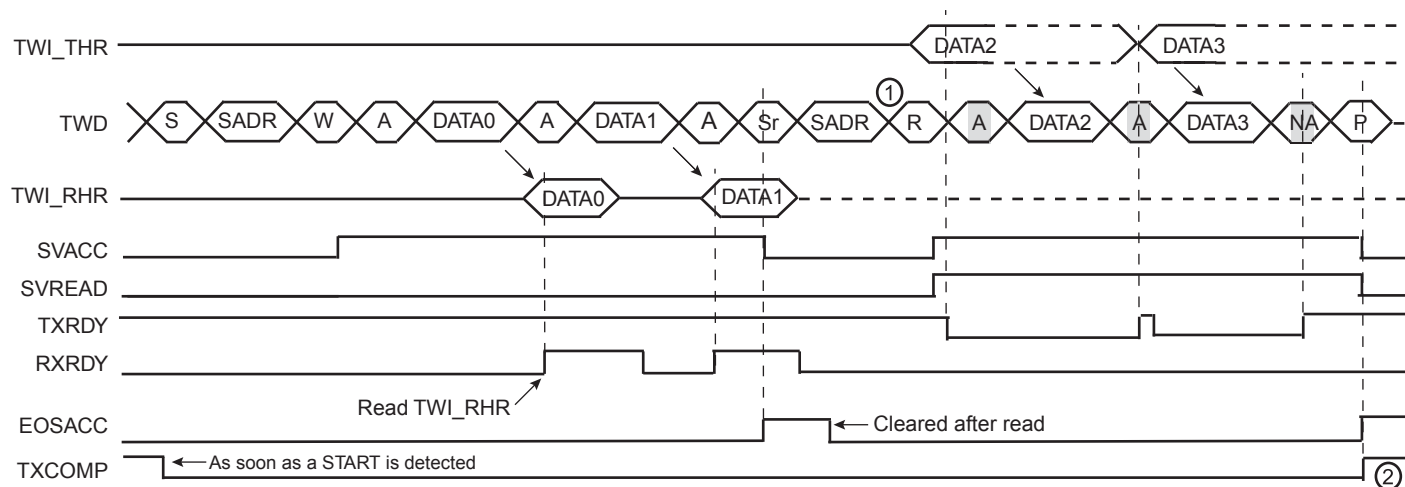

- Notes:
1. In this case, if THR has not been written at the end of the read command, the clock is automatically stretched before the ACK.
  2. TXCOMP is only set at the end of the transmission because after the repeated start, SADR is detected again.

24.13.8 Read Write Flowcharts

The flowchart shown in Figure 24-30 on page 245 gives an example of read and write operations in Slave mode. A polling or interrupt method can be used to check the status bits. The interrupt method requires that the interrupt enable register (IER) be configured first.

Figure 24-30. Read Write Flowchart in Slave Mode

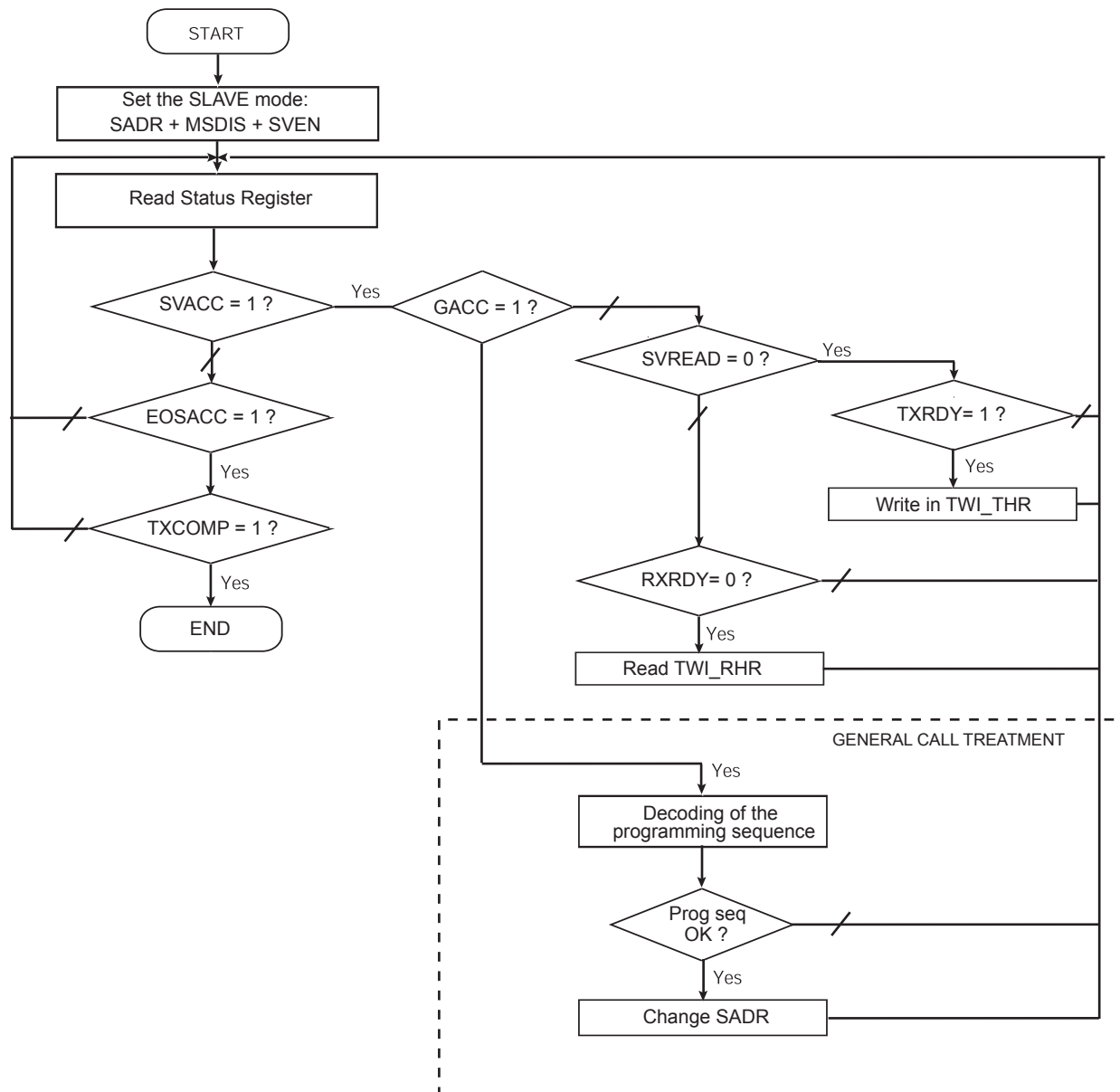

## 24.14 Two-wire Interface (TWI) User Interface

### 24.14.1 Register Mapping

**Table 24-4.** TWI User Interface

Offset	Register	Name	Access	Reset
0x00	Control Register	CR	Write-only	N / A
0x04	Master Mode Register	MMR	Read-write	0x00000000
0x08	Slave Mode Register	SMR	Read-write	0x00000000
0x0C	Internal Address Register	IADR	Read-write	0x00000000
0x10	Clock Waveform Generator Register	CWGR	Read-write	0x00000000
0x20	Status Register	SR	Read-only	0x0000F009
0x24	Interrupt Enable Register	IER	Write-only	N / A
0x28	Interrupt Disable Register	IDR	Write-only	N / A
0x2C	Interrupt Mask Register	IMR	Read-only	0x00000000
0x30	Receive Holding Register	RHR	Read-only	0x00000000
0x34	Transmit Holding Register	THR	Write-only	0x00000000
0x38 - 0xF8	Reserved	–	–	–
0xFC	Version Register	TWI_VER	Read-only	0x00000000 <sup>(1)</sup>
0x38 - 0xFC	Reserved	–	–	–

Note: 1. Values in the Version Register vary with the version of the IP block implementation.

### 24.14.2 TWI Control Register

**Name:** CR

**Access:** Write-only

**Reset Value:** 0x00000000

31	30	29	28	27	26	25	24
–	–	–	–	–	–	–	–
23	22	21	20	19	18	17	16
–	–	–	–	–	–	–	–
15	14	13	12	11	10	9	8
–	–	–	–	–	–	–	–
7	6	5	4	3	2	1	0
SWRST	–	SVDIS	SVEN	MSDIS	MSEN	STOP	START

- **START: Send a START Condition**

0 = No effect.

1 = A frame beginning with a START bit is transmitted according to the features defined in the mode register.

This action is necessary when the TWI peripheral wants to read data from a slave. When configured in Master Mode with a write operation, a frame is sent as soon as the user writes a character in the Transmit Holding Register (THR).

- **STOP: Send a STOP Condition**

0 = No effect.

1 = STOP Condition is sent just after completing the current byte transmission in master read mode.

- In single data byte master read, the START and STOP must both be set.
- In multiple data bytes master read, the STOP must be set after the last data received but one.
- In master read mode, if a NACK bit is received, the STOP is automatically performed.
- In multiple data write operation, when both THR and shift register are empty, a STOP condition is automatically sent.

- **MSEN: TWI Master Mode Enabled**

0 = No effect.

1 = If MSDIS = 0, the master mode is enabled.

Note: Switching from Slave to Master mode is only permitted when TXCOMP = 1.

- **MSDIS: TWI Master Mode Disabled**

0 = No effect.

1 = The master mode is disabled, all pending data is transmitted. The shifter and holding characters (if it contains data) are transmitted in case of write operation. In read operation, the character being transferred must be completely received before disabling.

- **SVEN: TWI Slave Mode Enabled**

0 = No effect.

1 = If SVDIS = 0, the slave mode is enabled.

Note: Switching from Master to Slave mode is only permitted when TXCOMP = 1.

- **SVDIS: TWI Slave Mode Disabled**

0 = No effect.

1 = The slave mode is disabled. The shifter and holding characters (if it contains data) are transmitted in case of read operation. In write operation, the character being transferred must be completely received before disabling.

- **SWRST: Software Reset**

0 = No effect.

1 = Equivalent to a system reset.

## 24.14.3 TWI Master Mode Register

**Name:** MMR

**Access:** Read-write

**Reset Value:** 0x00000000

31	30	29	28	27	26	25	24
–	–	–	–	–	–	–	–
23	22	21	20	19	18	17	16
–	DADR						
15	14	13	12	11	10	9	8
–	–	–	MREAD	–	–	IADRSZ	
7	6	5	4	3	2	1	0
–	–	–	–	–	–	–	–

- **IADRSZ: Internal Device Address Size**

IADRSZ[9:8]		Description
0	0	No internal device address
0	1	One-byte internal device address
1	0	Two-byte internal device address
1	1	Three-byte internal device address

- **MREAD: Master Read Direction**

0 = Master write direction.

1 = Master read direction.

- **DADR: Device Address**

The device address is used to access slave devices in read or write mode. Those bits are only used in Master mode.



## 24.14.4 TWI Slave Mode Register

**Name:** SMR

**Access:** Read-write

**Reset Value:** 0x00000000

31	30	29	28	27	26	25	24
–	–	–	–	–	–	–	–
23	22	21	20	19	18	17	16
–	SADR						
15	14	13	12	11	10	9	8
–	–	–	–	–	–	–	–
7	6	5	4	3	2	1	0
–	–	–	–	–	–	–	–

- **SADR: Slave Address**

The slave device address is used in Slave mode in order to be accessed by master devices in read or write mode.

SADR must be programmed before enabling the Slave mode or after a general call. Writes at other times have no effect.

## 24.14.5 TWI Internal Address Register

**Name:** IADR

**Access:** Read-write

**Reset Value:** 0x00000000

31	30	29	28	27	26	25	24
–	–	–	–	–	–	–	–
23	22	21	20	19	18	17	16
IADR							
15	14	13	12	11	10	9	8
IADR							
7	6	5	4	3	2	1	0
IADR							

- **IADR: Internal Address**

0, 1, 2 or 3 bytes depending on IADRSZ.

## 24.14.6 TWI Clock Waveform Generator Register

**Name:** CWGR

**Access:** Read-write

**Reset Value:** 0x00000000

31	30	29	28	27	26	25	24
–	–	–	–	–	–	–	–
23	22	21	20	19	18	17	16
					CKDIV		
15	14	13	12	11	10	9	8
CHDIV							
7	6	5	4	3	2	1	0
CLDIV							

CWGR is only used in Master mode.

- **CLDIV: Clock Low Divider**

The SCL low period is defined as follows:

$$T_{low} = ((CLDIV \times 2^{CKDIV}) + 4) \times T_{MCK}$$

- **CHDIV: Clock High Divider**

The SCL high period is defined as follows:

$$T_{high} = ((CHDIV \times 2^{CKDIV}) + 4) \times T_{MCK}$$

- **CKDIV: Clock Divider**

The CKDIV is used to increase both SCL high and low periods.

## 24.14.7 TWI Status Register

**Name:** SR

**Access:** Read-only

**Reset Value:** 0x0000F009

31	30	29	28	27	26	25	24
–	–	–	–	–	–	–	–
23	22	21	20	19	18	17	16
–	–	–	–	–	–	–	–
15	14	13	12	11	10	9	8
TXBUFE	RXBUFF	ENDTX	ENDRX	EOSACC	SCLWS	ARBLST	NACK
7	6	5	4	3	2	1	0
–	OVRE	GACC	SVACC	SVREAD	TXRDY	RXRDY	TXCOMP

- **TXCOMP: Transmission Completed (automatically set / reset)**

**TXCOMP used in Master mode:**

0 = During the length of the current frame.

1 = When both holding and shifter registers are empty and STOP condition has been sent.

TXCOMP behavior in Master mode can be seen in [Figure 24-8 on page 225](#) and in [Figure 24-10 on page 226](#).

**TXCOMP used in Slave mode:**

0 = As soon as a Start is detected.

1 = After a Stop or a Repeated Start + an address different from SADR is detected.

TXCOMP behavior in Slave mode can be seen in [Figure 24-26 on page 242](#), [Figure 24-27 on page 243](#), [Figure 24-28 on page 244](#) and [Figure 24-29 on page 244](#).

- **RXRDY: Receive Holding Register Ready (automatically set / reset)**

0 = No character has been received since the last RHR read operation.

1 = A byte has been received in the RHR since the last read.

RXRDY behavior in Master mode can be seen in [Figure 24-10 on page 226](#).

RXRDY behavior in Slave mode can be seen in [Figure 24-24 on page 241](#), [Figure 24-27 on page 243](#), [Figure 24-28 on page 244](#) and [Figure 24-29 on page 244](#).

- **TXRDY: Transmit Holding Register Ready (automatically set / reset)**

**TXRDY used in Master mode:**

0 = The transmit holding register has not been transferred into shift register. Set to 0 when writing into THR register.

1 = As soon as a data byte is transferred from THR to internal shifter or if a NACK error is detected, TXRDY is set at the same time as TXCOMP and NACK. TXRDY is also set when MSEN is set (enable TWI).

*TXRDY behavior in Master mode* can be seen in [Figure 24-8 on page 225](#).

**TXRDY used in Slave mode:**

0 = As soon as data is written in the THR, until this data has been transmitted and acknowledged (ACK or NACK).

1 = It indicates that the THR is empty and that data has been transmitted and acknowledged.

If TXRDY is high and if a NACK has been detected, the transmission will be stopped. Thus when TRDY = NACK = 1, the programmer must not fill THR to avoid losing it.

TXRDY behavior in Slave mode can be seen in [Figure 24-23 on page 240](#), [Figure 24-26 on page 242](#), [Figure 24-28 on page 244](#) and [Figure 24-29 on page 244](#).

- **SVREAD: Slave Read (automatically set / reset)**

This bit is only used in Slave mode. When SVACC is low (no Slave access has been detected) SVREAD is irrelevant.

0 = Indicates that a write access is performed by a Master.

1 = Indicates that a read access is performed by a Master.

SVREAD behavior can be seen in [Figure 24-23 on page 240](#), [Figure 24-24 on page 241](#), [Figure 24-28 on page 244](#) and [Figure 24-29 on page 244](#).

- **SVACC: Slave Access (automatically set / reset)**

This bit is only used in Slave mode.

0 = TWI is not addressed. SVACC is automatically cleared after a NACK or a STOP condition is detected.

1 = Indicates that the address decoding sequence has matched (A Master has sent SADR). SVACC remains high until a NACK or a STOP condition is detected.

SVACC behavior can be seen in [Figure 24-23 on page 240](#), [Figure 24-24 on page 241](#), [Figure 24-28 on page 244](#) and [Figure 24-29 on page 244](#).

- **GACC: General Call Access (clear on read)**

This bit is only used in Slave mode.

0 = No General Call has been detected.

1 = A General Call has been detected. After the detection of General Call, the programmer decoded the commands that follow and the programming sequence.

GACC behavior can be seen in [Figure 24-25 on page 241](#).

- **OVRE: Overrun Error (clear on read)**

This bit is only used in Master mode.

0 = RHR has not been loaded while RXRDY was set

1 = RHR has been loaded while RXRDY was set. Reset by read in SR when TXCOMP is set.

- **NACK: Not Acknowledged (clear on read)**

**NACK used in Master mode:**

0 = Each data byte has been correctly received by the far-end side TWI slave component.

1 = A data byte has not been acknowledged by the slave component. Set at the same time as TXCOMP.

**NACK used in Slave Read mode:**

0 = Each data byte has been correctly received by the Master.

1 = In read mode, a data byte has not been acknowledged by the Master. When NACK is set the programmer must not fill THR even if TXRDY is set, because it means that the Master will stop the data transfer or re initiate it.

Note that in Slave Write mode all data are acknowledged by the TWI.

- **ARBLST: Arbitration Lost (clear on read)**

This bit is only used in Master mode.

0 = Arbitration won.

1 = Arbitration lost. Another master of the TWI bus has won the multi-master arbitration. TXCOMP is set at the same time.

- **SCLWS: Clock Wait State (automatically set / reset)**

This bit is only used in Slave mode.

0 = The clock is not stretched.

1 = The clock is stretched. THR / RHR buffer is not filled / emptied before the emission / reception of a new character.

SCLWS behavior can be seen in [Figure 24-26 on page 242](#) and [Figure 24-27 on page 243](#).

- **EOSACC: End Of Slave Access (clear on read)**

This bit is only used in Slave mode.

0 = A slave access is being performing.

1 = The Slave Access is finished. End Of Slave Access is automatically set as soon as SVACC is reset.

EOSACC behavior can be seen in [Figure 24-28 on page 244](#) and [Figure 24-29 on page 244](#)

- **ENDRX: End of RX buffer**

This bit is only used in Master mode.

0 = The Receive Counter Register has not reached 0 since the last write in RCR or RNCR.

1 = The Receive Counter Register has reached 0 since the last write in RCR or RNCR.

- **ENDTX: End of TX buffer**

This bit is only used in Master mode.

0 = The Transmit Counter Register has not reached 0 since the last write in TCR or TNCR.

1 = The Transmit Counter Register has reached 0 since the last write in TCR or TNCR.

- **RXBUFF: RX Buffer Full**

This bit is only used in Master mode.

0 = RCR or RNCR have a value other than 0.

1 = Both RCR and RNCR have a value of 0.

- **TXBUFE: TX Buffer Empty**

This bit is only used in Master mode.

0 = TCR or TNCR have a value other than 0.

1 = Both TCR and TNCR have a value of 0.

## 24.14.8 TWI Interrupt Enable Register

**Name:** IER

**Access:** Write-only

**Reset Value:** 0x00000000

31	30	29	28	27	26	25	24
–	–	–	–	–	–	–	–
23	22	21	20	19	18	17	16
–	–	–	–	–	–	–	–
15	14	13	12	11	10	9	8
TXBUFE	RXBUFF	ENDTX	ENDRX	EOSACC	SCL_WS	ARBLST	NACK
7	6	5	4	3	2	1	0
–	OVRE	GACC	SVACC	–	TXRDY	RXRDY	TXCOMP

- **TXCOMP:** Transmission Completed Interrupt Enable
- **RXRDY:** Receive Holding Register Ready Interrupt Enable
- **TXRDY:** Transmit Holding Register Ready Interrupt Enable
- **SVACC:** Slave Access Interrupt Enable
- **GACC:** General Call Access Interrupt Enable
- **OVRE:** Overrun Error Interrupt Enable
- **NACK:** Not Acknowledge Interrupt Enable
- **ARBLST:** Arbitration Lost Interrupt Enable
- **SCL\_WS:** Clock Wait State Interrupt Enable
- **EOSACC:** End Of Slave Access Interrupt Enable
- **ENDRX:** End of Receive Buffer Interrupt Enable
- **ENDTX:** End of Transmit Buffer Interrupt Enable
- **RXBUFF:** Receive Buffer Full Interrupt Enable
- **TXBUFE:** Transmit Buffer Empty Interrupt Enable

0 = No effect.

1 = Enables the corresponding interrupt.

## 24.14.9 TWI Interrupt Disable Register

**Name:** IDR

**Access:** Write-only

**Reset Value:** 0x00000000

31	30	29	28	27	26	25	24
–	–	–	–	–	–	–	–
23	22	21	20	19	18	17	16
–	–	–	–	–	–	–	–
15	14	13	12	11	10	9	8
TXBUFE	RXBUFF	ENDTX	ENDRX	EOSACC	SCL_WS	ARBLST	NACK
7	6	5	4	3	2	1	0
–	OVRE	GACC	SVACC	–	TXRDY	RXRDY	TXCOMP

- **TXCOMP:** Transmission Completed Interrupt Disable
- **RXRDY:** Receive Holding Register Ready Interrupt Disable
- **TXRDY:** Transmit Holding Register Ready Interrupt Disable
- **SVACC:** Slave Access Interrupt Disable
- **GACC:** General Call Access Interrupt Disable
- **OVRE:** Overrun Error Interrupt Disable
- **NACK:** Not Acknowledge Interrupt Disable
- **ARBLST:** Arbitration Lost Interrupt Disable
- **SCL\_WS:** Clock Wait State Interrupt Disable
- **EOSACC:** End Of Slave Access Interrupt Disable
- **ENDRX:** End of Receive Buffer Interrupt Disable
- **ENDTX:** End of Transmit Buffer Interrupt Disable
- **RXBUFF:** Receive Buffer Full Interrupt Disable
- **TXBUFE:** Transmit Buffer Empty Interrupt Disable

0 = No effect.

1 = Disables the corresponding interrupt.



## 24.14.10 TWI Interrupt Mask Register

**Name:** IMR

**Access:** Read-only

**Reset Value:** 0x00000000

31	30	29	28	27	26	25	24
–	–	–	–	–	–	–	–
23	22	21	20	19	18	17	16
–	–	–	–	–	–	–	–
15	14	13	12	11	10	9	8
TXBUFE	RXBUFF	ENDTX	ENDRX	EOSACC	SCL_WS	ARBLST	NACK
7	6	5	4	3	2	1	0
–	OVRE	GACC	SVACC	–	TXRDY	RXRDY	TXCOMP

- **TXCOMP:** Transmission Completed Interrupt Mask
- **RXRDY:** Receive Holding Register Ready Interrupt Mask
- **TXRDY:** Transmit Holding Register Ready Interrupt Mask
- **SVACC:** Slave Access Interrupt Mask
- **GACC:** General Call Access Interrupt Mask
- **OVRE:** Overrun Error Interrupt Mask
- **NACK:** Not Acknowledge Interrupt Mask
- **ARBLST:** Arbitration Lost Interrupt Mask
- **SCL\_WS:** Clock Wait State Interrupt Mask
- **EOSACC:** End Of Slave Access Interrupt Mask
- **ENDRX:** End of Receive Buffer Interrupt Mask
- **ENDTX:** End of Transmit Buffer Interrupt Mask
- **RXBUFF:** Receive Buffer Full Interrupt Mask
- **TXBUFE:** Transmit Buffer Empty Interrupt Mask

0 = The corresponding interrupt is disabled.

1 = The corresponding interrupt is enabled.

## 24.14.11 TWI Receive Holding Register

**Name:** RHR

**Access:** Read-only

**Reset Value:** 0x00000000

31	30	29	28	27	26	25	24
–	–	–	–	–	–	–	–
23	22	21	20	19	18	17	16
–	–	–	–	–	–	–	–
15	14	13	12	11	10	9	8
–	–	–	–	–	–	–	–
7	6	5	4	3	2	1	0
RXDATA							

- **RXDATA: Master or Slave Receive Holding Data**

### 24.14.12 TWI Transmit Holding Register

**Name:** THR

**Access:** Read-write

**Reset Value:** 0x00000000

31	30	29	28	27	26	25	24
–	–	–	–	–	–	–	–
23	22	21	20	19	18	17	16
–	–	–	–	–	–	–	–
15	14	13	12	11	10	9	8
–	–	–	–	–	–	–	–
7	6	5	4	3	2	1	0
TXDATA							

- **TXDATA: Master or Slave Transmit Holding Data**

## 25. Synchronous Serial Controller (SSC)

Rev: 3.0.0.2

### 25.1 Features

- Provides Serial Synchronous Communication Links Used in Audio and Telecom Applications
- Contains an Independent Receiver and Transmitter and a Common Clock Divider
- Interfaced with Two PDCA Channels (DMA Access) to Reduce Processor Overhead
- Offers a Configurable Frame Sync and Data Length
- Receiver and Transmitter Can be Programmed to Start Automatically or on Detection of Different Events on the Frame Sync Signal
- Receiver and Transmitter Include a Data Signal, a Clock Signal and a Frame Synchronization Signal

### 25.2 Overview

The Atmel Synchronous Serial Controller (SSC) provides a synchronous communication link with external devices. It supports many serial synchronous communication protocols generally used in audio and telecom applications such as I2S, Short Frame Sync, Long Frame Sync, etc.

The SSC contains an independent receiver and transmitter and a common clock divider. The receiver and the transmitter each interface with three signals: the TX\_DATA/RX\_DATA signal for data, the TX\_CLOCK/RX\_CLOCK signal for the clock and the TX\_FRAME\_SYNC/RX\_FRAME\_SYNC signal for the Frame Sync. The transfers can be programmed to start automatically or on different events detected on the Frame Sync signal.

The SSC's high-level of programmability and its two dedicated PDCA channels of up to 32 bits permit a continuous high bit rate data transfer without processor intervention.

Featuring connection to two PDCA channels, the SSC permits interfacing with low processor overhead to the following:

- CODEC's in master or slave mode
- DAC through dedicated serial interface, particularly I2S
- Magnetic card reader

### 25.3 Block Diagram

Figure 25-1. Block Diagram

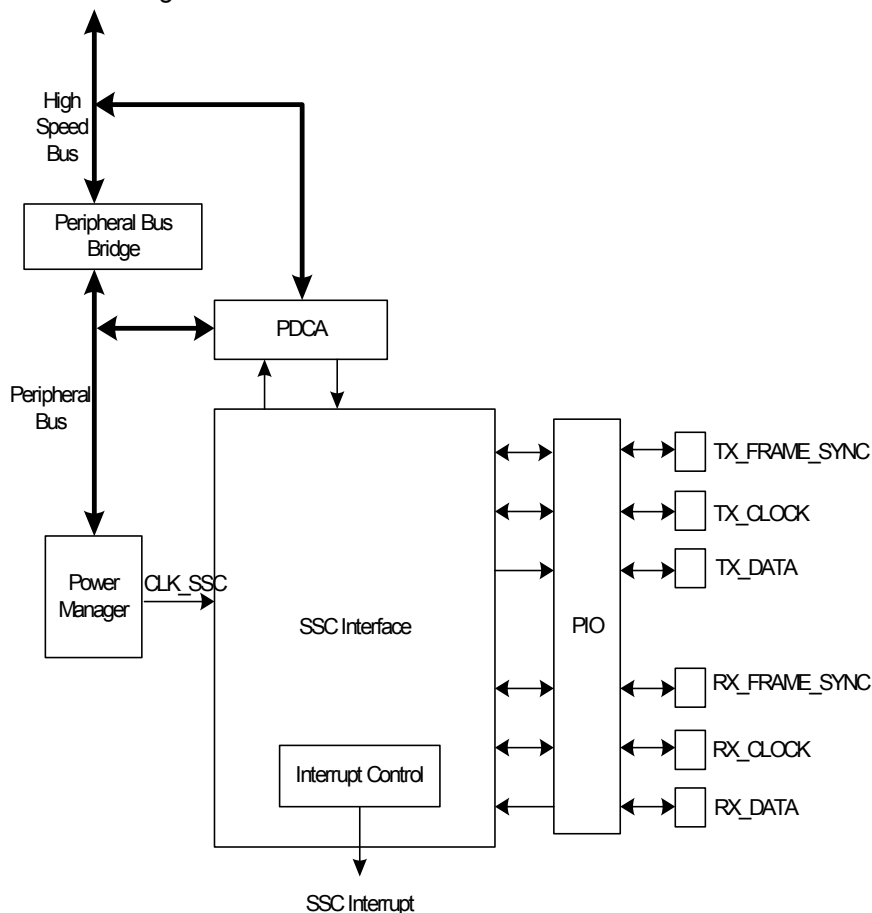

### 25.4 Application Block Diagram

Figure 25-2. Application Block Diagram

OS or RTOS Driver	Power Management	Interrupt Management	Test Management
SSC			
Serial AUDIO	Codec	Time Slot Management	Frame Management
			Line Interface

## 25.5 I/O Lines Description

**Table 25-1.** I/O Lines Description

Pin Name	Pin Description	Type
RX_FRAME_SYNC	Receiver Frame Synchro	Input/Output
RX_CLOCK	Receiver Clock	Input/Output
RX_DATA	Receiver Data	Input
TX_FRAME_SYNC	Transmitter Frame Synchro	Input/Output
TX_CLOCK	Transmitter Clock	Input/Output
TX_DATA	Transmitter Data	Output

## 25.6 Product Dependencies

### 25.6.1 I/O Lines

The pins used for interfacing the compliant external devices may be multiplexed with PIO lines.

Before using the SSC receiver, the PIO controller must be configured to dedicate the SSC receiver I/O lines to the SSC peripheral mode.

Before using the SSC transmitter, the PIO controller must be configured to dedicate the SSC transmitter I/O lines to the SSC peripheral mode.

### 25.6.2 Power Management

The SSC clock is generated by the power manager. Before using the SSC, the programmer must ensure that the SSC clock is enabled in the power manager.

In the SSC description, Master Clock (CLK\_SSC) is the bus clock of the peripheral bus to which the SSC is connected.

### 25.6.3 Interrupt

The SSC interface has an interrupt line connected to the interrupt controller. Handling interrupts requires programming the interrupt controller before configuring the SSC.

All SSC interrupts can be enabled/disabled configuring the SSC Interrupt mask register. Each pending and unmasked SSC interrupt will assert the SSC interrupt line. The SSC interrupt service routine can get the interrupt origin by reading the SSC interrupt status register.

## 25.7 Functional Description

This chapter contains the functional description of the following: SSC Functional Block, Clock Management, Data format, Start, Transmitter, Receiver and Frame Sync.

The receiver and transmitter operate separately. However, they can work synchronously by programming the receiver to use the transmit clock and/or to start a data transfer when transmission starts. Alternatively, this can be done by programming the transmitter to use the receive clock and/or to start a data transfer when reception starts. The transmitter and the receiver can be programmed to operate with the clock signals provided on either the TX\_CLOCK or RX\_CLOCK pins. This allows the SSC to support many slave-mode data transfers. The maximum clock speed allowed on the TX\_CLOCK and RX\_CLOCK pins is the master clock divided by 2.

**Figure 25-3.** SSC Functional Block Diagram

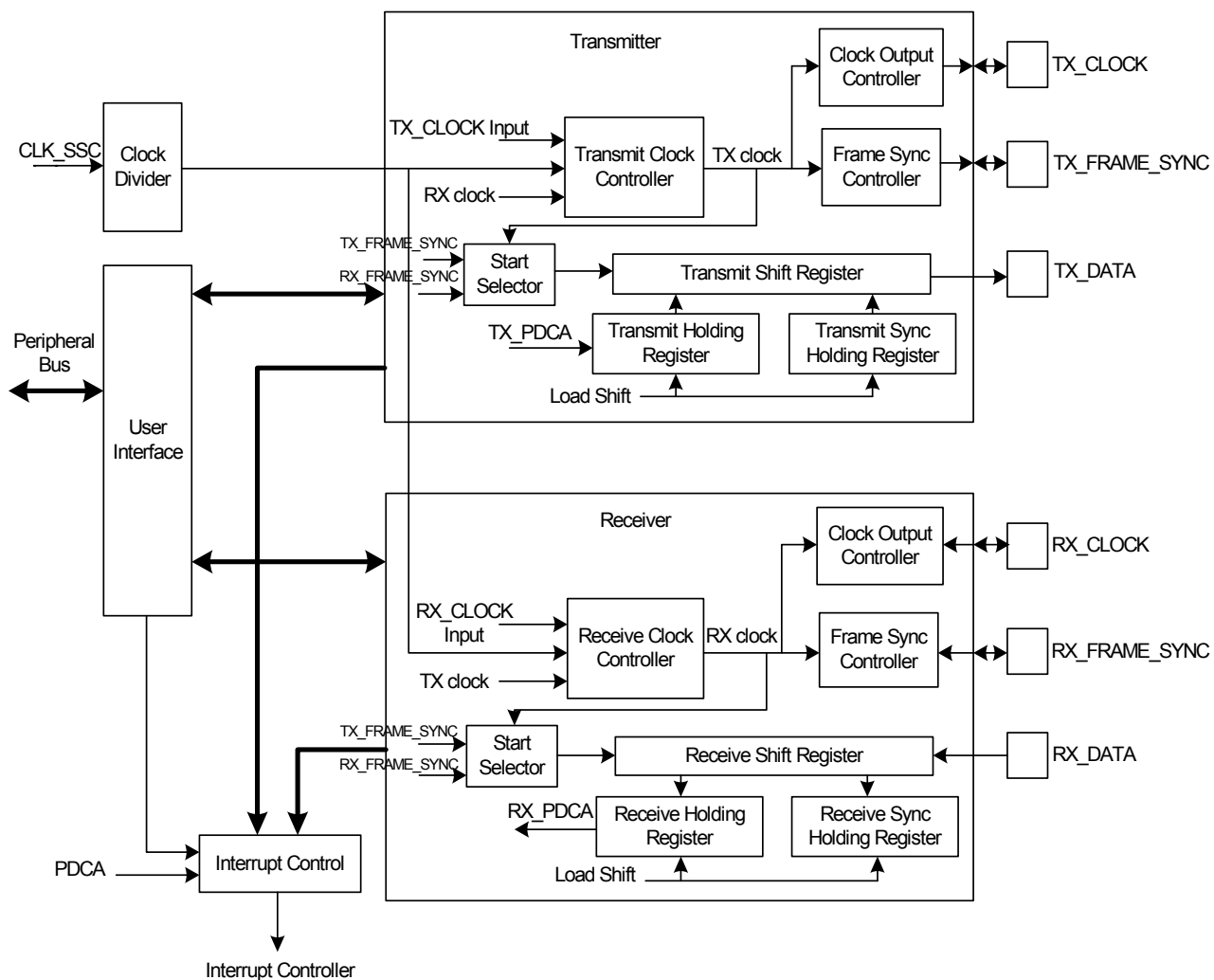

## 25.7.1 Clock Management

The transmitter clock can be generated by:

- an external clock received on the TX\_CLOCK I/O pad
- the receiver clock
- the internal clock divider

The receiver clock can be generated by:

- an external clock received on the RX\_CLOCK I/O pad
- the transmitter clock
- the internal clock divider

Furthermore, the transmitter block can generate an external clock on the TX\_CLOCK I/O pad, and the receiver block can generate an external clock on the RX\_CLOCK I/O pad.

This allows the SSC to support many Master and Slave Mode data transfers.

## 25.7.1.1 Clock Divider

**Figure 25-4.** Divided Clock Block Diagram

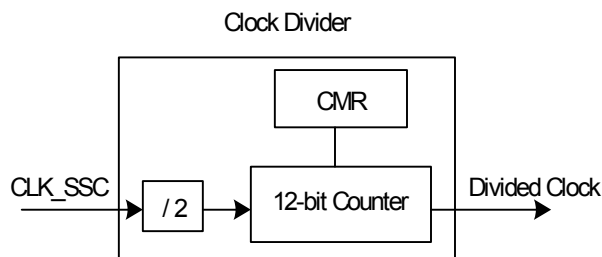

The Master Clock divider is determined by the 12-bit field DIV counter and comparator (so its maximal value is 4095) in the Clock Mode Register CMR, allowing a Master Clock division by up to 8190. The Divided Clock is provided to both the Receiver and Transmitter. When this field is programmed to 0, the Clock Divider is not used and remains inactive.

When DIV is set to a value equal to or greater than 1, the Divided Clock has a frequency of Master Clock divided by 2 times DIV. Each level of the Divided Clock has a duration of the Master Clock multiplied by DIV. This ensures a 50% duty cycle for the Divided Clock regardless of whether the DIV value is even or odd.

**Figure 25-5.** Divided Clock Generation

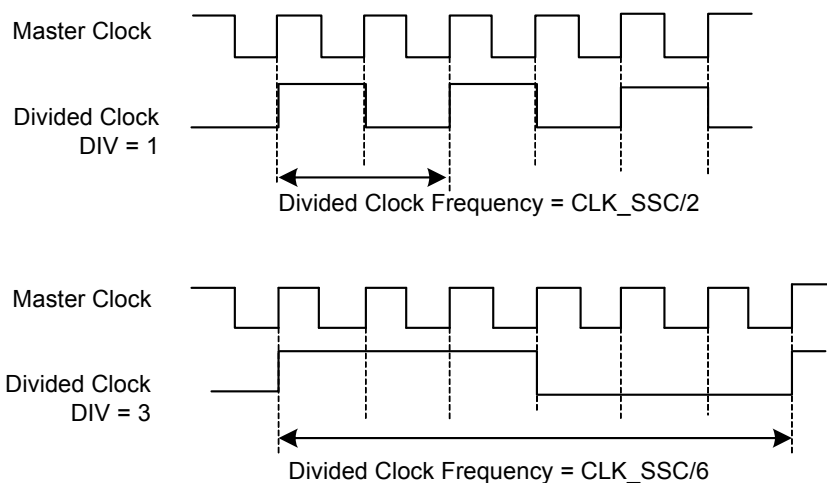

**Table 25-2.**

Maximum	Minimum
$CLK\_SSC / 2$	$CLK\_SSC / 8190$

## 25.7.1.2 Transmitter Clock Management

The transmitter clock is generated from the receiver clock or the divider clock or an external clock scanned on the TX\_CLOCK I/O pad. The transmitter clock is selected by the CKS field in TCMR (Transmit Clock Mode Register). Transmit Clock can be inverted independently by the CKI bits in TCMR.

The transmitter can also drive the TX\_CLOCK I/O pad continuously or be limited to the actual data transfer. The clock output is configured by the TCMR register. The Transmit Clock Inversion (CKI) bits have no effect on the clock outputs. Programming the TCMR register to select TX\_CLOCK pin (CKS field) and at the same time Continuous Transmit Clock (CKO field) might lead to unpredictable results.

**Figure 25-6.** Transmitter Clock Management

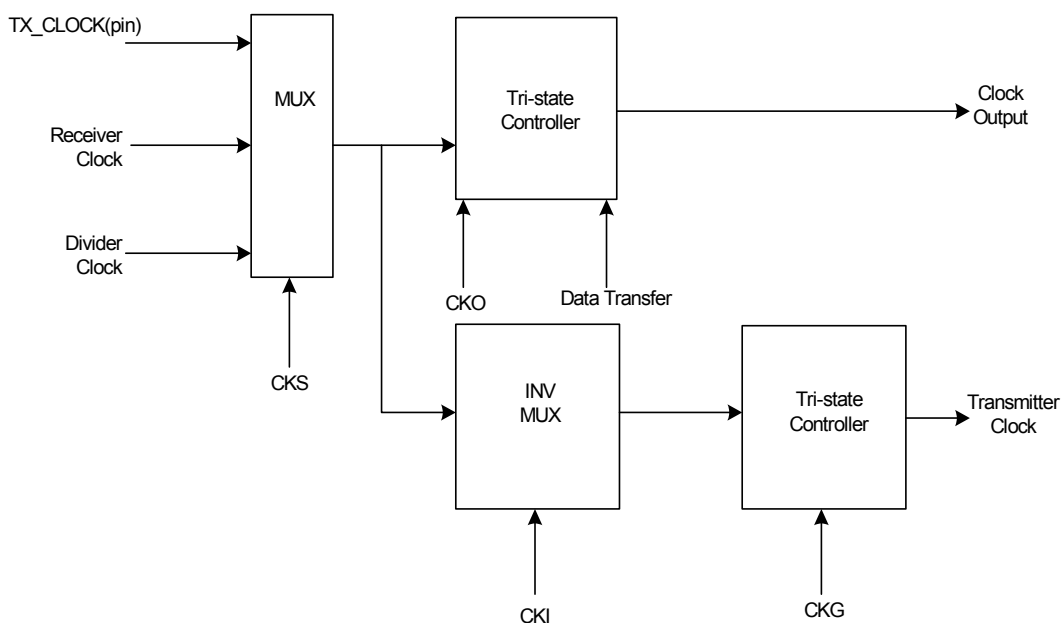

### 25.7.1.3 Receiver Clock Management

The receiver clock is generated from the transmitter clock or the divider clock or an external clock scanned on the RX\_CLOCK I/O pad. The Receive Clock is selected by the CKS field in RCMR (Receive Clock Mode Register). Receive Clocks can be inverted independently by the CKI bits in RCMR.

The receiver can also drive the RX\_CLOCK I/O pad continuously or be limited to the actual data transfer. The clock output is configured by the RCMR register. The Receive Clock Inversion (CKI) bits have no effect on the clock outputs. Programming the RCMR register to select RX\_CLOCK pin (CKS field) and at the same time Continuous Receive Clock (CKO field) can lead to unpredictable results.

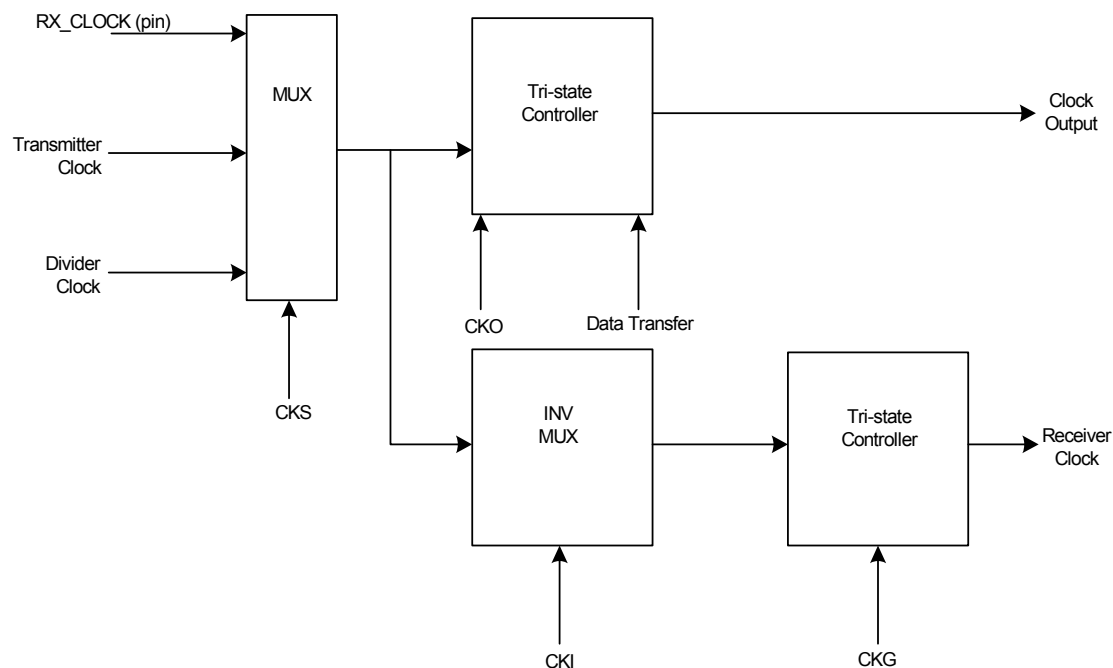

**Figure 25-7.** Receiver Clock Management

#### 25.7.1.4 Serial Clock Ratio Considerations

The Transmitter and the Receiver can be programmed to operate with the clock signals provided on either the TX\_CLOCK or RX\_CLOCK pins. This allows the SSC to support many slave-mode data transfers. In this case, the maximum clock speed allowed on the RX\_CLOCK pin is:

- Master Clock divided by 2 if Receiver Frame Synchro is input
- Master Clock divided by 3 if Receiver Frame Synchro is output

In addition, the maximum clock speed allowed on the TX\_CLOCK pin is:

- Master Clock divided by 6 if Transmit Frame Synchro is input
- Master Clock divided by 2 if Transmit Frame Synchro is output

#### 25.7.2 Transmitter Operations

A transmitted frame is triggered by a start event and can be followed by synchronization data before data transmission.

The start event is configured by setting the Transmit Clock Mode Register (TCMR). See Section “25.7.4” on page 267.

The frame synchronization is configured setting the Transmit Frame Mode Register (TFMR). See Section “25.7.5” on page 269.

To transmit data, the transmitter uses a shift register clocked by the transmitter clock signal and the start mode selected in the TCMR. Data is written by the application to the THR register then transferred to the shift register according to the data format selected.

When both the THR and the transmit shift register are empty, the status flag TXEMPTY is set in SR. When the Transmit Holding register is transferred in the Transmit shift register, the status flag TXRDY is set in SR and additional data can be loaded in the holding register.

**Figure 25-8.** Transmitter Block Diagram

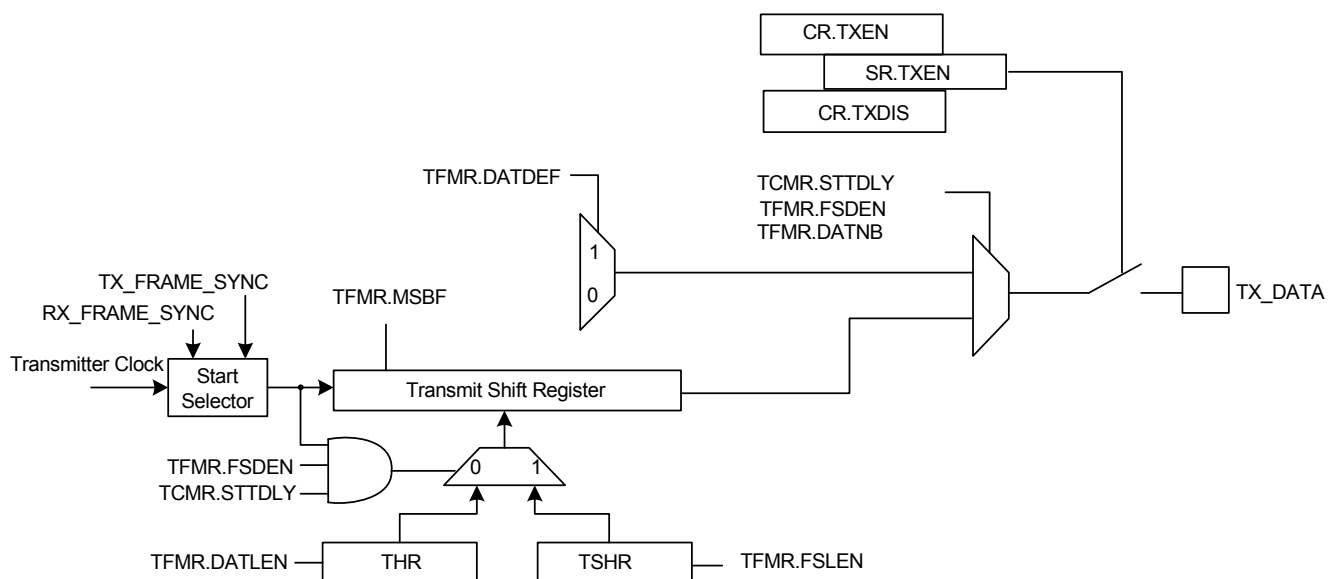

### 25.7.3 Receiver Operations

A received frame is triggered by a start event and can be followed by synchronization data before data transmission.

The start event is configured setting the Receive Clock Mode Register (RCMR). See Section “25.7.4” on page 267.

The frame synchronization is configured setting the Receive Frame Mode Register (RFMR). See Section “25.7.5” on page 269.

The receiver uses a shift register clocked by the receiver clock signal and the start mode selected in the RCMR. The data is transferred from the shift register depending on the data format selected.

When the receiver shift register is full, the SSC transfers this data in the holding register, the status flag RXRDY is set in SR and the data can be read in the receiver holding register. If another transfer occurs before read of the RHR register, the status flag OVERUN is set in SR and the receiver shift register is transferred in the RHR register.

**Figure 25-9. Receiver Block Diagram**

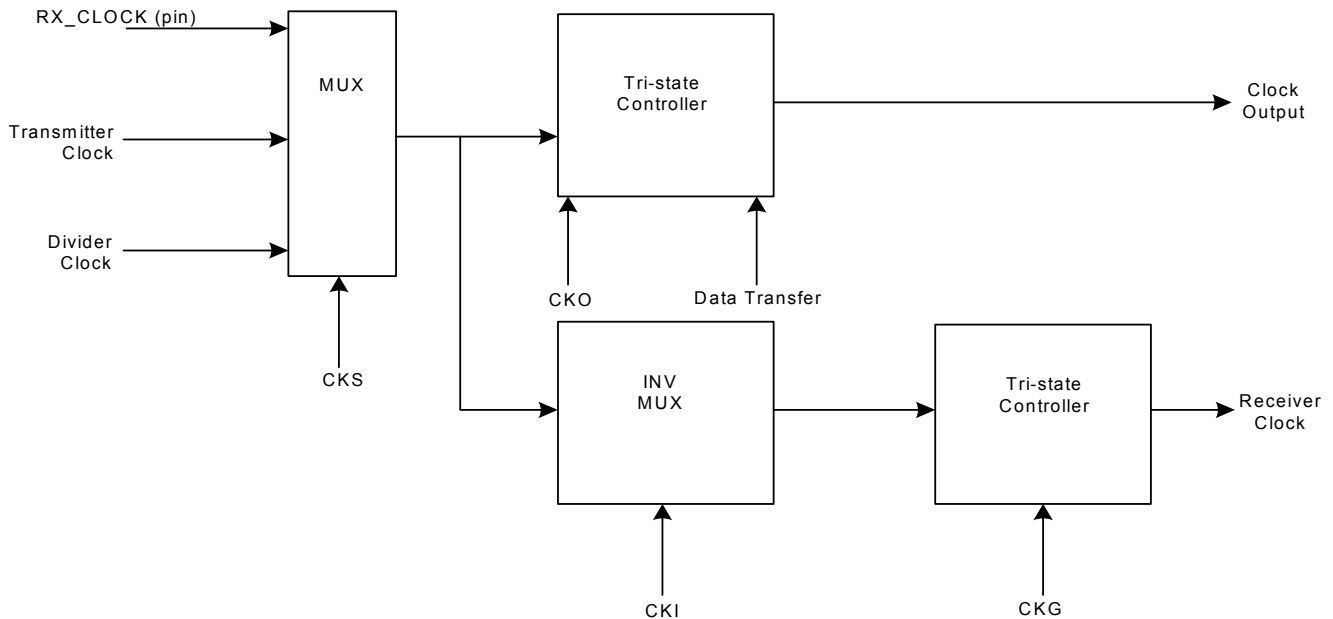

## 25.7.4 Start

The transmitter and receiver can both be programmed to start their operations when an event occurs, respectively in the Transmit Start Selection (START) field of TCMR and in the Receive Start Selection (START) field of RCMR.

Under the following conditions the start event is independently programmable:

- Continuous. In this case, the transmission starts as soon as a word is written in THR and the reception starts as soon as the Receiver is enabled.
- Synchronously with the transmitter/receiver
- On detection of a falling/rising edge on TX\_FRAME\_SYNC/RX\_FRAME\_SYNC
- On detection of a low level/high level on TX\_FRAME\_SYNC/RX\_FRAME\_SYNC
- On detection of a level change or an edge on TX\_FRAME\_SYNC/RX\_FRAME\_SYNC

A start can be programmed in the same manner on either side of the Transmit/Receive Clock Register (RCMR/TCMR). Thus, the start could be on TX\_FRAME\_SYNC (Transmit) or RX\_FRAME\_SYNC (Receive).

Moreover, the Receiver can start when data is detected in the bit stream with the Compare Functions.

Detection on TX\_FRAME\_SYNC/RX\_FRAME\_SYNC input/output is done by the field FSOS of the Transmit/Receive Frame Mode Register (TFMR/RFMR).

**Figure 25-10. Transmit Start Mode**

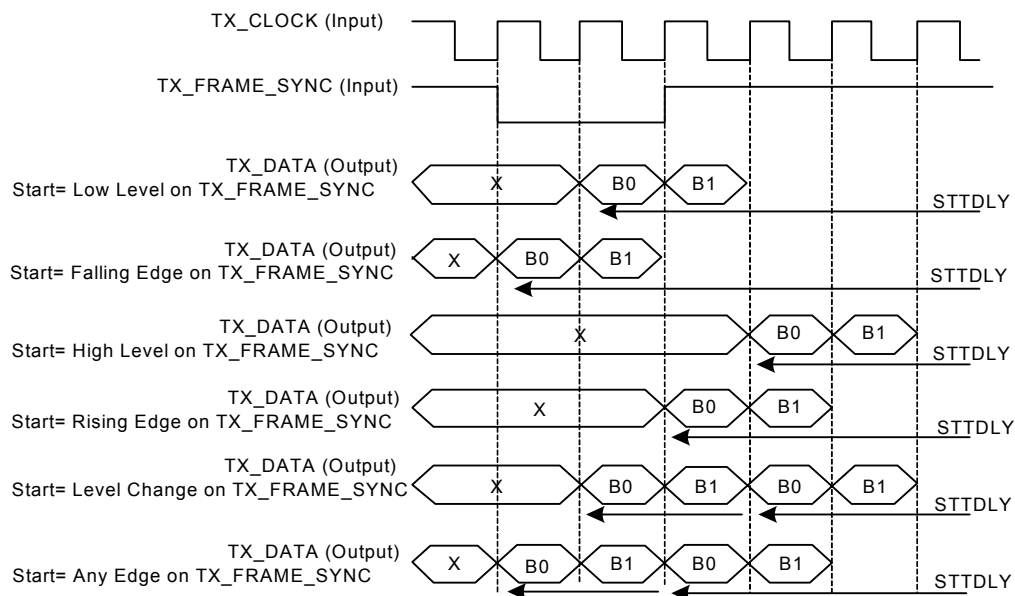

**Figure 25-11. Receive Pulse/Edge Start Modes**

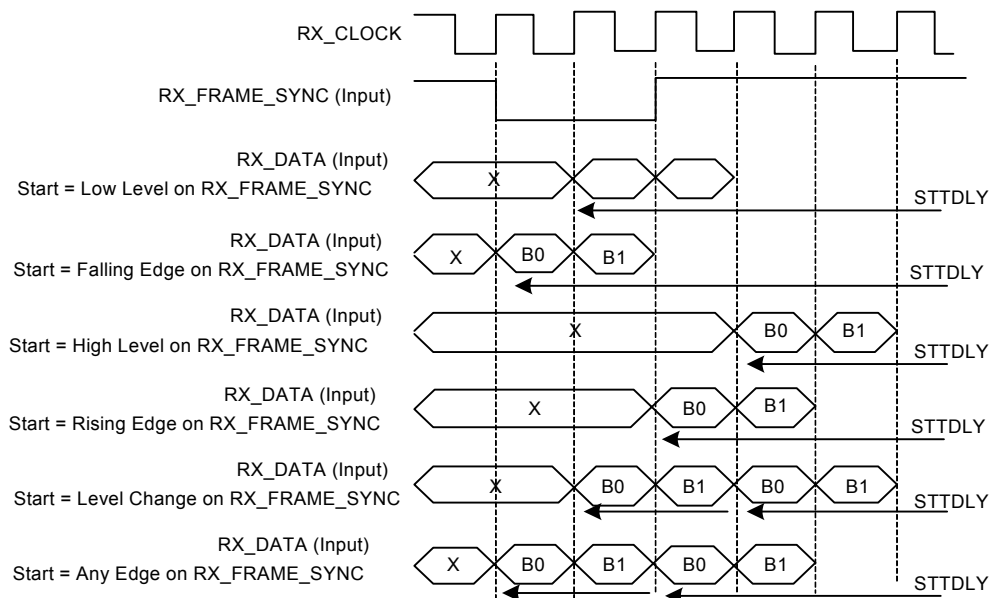

## 25.7.5 Frame Sync

The Transmitter and Receiver Frame Sync pins, TX\_FRAME\_SYNC and RX\_FRAME\_SYNC, can be programmed to generate different kinds of frame synchronization signals. The Frame Sync Output Selection (FSOS) field in the Receive Frame Mode Register (RFMR) and in the Transmit Frame Mode Register (TFMR) are used to select the required waveform.

- Programmable low or high levels during data transfer are supported.
- Programmable high levels before the start of data transfers or toggling are also supported.

If a pulse waveform is selected, the Frame Sync Length (FSLEN) field in RFMR and TFMR programs the length of the pulse, from 1 bit time up to 16 bit time.

The periodicity of the Receive and Transmit Frame Sync pulse output can be programmed through the Period Divider Selection (PERIOD) field in RCMR and TCMR.

### 25.7.5.1 Frame Sync Data

Frame Sync Data transmits or receives a specific tag during the Frame Sync signal.

During the Frame Sync signal, the Receiver can sample the RX\_DATA line and store the data in the Receive Sync Holding Register and the transmitter can transfer Transmit Sync Holding Register in the Shifter Register. The data length to be sampled/shifted out during the Frame Sync signal is programmed by the FSLEN field in RFMR/TFMR.

Concerning the Receive Frame Sync Data operation, if the Frame Sync Length is equal to or lower than the delay between the start event and the actual data reception, the data sampling operation is performed in the Receive Sync Holding Register through the Receive Shift Register.

The Transmit Frame Sync Operation is performed by the transmitter only if the bit Frame Sync Data Enable (FSDEN) in TFMR is set. If the Frame Sync length is equal to or lower than the delay between the start event and the actual data transmission, the normal transmission has priority and the data contained in the Transmit Sync Holding Register is transferred in the Transmit Register, then shifted out.

### 25.7.5.2 Frame Sync Edge Detection

The Frame Sync Edge detection is programmed by the FSEDGE field in RFMR/TFMR. This sets the corresponding flags RXSYN/TXSYN in the SSC Status Register (SR) on frame synchro edge detection (signals RX\_FRAME\_SYNC/TX\_FRAME\_SYNC).

## 25.7.6 Receive Compare Modes

**Figure 25-12.** Receive Compare Modes

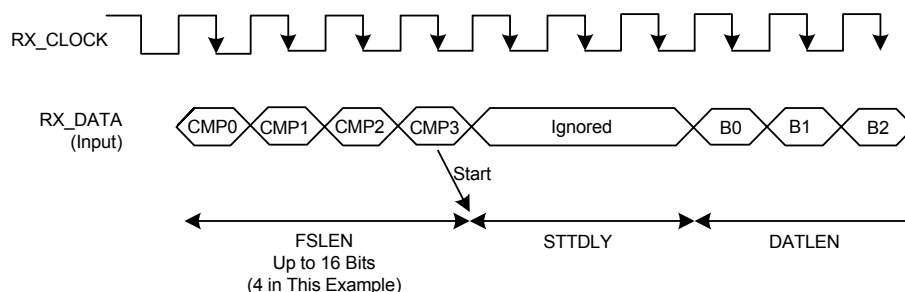

### 25.7.6.1 Compare Functions

Compare 0 can be one start event of the Receiver. In this case, the receiver compares at each new sample the last FSLEN bits received at the FSLEN lower bit of the data contained in the Compare 0 Register (RC0R). When this start event is selected, the user can program the Receiver to start a new data transfer either by writing a new Compare 0, or by receiving continuously until Compare 1 occurs. This selection is done with the bit (STOP) in RCMR.

## 25.7.7 Data Format

The data framing format of both the transmitter and the receiver are programmable through the Transmitter Frame Mode Register (TFMR) and the Receiver Frame Mode Register (RFMR). In either case, the user can independently select:

- the event that starts the data transfer (START)
- the delay in number of bit periods between the start event and the first data bit (STTDLY)
- the length of the data (DATLEN)
- the number of data to be transferred for each start event (DATNB).
- the length of synchronization transferred for each start event (FSLEN)
- the bit sense: most or lowest significant bit first (MSBF).

Additionally, the transmitter can be used to transfer synchronization and select the level driven on the TX\_DATA pin while not in data transfer operation. This is done respectively by the Frame Sync Data Enable (FSDEN) and by the Data Default Value (DATDEF) bits in TFMR.

**Table 25-3.** Data Frame Registers

Transmitter	Receiver	Field	Length	Comment
TFMR	RFMR	DATLEN	Up to 32	Size of word
TFMR	RFMR	DATNB	Up to 16	Number of words transmitted in frame
TFMR	RFMR	MSBF		Most significant bit first
TFMR	RFMR	FSLEN	Up to 16	Size of Synchro data register
TFMR		DATDEF	0 or 1	Data default value ended
TFMR		FSDEN		Enable send TSHR
TCMR	RCMR	PERIOD	Up to 512	Frame size
TCMR	RCMR	STTDLY	Up to 255	Size of transmit start delay

**Figure 25-13.** Transmit and Receive Frame Format in Edge/Pulse Start Modes

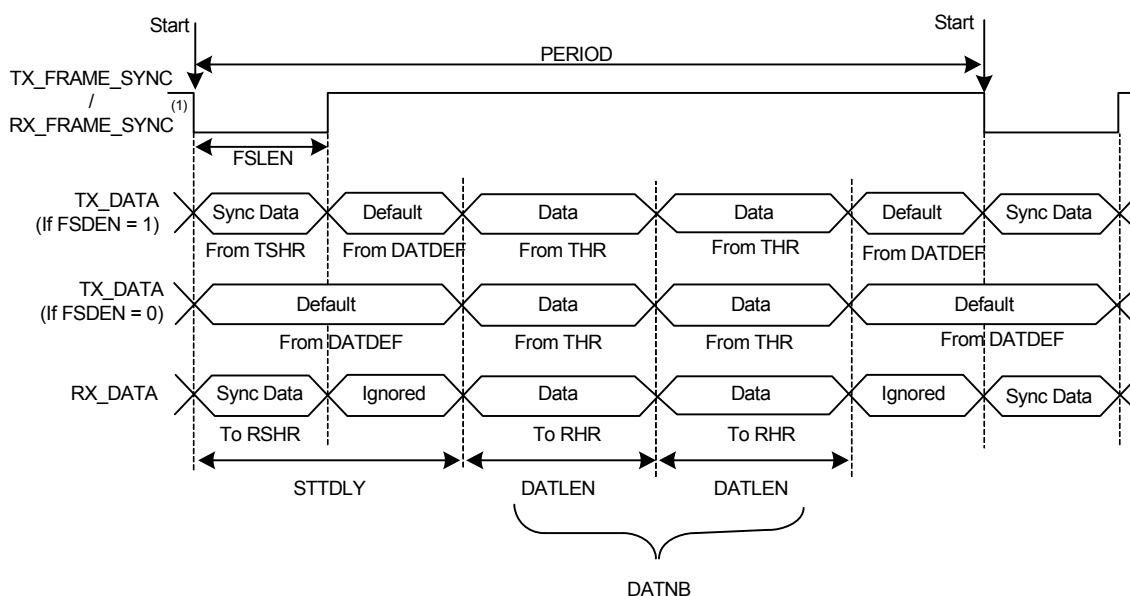

Note: 1. Example of input on falling edge of TX\_FRAME\_SYNC/RX\_FRAME\_SYNC.

**Figure 25-14.** Transmit Frame Format in Continuous Mode

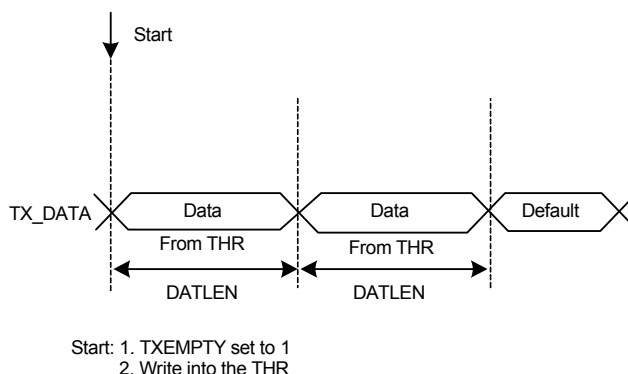

Note: 1. STTDLY is set to 0. In this example, THR is loaded twice. FSDEN value has no effect on the transmission. SyncData cannot be output in continuous mode.

**Figure 25-15.** Receive Frame Format in Continuous Mode

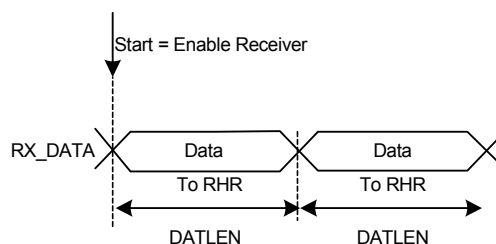

Note: 1. STTDLY is set to 0.

### 25.7.8 Loop Mode

The receiver can be programmed to receive transmissions from the transmitter. This is done by setting the Loop Mode (LOOP) bit in RFMR. In this case, RX\_DATA is connected to TX\_DATA, RX\_FRAME\_SYNC is connected to TX\_FRAME\_SYNC and RX\_CLOCK is connected to TX\_CLOCK.

### 25.7.9 Interrupt

Most bits in SR have a corresponding bit in interrupt management registers.

The SSC can be programmed to generate an interrupt when it detects an event. The interrupt is controlled by writing IER (Interrupt Enable Register) and IDR (Interrupt Disable Register) These registers enable and disable, respectively, the corresponding interrupt by setting and clearing the corresponding bit in IMR (Interrupt Mask Register), which controls the generation of interrupts by asserting the SSC interrupt line connected to the interrupt controller.



Figure 25-16. Interrupt Block Diagram

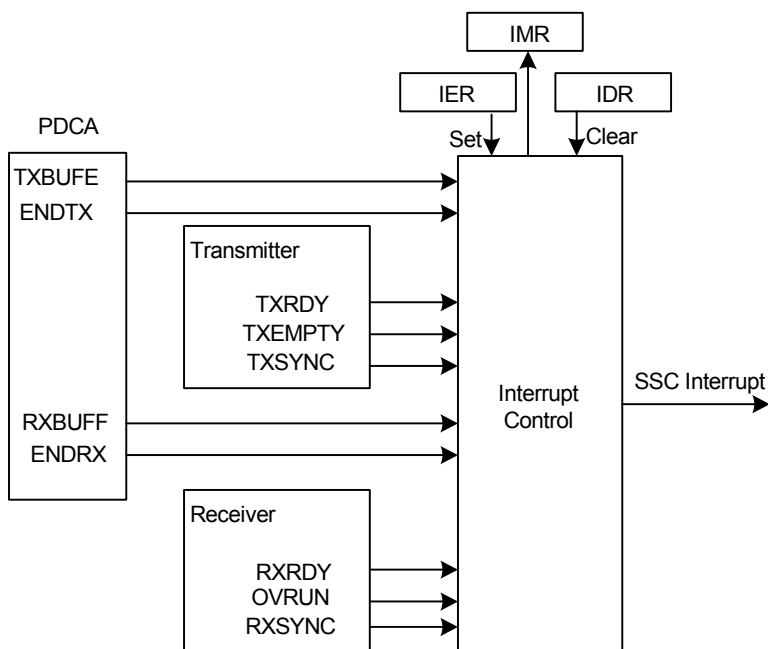

## 25.8 SSC Application Examples

The SSC can support several serial communication modes used in audio or high speed serial links. Some standard applications are shown in the following figures. All serial link applications supported by the SSC are not listed here.

Figure 25-17. Audio Application Block Diagram

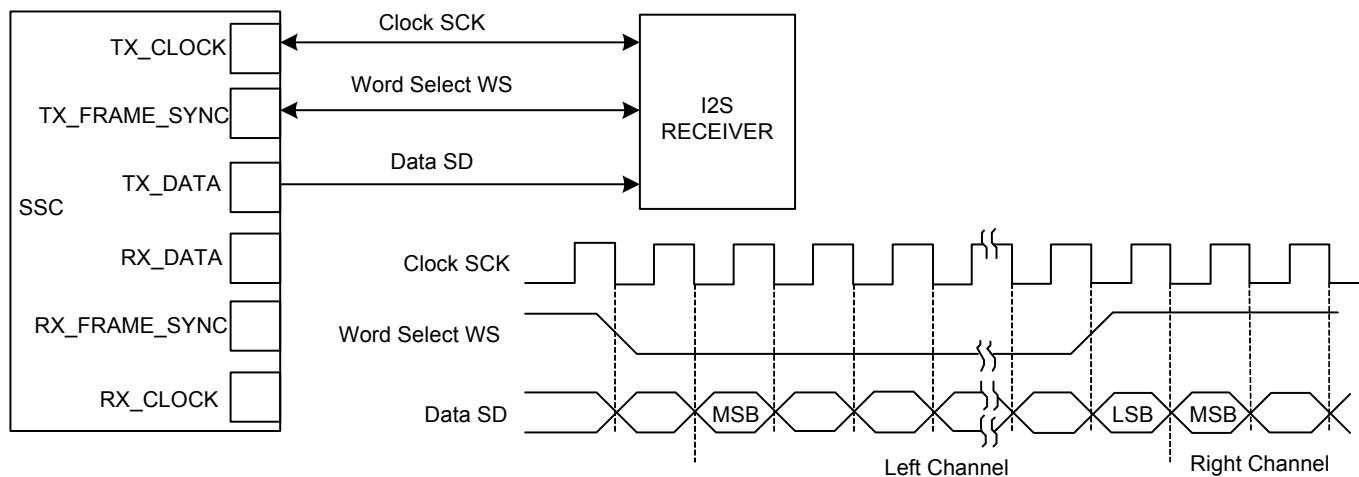

Figure 25-18. Codec Application Block Diagram

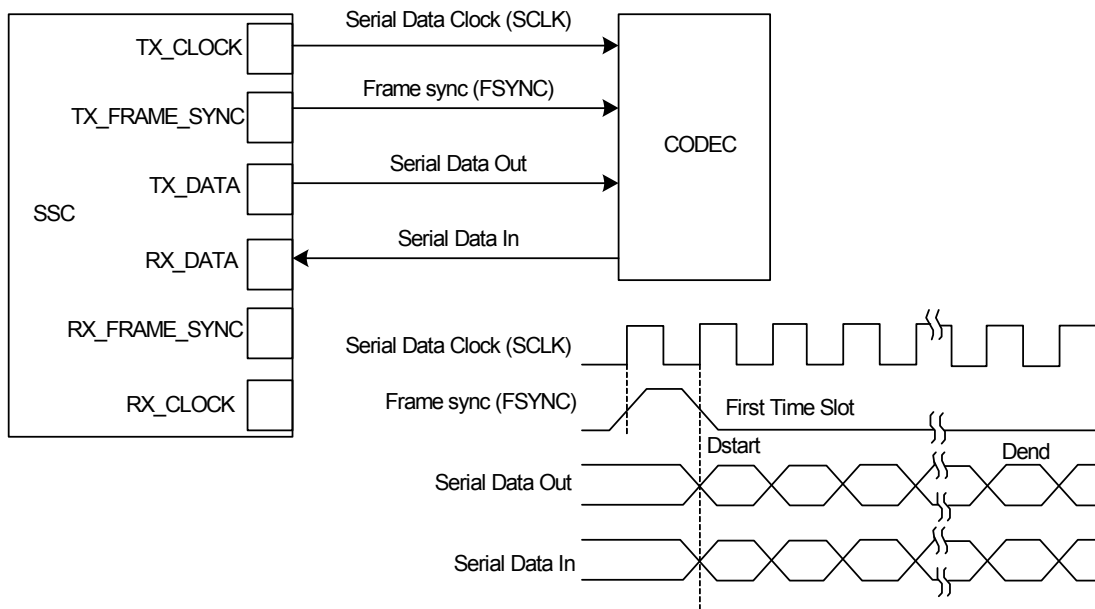
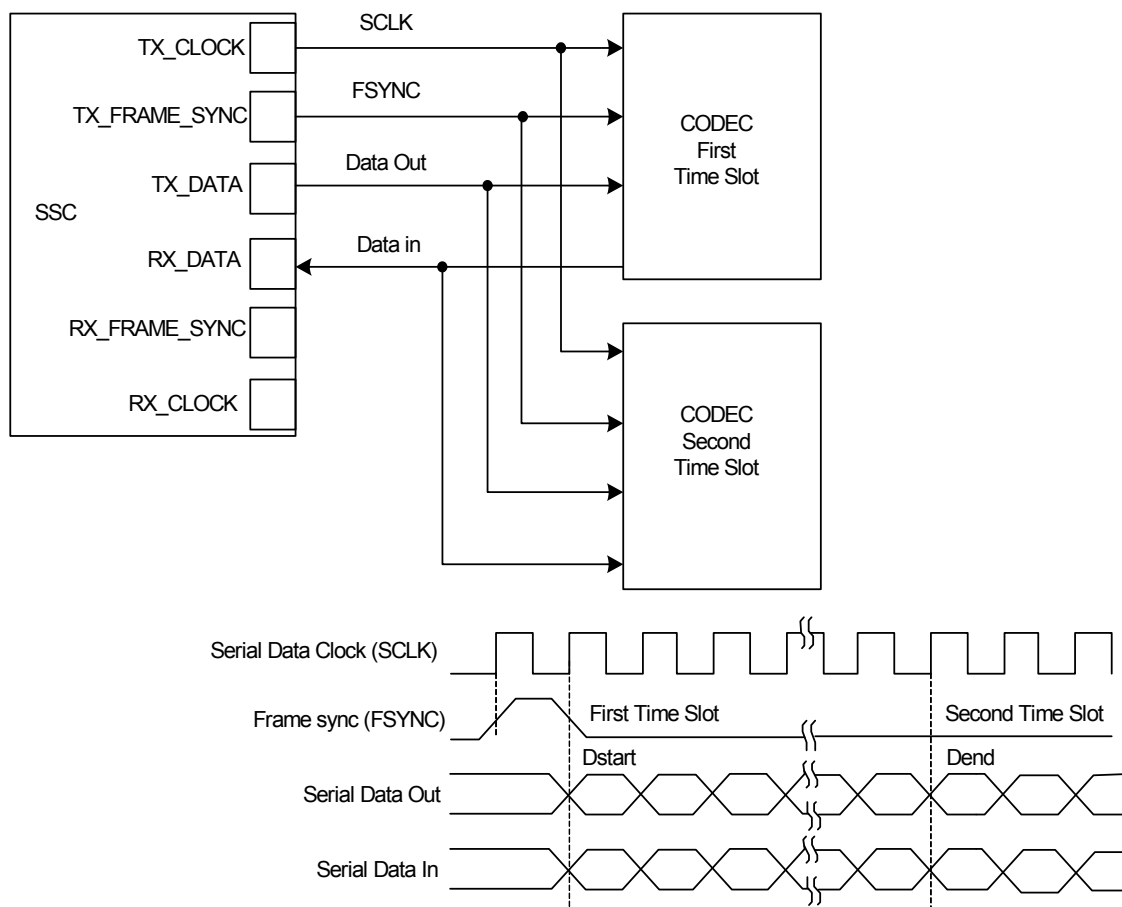

Figure 25-19. Time Slot Application Block Diagram



## 25.9 User Interface

**Table 25-4.** Register Mapping

Offset	Register	Register Name	Access	Reset
0x0	Control Register	CR	Write	–
0x4	Clock Mode Register	CMR	Read/Write	0x0
0x8	Reserved	–	–	–
0xC	Reserved	–	–	–
0x10	Receive Clock Mode Register	RCMR	Read/Write	0x0
0x14	Receive Frame Mode Register	RFMR	Read/Write	0x0
0x18	Transmit Clock Mode Register	TCMR	Read/Write	0x0
0x1C	Transmit Frame Mode Register	TFMR	Read/Write	0x0
0x20	Receive Holding Register	RHR	Read	0x0
0x24	Transmit Holding Register	THR	Write	–
0x28	Reserved	–	–	–
0x2C	Reserved	–	–	–
0x30	Receive Sync. Holding Register	RSHR	Read	0x0
0x34	Transmit Sync. Holding Register	TSHR	Read/Write	0x0
0x38	Receive Compare 0 Register	RC0R	Read/Write	0x0
0x3C	Receive Compare 1 Register	RC1R	Read/Write	0x0
0x40	Status Register	SR	Read	0x000000CC
0x44	Interrupt Enable Register	IER	Write	–
0x48	Interrupt Disable Register	IDR	Write	–
0x4C	Interrupt Mask Register	IMR	Read	0x0
0x50-0xFC	Reserved	–	–	–

## 25.9.1 Control Register

**Name:** CR  
**Access Type:** Write-only  
**Offset:** 0x00  
**Reset value:** -

31	30	29	28	27	26	25	24
-	-	-	-	-	-	-	-
23	22	21	20	19	18	17	16
-	-	-	-	-	-	-	-
15	14	13	12	11	10	9	8
SWRST	-	-	-	-	-	TXDIS	TXEN
7	6	5	4	3	2	1	0
-	-	-	-	-	-	RXDIS	RXEN

- **SWRST: Software Reset**

0: No effect.  
 1: Performs a software reset. Has priority on any other bit in CR.

- **TXDIS: Transmit Disable**

0: No effect.  
 1: Disables Transmit. If a character is currently being transmitted, disables at end of current character transmission.

- **TXEN: Transmit Enable**

0: No effect.  
 1: Enables Transmit if TXDIS is not set.

- **RXDIS: Receive Disable**

0: No effect.  
 1: Disables Receive. If a character is currently being received, disables at end of current character reception.

- **RXEN: Receive Enable**

0: No effect.  
 1: Enables Receive if RXDIS is not set.

## 25.9.2 Clock Mode Register

**Name:** CMR  
**Access Type:** Read/Write  
**Offset:** 0x04  
**Reset value:** 0x00000000

31	30	29	28	27	26	25	24
-	-	-	-	-	-	-	-
23	22	21	20	19	18	17	16
-	-	-	-	-	-	-	-
15	14	13	12	11	10	9	8
-	-	-	-	DIV			
7	6	5	4	3	2	1	0
DIV							

- DIV: Clock Divider**

0: The Clock Divider is not active.

Any Other Value: The Divided Clock equals the Master Clock divided by 2 times DIV. The maximum bit rate is  $CLK\_SSC/2$ . The minimum bit rate is  $CLK\_SSC/2 \times 4095 = CLK\_SSC/8190$ .

## 25.9.3 Receive Clock Mode Register

**Name:** RCMR  
**Access Type:** Read/Write  
**Offset:** 0x10  
**Reset value:** 0x00000000

31	30	29	28	27	26	25	24
PERIOD							
23	22	21	20	19	18	17	16
STTDLY							
15	14	13	12	11	10	9	8
-		-		STOP		START	
7	6	5	4	3	2	1	0
CKG		CKI		CKO		CKS	

- PERIOD: Receive Period Divider Selection**

This field selects the divider to apply to the selected Receive Clock in order to generate a new Frame Sync Signal. If 0, no PERIOD signal is generated. If not 0, a PERIOD signal is generated each 2 x (PERIOD+1) Receive Clock.

- STTDLY: Receive Start Delay**

If STTDLY is not 0, a delay of STTDLY clock cycles is inserted between the start event and the actual start of reception. When the Receiver is programmed to start synchronously with the Transmitter, the delay is also applied.

Note: It is very important that STTDLY be set carefully. If STTDLY must be set, it should be done in relation to TAG (Receive Sync Data) reception.

- STOP: Receive Stop Selection**

0: After completion of a data transfer when starting with a Compare 0, the receiver stops the data transfer and waits for a new compare 0.

1: After starting a receive with a Compare 0, the receiver operates in a continuous mode until a Compare 1 is detected.

- START: Receive Start Selection**

START	Receive Start
0x0	Continuous, as soon as the receiver is enabled, and immediately after the end of transfer of the previous data.
0x1	Transmit start
0x2	Detection of a low level on RX_FRAME_SYNC signal
0x3	Detection of a high level on RX_FRAME_SYNC signal
0x4	Detection of a falling edge on RX_FRAME_SYNC signal
0x5	Detection of a rising edge on RX_FRAME_SYNC signal
0x6	Detection of any level change on RX_FRAME_SYNC signal
0x7	Detection of any edge on RX_FRAME_SYNC signal
0x8	Compare 0
0x9-0xF	Reserved



• **CKG: Receive Clock Gating Selection**

CKG	Receive Clock Gating
0x0	None, continuous clock
0x1	Receive Clock enabled only if RX_FRAME_SYNC Low
0x2	Receive Clock enabled only if RX_FRAME_SYNC High
0x3	Reserved

• **CKI: Receive Clock Inversion**

0: The data inputs (Data and Frame Sync signals) are sampled on Receive Clock falling edge. The Frame Sync signal output is shifted out on Receive Clock rising edge.

1: The data inputs (Data and Frame Sync signals) are sampled on Receive Clock rising edge. The Frame Sync signal output is shifted out on Receive Clock falling edge.

CKI affects only the Receive Clock and not the output clock signal.

• **CKO: Receive Clock Output Mode Selection**

CKO	Receive Clock Output Mode	RX_CLOCK pin
0x0	None	Input-only
0x1	Continuous Receive Clock	Output
0x2	Receive Clock only during data transfers	Output
0x3-0x7	Reserved	

• **CKS: Receive Clock Selection**

CKS	Selected Receive Clock
0x0	Divided Clock
0x1	TX_CLOCK Clock signal
0x2	RX_CLOCK pin
0x3	Reserved

## 25.9.4 Receive Frame Mode Register

**Name:** RFMR  
**Access Type:** Read/Write  
**Offset:** 0x14  
**Reset value:** 0x00000000

31	30	29	28	27	26	25	24	
FSLENHI				-	-	-	FSEDGE	
23	22	21	20	19	18	17	16	
-	FSOS			FSLEN				
15	14	13	12	11	10	9	8	
-	-	-	-	DATNB				
7	6	5	4	3	2	1	0	
MSBF	-	LOOP	DATLEN					

- **FSLENHI: Receive Frame Sync Length High part**

The four MSB of the FSLEN bitfield.

- **FSEDGE: Frame Sync Edge Detection**

Determines which edge on Frame Sync will generate the interrupt RXSYN in the SSC Status Register.

FSEDGE	Frame Sync Edge Detection
0x0	Positive Edge Detection
0x1	Negative Edge Detection

- **FSOS: Receive Frame Sync Output Selection**

FSOS	Selected Receive Frame Sync Signal	RX_FRAME_SYNC Pin
0x0	None	Input-only
0x1	Negative Pulse	Output
0x2	Positive Pulse	Output
0x3	Driven Low during data transfer	Output
0x4	Driven High during data transfer	Output
0x5	Toggling at each start of data transfer	Output
0x6-0x7	Reserved	Undefined

- **FSLEN: Receive Frame Sync Length**

This field defines the length of the Receive Frame Sync Signal and the number of bits sampled and stored in the Receive Sync Data Register. When this mode is selected by the START field in the Receive Clock Mode Register, it also determines the length of the sampled data to be compared to the Compare 0 or Compare 1 register. Note: The four most significant bits for this bitfield are in the FSLENHI bitfield.

Pulse length is equal to  $(\{FSLENHI, FSLEN\} + 1)$  Receive Clock periods. Thus, if  $\{FSLENHI, FSLEN\}$  is 0, the Receive Frame Sync signal is generated during one Receive Clock period.

- **DATNB: Data Number per Frame**



This field defines the number of data words to be received after each transfer start, which is equal to (DATNB + 1).

- **MSBF: Most Significant Bit First**

0: The lowest significant bit of the data register is sampled first in the bit stream.

1: The most significant bit of the data register is sampled first in the bit stream.

- **LOOP: Loop Mode**

0: Normal operating mode.

1: RX\_DATA is driven by TX\_DATA, RX\_FRAME\_SYNC is driven by TX\_FRAME\_SYNC and TX\_CLOCK drives RX\_CLOCK.

- **DATLEN: Data Length**

0: Forbidden value (1-bit data length not supported).

Any other value: The bit stream contains DATLEN + 1 data bits. Moreover, it defines the transfer size performed by the PDCA assigned to the Receiver. If DATLEN is lower or equal to 7, data transfers are in bytes. If DATLEN is between 8 and 15 (included), half-words are transferred, and for any other value, 32-bit words are transferred.

## 25.9.5 Transmit Clock Mode Register

**Name:** TCMR  
**Access Type:** Read/Write  
**Offset:** 0x18  
**Reset value:** 0x00000000

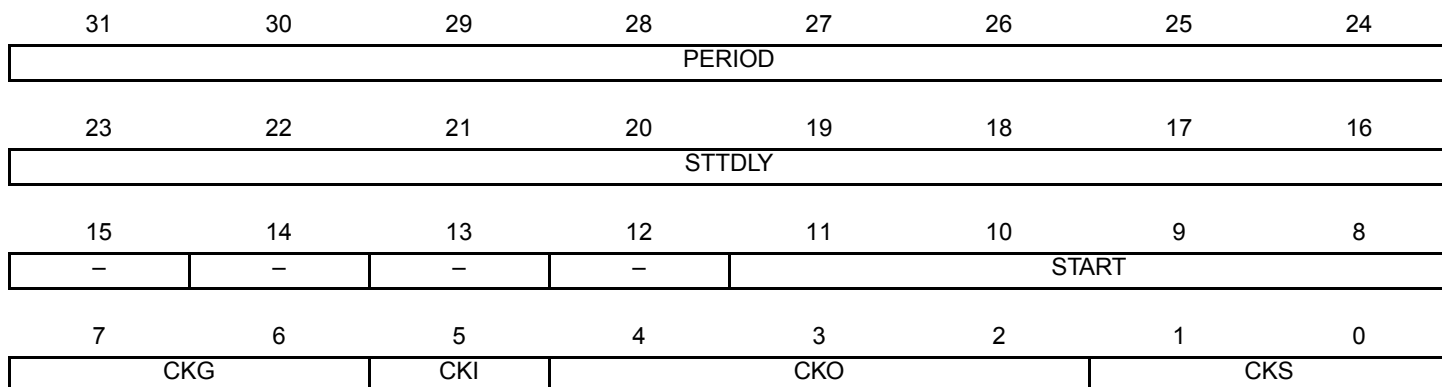

- **PERIOD: Transmit Period Divider Selection**

This field selects the divider to apply to the selected Transmit Clock to generate a new Frame Sync Signal. If 0, no period signal is generated. If not 0, a period signal is generated at each 2 x (PERIOD+1) Transmit Clock.

- **STTDLY: Transmit Start Delay**

If STTDLY is not 0, a delay of STTDLY clock cycles is inserted between the start event and the actual start of transmission of data. When the Transmitter is programmed to start synchronously with the Receiver, the delay is also applied.

Note: STTDLY must be set carefully. If STTDLY is too short in respect to TAG (Transmit Sync Data) emission, data is emitted instead of the end of TAG.

- **START: Transmit Start Selection**

START	Transmit Start
0x0	Continuous, as soon as a word is written in the THR Register (if Transmit is enabled), and immediately after the end of transfer of the previous data.
0x1	Receive start
0x2	Detection of a low level on TX_FRAME_SYNC signal
0x3	Detection of a high level on TX_FRAME_SYNC signal
0x4	Detection of a falling edge on TX_FRAME_SYNC signal
0x5	Detection of a rising edge on TX_FRAME_SYNC signal
0x6	Detection of any level change on TX_FRAME_SYNC signal
0x7	Detection of any edge on TX_FRAME_SYNC signal
0x8 - 0xF	Reserved

• **CKG: Transmit Clock Gating Selection**

CKG	Transmit Clock Gating
0x0	None, continuous clock
0x1	Transmit Clock enabled only if TX_FRAME_SYNC Low
0x2	Transmit Clock enabled only if TX_FRAME_SYNC High
0x3	Reserved

• **CKI: Transmit Clock Inversion**

0: The data outputs (Data and Frame Sync signals) are shifted out on Transmit Clock falling edge. The Frame sync signal input is sampled on Transmit clock rising edge.

1: The data outputs (Data and Frame Sync signals) are shifted out on Transmit Clock rising edge. The Frame sync signal input is sampled on Transmit clock falling edge.

CKI affects only the Transmit Clock and not the output clock signal.

• **CKO: Transmit Clock Output Mode Selection**

CKO	Transmit Clock Output Mode	TX_CLOCK pin
0x0	None	Input-only
0x1	Continuous Transmit Clock	Output
0x2	Transmit Clock only during data transfers	Output
0x3-0x7	Reserved	

• **CKS: Transmit Clock Selection**

CKS	Selected Transmit Clock
0x0	Divided Clock
0x1	RX_CLOCK Clock signal
0x2	TX_CLOCK Pin
0x3	Reserved

## 25.9.6 Transmit Frame Mode Register

**Name:** TFMR  
**Access Type:** Read/Write  
**Offset:** 0x1C  
**Reset value:** 0x00000000

31	30	29	28	27	26	25	24
FSLENHI				-	-	-	FSEDGE
23	22	21	20	19	18	17	16
FSDEN	FSOS			FSLEN			
15	14	13	12	11	10	9	8
-	-	-	-	DATNB			
7	6	5	4	3	2	1	0
MSBF	-	DATDEF	DATLEN				

- **FSLENHI: Transmit Frame Sync Length High part**

The four MSB of the FSLEN bitfield.

- **FSEDGE: Frame Sync Edge Detection**

Determines which edge on frame sync will generate the interrupt TXSYN (Status Register).

FSEDGE	Frame Sync Edge Detection
0x0	Positive Edge Detection
0x1	Negative Edge Detection

- **FSDEN: Frame Sync Data Enable**

0: The TX\_DATA line is driven with the default value during the Transmit Frame Sync signal.

1: TSHR value is shifted out during the transmission of the Transmit Frame Sync signal.

- **FSOS: Transmit Frame Sync Output Selection**

FSOS	Selected Transmit Frame Sync Signal	TX_FRAME_SYNC Pin
0x0	None	Input-only
0x1	Negative Pulse	Output
0x2	Positive Pulse	Output
0x3	Driven Low during data transfer	Output
0x4	Driven High during data transfer	Output
0x5	Toggling at each start of data transfer	Output
0x6-0x7	Reserved	Undefined

- **FSLEN: Transmit Frame Sync Length**

This field defines the length of the Transmit Frame Sync signal and the number of bits shifted out from the Transmit Sync Data Register if FSDEN is 1. Note: The four most significant bits for this bitfield are in the FSLENHI bitfield.

Pulse length is equal to  $(\{FSLENHI,FSLEN\} + 1)$  Transmit Clock periods, i.e., the pulse length can range from 1 to 16 Transmit Clock periods. If  $\{FSLENHI,FSLEN\}$  is 0, the Transmit Frame Sync signal is generated during one Transmit Clock period.

- **DATNB: Data Number per frame**

This field defines the number of data words to be transferred after each transfer start, which is equal to  $(DATNB + 1)$ .

- **MSBF: Most Significant Bit First**

0: The lowest significant bit of the data register is shifted out first in the bit stream.

1: The most significant bit of the data register is shifted out first in the bit stream.

- **DATDEF: Data Default Value**

This bit defines the level driven on the TX\_DATA pin while out of transmission. Note that if the pin is defined as multi-drive by the PIO Controller, the pin is enabled only if the SCC TX\_DATA output is 1.

- **DATLEN: Data Length**

0: Forbidden value (1-bit data length not supported).

Any other value: The bit stream contains  $DATLEN + 1$  data bits. Moreover, it defines the transfer size performed by the PDCA assigned to the Transmit. If DATLEN is lower or equal to 7, data transfers are bytes, if DATLEN is between 8 and 15 (included), half-words are transferred, and for any other value, 32-bit words are transferred.

## 25.9.7 SSC Receive Holding Register

**Name:** RHR  
**Access Type:** Read-only  
**Offset:** 0x20  
**Reset value:** 0x00000000

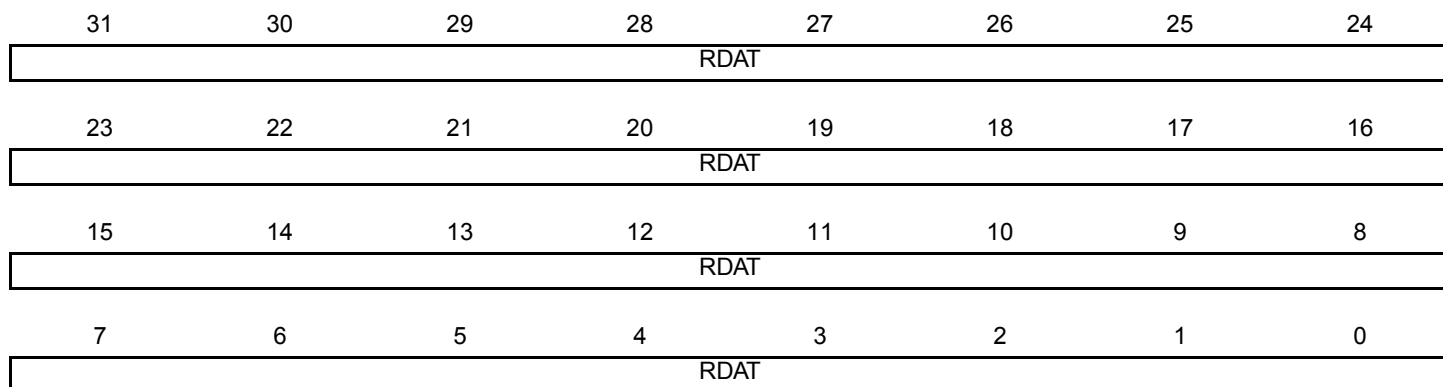

- **RDAT: Receive Data**

Right aligned regardless of the number of data bits defined by DATLEN in RFMR.

**25.9.8 Transmit Holding Register**

**Name:** THR  
**Access Type:** Write-only  
**Offset:** 0x24  
**Reset value:** -

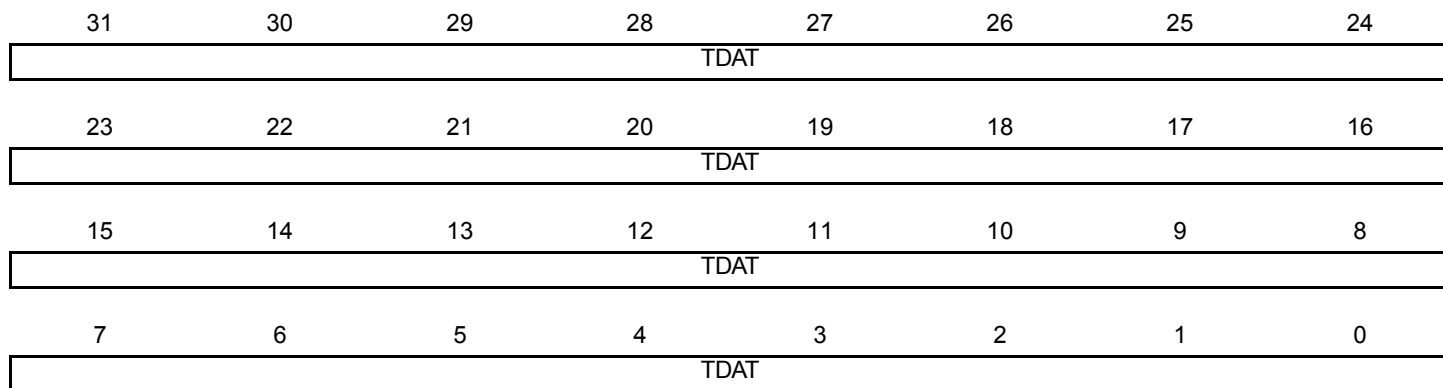

- **TDAT: Transmit Data**

Right aligned regardless of the number of data bits defined by DATLEN in TFMR.

## 25.9.9 Receive Synchronization Holding Register

**Name:** RSHR  
**Access Type:** Read-only  
**Offset:** 0x30  
**Reset value:** 0x00000000

31	30	29	28	27	26	25	24
-	-	-	-	-	-	-	-
23	22	21	20	19	18	17	16
-	-	-	-	-	-	-	-
15	14	13	12	11	10	9	8
RSDAT							
7	6	5	4	3	2	1	0
RSDAT							

- **RSDAT: Receive Synchronization Data**



**25.9.10 Transmit Synchronization Holding Register**

**Name:** TSHR  
**Access Type:** Read/Write  
**Offset:** 0x34  
**Reset value:** 0x00000000

31	30	29	28	27	26	25	24
–	–	–	–	–	–	–	–
23	22	21	20	19	18	17	16
–	–	–	–	–	–	–	–
15	14	13	12	11	10	9	8
TSDAT							
7	6	5	4	3	2	1	0
TSDAT							

- **TSDAT: Transmit Synchronization Data**

## 25.9.11 Receive Compare 0 Register

**Name:** RC0R  
**Access Type:** Read/Write  
**Offset:** 0x38  
**Reset value:** 0x00000000

31	30	29	28	27	26	25	24
-	-	-	-	-	-	-	-
23	22	21	20	19	18	17	16
-	-	-	-	-	-	-	-
15	14	13	12	11	10	9	8
CP0							
7	6	5	4	3	2	1	0
CP0							

- **CP0: Receive Compare Data 0**

## 25.9.12 Receive Compare 1 Register

**Name:** RC1R  
**Access Type:** Read/Write  
**Offset:** 0x3C  
**Reset value:** 0x00000000

31	30	29	28	27	26	25	24
-	-	-	-	-	-	-	-
23	22	21	20	19	18	17	16
-	-	-	-	-	-	-	-
15	14	13	12	11	10	9	8
CP1							
7	6	5	4	3	2	1	0
CP1							

- CP1: Receive Compare Data 1

## 25.9.13 Status Register

**Name:** SR  
**Access Type:** Read-only  
**Offset:** 0x40  
**Reset value:** 0x000000CC

31	30	29	28	27	26	25	24
–	–	–	–	–	–	–	–
23	22	21	20	19	18	17	16
–	–	–	–	–	–	RXEN	TXEN
15	14	13	12	11	10	9	8
–	–	–	–	RXSYN	TXSYN	CP1	CP0
7	6	5	4	3	2	1	0
RXBUFF	ENDRX	OVRUN	RXRDY	TXBUFE	ENDTX	TXEMPTY	TXRDY

- **RXEN: Receive Enable**

0: Receive is disabled.

1: Receive is enabled.

- **TXEN: Transmit Enable**

0: Transmit is disabled.

1: Transmit is enabled.

- **RXSYN: Receive Sync**

0: An Rx Sync has not occurred since the last read of the Status Register.

1: An Rx Sync has occurred since the last read of the Status Register.

- **TXSYN: Transmit Sync**

0: A Tx Sync has not occurred since the last read of the Status Register.

1: A Tx Sync has occurred since the last read of the Status Register.

- **CP1: Compare 1**

0: A compare 1 has not occurred since the last read of the Status Register.

1: A compare 1 has occurred since the last read of the Status Register.

- **CP0: Compare 0**

0: A compare 0 has not occurred since the last read of the Status Register.

1: A compare 0 has occurred since the last read of the Status Register.

- **RXBUFF: Receive Buffer Full**

0: RCR or RNCR have a value other than 0.

1: Both RCR and RNCR have a value of 0.

- **ENDRX: End of Reception**

0: Data is written on the Receive Counter Register or Receive Next Counter Register.

1: End of PDCA transfer when Receive Counter Register has arrived at zero.

- **OVRUN: Receive Overrun**

0: No data has been loaded in RHR while previous data has not been read since the last read of the Status Register.

1: Data has been loaded in RHR while previous data has not yet been read since the last read of the Status Register.

- **RXRDY: Receive Ready**

0: RHR is empty.

1: Data has been received and loaded in RHR.

- **TXBUFE: Transmit Buffer Empty**

0: TCR or TNCR have a value other than 0.

1: Both TCR and TNCR have a value of 0.

- **ENDTX: End of Transmission**

0: The register TCR has not reached 0 since the last write in TCR or TNCR.

1: The register TCR has reached 0 since the last write in TCR or TNCR.

- **TXEMPTY: Transmit Empty**

0: Data remains in THR or is currently transmitted from TSR.

1: Last data written in THR has been loaded in TSR and last data loaded in TSR has been transmitted.

- **TXRDY: Transmit Ready**

0: Data has been loaded in THR and is waiting to be loaded in the Transmit Shift Register (TSR).

1: THR is empty.

## 25.9.14 Interrupt Enable Register

**Name:** IER

**Access Type:** Write-only

**Offset:** 0x44

**Reset value:** -

31	30	29	28	27	26	25	24
-	-	-	-	-	-	-	-
23	22	21	20	19	18	17	16
-	-	-	-	-	-	-	-
15	14	13	12	11	10	9	8
-	-	-	-	RXSYN	TXSYN	CP1	CP0
7	6	5	4	3	2	1	0
RXBUFF	ENDRX	OVRUN	RXRDY	TXBUFE	ENDTX	TXEMPTY	TXRDY

- **RXSYN: Rx Sync Interrupt Enable**

0: No effect.

1: Enables the Rx Sync Interrupt.

- **TXSYN: Tx Sync Interrupt Enable**

0: No effect.

1: Enables the Tx Sync Interrupt.

- **CP1: Compare 1 Interrupt Enable**

0: No effect.

1: Enables the Compare 1 Interrupt.

- **CP0: Compare 0 Interrupt Enable**

0: No effect.

1: Enables the Compare 0 Interrupt.

- **RXBUFF: Receive Buffer Full Interrupt Enable**

0: No effect.

1: Enables the Receive Buffer Full Interrupt.

- **ENDRX: End of Reception Interrupt Enable**

0: No effect.

1: Enables the End of Reception Interrupt.

- **OVRUN: Receive Overrun Interrupt Enable**

0: No effect.

1: Enables the Receive Overrun Interrupt.

- **RXRDY: Receive Ready Interrupt Enable**

0: No effect.

1: Enables the Receive Ready Interrupt.

- **TXBUFE: Transmit Buffer Empty Interrupt Enable**

0: No effect.

1: Enables the Transmit Buffer Empty Interrupt

- **ENDTX: End of Transmission Interrupt Enable**

0: No effect.

1: Enables the End of Transmission Interrupt.

- **TXEMPTY: Transmit Empty Interrupt Enable**

0: No effect.

1: Enables the Transmit Empty Interrupt.

- **TXRDY: Transmit Ready Interrupt Enable**

0: No effect.

1: Enables the Transmit Ready Interrupt.

## 25.9.15 Interrupt Disable Register

**Name:** IDR

**Access Type:** Write-only

**Offset:** 0x48

**Reset value:** -

31	30	29	28	27	26	25	24
-	-	-	-	-	-	-	-
23	22	21	20	19	18	17	16
-	-	-	-	-	-	-	-
15	14	13	12	11	10	9	8
-	-	-	-	RXSYN	TXSYN	CP1	CP0
7	6	5	4	3	2	1	0
RXBUFF	ENDRX	OVRUN	RXRDY	TXBUFE	ENDTX	TXEMPTY	TXRDY

- **RXSYN: Rx Sync Interrupt Enable**

0: No effect.

1: Disables the Rx Sync Interrupt.

- **TXSYN: Tx Sync Interrupt Enable**

0: No effect.

1: Disables the Tx Sync Interrupt.

- **CP1: Compare 1 Interrupt Disable**

0: No effect.

1: Disables the Compare 1 Interrupt.

- **CP0: Compare 0 Interrupt Disable**

0: No effect.

1: Disables the Compare 0 Interrupt.

- **RXBUFF: Receive Buffer Full Interrupt Disable**

0: No effect.

1: Disables the Receive Buffer Full Interrupt.

- **ENDRX: End of Reception Interrupt Disable**

0: No effect.

1: Disables the End of Reception Interrupt.

- **OVRUN: Receive Overrun Interrupt Disable**

0: No effect.

1: Disables the Receive Overrun Interrupt.

- **RXRDY: Receive Ready Interrupt Disable**

0: No effect.



1: Disables the Receive Ready Interrupt.

- **TXBUFE: Transmit Buffer Empty Interrupt Disable**

0: No effect.

1: Disables the Transmit Buffer Empty Interrupt.

- **ENDTX: End of Transmission Interrupt Disable**

0: No effect.

1: Disables the End of Transmission Interrupt.

- **TXEMPTY: Transmit Empty Interrupt Disable**

0: No effect.

1: Disables the Transmit Empty Interrupt.

- **TXRDY: Transmit Ready Interrupt Disable**

0: No effect.

1: Disables the Transmit Ready Interrupt.

## 25.9.16 Interrupt Mask Register

**Name:** IMR  
**Access Type:** Read-only  
**Offset:** 0x4C  
**Reset value:** 0x00000000

31	30	29	28	27	26	25	24
–	–	–	–	–	–	–	–
23	22	21	20	19	18	17	16
–	–	–	–	–	–	–	–
15	14	13	12	11	10	9	8
–	–	–	–	RXSYN	TXSYN	CP1	CP0
7	6	5	4	3	2	1	0
RXBUFF	ENDRX	OVRUN	RXRDY	TXBUFE	ENDTX	TXEMPTY	TXRDY

- **RXSYN: Rx Sync Interrupt Mask**

0: The Rx Sync Interrupt is disabled.  
 1: The Rx Sync Interrupt is enabled.

- **TXSYN: Tx Sync Interrupt Mask**

0: The Tx Sync Interrupt is disabled.  
 1: The Tx Sync Interrupt is enabled.

- **CP1: Compare 1 Interrupt Mask**

0: The Compare 1 Interrupt is disabled.  
 1: The Compare 1 Interrupt is enabled.

- **CP0: Compare 0 Interrupt Mask**

0: The Compare 0 Interrupt is disabled.  
 1: The Compare 0 Interrupt is enabled.

- **RXBUFF: Receive Buffer Full Interrupt Mask**

0: The Receive Buffer Full Interrupt is disabled.  
 1: The Receive Buffer Full Interrupt is enabled.

- **ENDRX: End of Reception Interrupt Mask**

0: The End of Reception Interrupt is disabled.  
 1: The End of Reception Interrupt is enabled.

- **OVRUN: Receive Overrun Interrupt Mask**

0: The Receive Overrun Interrupt is disabled.  
 1: The Receive Overrun Interrupt is enabled.

- **RXRDY: Receive Ready Interrupt Mask**

0: The Receive Ready Interrupt is disabled.

## 26. Universal Synchronous/Asynchronous Receiver/Transmitter (USART)

Rev. 4.0.0.2

### 26.1 Features

- Programmable Baud Rate Generator
- 5- to 9-bit Full-duplex Synchronous or Asynchronous Serial Communications
  - 1, 1.5 or 2 Stop Bits in Asynchronous Mode or 1 or 2 Stop Bits in Synchronous Mode
  - Parity Generation and Error Detection
  - Framing Error Detection, Overrun Error Detection
  - MSB- or LSB-first
  - Optional Break Generation and Detection
  - By 8 or by 16 Over-sampling Receiver Frequency
  - Optional Hardware Handshaking RTS-CTS
  - Receiver Time-out and Transmitter Timeguard
  - Optional Multidrop Mode with Address Generation and Detection
- RS485 with Driver Control Signal
- ISO7816, T = 0 or T = 1 Protocols for Interfacing with Smart Cards
  - NACK Handling, Error Counter with Repetition and Iteration Limit
- IrDA Modulation and Demodulation
  - Communication at up to 115.2 Kbps
- SPI Mode
  - Master or Slave
  - Serial Clock Programmable Phase and Polarity
  - SPI Serial Clock (CLK) Frequency up to Internal Clock Frequency CLK\_USART/4
- Test Modes
  - Remote Loopback, Local Loopback, Automatic Echo
- Supports Connection of Two Peripheral DMA Controller Channels (PDC)
  - Offers Buffer Transfer without Processor Intervention

### 26.2 Overview

The Universal Synchronous Asynchronous Receiver Transceiver (USART) provides one full duplex universal synchronous asynchronous serial link. Data frame format is widely programmable (data length, parity, number of stop bits) to support a maximum of standards. The receiver implements parity error, framing error and overrun error detection. The receiver time-out enables handling variable-length frames and the transmitter timeguard facilitates communications with slow remote devices. Multidrop communications are also supported through address bit handling in reception and transmission.

The USART features three test modes: remote loopback, local loopback and automatic echo.

The USART supports specific operating modes providing interfaces on RS485 and SPI buses, with ISO7816 T = 0 or T = 1 smart card slots and infrared transceivers. The hardware handshaking feature enables an out-of-band flow control by automatic management of the pins RTS and CTS.

The USART supports the connection to the Peripheral DMA Controller, which enables data transfers to the transmitter and from the receiver. The PDC provides chained buffer management without any intervention of the processor.

### 26.3 Block Diagram

Figure 26-1. USART Block Diagram

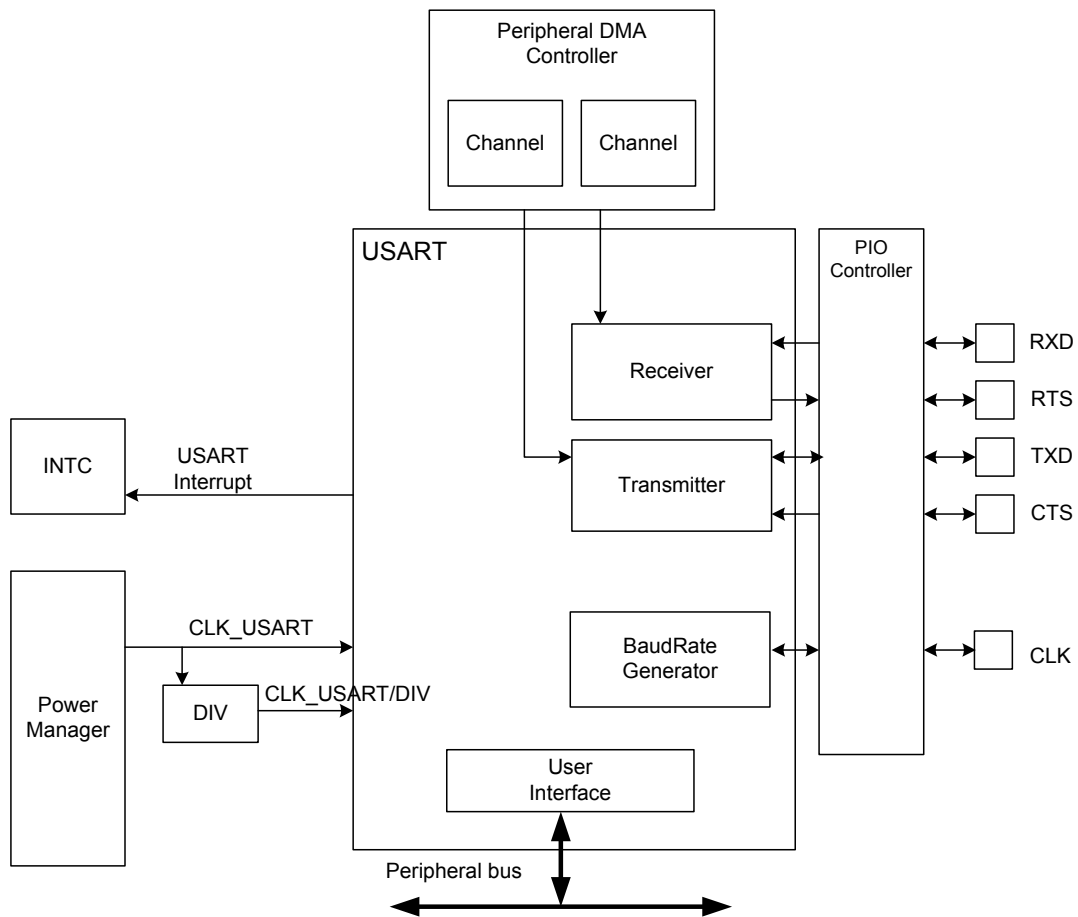

## 26.4 Application Block Diagram

Figure 26-2. Application Block Diagram

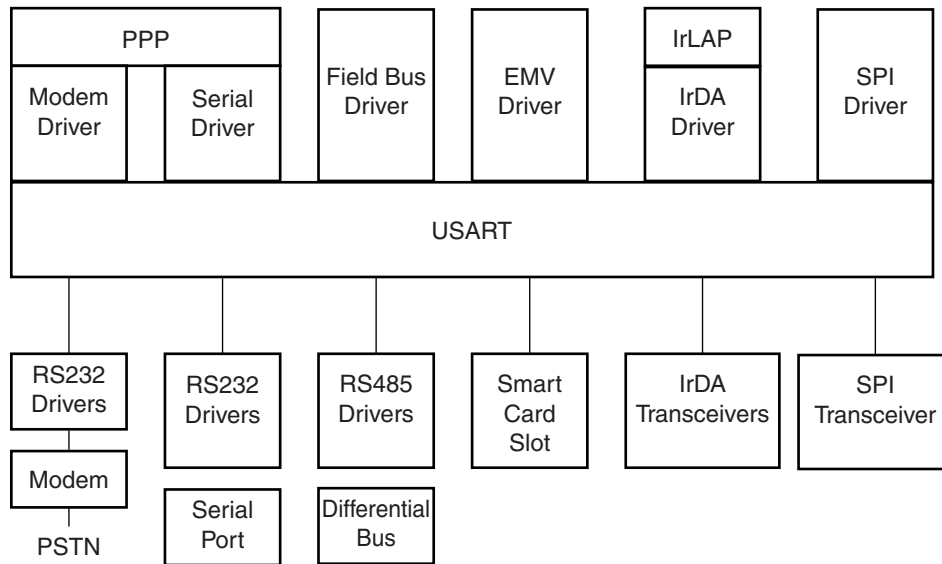

## 26.5 I/O Lines Description

Table 26-1. I/O Line Description

Name	Description	Type	Active Level
CLK	Serial Clock	I/O	
TXD	Transmit Serial Data or Master Out Slave In (MOSI) in SPI Master Mode or Master In Slave Out (MISO) in SPI Slave Mode	I/O	
RXD	Receive Serial Data or Master In Slave Out (MISO) in SPI Master Mode or Master Out Slave In (MOSI) in SPI Slave Mode	Input	
CTS	Clear to Send or Slave Select (NSS) in SPI Slave Mode	Input	Low
RTS	Request to Send or Slave Select (NSS) in SPI Master Mode	Output	Low

## 26.6 Product Dependencies

### 26.6.1 I/O Lines

The pins used for interfacing the USART may be multiplexed with the PIO lines. The programmer must first program the PIO controller to assign the desired USART pins to their peripheral function. If I/O lines of the USART are not used by the application, they can be used for other purposes by the PIO Controller.

To prevent the TXD line from falling when the USART is disabled, the use of an internal pull up is mandatory. If the hardware handshaking feature or Modem mode is used, the internal pull up on TXD must also be enabled.

### 26.6.2 Power Manager (PM)

The USART is not continuously clocked. The programmer must first enable the USART Clock in the Power Manager (PM) before using the USART. However, if the application does not require USART operations, the USART clock can be stopped when not needed and be restarted later. In this case, the USART will resume its operations where it left off.

Configuring the USART does not require the USART clock to be enabled.

### 26.6.3 Interrupt

The USART interrupt line is connected on one of the internal sources of the Advanced Interrupt Controller. Using the USART interrupt requires the INTC to be programmed first. Note that it is not recommended to use the USART interrupt line in edge sensitive mode.

## 26.7 Functional Description

The USART is capable of managing several types of serial synchronous or asynchronous communications.

It supports the following communication modes:

- 5- to 9-bit full-duplex asynchronous serial communication
  - MSB- or LSB-first
  - 1, 1.5 or 2 stop bits
  - Parity even, odd, marked, space or none
  - By 8 or by 16 over-sampling receiver frequency
  - Optional hardware handshaking
  - Optional break management
  - Optional multidrop serial communication
- High-speed 5- to 9-bit full-duplex synchronous serial communication
  - MSB- or LSB-first
  - 1 or 2 stop bits
  - Parity even, odd, marked, space or none
  - By 8 or by 16 over-sampling frequency
  - Optional hardware handshaking
  - Optional break management
  - Optional multidrop serial communication
- RS485 with driver control signal
- ISO7816, T0 or T1 protocols for interfacing with smart cards
  - NACK handling, error counter with repetition and iteration limit
- InfraRed IrDA Modulation and Demodulation
- **SPI Mode**
  - **Master or Slave**
  - **Serial Clock Programmable Phase and Polarity**
  - **SPI Serial Clock (CLK) Frequency up to Internal Clock Frequency CLK\_USART/4**
- Test modes
  - Remote loopback, local loopback, automatic echo



## 26.7.1 Baud Rate Generator

The Baud Rate Generator provides the bit period clock named the Baud Rate Clock to both the receiver and the transmitter.

The Baud Rate Generator clock source can be selected by setting the USCLKS field in the Mode Register (MR) between:

- the CLK\_USART
- a division of the CLK\_USART, the divider being product dependent, but generally set to 8
- the external clock, available on the CLK pin

The Baud Rate Generator is based upon a 16-bit divider, which is programmed with the CD field of the Baud Rate Generator Register (BRGR). If CD is programmed at 0, the Baud Rate Generator does not generate any clock. If CD is programmed at 1, the divider is bypassed and becomes inactive.

If the external CLK clock is selected, the duration of the low and high levels of the signal provided on the CLK pin must be longer than a CLK\_USART period. The frequency of the signal provided on CLK must be at least 4.5 times lower than CLK\_USART.

**Figure 26-3.** Baud Rate Generator

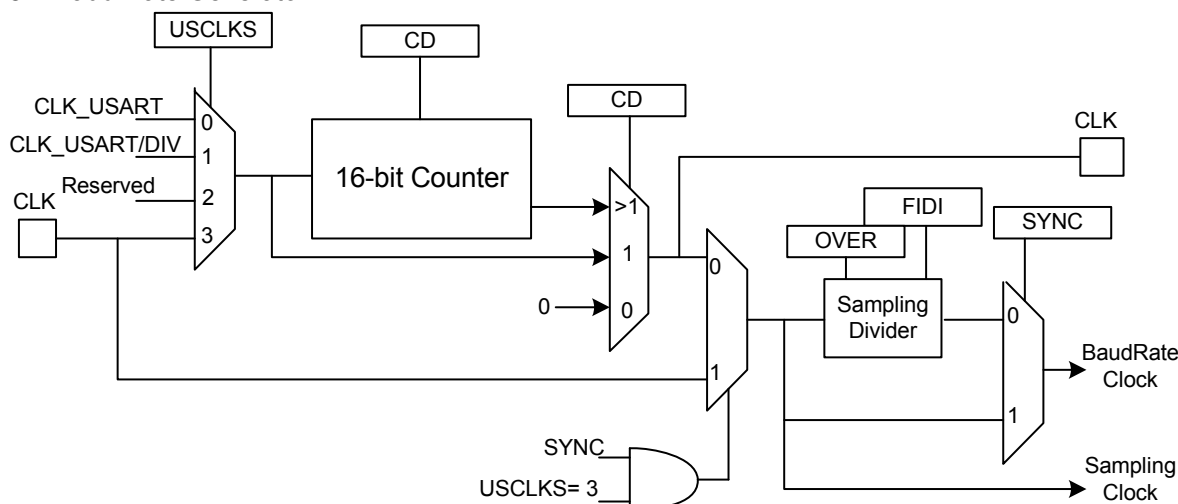

### 26.7.1.1 Baud Rate in Asynchronous Mode

If the USART is programmed to operate in asynchronous mode, the selected clock is first divided by CD, which is field programmed in the Baud Rate Generator Register (BRGR). The resulting clock is provided to the receiver as a sampling clock and then divided by 16 or 8, depending on the programming of the OVER bit in MR.

If OVER is set to 1, the receiver sampling is 8 times higher than the baud rate clock. If OVER is cleared, the sampling is performed at 16 times the baud rate clock.

The following formula performs the calculation of the Baud Rate.

$$Baudrate = \frac{SelectedClock}{(8(2 - Over)CD)}$$

This gives a maximum baud rate of CLK\_USART divided by 8, assuming that CLK\_USART is the highest possible clock and that OVER is programmed at 1.

## 26.7.1.2 Baud Rate Calculation Example

Table 26-2 on page 306 shows calculations of CD to obtain a baud rate at 38400 bauds for different source clock frequencies. This table also shows the actual resulting baud rate and the error.

**Table 26-2.** Baud Rate Example (OVER = 0)

Source Clock	Expected Baud Rate	Calculation Result	CD	Actual Baud Rate	Error
MHz	Bit/s			Bit/s	
3 686 400	38 400	6.00	6	38 400.00	0.00%
4 915 200	38 400	8.00	8	38 400.00	0.00%
5 000 000	38 400	8.14	8	39 062.50	1.70%
7 372 800	38 400	12.00	12	38 400.00	0.00%
8 000 000	38 400	13.02	13	38 461.54	0.16%
12 000 000	38 400	19.53	20	37 500.00	2.40%
12 288 000	38 400	20.00	20	38 400.00	0.00%
14 318 180	38 400	23.30	23	38 908.10	1.31%
14 745 600	38 400	24.00	24	38 400.00	0.00%
18 432 000	38 400	30.00	30	38 400.00	0.00%
24 000 000	38 400	39.06	39	38 461.54	0.16%
24 576 000	38 400	40.00	40	38 400.00	0.00%
25 000 000	38 400	40.69	40	38 109.76	0.76%
32 000 000	38 400	52.08	52	38 461.54	0.16%
32 768 000	38 400	53.33	53	38 641.51	0.63%
33 000 000	38 400	53.71	54	38 194.44	0.54%
40 000 000	38 400	65.10	65	38 461.54	0.16%
50 000 000	38 400	81.38	81	38 580.25	0.47%
60 000 000	38 400	97.66	98	38 265.31	0.35%
70 000 000	38 400	113.93	114	38 377.19	0.06%

The baud rate is calculated with the following formula:

$$BaudRate = (CLKUSART) / CD \times 16$$

The baud rate error is calculated with the following formula. It is not recommended to work with an error higher than 5%.

$$Error = 1 - \left( \frac{ExpectedBaudRate}{ActualBaudRate} \right)$$

## 26.7.1.3 Fractional Baud Rate in Asynchronous Mode

The Baud Rate generator previously defined is subject to the following limitation: the output frequency changes by only integer multiples of the reference frequency. An approach to this problem is to integrate a fractional N clock generator that has a high resolution. The generator architecture is modified to obtain Baud Rate changes by a fraction of the reference source clock. This fractional part is programmed with the FP field in the Baud Rate Generator Register (BRGR). If FP is not 0, the fractional part is activated. The resolution is one eighth of the clock divider. This feature is only available when using USART normal mode. The fractional Baud Rate is calculated using the following formula:

$$Baudrate = \frac{SelectedClock}{\left(8(2 - Over)\left(CD + \frac{FP}{8}\right)\right)}$$

The modified architecture is presented below:

**Figure 26-4.** Fractional Baud Rate Generator

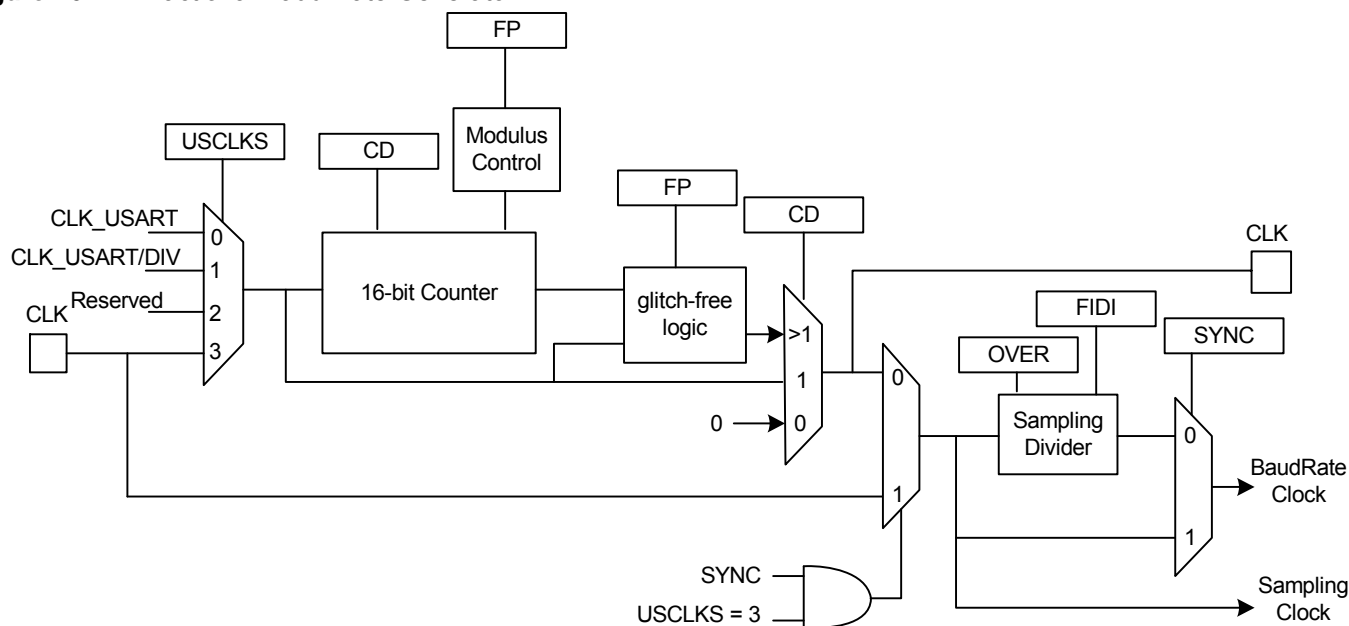

## 26.7.1.4 Baud Rate in Synchronous Mode or SPI Mode

If the USART is programmed to operate in synchronous mode, the selected clock is simply divided by the field CD in BRGR.

$$BaudRate = \frac{SelectedClock}{CD}$$

In synchronous mode, if the external clock is selected (USCLKS = 3), the clock is provided directly by the signal on the USART CLK pin. No division is active. The value written in BRGR

has no effect. The external clock frequency must be at least 4.5 times lower than the system clock.

When either the external clock CLK or the internal clock divided (CLK\_USART/DIV) is selected, the value programmed in CD must be even if the user has to ensure a 50:50 mark/space ratio on the CLK pin. If the internal clock CLK\_USART is selected, the Baud Rate Generator ensures a 50:50 duty cycle on the CLK pin, even if the value programmed in CD is odd.

### 26.7.1.5 Baud Rate in ISO 7816 Mode

The ISO7816 specification defines the bit rate with the following formula:

$$B = \frac{Di}{Fi} \times f$$

where:

- B is the bit rate
- Di is the bit-rate adjustment factor
- Fi is the clock frequency division factor
- f is the ISO7816 clock frequency (Hz)

Di is a binary value encoded on a 4-bit field, named DI, as represented in [Table 26-3 on page 308](#).

**Table 26-3.** Binary and Decimal Values for Di

DI field	0001	0010	0011	0100	0101	0110	1000	1001
Di (decimal)	1	2	4	8	16	32	12	20

Fi is a binary value encoded on a 4-bit field, named FI, as represented in [Table 26-4 on page 308](#).

**Table 26-4.** Binary and Decimal Values for Fi

FI field	0000	0001	0010	0011	0100	0101	0110	1001	1010	1011	1100	1101
Fi (decimal)	372	372	558	744	1116	1488	1860	512	768	1024	1536	2048

[Table 26-5 on page 308](#) shows the resulting Fi/Di Ratio, which is the ratio between the ISO7816 clock and the baud rate clock.

**Table 26-5.** Possible Values for the Fi/Di Ratio

Fi/Di	372	558	774	1116	1488	1806	512	768	1024	1536	2048
1	372	558	744	1116	1488	1860	512	768	1024	1536	2048
2	186	279	372	558	744	930	256	384	512	768	1024
4	93	139.5	186	279	372	465	128	192	256	384	512
8	46.5	69.75	93	139.5	186	232.5	64	96	128	192	256
16	23.25	34.87	46.5	69.75	93	116.2	32	48	64	96	128
32	11.62	17.43	23.25	34.87	46.5	58.13	16	24	32	48	64
12	31	46.5	62	93	124	155	42.66	64	85.33	128	170.6
20	18.6	27.9	37.2	55.8	74.4	93	25.6	38.4	51.2	76.8	102.4

If the USART is configured in ISO7816 Mode, the clock selected by the USCLKS field in the Mode Register (MR) is first divided by the value programmed in the field CD in the Baud Rate

Generator Register (BRGR). The resulting clock can be provided to the CLK pin to feed the smart card clock inputs. This means that the CLKO bit can be set in MR.

This clock is then divided by the value programmed in the FI\_DI\_RATIO field in the FI\_DI\_Ratio register (FIDI). This is performed by the Sampling Divider, which performs a division by up to 2047 in ISO7816 Mode. The non-integer values of the Fi/Di Ratio are not supported and the user must program the FI\_DI\_RATIO field to a value as close as possible to the expected value.

The FI\_DI\_RATIO field resets to the value 0x174 (372 in decimal) and is the most common divider between the ISO7816 clock and the bit rate (Fi = 372, Di = 1).

Figure 26-5 on page 309 shows the relation between the Elementary Time Unit, corresponding to a bit time, and the ISO 7816 clock.

**Figure 26-5.** Elementary Time Unit (ETU)

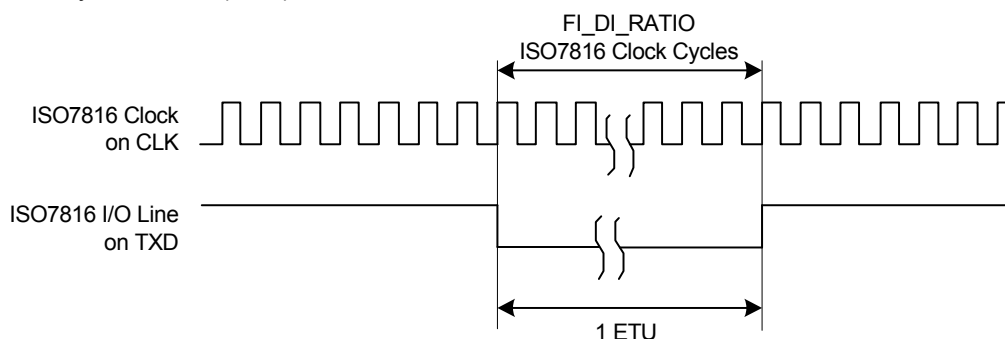

## 26.7.2 Receiver and Transmitter Control

After reset, the receiver is disabled. The user must enable the receiver by setting the RXEN bit in the Control Register (CR). However, the receiver registers can be programmed before the receiver clock is enabled.

After reset, the transmitter is disabled. The user must enable it by setting the TXEN bit in the Control Register (CR). However, the transmitter registers can be programmed before being enabled.

The Receiver and the Transmitter can be enabled together or independently.

At any time, the software can perform a reset on the receiver or the transmitter of the USART by setting the corresponding bit, RSTRX and RSTTX respectively, in the Control Register (CR). The software resets clear the status flag and reset internal state machines but the user interface configuration registers hold the value configured prior to software reset. Regardless of what the receiver or the transmitter is performing, the communication is immediately stopped.

The user can also independently disable the receiver or the transmitter by setting RXDIS and TXDIS respectively in CR. If the receiver is disabled during a character reception, the USART waits until the end of reception of the current character, then the reception is stopped. If the transmitter is disabled while it is operating, the USART waits the end of transmission of both the current character and character being stored in the Transmit Holding Register (THR). If a time-guard is programmed, it is handled normally.

## 26.7.3 Synchronous and Asynchronous Modes

### 26.7.3.1 Transmitter Operations

The transmitter performs the same in both synchronous and asynchronous operating modes (SYNC = 0 or SYNC = 1). One start bit, up to 9 data bits, one optional parity bit and up to two stop bits are successively shifted out on the TXD pin at each falling edge of the programmed serial clock.

The number of data bits is selected by the CHRL field and the MODE 9 bit in the Mode Register (MR). Nine bits are selected by setting the MODE 9 bit regardless of the CHRL field. The parity bit is set according to the PAR field in MR. The even, odd, space, marked or none parity bit can be configured. The MSBF field in MR configures which data bit is sent first. If written at 1, the most significant bit is sent first. At 0, the less significant bit is sent first. The number of stop bits is selected by the NBSTOP field in MR. The 1.5 stop bit is supported in asynchronous mode only.

**Figure 26-6.** Character Transmit

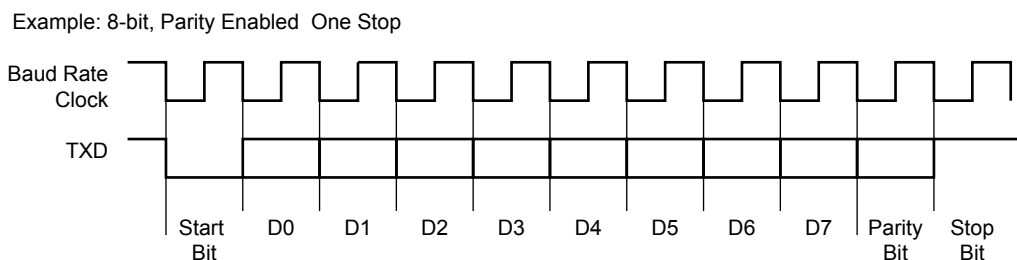

The characters are sent by writing in the Transmit Holding Register (THR). The transmitter reports two status bits in the Channel Status Register (CSR): TXRDY (Transmitter Ready), which indicates that THR is empty and TXEMPTY, which indicates that all the characters written in THR have been processed. When the current character processing is completed, the last character written in THR is transferred into the Shift Register of the transmitter and THR becomes empty, thus TXRDY rises.

Both TXRDY and TXEMPTY bits are low when the transmitter is disabled. Writing a character in THR while TXRDY is low has no effect and the written character is lost.

**Figure 26-7.** Transmitter Status

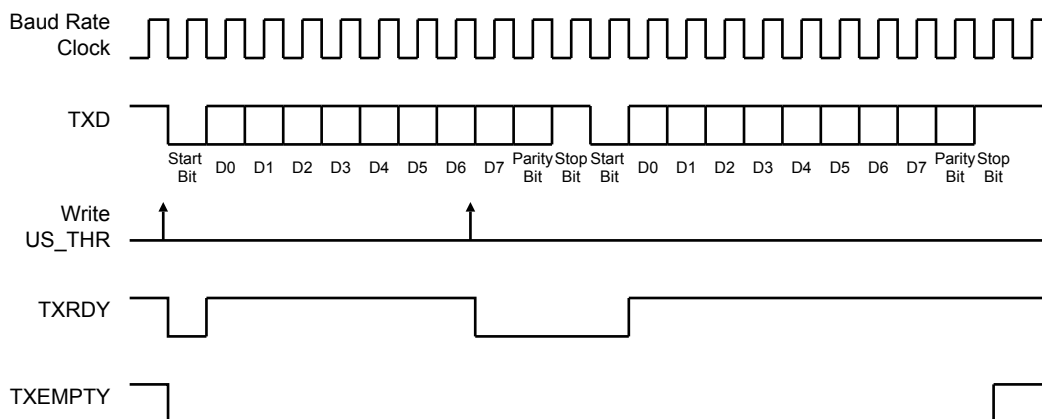

## 26.7.3.2 Manchester Encoder

When the Manchester encoder is in use, characters transmitted through the USART are encoded based on biphase Manchester II format. To enable this mode, set the MAN field in the MR register to 1. Depending on polarity configuration, a logic level (zero or one), is transmitted as a coded signal one-to-zero or zero-to-one. Thus, a transition always occurs at the midpoint of each bit time. It consumes more bandwidth than the original NRZ signal (2x) but the receiver has more error control since the expected input must show a change at the center of a bit cell. An example of Manchester encoded sequence is: the byte 0xB1 or 10110001 encodes to 10 01 10 10 01 01 01 10, assuming the default polarity of the encoder. [Figure 26-8 on page 311](#) illustrates this coding scheme.

**Figure 26-8.** NRZ to Manchester Encoding

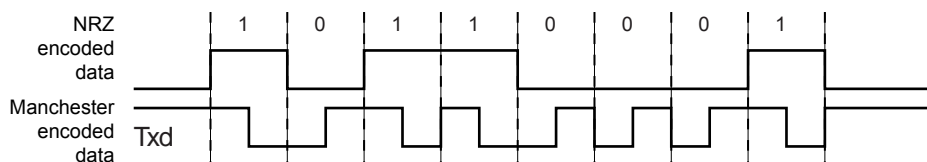

The Manchester encoded character can also be encapsulated by adding both a configurable preamble and a start frame delimiter pattern. Depending on the configuration, the preamble is a training sequence, composed of a pre-defined pattern with a programmable length from 1 to 15 bit times. If the preamble length is set to 0, the preamble waveform is not generated prior to any character. The preamble pattern is chosen among the following sequences: ALL\_ONE, ALL\_ZERO, ONE\_ZERO or ZERO\_ONE, writing the field TX\_PP in the MAN register, the field TX\_PL is used to configure the preamble length. [Figure 26-9 on page 312](#) illustrates and defines the valid patterns. To improve flexibility, the encoding scheme can be configured using the TX\_MPOL field in the MAN register. If the TX\_MPOL field is set to zero (default), a logic zero is encoded with a zero-to-one transition and a logic one is encoded with a one-to-zero transition. If the TX\_MPOL field is set to one, a logic one is encoded with a one-to-zero transition and a logic zero is encoded with a zero-to-one transition.

Figure 26-9. Preamble Patterns, Default Polarity Assumed

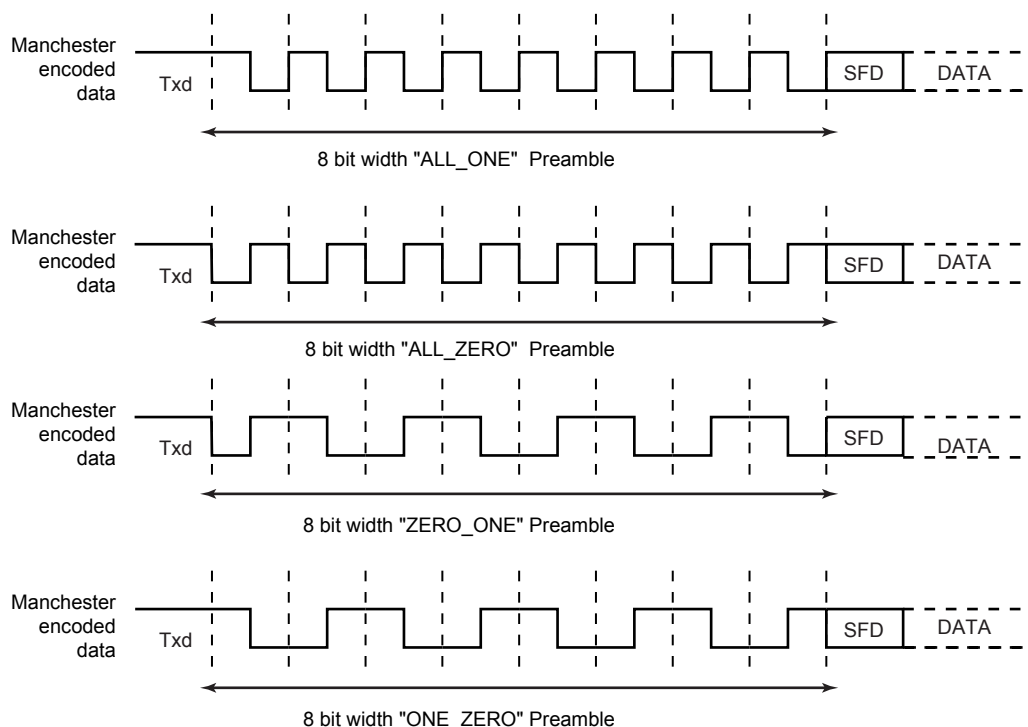

A start frame delimiter is to be configured using the ONEBIT field in the MR register. It consists of a user-defined pattern that indicates the beginning of a valid data. [Figure 26-10 on page 313](#) illustrates these patterns. If the start frame delimiter, also known as start bit, is one bit, (ONEBIT at 1), a logic zero is Manchester encoded and indicates that a new character is being sent serially on the line. If the start frame delimiter is a synchronization pattern also referred to as sync (ONEBIT at 0), a sequence of 3 bit times is sent serially on the line to indicate the start of a new character. The sync waveform is in itself an invalid Manchester waveform as the transition occurs at the middle of the second bit time. Two distinct sync patterns are used: the command sync and the data sync. The command sync has a logic one level for one and a half bit times, then a transition to logic zero for the second one and a half bit times. If the MODSYNC field in the MR register is set to 1, the next character is a command. If it is set to 0, the next character is a data. When direct memory access is used, the MODSYNC field can be immediately updated with a modified character located in memory. To enable this mode, VAR\_SYNC field in MR register must be set to 1. In this case, the MODSYNC field in MR is bypassed and the sync configuration is held in the TXSYNH in the THR register. The USART character format is modified and includes sync information.



Figure 26-10. Start Frame Delimiter

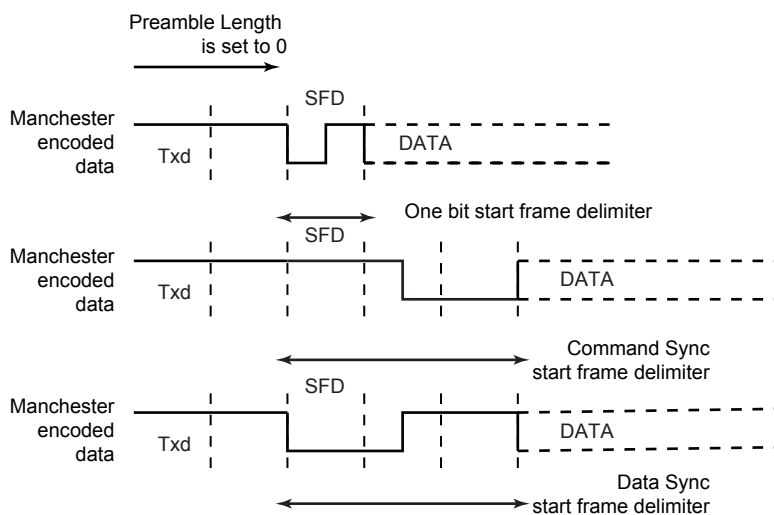

26.7.3.3 Drift Compensation

Drift compensation is available only in 16X oversampling mode. An hardware recovery system allows a larger clock drift. To enable the hardware system, the bit in the MAN register must be set. If the RXD edge is one 16X clock cycle from the expected edge, this is considered as normal jitter and no corrective actions is taken. If the RXD event is between 4 and 2 clock cycles before the expected edge, then the current period is shortened by one clock cycle. If the RXD event is between 2 and 3 clock cycles after the expected edge, then the current period is lengthened by one clock cycle. These intervals are considered to be drift and so corrective actions are automatically taken.

Figure 26-11. Bit Resynchronization

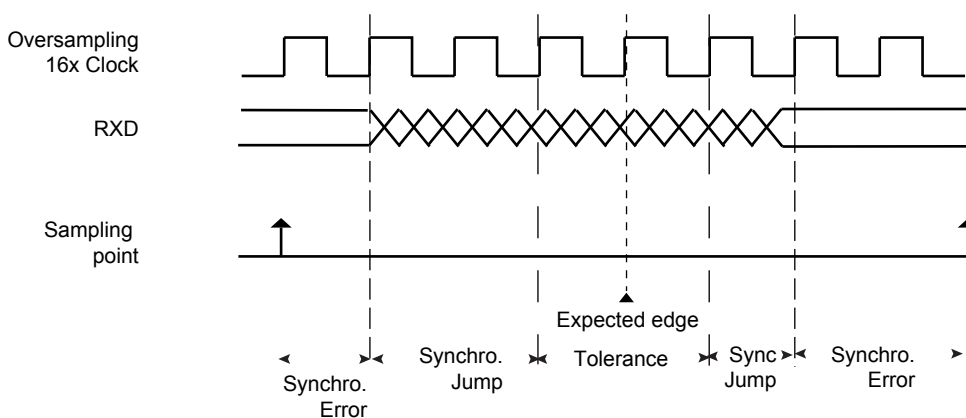

26.7.3.4 Asynchronous Receiver

If the USART is programmed in asynchronous operating mode (SYNC = 0), the receiver oversamples the RXD input line. The oversampling is either 16 or 8 times the Baud Rate clock, depending on the OVER bit in the Mode Register (MR).

The receiver samples the RXD line. If the line is sampled during one half of a bit time at 0, a start bit is detected and data, parity and stop bits are successively sampled on the bit rate clock.

If the oversampling is 16, (OVER at 0), a start is detected at the eighth sample at 0. Then, data bits, parity bit and stop bit are sampled on each 16 sampling clock cycle. If the oversampling is 8 (OVER at 1), a start bit is detected at the fourth sample at 0. Then, data bits, parity bit and stop bit are sampled on each 8 sampling clock cycle.

The number of data bits, first bit sent and parity mode are selected by the same fields and bits as the transmitter, i.e. respectively CHRL, MODE9, MSBF and PAR. For the synchronization mechanism **only**, the number of stop bits has no effect on the receiver as it considers only one stop bit, regardless of the field NBSTOP, so that resynchronization between the receiver and the transmitter can occur. Moreover, as soon as the stop bit is sampled, the receiver starts looking for a new start bit so that resynchronization can also be accomplished when the transmitter is operating with one stop bit.

Figure 26-12 on page 314 and Figure 26-13 on page 314 illustrate start detection and character reception when USART operates in asynchronous mode.

**Figure 26-12. Asynchronous Start Detection**

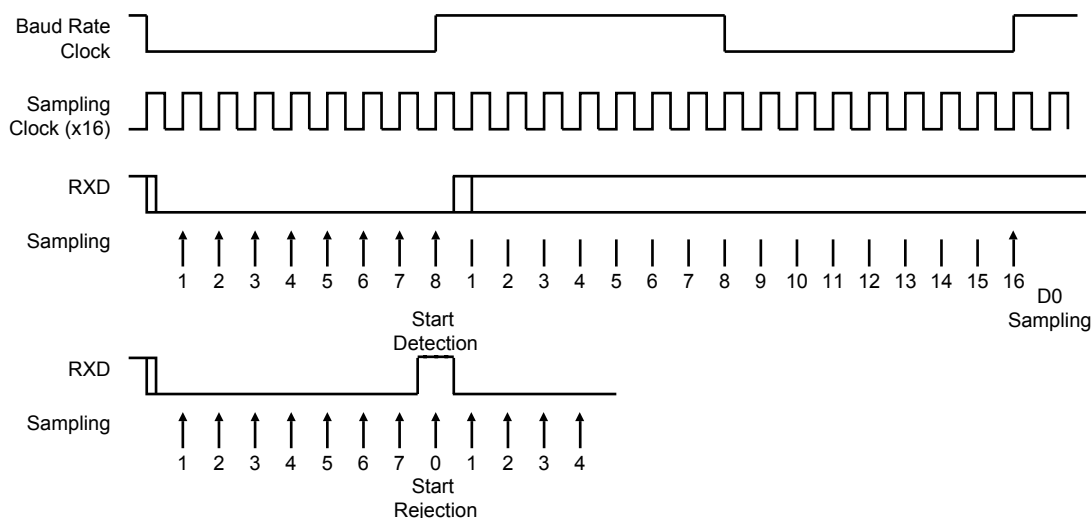

**Figure 26-13. Asynchronous Character Reception**

Example: 8-bit, Parity Enabled

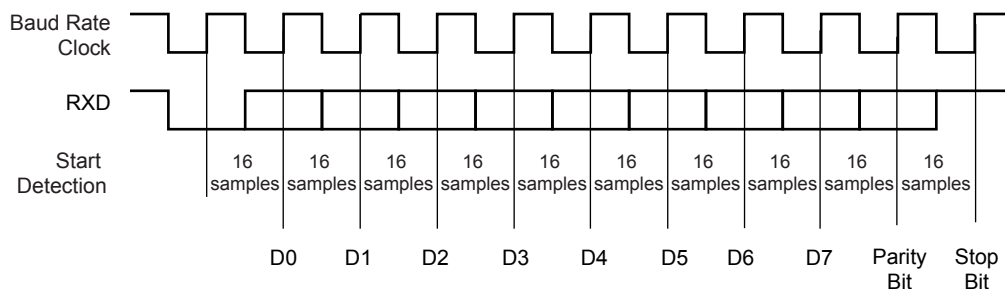

## 26.7.3.5 Manchester Decoder

When the MAN field in MR register is set to 1, the Manchester decoder is enabled. The decoder performs both preamble and start frame delimiter detection. One input line is dedicated to Manchester encoded input data.

An optional preamble sequence can be defined, its length is user-defined and totally independent of the emitter side. Use RX\_PL in MAN register to configure the length of the preamble sequence. If the length is set to 0, no preamble is detected and the function is disabled. In addition, the polarity of the input stream is programmable with RX\_MPOL field in MAN register. Depending on the desired application the preamble pattern matching is to be defined via the RX\_PP field in MAN. See [Figure 26-9 on page 312](#) for available preamble patterns.

Unlike preamble, the start frame delimiter is shared between Manchester Encoder and Decoder. So, if ONEBIT field is set to 1, only a zero encoded Manchester can be detected as a valid start frame delimiter. If ONEBIT is set to 0, only a sync pattern is detected as a valid start frame delimiter. Decoder operates by detecting transition on incoming stream. If RXD is sampled during one quarter of a bit time at zero, a start bit is detected. See [Figure 26-14 on page 315](#). The sample pulse rejection mechanism applies.

**Figure 26-14.** Asynchronous Start Bit Detection

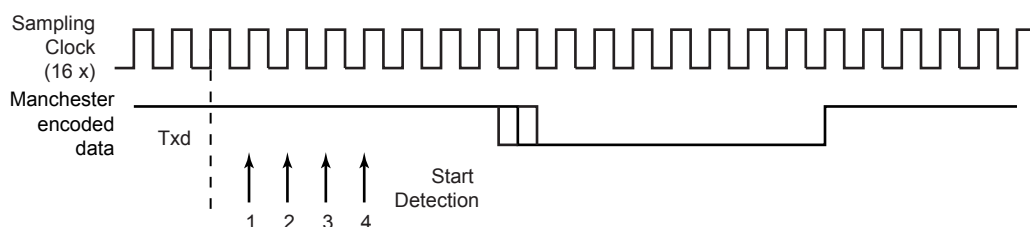

The receiver is activated and starts Preamble and Frame Delimiter detection, sampling the data at one quarter and then three quarters. If a valid preamble pattern or start frame delimiter is detected, the receiver continues decoding with the same synchronization. If the stream does not match a valid pattern or a valid start frame delimiter, the receiver re-synchronizes on the next valid edge. The minimum time threshold to estimate the bit value is three quarters of a bit time.

If a valid preamble (if used) followed with a valid start frame delimiter is detected, the incoming stream is decoded into NRZ data and passed to USART for processing. [Figure 26-15 on page 316](#) illustrates Manchester pattern mismatch. When incoming data stream is passed to the USART, the receiver is also able to detect Manchester code violation. A code violation is a lack of transition in the middle of a bit cell. In this case, MANE flag in CSR register is raised. It is cleared by writing the Control Register (CR) with the RSTSTA bit at 1. See [Figure 26-16 on page 316](#) for an example of Manchester error detection during data phase.

Figure 26-15. Preamble Pattern Mismatch

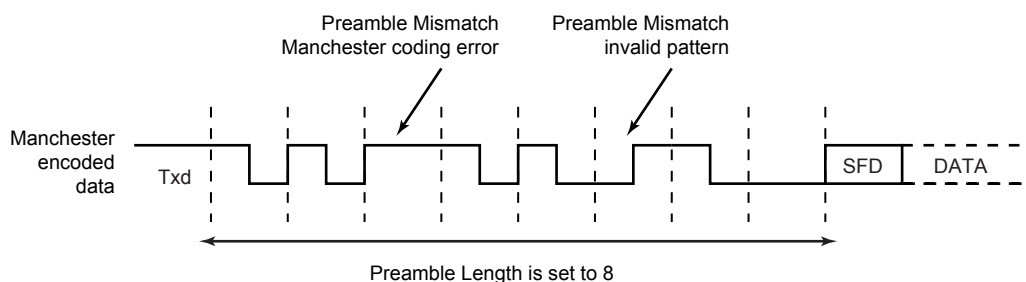
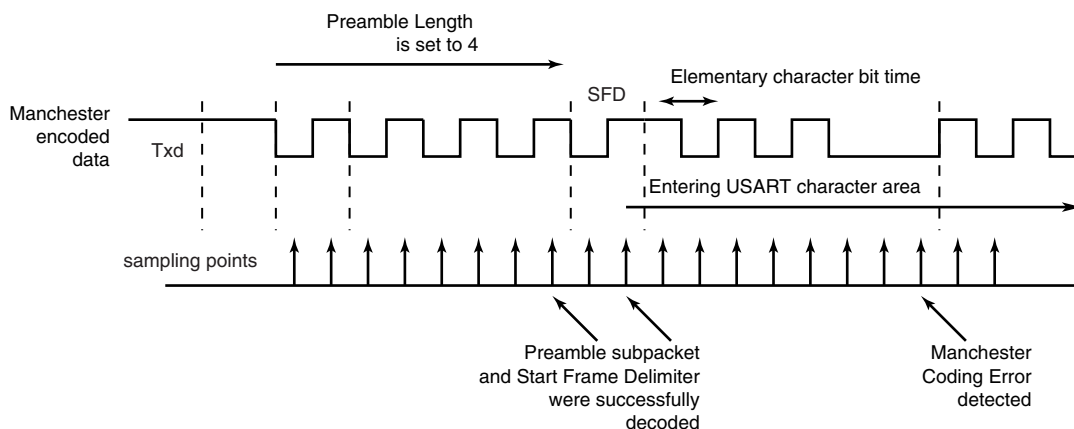

Figure 26-16. Manchester Error Flag



When the start frame delimiter is a sync pattern (ONEBIT field at 0), both command and data delimiter are supported. If a valid sync is detected, the received character is written as RXCHR field in the RHR register and the RXSYNH is updated. RXCHR is set to 1 when the received character is a command, and it is set to 0 if the received character is a data. This mechanism alleviates and simplifies the direct memory access as the character contains its own sync field in the same register.

As the decoder is setup to be used in unipolar mode, the first bit of the frame has to be a zero-to-one transition.

### 26.7.3.6 Radio Interface: Manchester Encoded USART Application

This section describes low data rate RF transmission systems and their integration with a Manchester encoded USART. These systems are based on transmitter and receiver ICs that support ASK and FSK modulation schemes.

The goal is to perform full duplex radio transmission of characters using two different frequency carriers. See the configuration in [Figure 26-17 on page 317](#).

Figure 26-17. Manchester Encoded Characters RF Transmission

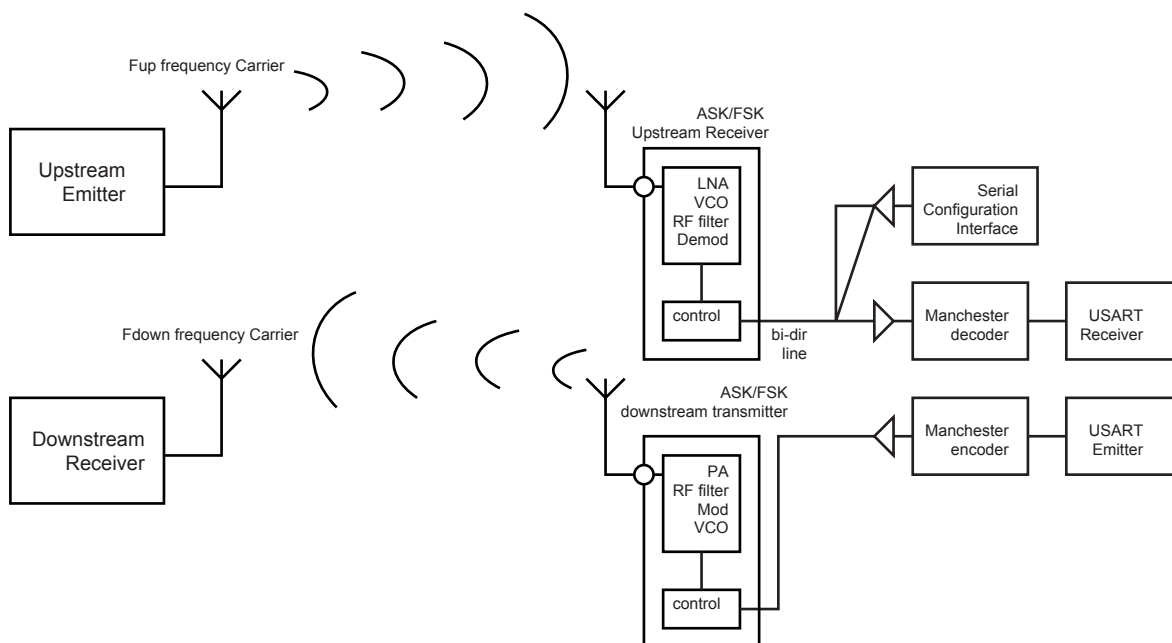

The USART module is configured as a Manchester encoder/decoder. Looking at the downstream communication channel, Manchester encoded characters are serially sent to the RF emitter. This may also include a user defined preamble and a start frame delimiter. Mostly, preamble is used in the RF receiver to distinguish between a valid data from a transmitter and signals due to noise. The Manchester stream is then modulated. See [Figure 26-18 on page 317](#) for an example of ASK modulation scheme. When a logic one is sent to the ASK modulator, the power amplifier, referred to as PA, is enabled and transmits an RF signal at downstream frequency. When a logic zero is transmitted, the RF signal is turned off. If the FSK modulator is activated, two different frequencies are used to transmit data. When a logic 1 is sent, the modulator outputs an RF signal at frequency  $F_0$  and switches to  $F_1$  if the data sent is a 0. See [Figure 26-19 on page 318](#).

From the receiver side, another carrier frequency is used. The RF receiver performs a bit check operation examining demodulated data stream. If a valid pattern is detected, the receiver switches to receiving mode. The demodulated stream is sent to the Manchester decoder. Because of bit checking inside RF IC, the data transferred to the microcontroller is reduced by a user-defined number of bits. The Manchester preamble length is to be defined in accordance with the RF IC configuration.

Figure 26-18. ASK Modulator Output

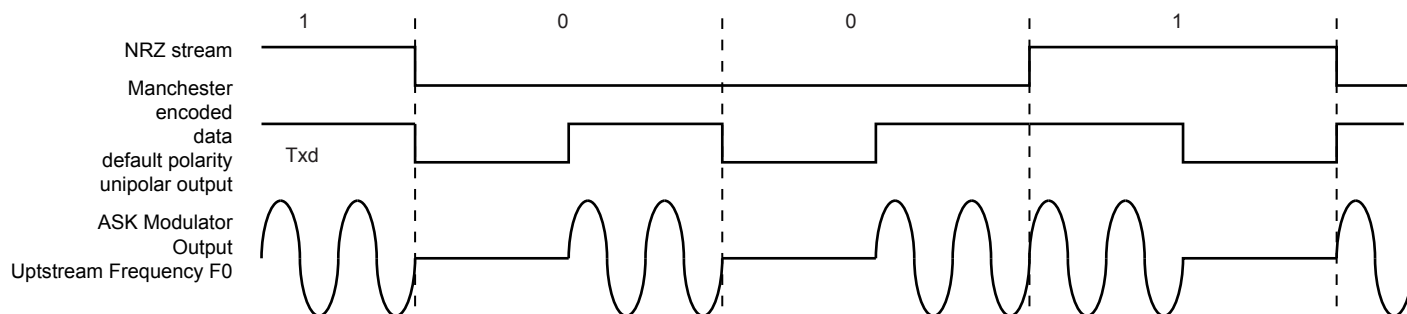

**Figure 26-19.** FSK Modulator Output

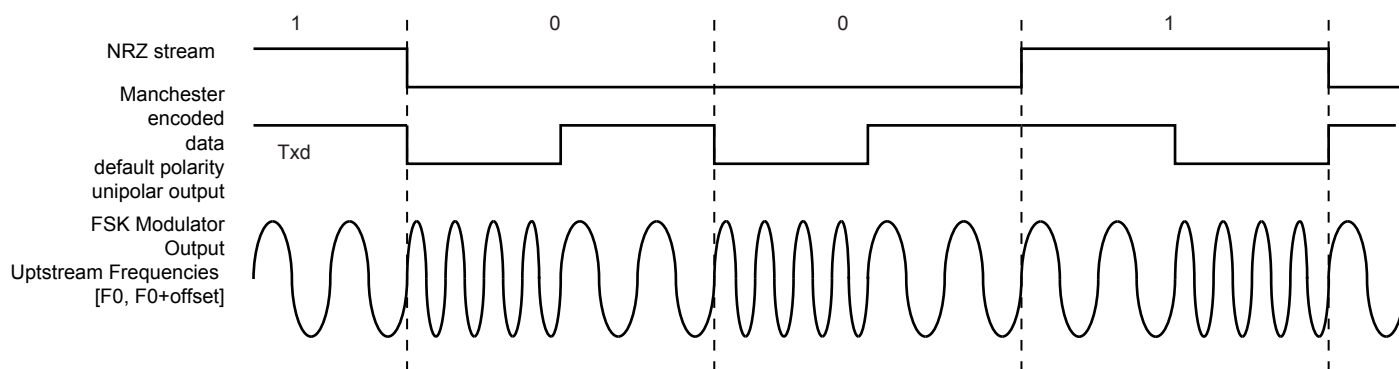

## 26.7.4 Synchronous Receiver

In synchronous mode (SYNC = 1), the receiver samples the RXD signal on each rising edge of the Baud Rate Clock. If a low level is detected, it is considered as a start. All data bits, the parity bit and the stop bits are sampled and the receiver waits for the next start bit. Synchronous mode operations provide a high speed transfer capability.

Configuration fields and bits are the same as in asynchronous mode.

[Figure 26-20 on page 318](#) illustrates a character reception in synchronous mode.

**Figure 26-20.** Synchronous Mode Character Reception

Example: 8-bit, Parity Enabled 1 Stop

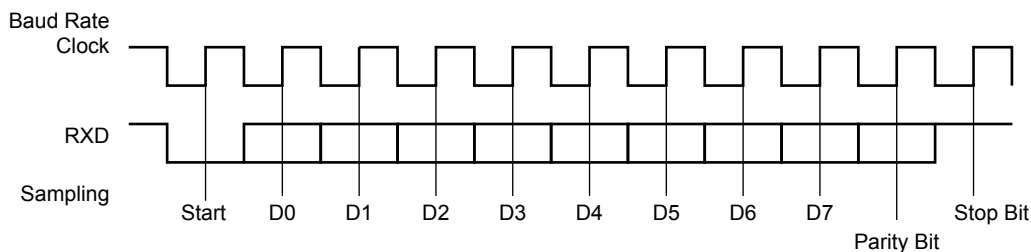

### 26.7.4.1 Receiver Operations

When a character reception is completed, it is transferred to the Receive Holding Register (RHR) and the RXRDY bit in the Status Register (CSR) rises. If a character is completed while the RXRDY is set, the OVRE (Overrun Error) bit is set. The last character is transferred into RHR and overwrites the previous one. The OVRE bit is cleared by writing the Control Register (CR) with the RSTSTA (Reset Status) bit at 1.

Figure 26-21. Receiver Status

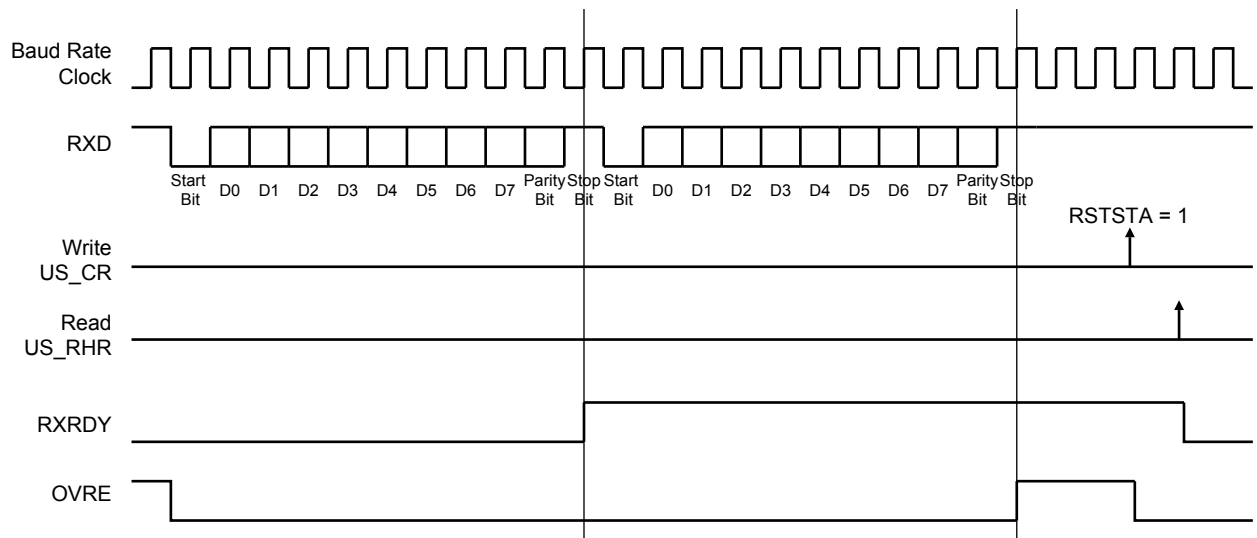

## 26.7.4.2 Parity

The USART supports five parity modes selected by programming the PAR field in the Mode Register (MR). The PAR field also enables the Multidrop mode, see ["Multidrop Mode" on page 321](#). Even and odd parity bit generation and error detection are supported.

If even parity is selected, the parity generator of the transmitter drives the parity bit at 0 if a number of 1s in the character data bit is even, and at 1 if the number of 1s is odd. Accordingly, the receiver parity checker counts the number of received 1s and reports a parity error if the sampled parity bit does not correspond. If odd parity is selected, the parity generator of the transmitter drives the parity bit at 1 if a number of 1s in the character data bit is even, and at 0 if the number of 1s is odd. Accordingly, the receiver parity checker counts the number of received 1s and reports a parity error if the sampled parity bit does not correspond. If the mark parity is used, the parity generator of the transmitter drives the parity bit at 1 for all characters. The receiver parity checker reports an error if the parity bit is sampled at 0. If the space parity is used, the parity generator of the transmitter drives the parity bit at 0 for all characters. The receiver parity checker reports an error if the parity bit is sampled at 1. If parity is disabled, the transmitter does not generate any parity bit and the receiver does not report any parity error.

[Table 26-6 on page 320](#) shows an example of the parity bit for the character 0x41 (character ASCII "A") depending on the configuration of the USART. Because there are two bits at 1, 1 bit is added when a parity is odd, or 0 is added when a parity is even.

**Table 26-6.** Parity Bit Examples

Character	Hexa	Binary	Parity Bit	Parity Mode
A	0x41	0100 0001	1	Odd
A	0x41	0100 0001	0	Even
A	0x41	0100 0001	1	Mark
A	0x41	0100 0001	0	Space
A	0x41	0100 0001	None	None

When the receiver detects a parity error, it sets the PARE (Parity Error) bit in the Channel Status Register (CSR). The PARE bit can be cleared by writing the Control Register (CR) with the RST-STA bit at 1. [Figure 26-22 on page 321](#) illustrates the parity bit status setting and clearing.



Figure 26-22. Parity Error

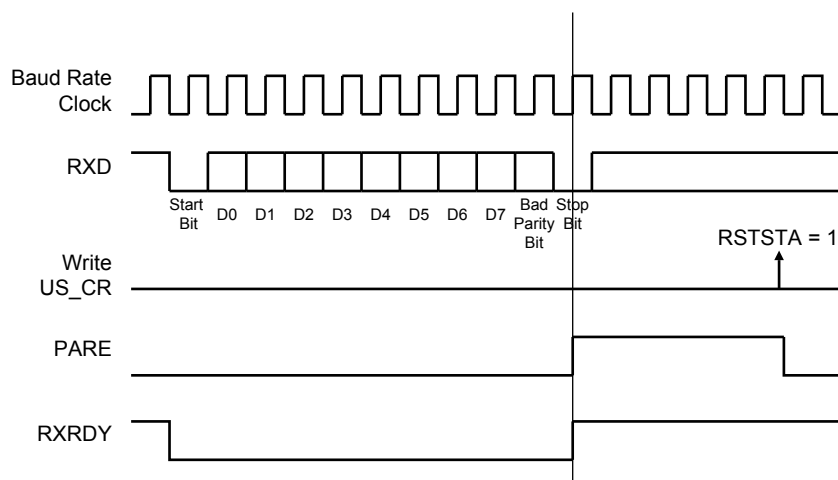

#### 26.7.4.3 Multidrop Mode

If the PAR field in the Mode Register (MR) is programmed to the value 0x6 or 0x07, the USART runs in Multidrop Mode. This mode differentiates the data characters and the address characters. Data is transmitted with the parity bit at 0 and addresses are transmitted with the parity bit at 1.

If the USART is configured in multidrop mode, the receiver sets the PARE parity error bit when the parity bit is high and the transmitter is able to send a character with the parity bit high when the Control Register is written with the SENDA bit at 1.

To handle parity error, the PARE bit is cleared when the Control Register is written with the bit RSTSTA at 1.

The transmitter sends an address byte (parity bit set) when SENDA is written to CR. In this case, the next byte written to THR is transmitted as an address. Any character written in THR without having written the command SENDA is transmitted normally with the parity at 0.

#### 26.7.4.4 Transmitter Timeguard

The timeguard feature enables the USART interface with slow remote devices.

The timeguard function enables the transmitter to insert an idle state on the TXD line between two characters. This idle state actually acts as a long stop bit.

The duration of the idle state is programmed in the TG field of the Transmitter Timeguard Register (TTGR). When this field is programmed at zero no timeguard is generated. Otherwise, the transmitter holds a high level on TXD after each transmitted byte during the number of bit periods programmed in TG in addition to the number of stop bits.

As illustrated in [Figure 26-23 on page 322](#), the behavior of TXRDY and TXEMPTY status bits is modified by the programming of a timeguard. TXRDY rises only when the start bit of the next character is sent, and thus remains at 0 during the timeguard transmission if a character has been written in THR. TXEMPTY remains low until the timeguard transmission is completed as the timeguard is part of the current character being transmitted.

**Figure 26-23.** Timeguard Operations

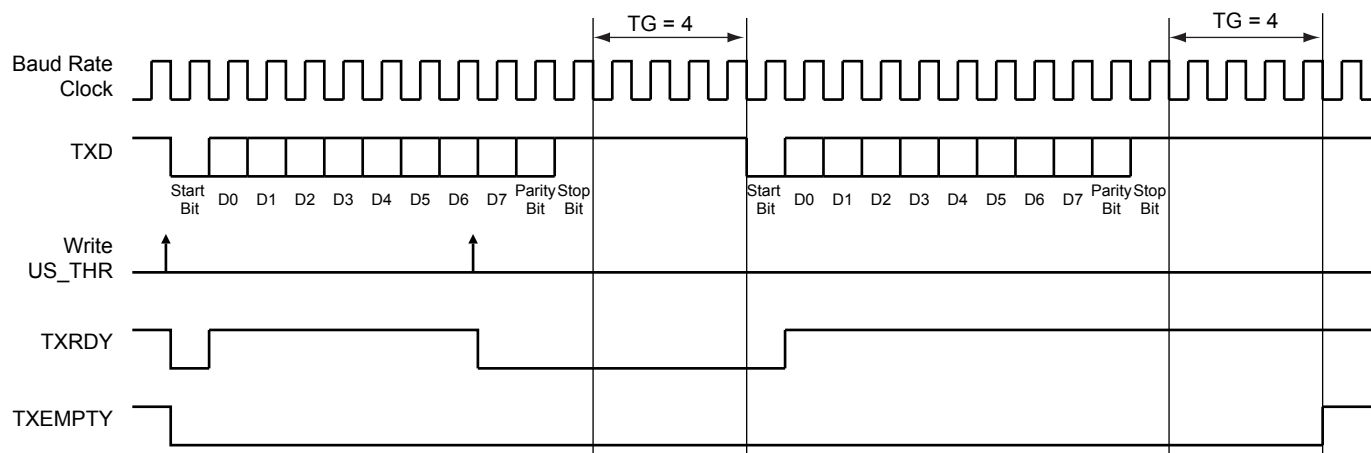

Table 26-7 on page 322 indicates the maximum length of a timeguard period that the transmitter can handle in relation to the function of the Baud Rate.

**Table 26-7.** Maximum Timeguard Length Depending on Baud Rate

Baud Rate	Bit time	Timeguard
Bit/sec	µs	ms
1 200	833	212.50
9 600	104	26.56
14400	69.4	17.71
19200	52.1	13.28
28800	34.7	8.85
33400	29.9	7.63
56000	17.9	4.55
57600	17.4	4.43
115200	8.7	2.21

### 26.7.4.5 Receiver Time-out

The Receiver Time-out provides support in handling variable-length frames. This feature detects an idle condition on the RXD line. When a time-out is detected, the bit TIMEOUT in the Channel Status Register (CSR) rises and can generate an interrupt, thus indicating to the driver an end of frame.

The time-out delay period (during which the receiver waits for a new character) is programmed in the TO field of the Receiver Time-out Register (RTOR). If the TO field is programmed at 0, the Receiver Time-out is disabled and no time-out is detected. The TIMEOUT bit in CSR remains at 0. Otherwise, the receiver loads a 16-bit counter with the value programmed in TO. This counter is decremented at each bit period and reloaded each time a new character is received. If the counter reaches 0, the TIMEOUT bit in the Status Register rises. Then, the user can either:

- Stop the counter clock until a new character is received. This is performed by writing the Control Register (CR) with the STTTO (Start Time-out) bit at 1. In this case, the idle state on RXD before a new character is received will not provide a time-out. This prevents having to

handle an interrupt before a character is received and allows waiting for the next idle state on RXD after a frame is received.

- Obtain an interrupt while no character is received. This is performed by writing CR with the RETTO (Reload and Start Time-out) bit at 1. If RETTO is performed, the counter starts counting down immediately from the value TO. This enables generation of a periodic interrupt so that a user time-out can be handled, for example when no key is pressed on a keyboard.

If STTTO is performed, the counter clock is stopped until a first character is received. The idle state on RXD before the start of the frame does not provide a time-out. This prevents having to obtain a periodic interrupt and enables a wait of the end of frame when the idle state on RXD is detected.

If RETTO is performed, the counter starts counting down immediately from the value TO. This enables generation of a periodic interrupt so that a user time-out can be handled, for example when no key is pressed on a keyboard.

Figure 26-24 on page 323 shows the block diagram of the Receiver Time-out feature.

**Figure 26-24.** Receiver Time-out Block Diagram

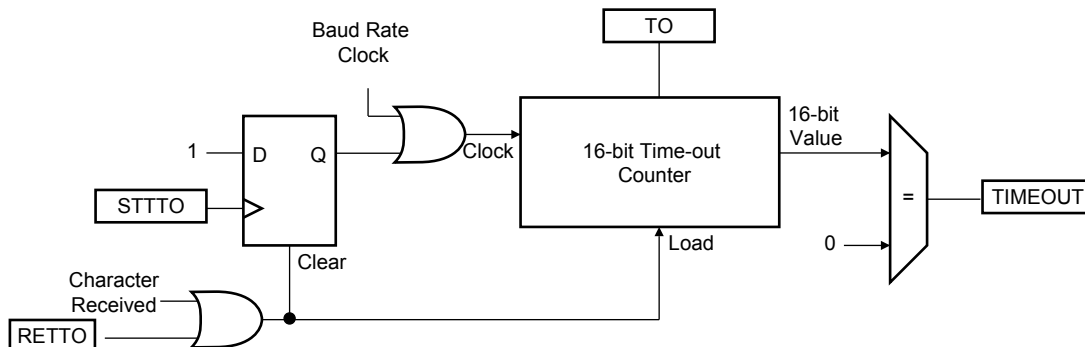

Table 26-8 on page 323 gives the maximum time-out period for some standard baud rates.

**Table 26-8.** Maximum Time-out Period

Baud Rate	Bit Time	Time-out
bit/sec	μs	ms
600	1 667	109 225
1 200	833	54 613
2 400	417	27 306
4 800	208	13 653
9 600	104	6 827
14400	69	4 551
19200	52	3 413
28800	35	2 276
33400	30	1 962
56000	18	1 170
57600	17	1 138
200000	5	328

## 26.7.4.6 Framing Error

The receiver is capable of detecting framing errors. A framing error happens when the stop bit of a received character is detected at level 0. This can occur if the receiver and the transmitter are fully desynchronized.

A framing error is reported on the FRAME bit of the Channel Status Register (CSR). The FRAME bit is asserted in the middle of the stop bit as soon as the framing error is detected. It is cleared by writing the Control Register (CR) with the RSTSTA bit at 1.

**Figure 26-25.** Framing Error Status

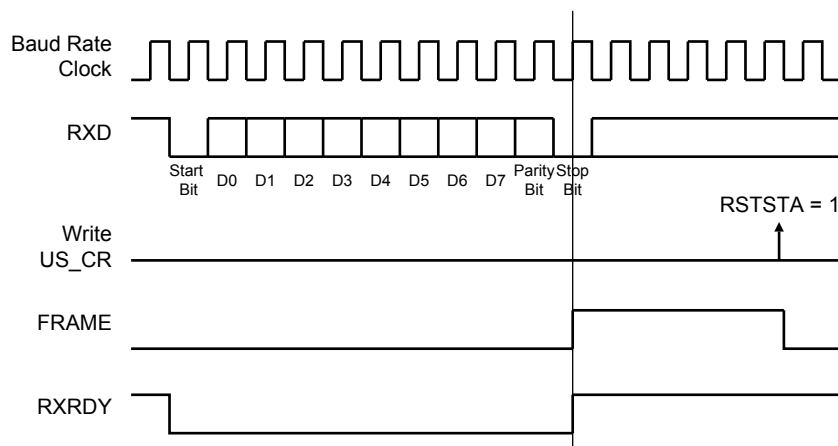

## 26.7.4.7 Transmit Break

The user can request the transmitter to generate a break condition on the TXD line. A break condition drives the TXD line low during at least one complete character. It appears the same as a 0x00 character sent with the parity and the stop bits at 0. However, the transmitter holds the TXD line at least during one character until the user requests the break condition to be removed.

A break is transmitted by writing the Control Register (CR) with the STTBRK bit at 1. This can be performed at any time, either while the transmitter is empty (no character in either the Shift Register or in THR) or when a character is being transmitted. If a break is requested while a character is being shifted out, the character is first completed before the TXD line is held low.

Once STTBRK command is requested further STTBRK commands are ignored until the end of the break is completed.

The break condition is removed by writing CR with the STPBRK bit at 1. If the STPBRK is requested before the end of the minimum break duration (one character, including start, data, parity and stop bits), the transmitter ensures that the break condition completes.

The transmitter considers the break as though it is a character, i.e. the STTBRK and STPBRK commands are taken into account only if the TXRDY bit in CSR is at 1 and the start of the break condition clears the TXRDY and TXEMPTY bits as if a character is processed.

Writing CR with the both STTBRK and STPBRK bits at 1 can lead to an unpredictable result. All STPBRK commands requested without a previous STTBRK command are ignored. A byte written into the Transmit Holding Register while a break is pending, but not started, is ignored.

After the break condition, the transmitter returns the TXD line to 1 for a minimum of 12 bit times. Thus, the transmitter ensures that the remote receiver detects correctly the end of break and the start of the next character. If the timeguard is programmed with a value higher than 12, the TXD line is held high for the timeguard period.

After holding the TXD line for this period, the transmitter resumes normal operations.

Figure 26-26 on page 325 illustrates the effect of both the Start Break (STTBK) and Stop Break (STPBK) commands on the TXD line.

**Figure 26-26.** Break Transmission

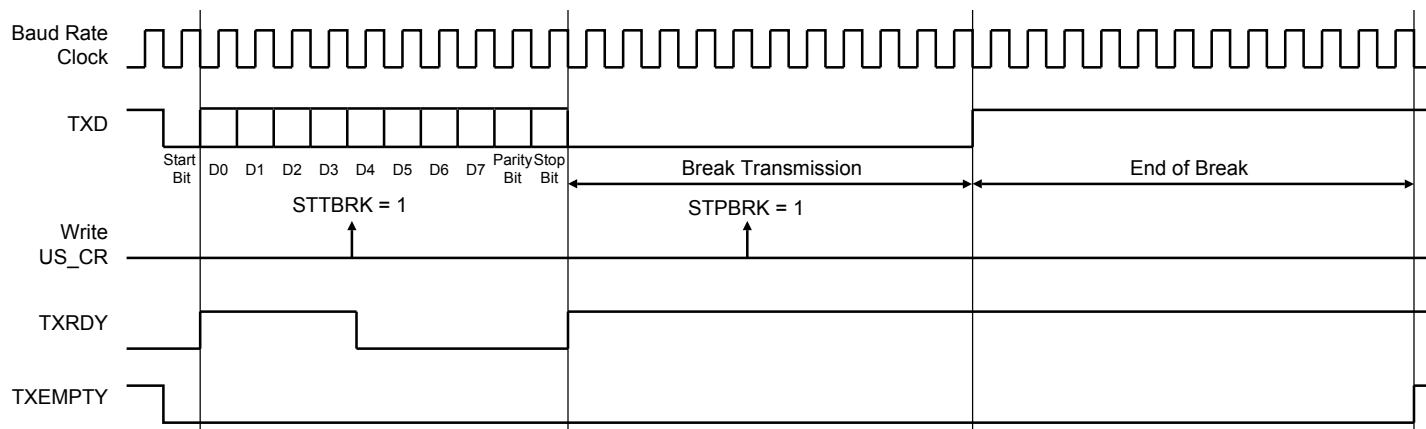

### 26.7.4.8 Receive Break

The receiver detects a break condition when all data, parity and stop bits are low. This corresponds to detecting a framing error with data at 0x00, but FRAME remains low.

When the low stop bit is detected, the receiver asserts the RXBRK bit in CSR. This bit may be cleared by writing the Control Register (CR) with the bit RSTSTA at 1.

An end of receive break is detected by a high level for at least 2/16 of a bit period in asynchronous operating mode or one sample at high level in synchronous operating mode. The end of break detection also asserts the RXBRK bit.

### 26.7.4.9 Hardware Handshaking

The USART features a hardware handshaking out-of-band flow control. The RTS and CTS pins are used to connect with the remote device, as shown in Figure 26-27 on page 325.

**Figure 26-27.** Connection with a Remote Device for Hardware Handshaking

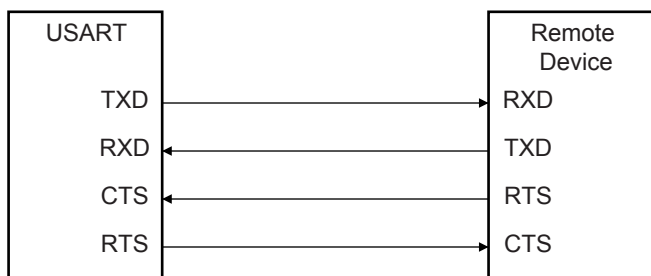

Setting the USART to operate with hardware handshaking is performed by writing the MODE field in the Mode Register (MR) to the value 0x2.

The USART behavior when hardware handshaking is enabled is the same as the behavior in standard synchronous or asynchronous mode, except that the receiver drives the RTS pin as described below and the level on the CTS pin modifies the behavior of the transmitter as described below. Using this mode requires using the PDC channel for reception. The transmitter can handle hardware handshaking in any case.

Figure 26-28 on page 326 shows how the receiver operates if hardware handshaking is enabled. The RTS pin is driven high if the receiver is disabled and if the status RXBUFF (Receive Buffer Full) coming from the PDC channel is high. Normally, the remote device does not start transmitting while its CTS pin (driven by RTS) is high. As soon as the Receiver is enabled, the RTS falls, indicating to the remote device that it can start transmitting. Defining a new buffer to the PDC clears the status bit RXBUFF and, as a result, asserts the pin RTS low.

**Figure 26-28.** Receiver Behavior when Operating with Hardware Handshaking

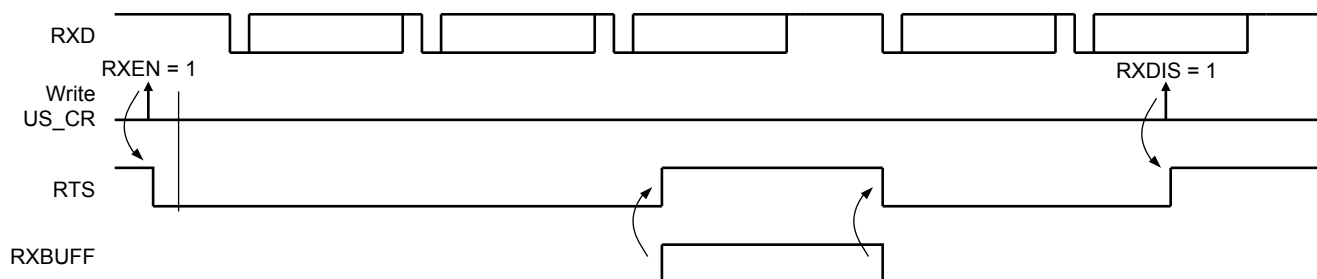

Figure 26-29 on page 326 shows how the transmitter operates if hardware handshaking is enabled. The CTS pin disables the transmitter. If a character is being processing, the transmitter is disabled only after the completion of the current character and transmission of the next character happens as soon as the pin CTS falls.

**Figure 26-29.** Transmitter Behavior when Operating with Hardware Handshaking



## 26.7.5 ISO7816 Mode

The USART features an ISO7816-compatible operating mode. This mode permits interfacing with smart cards and Security Access Modules (SAM) communicating through an ISO7816 link. Both T = 0 and T = 1 protocols defined by the ISO7816 specification are supported.

Setting the USART in ISO7816 mode is performed by writing the MODE field in the Mode Register (MR) to the value 0x4 for protocol T = 0 and to the value 0x5 for protocol T = 1.

### 26.7.5.1 ISO7816 Mode Overview

The ISO7816 is a half duplex communication on only one bidirectional line. The baud rate is determined by a division of the clock provided to the remote device (see "Baud Rate Generator" on page 305).

The USART connects to a smart card as shown in Figure 26-30 on page 327. The TXD line becomes bidirectional and the Baud Rate Generator feeds the ISO7816 clock on the CLK pin.

As the TXD pin becomes bidirectional, its output remains driven by the output of the transmitter but only when the transmitter is active while its input is directed to the input of the receiver. The USART is considered as the master of the communication as it generates the clock.

**Figure 26-30.** Connection of a Smart Card to the USART

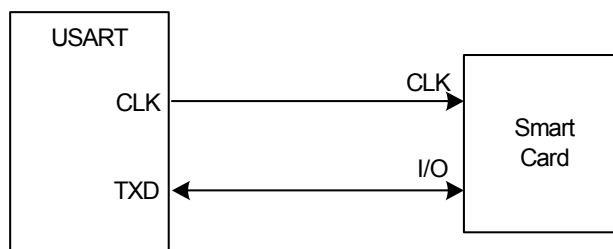

When operating in ISO7816, either in T = 0 or T = 1 modes, the character format is fixed. The configuration is 8 data bits, even parity and 1 or 2 stop bits, regardless of the values programmed in the CHRL, MODE9, PAR and CHMODE fields. MSBF can be used to transmit LSB or MSB first. Parity Bit (PAR) can be used to transmit in normal or inverse mode. Refer to ["USART Mode Register" on page 343](#) and ["PAR: Parity Type" on page 345](#).

The USART cannot operate concurrently in both receiver and transmitter modes as the communication is unidirectional at a time. It has to be configured according to the required mode by enabling or disabling either the receiver or the transmitter as desired. Enabling both the receiver and the transmitter at the same time in ISO7816 mode may lead to unpredictable results.

The ISO7816 specification defines an inverse transmission format. Data bits of the character must be transmitted on the I/O line at their negative value. The USART does not support this format and the user has to perform an exclusive OR on the data before writing it in the Transmit Holding Register (THR) or after reading it in the Receive Holding Register (RHR).

#### 26.7.5.2 Protocol T = 0

In T = 0 protocol, a character is made up of one start bit, eight data bits, one parity bit and one guard time, which lasts two bit times. The transmitter shifts out the bits and does not drive the I/O line during the guard time.

If no parity error is detected, the I/O line remains at 1 during the guard time and the transmitter can continue with the transmission of the next character, as shown in [Figure 26-31 on page 328](#).

If a parity error is detected by the receiver, it drives the I/O line at 0 during the guard time, as shown in [Figure 26-32 on page 328](#). This error bit is also named NACK, for Non Acknowledge. In this case, the character lasts 1 bit time more, as the guard time length is the same and is added to the error bit time which lasts 1 bit time.

When the USART is the receiver and it detects an error, it does not load the erroneous character in the Receive Holding Register (RHR). It appropriately sets the PARE bit in the Status Register (SR) so that the software can handle the error.

**Figure 26-31.** T = 0 Protocol without Parity Error

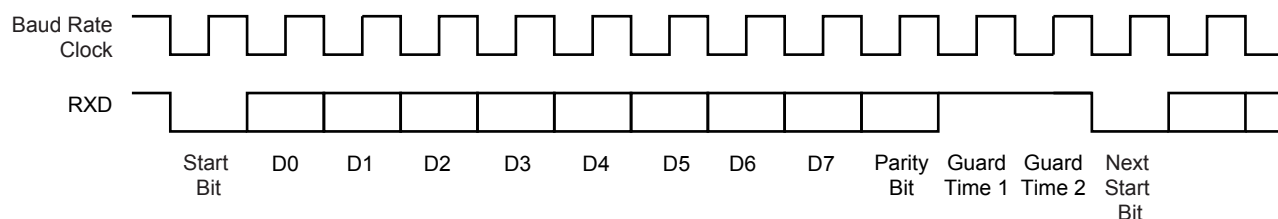

**Figure 26-32.** T = 0 Protocol with Parity Error

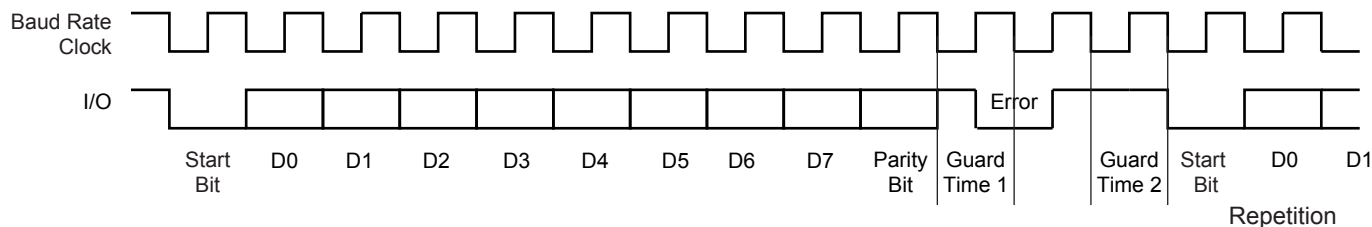

### 26.7.5.3 Receive Error Counter

The USART receiver also records the total number of errors. This can be read in the Number of Error (NER) register. The NB\_ERRORS field can record up to 255 errors. Reading NER automatically clears the NB\_ERRORS field.

### 26.7.5.4 Receive NACK Inhibit

The USART can also be configured to inhibit an error. This can be achieved by setting the INACK bit in the Mode Register (MR). If INACK is at 1, no error signal is driven on the I/O line even if a parity bit is detected, but the INACK bit is set in the Status Register (SR). The INACK bit can be cleared by writing the Control Register (CR) with the RSTNACK bit at 1.

Moreover, if INACK is set, the erroneous received character is stored in the Receive Holding Register, as if no error occurred. However, the RXRDY bit does not raise.

### 26.7.5.5 Transmit Character Repetition

When the USART is transmitting a character and gets a NACK, it can automatically repeat the character before moving on to the next one. Repetition is enabled by writing the MAX\_ITERATION field in the Mode Register (MR) at a value higher than 0. Each character can be transmitted up to eight times; the first transmission plus seven repetitions.

If MAX\_ITERATION does not equal zero, the USART repeats the character as many times as the value loaded in MAX\_ITERATION.

When the USART repetition number reaches MAX\_ITERATION, the ITERATION bit is set in the Channel Status Register (CSR). If the repetition of the character is acknowledged by the receiver, the repetitions are stopped and the iteration counter is cleared.

The ITERATION bit in CSR can be cleared by writing the Control Register with the RSIT bit at 1.

### 26.7.5.6 Disable Successive Receive NACK

The receiver can limit the number of successive NACKs sent back to the remote transmitter. This is programmed by setting the bit DSNACK in the Mode Register (MR). The maximum number of NACK transmitted is programmed in the MAX\_ITERATION field. As soon as



MAX\_ITERATION is reached, the character is considered as correct, an acknowledge is sent on the line and the ITERATION bit in the Channel Status Register is set.

## 26.7.5.7 Protocol T = 1

When operating in ISO7816 protocol T = 1, the transmission is similar to an asynchronous format with only one stop bit. The parity is generated when transmitting and checked when receiving. Parity error detection sets the PARE bit in the Channel Status Register (CSR).

## 26.7.6 IrDA Mode

The USART features an IrDA mode supplying half-duplex point-to-point wireless communication. It embeds the modulator and demodulator which allows a glueless connection to the infrared transceivers, as shown in [Figure 26-33 on page 329](#). The modulator and demodulator are compliant with the IrDA specification version 1.1 and support data transfer speeds ranging from 2.4 Kb/s to 115.2 Kb/s.

The USART IrDA mode is enabled by setting the MODE field in the Mode Register (MR) to the value 0x8. The IrDA Filter Register (IFR) allows configuring the demodulator filter. The USART transmitter and receiver operate in a normal asynchronous mode and all parameters are accessible. Note that the modulator and the demodulator are activated.

**Figure 26-33.** Connection to IrDA Transceivers

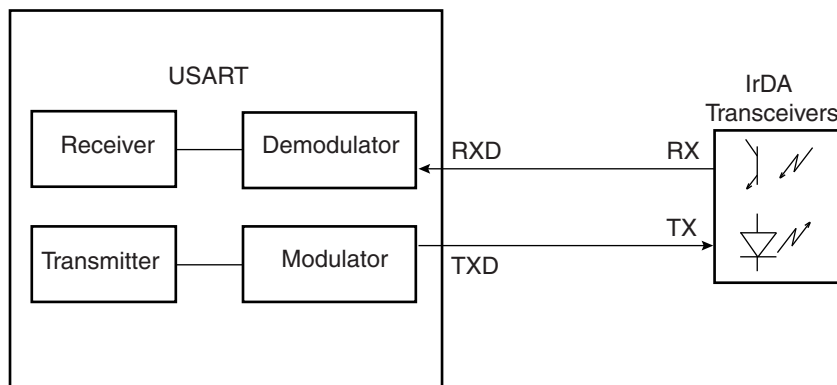

The receiver and the transmitter must be enabled or disabled according to the direction of the transmission to be managed.

### 26.7.6.1 IrDA Modulation

For baud rates up to and including 115.2 Kbits/sec, the RZ1 modulation scheme is used. “0” is represented by a light pulse of 3/16th of a bit time. Some examples of signal pulse duration are shown in [Table 26-9 on page 329](#).

**Table 26-9.** IrDA Pulse Duration

Baud Rate	Pulse Duration (3/16)
2.4 Kb/s	78.13 $\mu$ s
9.6 Kb/s	19.53 $\mu$ s
19.2 Kb/s	9.77 $\mu$ s

**Table 26-9.** IrDA Pulse Duration

Baud Rate	Pulse Duration (3/16)
38.4 Kb/s	4.88 μs
57.6 Kb/s	3.26 μs
115.2 Kb/s	1.63 μs

Figure 26-34 on page 330 shows an example of character transmission.

**Figure 26-34.** IrDA Modulation

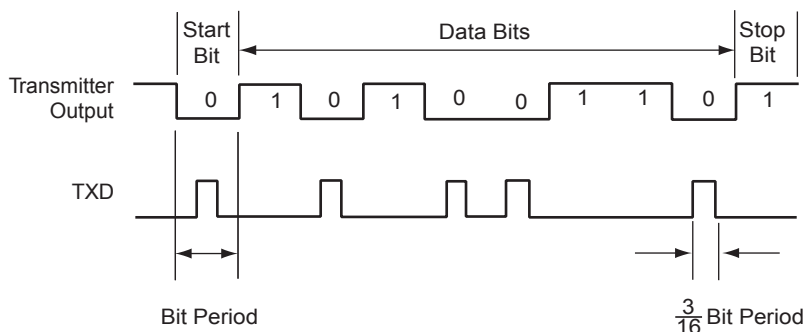

## 26.7.6.2 IrDA Baud Rate

Table 26-10 on page 330 gives some examples of CD values, baud rate error and pulse duration. Note that the requirement on the maximum acceptable error of  $\pm 1.87\%$  must be met.

**Table 26-10.** IrDA Baud Rate Error

Peripheral Clock	Baud Rate	CD	Baud Rate Error	Pulse Time
3 686 400	115 200	2	0.00%	1.63
20 000 000	115 200	11	1.38%	1.63
32 768 000	115 200	18	1.25%	1.63
40 000 000	115 200	22	1.38%	1.63
3 686 400	57 600	4	0.00%	3.26
20 000 000	57 600	22	1.38%	3.26
32 768 000	57 600	36	1.25%	3.26
40 000 000	57 600	43	0.93%	3.26
3 686 400	38 400	6	0.00%	4.88
20 000 000	38 400	33	1.38%	4.88
32 768 000	38 400	53	0.63%	4.88
40 000 000	38 400	65	0.16%	4.88
3 686 400	19 200	12	0.00%	9.77
20 000 000	19 200	65	0.16%	9.77
32 768 000	19 200	107	0.31%	9.77
40 000 000	19 200	130	0.16%	9.77

**Table 26-10.** IrDA Baud Rate Error (Continued)

Peripheral Clock	Baud Rate	CD	Baud Rate Error	Pulse Time
3 686 400	9 600	24	0.00%	19.53
20 000 000	9 600	130	0.16%	19.53
32 768 000	9 600	213	0.16%	19.53
40 000 000	9 600	260	0.16%	19.53
3 686 400	2 400	96	0.00%	78.13
20 000 000	2 400	521	0.03%	78.13
32 768 000	2 400	853	0.04%	78.13

### 26.7.6.3 IrDA Demodulator

The demodulator is based on the IrDA Receive filter comprised of an 8-bit down counter which is loaded with the value programmed in IFR. When a falling edge is detected on the RXD pin, the Filter Counter starts counting down at the CLK\_USART speed. If a rising edge is detected on the RXD pin, the counter stops and is reloaded with IFR. If no rising edge is detected when the counter reaches 0, the input of the receiver is driven low during one bit time.

Figure 26-35 on page 331 illustrates the operations of the IrDA demodulator.

**Figure 26-35.** IrDA Demodulator Operations

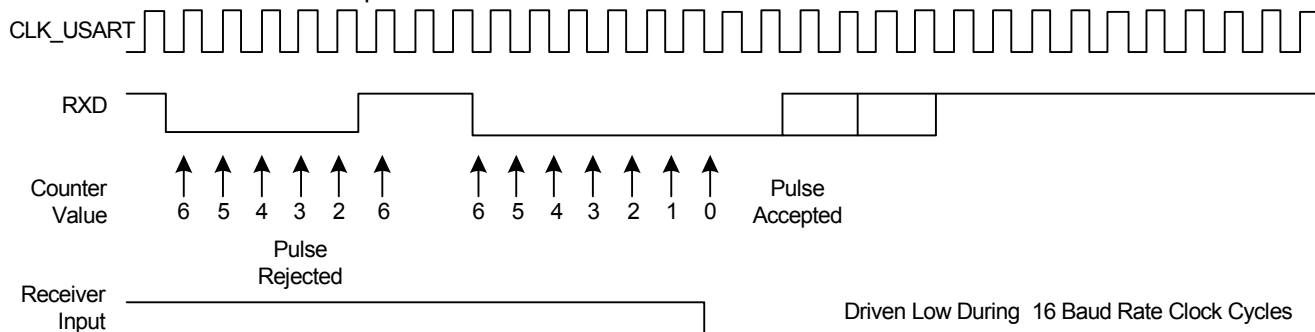

As the IrDA mode uses the same logic as the ISO7816, note that the FI\_DI\_RATIO field in FIDI must be set to a value higher than 0 in order to assure IrDA communications operate correctly.

## 26.7.7 RS485 Mode

The USART features the RS485 mode to enable line driver control. While operating in RS485 mode, the USART behaves as though in asynchronous or synchronous mode and configuration of all the parameters is possible. The difference is that the RTS pin is driven high when the transmitter is operating. The behavior of the RTS pin is controlled by the TXEMPTY bit. A typical connection of the USART to a RS485 bus is shown in [Figure 26-36 on page 332](#).

**Figure 26-36.** Typical Connection to a RS485 Bus

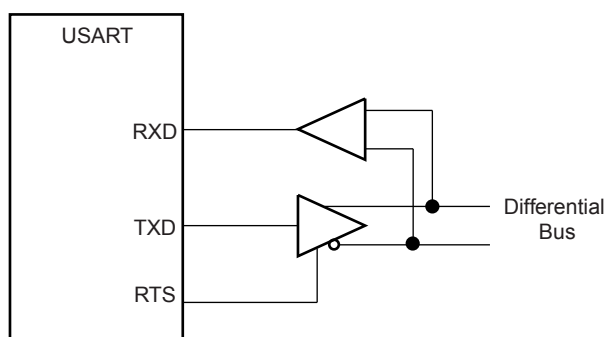

The USART is set in RS485 mode by programming the MODE field in the Mode Register (MR) to the value 0x1.

The RTS pin is at a level inverse to the TXEMPTY bit. Significantly, the RTS pin remains high when a timeguard is programmed so that the line can remain driven after the last character completion. [Figure 26-37 on page 332](#) gives an example of the RTS waveform during a character transmission when the timeguard is enabled.

**Figure 26-37.** Example of RTS Drive with Timeguard

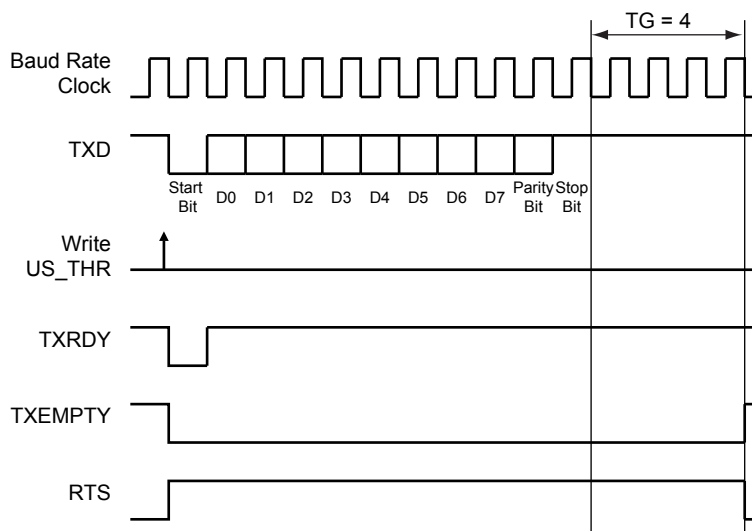

## 26.7.8 SPI Mode

The Serial Peripheral Interface (SPI) Mode is a synchronous serial data link that provides communication with external devices in Master or Slave Mode. It also enables communication between processors if an external processor is connected to the system.

The Serial Peripheral Interface is essentially a shift register that serially transmits data bits to other SPIs. During a data transfer, one SPI system acts as the “master” which controls the data flow, while the other devices act as “slaves” which have data shifted into and out by the master. Different CPUs can take turns being masters and one master may simultaneously shift data into multiple slaves. (Multiple Master Protocol is the opposite of Single Master Protocol, where one CPU is always the master while all of the others are always slaves.) However, only one slave may drive its output to write data back to the master at any given time.

A slave device is selected when its NSS signal is asserted by the master. The USART in SPI Master mode can address only one SPI Slave because it can generate only one NSS signal.

The SPI system consists of two data lines and two control lines:

- Master Out Slave In (MOSI): This data line supplies the output data from the master shifted into the input of the slave.
- Master In Slave Out (MISO): This data line supplies the output data from a slave to the input of the master.
- Serial Clock (CLK): This control line is driven by the master and regulates the flow of the data bits. The master may transmit data at a variety of baud rates. The CLK line cycles once for each bit that is transmitted.
- Slave Select (NSS): This control line allows the master to select or deselect the slave.

### 26.7.8.1 Modes of Operation

The USART can operate in Master Mode or in Slave Mode.

Operation in SPI Master Mode is programmed by writing at 0xE the MODE field in the Mode Register. In this case the SPI lines must be connected as described below:

- the MOSI line is driven by the output pin TXD
- the MISO line drives the input pin RXD
- the CLK line is driven by the output pin CLK
- the NSS line is driven by the output pin RTS

Operation in SPI Slave Mode is programmed by writing at 0xF the MODE field in the Mode Register. In this case the SPI lines must be connected as described below:

- the MOSI line drives the input pin RXD
- the MISO line is driven by the output pin TXD
- the CLK line drives the input pin CLK
- the NSS line drives the input pin CTS

In order to avoid unpredicted behavior, any change of the SPI Mode must be followed by a software reset of the transmitter and of the receiver (except the initial configuration after a hardware reset).

## 26.7.8.2 Baud Rate

In SPI Mode, the baudrate generator operates in the same way as in USART synchronous mode: [See Section “26.7.1.4” on page 307](#). However, there are some restrictions:

In SPI Master Mode:

- the external clock CLK must not be selected (USCLKS ... 0x3), and the bit CLKO must be set to “1” in the Mode Register (MR), in order to generate correctly the serial clock on the CLK pin.
- to obtain correct behavior of the receiver and the transmitter, the value programmed in CD of must be superior or equal to 4.
- if the internal clock divided (CLK\_USART/DIV) is selected, the value programmed in CD must be even to ensure a 50:50 mark/space ratio on the CLK pin, this value can be odd if the internal clock is selected (CLK\_USART).

In SPI Slave Mode:

- the external clock (CLK) selection is forced regardless of the value of the USCLKS field in the Mode Register (MR). Likewise, the value written in BRGR has no effect, because the clock is provided directly by the signal on the USART CLK pin.
- to obtain correct behavior of the receiver and the transmitter, the external clock (CLK) frequency must be at least 4 times lower than the system clock.

## 26.7.8.3 Data Transfer

Up to 9 data bits are successively shifted out on the TXD pin at each rising or falling edge (depending of CPOL and CPHA) of the programmed serial clock. There is no Start bit, no Parity bit and no Stop bit.

The number of data bits is selected by the CHRL field and the MODE 9 bit in the Mode Register (MR). The 9 bits are selected by setting the MODE 9 bit regardless of the CHRL field. The MSB data bit is always sent first in SPI Mode (Master or Slave).

Four combinations of polarity and phase are available for data transfers. The clock polarity is programmed with the CPOL bit in the Mode Register. The clock phase is programmed with the CPHA bit. These two parameters determine the edges of the clock signal upon which data is driven and sampled. Each of the two parameters has two possible states, resulting in four possible combinations that are incompatible with one another. Thus, a master/slave pair must use the same parameter pair values to communicate. If multiple slaves are used and fixed in different configurations, the master must reconfigure itself each time it needs to communicate with a different slave.

**Table 26-11.** SPI Bus Protocol Mode

SPI Bus Protocol Mode	CPOL	CPHA
0	0	1
1	0	0
2	1	1
3	1	0

**Figure 26-38.** SPI Transfer Format (CPHA=1, 8 bits per transfer)

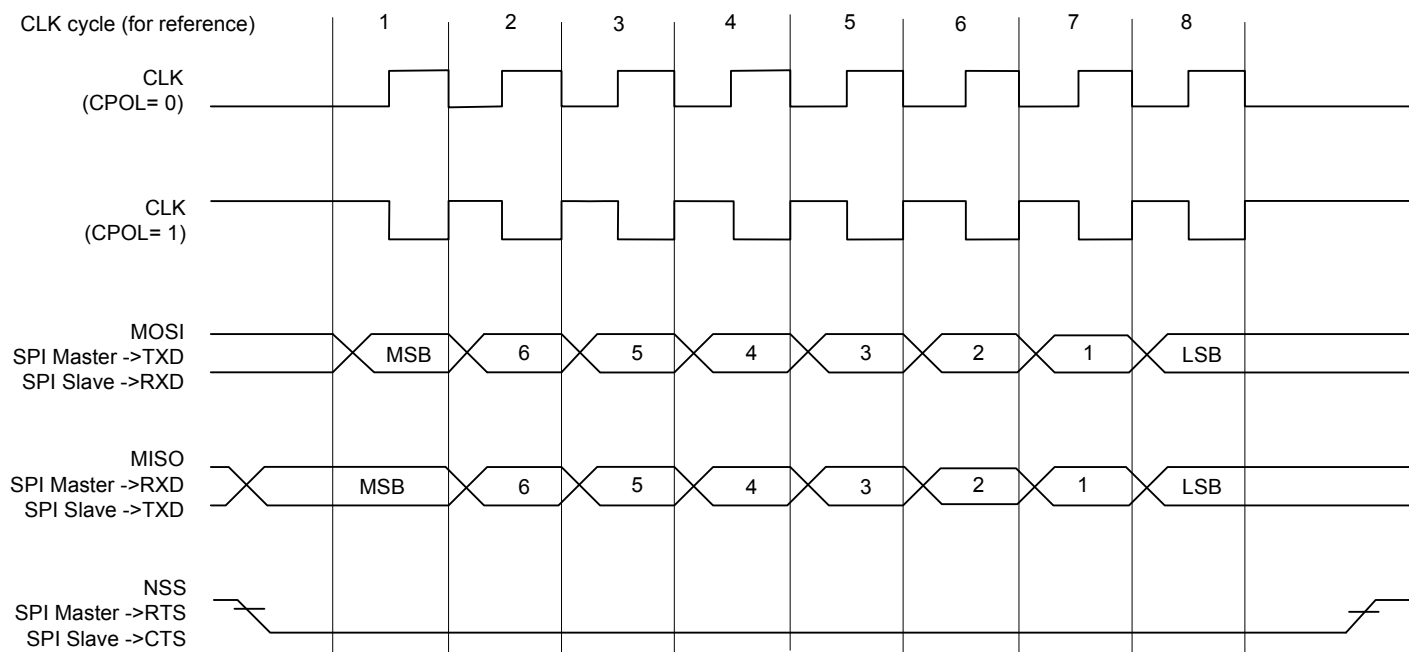

**Figure 26-39.** SPI Transfer Format (CPHA=0, 8 bits per transfer)

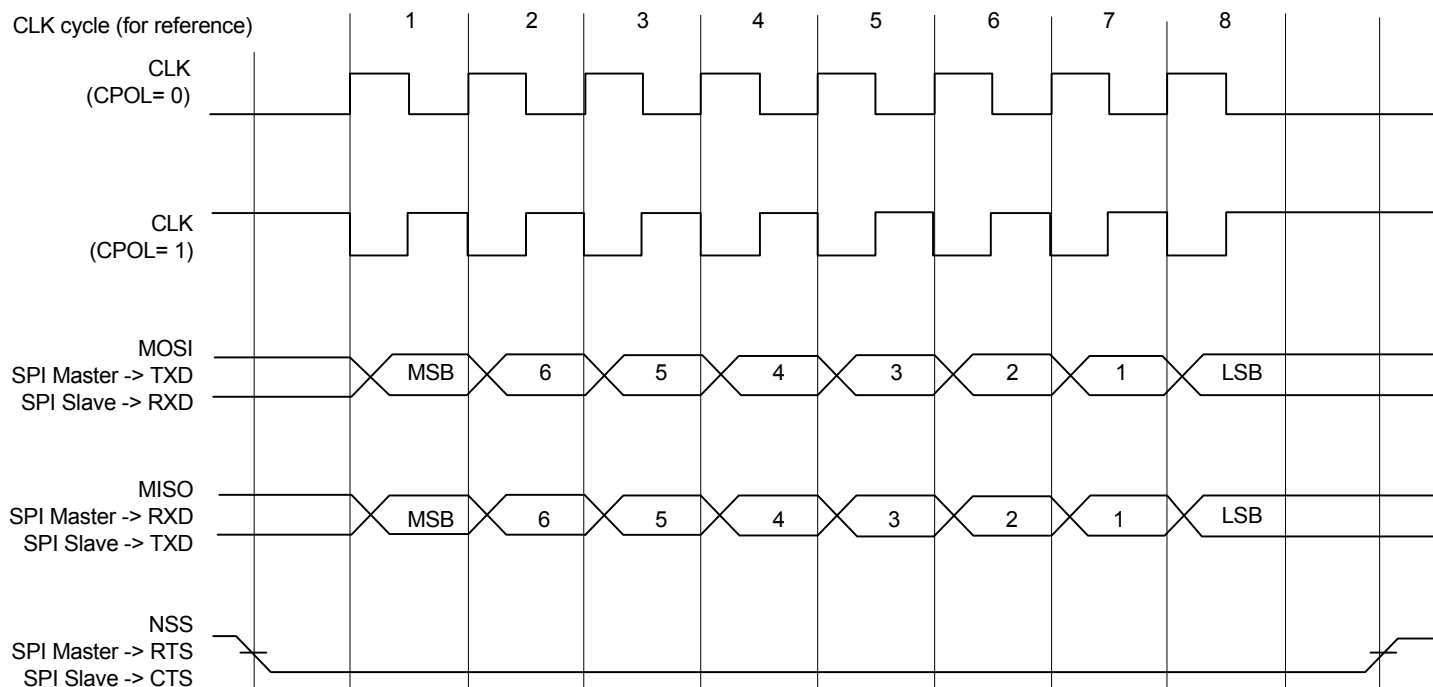

### 26.7.8.4 Receiver and Transmitter Control

See Section “26.7.2” on page 309.

### 26.7.8.5 Character Transmission

The characters are sent by writing in the Transmit Holding Register (THR). The transmitter reports two status bits in the Channel Status Register (CSR): TXRDY (Transmitter Ready), which indicates that THR is empty and TXEMPTY, which indicates that all the characters written in THR have been processed. When the current character processing is completed, the last character written in THR is transferred into the Shift Register of the transmitter and THR becomes empty, thus TXRDY rises.

Both TXRDY and TXEMPTY bits are low when the transmitter is disabled. Writing a character in THR while TXRDY is low has no effect and the written character is lost.

If the USART is in SPI Slave Mode and if a character must be sent while the Transmit Holding Register (THR) is empty, the UNRE (Underrun Error) bit is set. The TXD transmission line stays at high level during all this time. The UNRE bit is cleared by writing the Control Register (CR) with the RSTSTA (Reset Status) bit at 1.

In SPI Master Mode, the slave select line (NSS) is asserted at low level 1 Tbit before the transmission of the MSB bit and released at high level 1 Tbit after the transmission of the LSB bit. So, the slave select line (NSS) is always released between each character transmission and a minimum delay of 3 Tbits always inserted. However, in order to address slave devices supporting the CSAAT mode (Chip Select Active After Transfer), the slave select line (NSS) can be forced at low level by writing the Control Register (CR) with the RTSEN bit at 1. The slave select line (NSS) can be released at high level only by writing the Control Register (CR) with the RTSDIS bit at 1 (for example, when all data have been transferred to the slave device).

In SPI Slave Mode, the transmitter does not require a falling edge of the slave select line (NSS) to initiate a character transmission but only a low level. However, this low level must be present on the slave select line (NSS) at least 1 Tbit before the first serial clock cycle corresponding to the MSB bit.

### 26.7.8.6 Character Reception

When a character reception is completed, it is transferred to the Receive Holding Register (RHR) and the RXRDY bit in the Status Register (CSR) rises. If a character is completed while RXRDY is set, the OVRE (Overrun Error) bit is set. The last character is transferred into RHR and overwrites the previous one. The OVRE bit is cleared by writing the Control Register (CR) with the RSTSTA (Reset Status) bit at 1.

To ensure correct behavior of the receiver in SPI Slave Mode, the master device sending the frame must ensure a minimum delay of 1 Tbit between each character transmission. The receiver does not require a falling edge of the slave select line (NSS) to initiate a character reception but only a low level. However, this low level must be present on the slave select line (NSS) at least 1 Tbit before the first serial clock cycle corresponding to the MSB bit.

### 26.7.8.7 Receiver Timeout

Because the receiver baudrate clock is active only during data transfers in SPI Mode, a receiver timeout is impossible in this mode, whatever the Time-out value is (field TO) in the Time-out Register (RTOR).



## 26.7.9 Test Modes

The USART can be programmed to operate in three different test modes. The internal loopback capability allows on-board diagnostics. In the loopback mode the USART interface pins are disconnected or not and reconfigured for loopback internally or externally.

### 26.7.9.1 Normal Mode

Normal mode connects the RXD pin on the receiver input and the transmitter output on the TXD pin.

**Figure 26-40.** Normal Mode Configuration

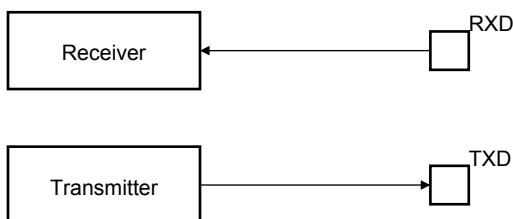

### 26.7.9.2 Automatic Echo Mode

Automatic echo mode allows bit-by-bit retransmission. When a bit is received on the RXD pin, it is sent to the TXD pin, as shown in [Figure 26-41 on page 337](#). Programming the transmitter has no effect on the TXD pin. The RXD pin is still connected to the receiver input, thus the receiver remains active.

**Figure 26-41.** Automatic Echo Mode Configuration

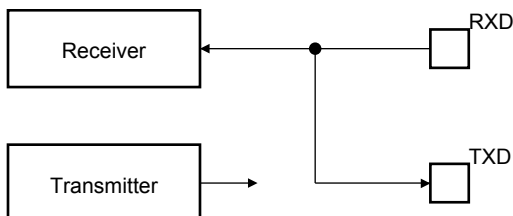

### 26.7.9.3 Local Loopback Mode

Local loopback mode connects the output of the transmitter directly to the input of the receiver, as shown in [Figure 26-42 on page 337](#). The TXD and RXD pins are not used. The RXD pin has no effect on the receiver and the TXD pin is continuously driven high, as in idle state.

**Figure 26-42.** Local Loopback Mode Configuration

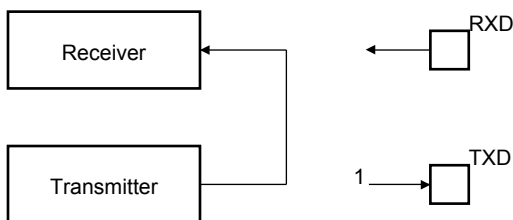

## 26.7.9.4 Remote Loopback Mode

Remote loopback mode directly connects the RXD pin to the TXD pin, as shown in [Figure 26-43 on page 338](#). The transmitter and the receiver are disabled and have no effect. This mode allows bit-by-bit retransmission.

**Figure 26-43.** Remote Loopback Mode Configuration

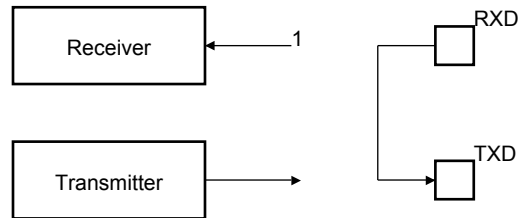

## 26.8 Universal Synchronous/Asynchronous Receiver/Transmitter (USART) User Interface

### 26.8.1 Register Mapping

**Table 26-12.** Register Mapping

Offset	Register	Name	Access	Reset
0x0000	Control Register	CR	Write-only	–
0x0004	Mode Register	MR	Read-write	–
0x0008	Interrupt Enable Register	IER	Write-only	–
0x000C	Interrupt Disable Register	IDR	Write-only	–
0x0010	Interrupt Mask Register	IMR	Read-only	0x0
0x0014	Channel Status Register	CSR	Read-only	–
0x0018	Receiver Holding Register	RHR	Read-only	0x0
0x001C	Transmitter Holding Register	THR	Write-only	–
0x0020	Baud Rate Generator Register	BRGR	Read-write	0x0
0x0024	Receiver Time-out Register	RTOR	Read-write	0x0
0x0028	Transmitter Timeguard Register	TTGR	Read-write	0x0
0x2C - 0x3C	Reserved	–	–	–
0x0040	FI DI Ratio Register	FIDI	Read-write	0x174
0x0044	Number of Errors Register	NER	Read-only	–
0x0048	Reserved	–	–	–
0x004C	IrDA Filter Register	IFR	Read-write	0x0
0x0050	Manchester Encoder Decoder Register	MAN	Read-write	0x30011004
0x5C - 0xF8	Reserved	–	–	–
0xFC	Version Register	VERSION	Read-only	0x <sup>(3)</sup>
0x5C - 0xFC	Reserved	–	–	–

3. Values in the Version Register vary with the version of the IP block implementation.

## 26.8.2 USART Control Register

**Name:** CR  
**Access Type:** Write-only  
**Offset:** 0x0  
**Reset Value:** -

31	30	29	28	27	26	25	24
-	-	-	-	-	-	-	-
23	22	21	20	19	18	17	16
-	-	-	-	RTSDIS/RCS	RTSEN/FCS	-	-
15	14	13	12	11	10	9	8
RETTO	RSTNACK	RSTIT	SENDA	STTTO	STPBRK	STTBRK	RSTSTA
7	6	5	4	3	2	1	0
TXDIS	TXEN	RXDIS	RXEN	RSTTX	RSTRX	-	-

- **RTSDIS/RCS: Request to Send Disable/Release SPI Chip Select**

- If USART does not operate in SPI Master Mode (MODE ... 0xE):

0: No effect.

1: Drives the pin RTS to 1.

- If USART operates in SPI Master Mode (MODE = 0xE):

RCS = 0: No effect.

RCS = 1: Releases the Slave Select Line NSS (RTS pin).

- **RTSEN/FCS: Request to Send Enable/Force SPI Chip Select**

- If USART does not operate in SPI Master Mode (MODE ... 0xE):

0: No effect.

1: Drives the pin RTS to 0.

- If USART operates in SPI Master Mode (MODE = 0xE):

FCS = 0: No effect.

FCS = 1: Forces the Slave Select Line NSS (RTS pin) to 0, even if USART is no transmitting, in order to address SPI slave devices supporting the CSAAT Mode (Chip Select Active After Transfer).

- **RETTO: Rearm Time-out**

0: No effect

1: Restart Time-out

- **RSTNACK: Reset Non Acknowledge**

0: No effect

1: Resets NACK in CSR.

- **RSTIT: Reset Iterations**

0: No effect.

1: Resets ITERATION in CSR. No effect if the ISO7816 is not enabled.

- **SENDA: Send Address**

0: No effect.

1: In Multidrop Mode only, the next character written to the THR is sent with the address bit set.

- **STTTO: Start Time-out**

0: No effect.

1: Starts waiting for a character before clocking the time-out counter. Resets the status bit TIMEOUT in CSR.

- **STPBRK: Stop Break**

0: No effect.

1: Stops transmission of the break after a minimum of one character length and transmits a high level during 12-bit periods. No effect if no break is being transmitted.

- **STTBRK: Start Break**

0: No effect.

1: Starts transmission of a break after the characters present in THR and the Transmit Shift Register have been transmitted. No effect if a break is already being transmitted.

- **RSTSTA: Reset Status Bits**

0: No effect.

1: Resets the status bits PARE, FRAME, OVRE, MANERR and RXBRK in CSR.

- **TXDIS: Transmitter Disable**

0: No effect.

1: Disables the transmitter.

- **TXEN: Transmitter Enable**

0: No effect.

1: Enables the transmitter if TXDIS is 0.

- **RXDIS: Receiver Disable**

0: No effect.

1: Disables the receiver.

- **RXEN: Receiver Enable**

0: No effect.

1: Enables the receiver, if RXDIS is 0.

- **RSTTX: Reset Transmitter**

0: No effect.

1: Resets the transmitter.

- **RSTRX: Reset Receiver**

0: No effect.

1: Resets the receiver.

## 26.8.3 USART Mode Register

**Name:** MR  
**Access Type:** Read-write  
**Offset:** 0x4  
**Reset Value:** -

31	30	29	28	27	26	25	24
ONEBIT	MODSYNC	MAN	FILTER	-	MAX_ITERATION		
23	22	21	20	19	18	17	16
-	VAR_SYNC	DSNACK	INACK	OVER	CLKO	MODE9	MSBF/CPOL
15	14	13	12	11	10	9	8
CHMODE		NBSTOP		PAR			SYNC/CPHA
7	6	5	4	3	2	1	0
CHRL		USCLKS		MODE			

- **ONEBIT: Start Frame Delimiter Selector**

0: Start Frame delimiter is COMMAND or DATA SYNC.

1: Start Frame delimiter is One Bit.

- **MODSYNC: Manchester Synchronization Mode**

0: The Manchester Start bit is a 0 to 1 transition

1: The Manchester Start bit is a 1 to 0 transition.

- **MAN: Manchester Encoder/Decoder Enable**

0: Manchester Encoder/Decoder are disabled.

1: Manchester Encoder/Decoder are enabled.

- **FILTER: Infrared Receive Line Filter**

0: The USART does not filter the receive line.

1: The USART filters the receive line using a three-sample filter (1/16-bit clock) (2 over 3 majority).

- **MAX\_ITERATION**

Defines the maximum number of iterations in mode ISO7816, protocol T= 0.

- **VAR\_SYNC: Variable Synchronization of Command/Data Sync Start Frame Delimiter**

0: User defined configuration of command or data sync field depending on SYNC value.

1: The sync field is updated when a character is written into THR register.

- **DSNACK: Disable Successive NACK**

0: NACK is sent on the ISO line as soon as a parity error occurs in the received character (unless INACK is set).

1: Successive parity errors are counted up to the value specified in the MAX\_ITERATION field. These parity errors generate a NACK on the ISO line. As soon as this value is reached, no additional NACK is sent on the ISO line. The flag ITERATION is asserted.

- **INACK: Inhibit Non Acknowledge**

0: The NACK is generated.

1: The NACK is not generated.

- **OVER: Oversampling Mode**

0: 16x Oversampling.

1: 8x Oversampling.

- **CLKO: Clock Output Select**

0: The USART does not drive the CLK pin.

1: The USART drives the CLK pin if USCLKS does not select the external clock CLK.

- **MODE9: 9-bit Character Length**

0: CHRL defines character length.

1: 9-bit character length.

- **MSBF/CPOL: Bit Order or SPI Clock Polarity**

– If USART does not operate in SPI Mode (MODE ... 0xE and 0xF):

MSBF = 0: Least Significant Bit is sent/received first.

MSBF = 1: Most Significant Bit is sent/received first.

– If USART operates in SPI Mode (Slave or Master, MODE = 0xE or 0xF):

CPOL = 0: The inactive state value of SPCK is logic level zero.

CPOL = 1: The inactive state value of SPCK is logic level one.

CPOL is used to determine the inactive state value of the serial clock (SPCK). It is used with CPHA to produce the required clock/data relationship between master and slave devices.

- **CHMODE: Channel Mode**

CHMODE		Mode Description
0	0	Normal Mode
0	1	Automatic Echo. Receiver input is connected to the TXD pin.
1	0	Local Loopback. Transmitter output is connected to the Receiver Input..
1	1	Remote Loopback. RXD pin is internally connected to the TXD pin.

- **NBSTOP: Number of Stop Bits**

NBSTOP		Asynchronous (SYNC = 0)	Synchronous (SYNC = 1)
0	0	1 stop bit	1 stop bit



0	1	1.5 stop bits	Reserved
1	0	2 stop bits	2 stop bits
1	1	Reserved	Reserved

• **PAR: Parity Type**

PAR			Parity Type
0	0	0	Even parity
0	0	1	Odd parity
0	1	0	Parity forced to 0 (Space)
0	1	1	Parity forced to 1 (Mark)
1	0	x	No parity
1	1	x	Multidrop mode

• **SYNC/CPHA: Synchronous Mode Select or SPI Clock Phase**

– If USART does not operate in SPI Mode (MODE is ... 0xE and 0xF):

SYNC = 0: USART operates in Asynchronous Mode.

SYNC = 1: USART operates in Synchronous Mode.

– If USART operates in SPI Mode (MODE = 0xE or 0xF):

CPHA = 0: Data is changed on the leading edge of SPCK and captured on the following edge of SPCK.

CPHA = 1: Data is captured on the leading edge of SPCK and changed on the following edge of SPCK.

CPHA determines which edge of SPCK causes data to change and which edge causes data to be captured. CPHA is used with CPOL to produce the required clock/data relationship between master and slave devices.

• **CHRL: Character Length.**

CHRL		Character Length
0	0	5 bits
0	1	6 bits
1	0	7 bits
1	1	8 bits

• **USCLKS: Clock Selection**

USCLKS		Selected Clock
0	0	CLK_USART
0	1	CLK_USART/DIV (DIV = xx)
1	0	Reserved
1	1	CLK

• **MODE**

MODE				Mode of the USART
0	0	0	0	Normal
0	0	0	1	RS485
0	0	1	0	Hardware Handshaking
0	1	0	0	IS07816 Protocol: T = 0
0	1	1	0	IS07816 Protocol: T = 1
1	0	0	0	IrDA
1	1	1	0	SPI Master
1	1	1	1	SPI Slave
Others				Reserved

## 26.8.4 USART Interrupt Enable Register

**Name:** IER  
**Access Type:** Write-only  
**Offset:** 0x8  
**Reset Value:** -

31	30	29	28	27	26	25	24
-	-	-	-	-			MANEA
23	22	21	20	19	18	17	16
-	-	-	MANE	CTSIC	-	-	-
15	14	13	12	11	10	9	8
		NACK	RXBUFF	TXBUFE	ITER/UNRE	TXEMPTY	TIMEOUT
7	6	5	4	3	2	1	0
PARE	FRAME	OVRE	ENDTX	ENDRX	RXBRK	TXRDY	RXRDY

- **MANEA: Manchester Error Interrupt Enable**
- **MANE: Manchester Error Interrupt Enable**
- **CTSIC: Clear to Send Input Change Interrupt Enable**
- **NACK: Non Acknowledge Interrupt Enable**
- **RXBUFF: Buffer Full Interrupt Enable**
- **TXBUFE: Buffer Empty Interrupt Enable**
- **ITER/UNRE: Iteration or SPI Underrun Error Interrupt Enable**
- **TXEMPTY: TXEMPTY Interrupt Enable**
- **TIMEOUT: Time-out Interrupt Enable**
- **PARE: Parity Error Interrupt Enable**
- **FRAME: Framing Error Interrupt Enable**
- **OVRE: Overrun Error Interrupt Enable**
- **ENDTX: End of Transmit Interrupt Enable**
- **ENDRX: End of Receive Transfer Interrupt Enable**
- **RXBRK: Receiver Break Interrupt Enable**
- **TXRDY: TXRDY Interrupt Enable**
- **RXRDY: RXRDY Interrupt Enable**

### 26.8.5 USART Interrupt Disable Register

**Name:** IDR

**Access Type:** Write-only

**Offset:** 0xC

**Reset Value:** -

31	30	29	28	27	26	25	24
-	-						MANEA
23	22	21	20	19	18	17	16
-	-	-	MANE	CTSIC	-	-	-
15	14	13	12	11	10	9	8
		NACK	RXBUFF	TXBUFE	ITER/UNRE	TXEMPTY	TIMEOUT
7	6	5	4	3	2	1	0
PARE	FRAME	OVRE	ENDTX	ENDRX	RXBRK	TXRDY	RXRDY

- **MANEA: Manchester Error Interrupt Disable**
- **MANE: Manchester Error Interrupt Disable**
- **CTSIC: Clear to Send Input Change Interrupt Disable**
- **NACK: Non Acknowledge Interrupt Disable**
- **RXBUFF: Buffer Full Interrupt Disable**
- **TXBUFE: Buffer Empty Interrupt Disable**
- **ITER/UNRE: Iteration or SPI Underrun Error Interrupt Enable**
- **TXEMPTY: TXEMPTY Interrupt Disable**
- **TIMEOUT: Time-out Interrupt Disable**
- **PARE: Parity Error Interrupt Disable**
- **FRAME: Framing Error Interrupt Disable**
- **OVRE: Overrun Error Interrupt Disable**
- **ENDTX: End of Transmit Interrupt Disable**
- **ENDRX: End of Receive Transfer Interrupt Disable**
- **RXBRK: Receiver Break Interrupt Disable**
- **TXRDY: TXRDY Interrupt Disable**
- **RXRDY: RXRDY Interrupt Disable**



## 26.8.6 USART Interrupt Mask Register

**Name:** IMR  
**Access Type:** Read-only  
**Offset:** 0x10  
**Reset Value:** 0x00000000

31	30	29	28	27	26	25	24
–	–						MANEA
23	22	21	20	19	18	17	16
–	–	–	MANE	CTSIC	–	–	–
15	14	13	12	11	10	9	8
		NACK	RXBUFF	TXBUFE	ITER/UNRE	TXEMPTY	TIMEOUT
7	6	5	4	3	2	1	0
PARE	FRAME	OVRE	ENDTX	ENDRX	RXBRK	TXRDY	RXRDY

- **MANEA: Manchester Error Interrupt Mask**
- **MANE: Manchester Error Interrupt Mask**
- **CTSIC: Clear to Send Input Change Interrupt Mask**
- **NACK: Non Acknowledge Interrupt Mask**
- **RXBUFF: Buffer Full Interrupt Mask**
- **TXBUFE: Buffer Empty Interrupt Mask**
- **ITER/UNRE: Iteration or SPI Underrun Error Interrupt Enable**
- **TXEMPTY: TXEMPTY Interrupt Mask**
- **TIMEOUT: Time-out Interrupt Mask**
- **PARE: Parity Error Interrupt Mask**
- **FRAME: Framing Error Interrupt Mask**
- **OVRE: Overrun Error Interrupt Mask**
- **ENDTX: End of Transmit Interrupt Mask**
- **ENDRX: End of Receive Transfer Interrupt Mask**
- **RXBRK: Receiver Break Interrupt Mask**
- **TXRDY: TXRDY Interrupt Mask**
- **RXRDY: RXRDY Interrupt Mask**

### 26.8.7 USART Channel Status Register

**Name:** CSR

**Access Type:** Read-only

**Offset:** 0x14

**Reset Value:** -

31	30	29	28	27	26	25	24
-	-						MANERR
23	22	21	20	19	18	17	16
CTS	-	-	-	CTSIC	-	-	-
15	14	13	12	11	10	9	8
		NACK	RXBUFF	TXBUFE	ITER/UNRE	TXEMPTY	TIMEOUT
7	6	5	4	3	2	1	0
PARE	FRAME	OVRE	ENDTX	ENDRX	RXBRK	TXRDY	RXRDY

- **MANERR: Manchester Error**

0: No Manchester error has been detected since the last RSTSTA.

1: At least one Manchester error has been detected since the last RSTSTA.

- **CTS: Image of CTS Input**

0: CTS is at 0.

1: CTS is at 1.

- **CTSIC: Clear to Send Input Change Flag**

0: No input change has been detected on the CTS pin since the last read of CSR.

1: At least one input change has been detected on the CTS pin since the last read of CSR.

- **NACK: Non Acknowledge**

0: No Non Acknowledge has not been detected since the last RSTNACK.

1: At least one Non Acknowledge has been detected since the last RSTNACK.

- **RXBUFF: Reception Buffer Full**

0: The signal Buffer Full from the Receive PDC channel is inactive.

1: The signal Buffer Full from the Receive PDC channel is active.

- **TXBUFE: Transmission Buffer Empty**

0: The signal Buffer Empty from the Transmit PDC channel is inactive.

1: The signal Buffer Empty from the Transmit PDC channel is active.

- **ITER/UNRE: Max number of Repetitions Reached or SPI Underrun Error**

– If USART does not operate in SPI Slave Mode (MODE ... 0xF):

ITER = 0: Maximum number of repetitions has not been reached since the last RSTSTA.

ITER = 1: Maximum number of repetitions has been reached since the last RSTSTA.



– If USART operates in SPI Slave Mode (MODE = 0xF):

UNRE = 0: No SPI underrun error has occurred since the last RSTSTA.

UNRE = 1: At least one SPI underrun error has occurred since the last RSTSTA.

- **TXEMPTY: Transmitter Empty**

0: There are characters in either THR or the Transmit Shift Register, or the transmitter is disabled.

TXEMPTY == 1: Means that the Transmit Shift Register is empty and that there is no data in THR.

- **TIMEOUT: Receiver Time-out**

0: There has not been a time-out since the last Start Time-out command (STTTO in CR) or the Time-out Register is 0.

1: There has been a time-out since the last Start Time-out command (STTTO in CR).

- **PARE: Parity Error**

0: No parity error has been detected since the last RSTSTA.

1: At least one parity error has been detected since the last RSTSTA.

- **FRAME: Framing Error**

0: No stop bit has been detected low since the last RSTSTA.

1: At least one stop bit has been detected low since the last RSTSTA.

- **OVRE: Overrun Error**

0: No overrun error has occurred since the last RSTSTA.

1: At least one overrun error has occurred since the last RSTSTA.

- **ENDTX: End of Transmitter Transfer**

0: The End of Transfer signal from the Transmit PDC channel is inactive.

1: The End of Transfer signal from the Transmit PDC channel is active.

- **ENDRX: End of Receiver Transfer**

0: The End of Transfer signal from the Receive PDC channel is inactive.

1: The End of Transfer signal from the Receive PDC channel is active.

- **RXBRK: Break Received/End of Break**

0: No Break received or End of Break detected since the last RSTSTA.

1: Break Received or End of Break detected since the last RSTSTA.

- **TXRDY: Transmitter Ready**

0: A character is in the THR waiting to be transferred to the Transmit Shift Register, or an STTBRK command has been requested, or the transmitter is disabled. As soon as the transmitter is enabled, TXRDY becomes 1.

1: There is no character in the THR.

- **RXRDY: Receiver Ready**

0: No complete character has been received since the last read of RHR or the receiver is disabled. If characters were being received when the receiver was disabled, RXRDY changes to 1 when the receiver is enabled.

1: At least one complete character has been received and RHR has not yet been read.

## 26.8.8 USART Receive Holding Register

**Name:** RHR  
**Access Type:** Read-only  
**Offset:** 0x18  
**Reset Value:** 0x00000000

31	30	29	28	27	26	25	24
–	–	–	–	–	–	–	–
23	22	21	20	19	18	17	16
–	–	–	–	–	–	–	–
15	14	13	12	11	10	9	8
RXSYNH	–	–	–	–	–	–	RXCHR
7	6	5	4	3	2	1	0
RXCHR							

- **RXSYNH: Received Sync**

0: Last Character received is a Data.

1: Last Character received is a Command.

- **RXCHR: Received Character**

Last character received if RXRDY is set.

## 26.8.9 USART Transmit Holding Register

**Name:** THR  
**Access Type:** Write-only  
**Offset:** 0x1C  
**Reset Value:** -

31	30	29	28	27	26	25	24
-	-	-	-	-	-	-	-
23	22	21	20	19	18	17	16
-	-	-	-	-	-	-	-
15	14	13	12	11	10	9	8
TXSYNH	-	-	-	-	-	-	TXCHR
7	6	5	4	3	2	1	0
TXCHR							

- **TXSYNH: Sync Field to be transmitted**

0: The next character sent is encoded as a data. Start Frame Delimiter is DATA SYNC.

1: The next character sent is encoded as a command. Start Frame Delimiter is COMMAND SYNC.

- **TXCHR: Character to be Transmitted**

Next character to be transmitted after the current character if TXRDY is not set.

## 26.8.10 USART Baud Rate Generator Register

**Name:** BRGR  
**Access Type:** Read-write  
**Offset:** 0x20  
**Reset Value:** 0x00000000

31	30	29	28	27	26	25	24
–	–	–	–	–	–	–	–
23	22	21	20	19	18	17	16
–	–	–	–	–	FP–		
15	14	13	12	11	10	9	8
CD							
7	6	5	4	3	2	1	0
CD							

- FP: Fractional Part**

0: Fractional divider is disabled.

1 - 7: Baudrate resolution, defined by  $FP \times 1/8$ .

- CD: Clock Divider**

CD	MODE $\neq$ ISO7816			MODE = ISO7816
	SYNC = 0		SYNC = 1 or MODE = SPI (Master or Slave)	
	OVER = 0	OVER = 1		
0	Baud Rate Clock Disabled			
1 to 65535	Baud Rate = Selected Clock/16/CD	Baud Rate = Selected Clock/8/CD	Baud Rate = Selected Clock /CD	Baud Rate = Selected Clock/CD/FI_DI_RATIO

## 26.8.11 USART Receiver Time-out Register

**Name:** RTOR  
**Access Type:** Read-write  
**Offset:** 0x24  
**Reset Value:** 0x00000000

31	30	29	28	27	26	25	24
–	–	–	–	–	–	–	–
23	22	21	20	19	18	17	16
–	–	–	–	–	–	–	–
15	14	13	12	11	10	9	8
TO							
7	6	5	4	3	2	1	0
TO							

- **TO: Time-out Value**

0: The Receiver Time-out is disabled.

1 - 65535: The Receiver Time-out is enabled and the Time-out delay is TO x Bit Period.

## 26.8.12 USART Transmitter Timeguard Register

**Name:** TTGR  
**Access Type:** Read-write  
**Offset:** 0x28  
**Reset Value:** 0x00000000

31	30	29	28	27	26	25	24
-	-	-	-	-	-	-	-
23	22	21	20	19	18	17	16
-	-	-	-	-	-	-	-
15	14	13	12	11	10	9	8
-	-	-	-	-	-	-	-
7	6	5	4	3	2	1	0
TG							

- **TG: Timeguard Value**

0: The Transmitter Timeguard is disabled.

1 - 255: The Transmitter timeguard is enabled and the timeguard delay is TG x Bit Period.

## 26.8.13 USART FI DI RATIO Register

**Name:** FIDI  
**Access Type:** Read-write  
**Offset:** 0x40  
**Reset Value:** 0x00000174

31	30	29	28	27	26	25	24
-	-	-	-	-	-	-	-
23	22	21	20	19	18	17	16
-	-	-	-	-	-	-	-
15	14	13	12	11	10	9	8
-	-	-	-	-	FI_DI_RATIO		
7	6	5	4	3	2	1	0
FI_DI_RATIO							

- **FI\_DI\_RATIO: FI Over DI Ratio Value**

0: If ISO7816 mode is selected, the Baud Rate Generator generates no signal.

1 - 2047: If ISO7816 mode is selected, the Baud Rate is the clock provided on CLK divided by FI\_DI\_RATIO.



## 26.8.14 USART Number of Errors Register

**Name:** NER  
**Access Type:** Read-only  
**Offset:** 0x44  
**Reset Value:** -

31	30	29	28	27	26	25	24
-	-	-	-	-	-	-	-
23	22	21	20	19	18	17	16
-	-	-	-	-	-	-	-
15	14	13	12	11	10	9	8
-	-	-	-	-	-	-	-
7	6	5	4	3	2	1	0
NB_ERRORS							

- **NB\_ERRORS: Number of Errors**

Total number of errors that occurred during an ISO7816 transfer. This register automatically clears when read.

## 26.8.15 USART IrDA FILTER Register

**Name:** IFR  
**Access Type:** Read-write  
**Offset:** 0x4C  
**Reset Value:** 0x00000000

31	30	29	28	27	26	25	24
-	-	-	-	-	-	-	-
23	22	21	20	19	18	17	16
-	-	-	-	-	-	-	-
15	14	13	12	11	10	9	8
-	-	-	-	-	-	-	-
7	6	5	4	3	2	1	0
IRDA_FILTER							

- **IRDA\_FILTER: IrDA Filter**

Sets the filter of the IrDA demodulator.

## 26.8.16 USART Manchester Configuration Register

**Name:** MAN  
**Access Type:** Read-write  
**Offset:** 0x50  
**Reset Value:** 0x30011004

31	30	29	28	27	26	25	24	
-	DRIFT	1	RX_MPOL	-	-	RX_PP		
23	22	21	20	19	18	17	16	
-	-	-	-	RX_PL				-
15	14	13	12	11	10	9	8	
-	-	-	TX_MPOL	-	-	TX_PP		
7	6	5	4	3	2	1	0	
-	-	-	-	TX_PL				-

- **DRIFT: Drift compensation**

0: The USART can not recover from an important clock drift

1: The USART can recover from clock drift. The 16X clock mode must be enabled.

- **RX\_MPOL: Receiver Manchester Polarity**

0: Logic Zero is coded as a zero-to-one transition, Logic One is coded as a one-to-zero transition.

1: Logic Zero is coded as a one-to-zero transition, Logic One is coded as a zero-to-one transition.

- **RX\_PP: Receiver Preamble Pattern detected**

RX_PP		Preamble Pattern default polarity assumed (RX_MPOL field not set)
0	0	ALL_ONE
0	1	ALL_ZERO
1	0	ZERO_ONE
1	1	ONE_ZERO

- **RX\_PL: Receiver Preamble Length**

0: The receiver preamble pattern detection is disabled

1 - 15: The detected preamble length is RX\_PL x Bit Period

- **TX\_MPOL: Transmitter Manchester Polarity**

0: Logic Zero is coded as a zero-to-one transition, Logic One is coded as a one-to-zero transition.

1: Logic Zero is coded as a one-to-zero transition, Logic One is coded as a zero-to-one transition.

- **TX\_PP: Transmitter Preamble Pattern**

TX_PP		Preamble Pattern default polarity assumed (TX_MPOL field not set)
0	0	ALL_ONE
0	1	ALL_ZERO
1	0	ZERO_ONE
1	1	ONE_ZERO

- **TX\_PL: Transmitter Preamble Length**

0: The Transmitter Preamble pattern generation is disabled

1 - 15: The Preamble Length is TX\_PL x Bit Period

## 26.8.17 USART Version Register

**Name:** VERSION  
**Access Type:** Read-only  
**Offset:** 0xFC  
**Reset Value:** 0x00000000

31	30	29	28	27	26	25	24
-	-	-	-	-	-	-	-
23	22	21	20	19	18	17	16
-	-	-	-	-	VARIANT		
15	14	13	12	11	10	9	8
-	-	-	-	VERSION			
7	6	5	4	3	2	1	0
VERSION							

- **VARIANT**

Reserved. No functionality associated.

- **VERSION**

Version of the module. No functionality associated.

## 27. Static Memory Controller (SMC)

Rev. 1.0.0.0

### 27.1 Features

- 4 Chip Selects Available
- 64-Mbyte Address Space per Chip Select
- 8-, 16- or 32-bit Data Bus
- Word, Halfword, Byte Transfers
- Byte Write or Byte Select Lines
- Programmable Setup, Pulse And Hold Time for Read Signals per Chip Select
- Programmable Setup, Pulse And Hold Time for Write Signals per Chip Select
- Programmable Data Float Time per Chip Select
- Compliant with LCD Module
- External Wait Request
- Automatic Switch to Slow Clock Mode
- Asynchronous Read in Page Mode Supported: Page Size Ranges from 4 to 32 Bytes

### 27.2 Overview

The Static Memory Controller (SMC) generates the signals that control the access to the external memory devices or peripheral devices. It has 4 Chip Selects and a 26-bit address bus. The 32-bit data bus can be configured to interface with 8-, or 16-, or 32-bit external devices. Separate read and write control signals allow for direct memory and peripheral interfacing. Read and write signal waveforms are fully parametrizable.

The SMC can manage wait requests from external devices to extend the current access. The SMC is provided with an automatic slow clock mode. In slow clock mode, it switches from user-programmed waveforms to slow-rate specific waveforms on read and write signals. The SMC supports asynchronous burst read in page mode access for page size up to 32 bytes.

## 27.3 Block Diagram

Figure 27-1. Block Diagram

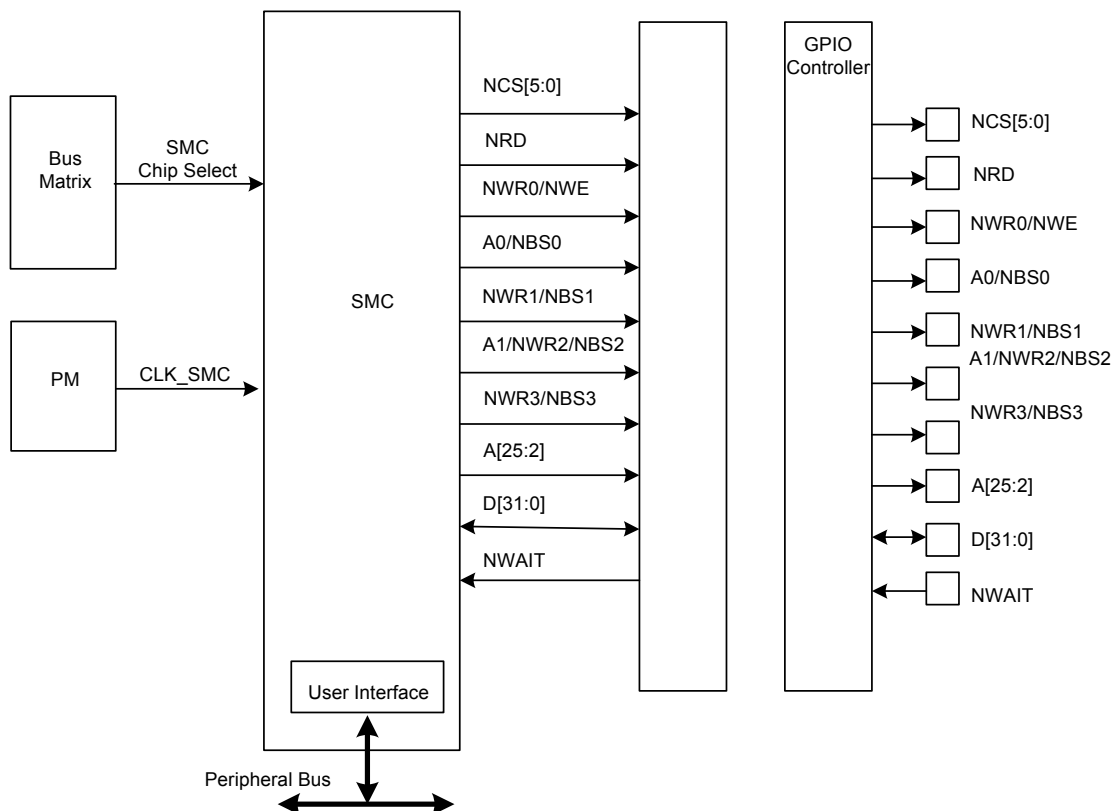

## 27.4 I/O Lines Description

Table 27-1. I/O Line Description

Name	Description	Type	Active Level
NCS[3:0]	Static Memory Controller Chip Select Lines	Output	Low
NRD	Read Signal	Output	Low
NWR0/NWE	Write 0/Write Enable Signal	Output	Low
A0/NBS0	Address Bit 0/Byte 0 Select Signal	Output	Low
NWR1/NBS1	Write 1/Byte 1 Select Signal	Output	Low
A1/NWR2/NBS2	Address Bit 1/Write 2/Byte 2 Select Signal	Output	Low
NWR3/NBS3	Write 3/Byte 3 Select Signal	Output	Low
A[25:2]	Address Bus	Output	
D[31:0]	Data Bus	I/O	
NWAIT	External Wait Signal	Input	Low

## 27.5 Product Dependencies

### 27.5.1 EBI I/O Lines

The Static Memory Controller signals pass through the EBI module where they are multiplexed. The programmer must first configure the GPIO controller to assign the EBI pins corresponding to SMC signals to their peripheral function. If I/O lines of the EBI corresponding to SMC signals are not used by the application, they can be used for other purposes by the GPIO Controller.

## 27.6 Functional Description

### 27.6.1 Application Example

#### 27.6.1.1 Hardware Interface

**Figure 27-2.** SMC Connections to Static Memory Devices

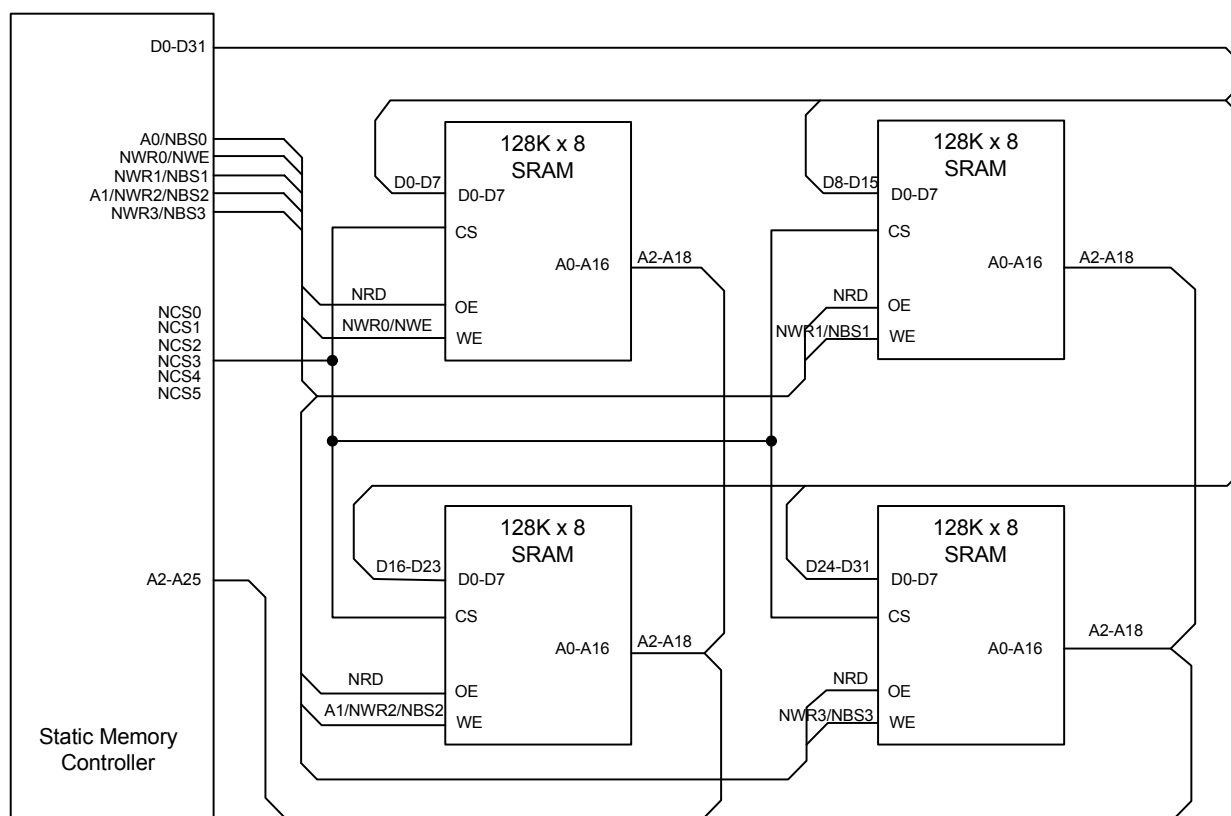

### 27.6.2 External Memory Mapping

The SMC provides up to 26 address lines, A[25:0]. This allows each chip select line to address up to 64 Mbytes of memory.



If the physical memory device connected on one chip select is smaller than 64 Mbytes, it wraps around and appears to be repeated within this space. The SMC correctly handles any valid access to the memory device within the page (see [Figure 27-3](#)).

A[25:0] is only significant for 8-bit memory, A[25:1] is used for 16-bit memory, A[25:2] is used for 32-bit memory.

**Figure 27-3.** Memory Connections for 6 External Devices

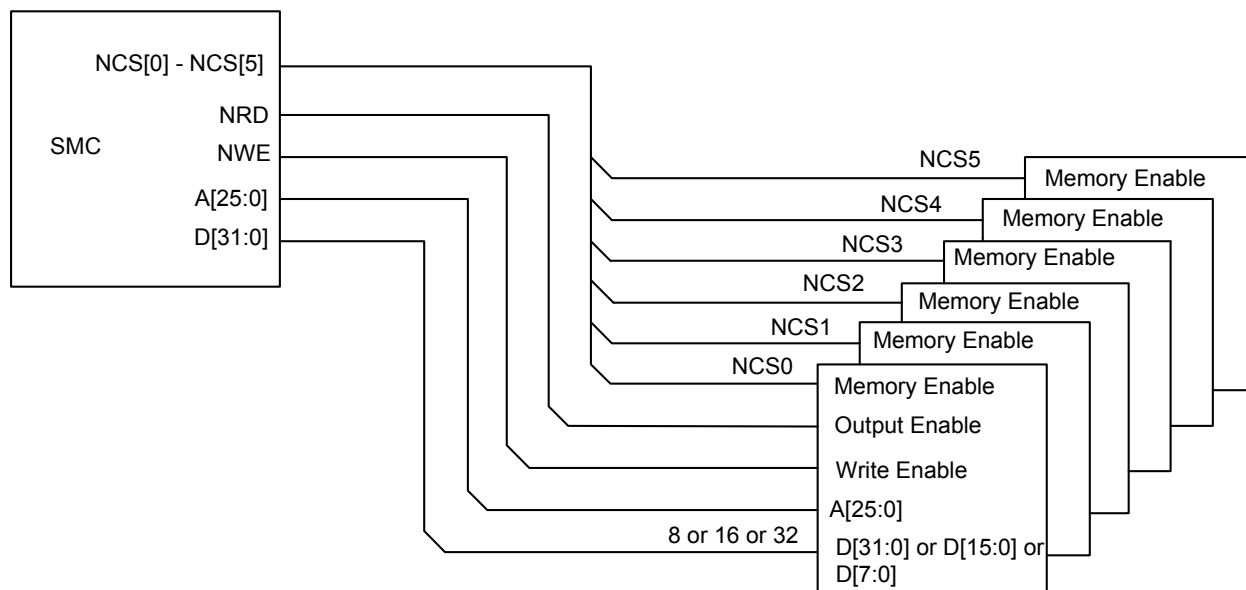

## 27.6.3 Connection to External Devices

### 27.6.3.1 Data Bus Width

A data bus width of 8, 16 or 32 bits can be selected for each chip select. This option is controlled by the field DBW in MODE (Mode Register) for the corresponding chip select.

[Figure 27-4](#) shows how to connect a 512K x 8-bit memory on NCS2. [Figure 27-5](#) shows how to connect a 512K x 16-bit memory on NCS2. [Figure 27-6](#) shows two 16-bit memories connected as a single 32-bit memory.

### 27.6.3.2 Byte Write or Byte Select Access

Each chip select with a 16-bit or 32-bit data bus can operate with one of two different types of write access: byte write or byte select access. This is controlled by the BAT field of the MODE register for the corresponding chip select.

**Figure 27-4.** Memory Connection for an 8-bit Data Bus

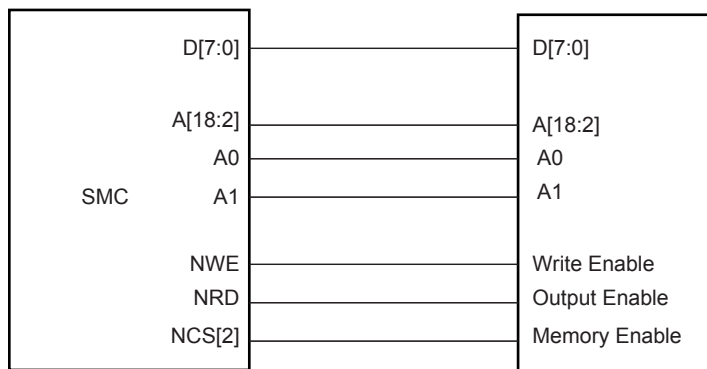

**Figure 27-5.** Memory Connection for a 16-bit Data Bus

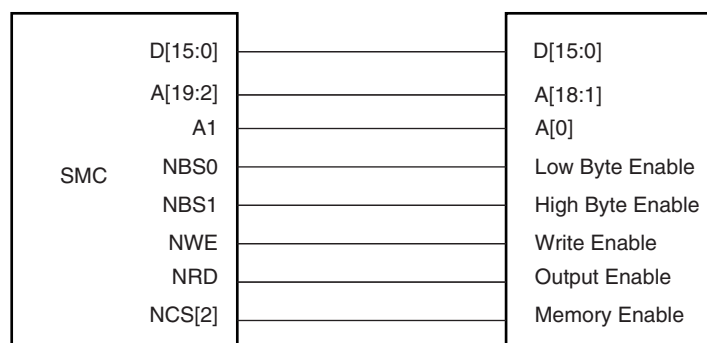

**Figure 27-6.** Memory Connection for a 32-bit Data Bus

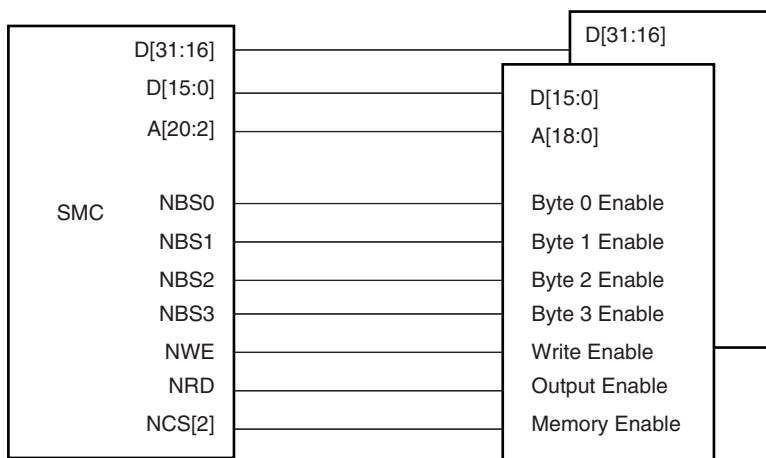

### – Byte Write Access

Byte write access supports one byte write signal per byte of the data bus and a single read signal.

Note that the SMC does not allow boot in Byte Write Access mode.

- For 16-bit devices: the SMC provides NWR0 and NWR1 write signals for respectively byte0 (lower byte) and byte1 (upper byte) of a 16-bit bus. One single read signal (NRD) is provided.

Byte Write Access is used to connect 2 x 8-bit devices as a 16-bit memory.

- For 32-bit devices: NWR0, NWR1, NWR2 and NWR3, are the write signals of byte0 (lower byte), byte1, byte2 and byte 3 (upper byte) respectively. One single read signal (NRD) is provided.

Byte Write Access is used to connect 4 x 8-bit devices as a 32-bit memory.

Byte Write option is illustrated on [Figure 27-7](#).

### – Byte Select Access

In this mode, read/write operations can be enabled/disabled at a byte level. One byte-select line per byte of the data bus is provided. One NRD and one NWE signal control read and write.

- For 16-bit devices: the SMC provides NBS0 and NBS1 selection signals for respectively byte0 (lower byte) and byte1 (upper byte) of a 16-bit bus.

Byte Select Access is used to connect one 16-bit device.

- For 32-bit devices: NBS0, NBS1, NBS2 and NBS3, are the selection signals of byte0 (lower byte), byte1, byte2 and byte 3 (upper byte) respectively. Byte Select Access is used to connect two 16-bit devices.

[Figure 27-8](#) shows how to connect two 16-bit devices on a 32-bit data bus in Byte Select Access mode, on NCS3 (BAT = Byte Select Access).

Figure 27-7. Connection of 2 x 8-bit Devices on a 16-bit Bus: Byte Write Option

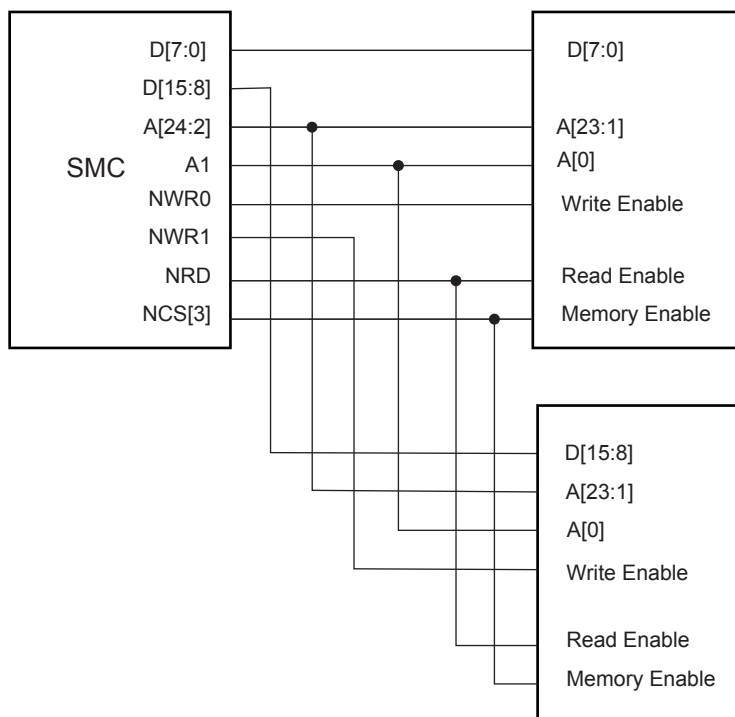

– Signal Multiplexing

Depending on the BAT, only the write signals or the byte select signals are used. To save IOs at the external bus interface, control signals at the SMC interface are multiplexed.

For 32-bit devices, bits A0 and A1 are unused. For 16-bit devices, bit A0 of address is unused. When Byte Select Option is selected, NWR1 to NWR3 are unused. When Byte Write option is selected, NBS0 to NBS3 are unused.

**Figure 27-8.** Connection of 2x16-bit Data Bus on a 32-bit Data Bus (Byte Select Option)

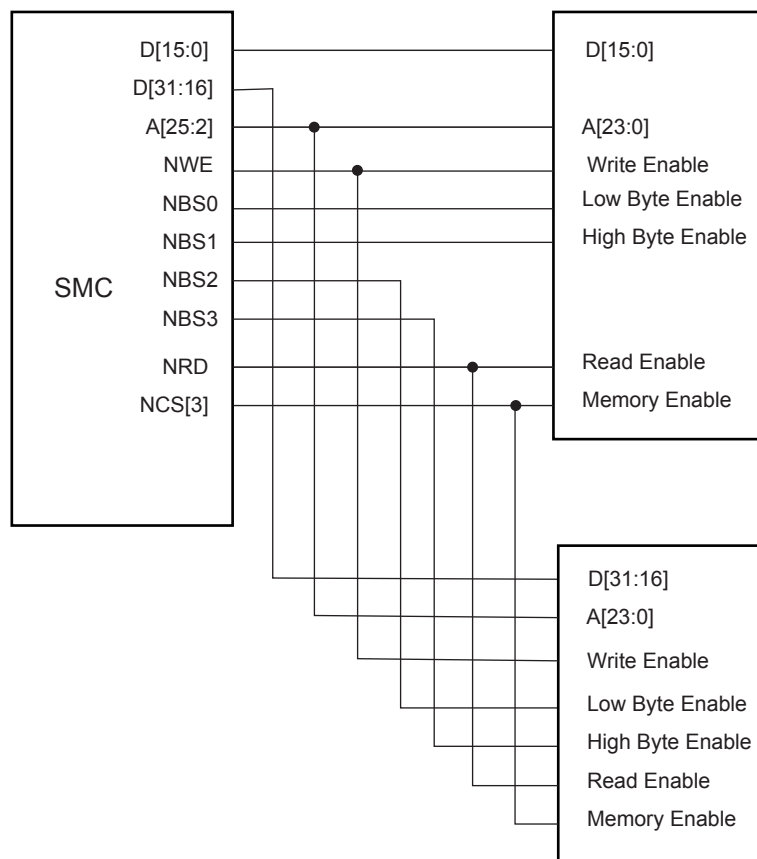

**Table 27-2.** SMC Multiplexed Signal Translation

Signal Name	32-bit Bus			16-bit Bus		8-bit Bus
	1x32-bit	2x16-bit	4 x 8-bit	1x16-bit	2 x 8-bit	1 x 8-bit
Byte Access Type (BAT)	Byte Select	Byte Select	Byte Write	Byte Select	Byte Write	
NBS0_A0	NBS0	NBS0		NBS0		A0
NWE_NWR0	NWE	NWE	NWR0	NWE	NWR0	NWE
NBS1_NWR1	NBS1	NBS1	NWR1	NBS1	NWR1	
NBS2_NWR2_A1	NBS2	NBS2	NWR2	A1	A1	A1
NBS3_NWR3	NBS3	NBS3	NWR3			

### 27.6.4 Standard Read and Write Protocols

In the following sections, the byte access type is not considered. Byte select lines (NBS0 to NBS3) always have the same timing as the A address bus. NWE represents either the NWE signal in byte select access type or one of the byte write lines (NWR0 to NWR3) in byte write access type. NWR0 to NWR3 have the same timings and protocol as NWE. In the same way, NCS represents one of the NCS[0..3] chip select lines.

## 27.6.4.1 Read Waveforms

The read cycle is shown on [Figure 27-9](#).

The read cycle starts with the address setting on the memory address bus, i.e.:

{A[25:2], A1, A0} for 8-bit devices

{A[25:2], A1} for 16-bit devices

A[25:2] for 32-bit devices.

**Figure 27-9.** Standard Read Cycle

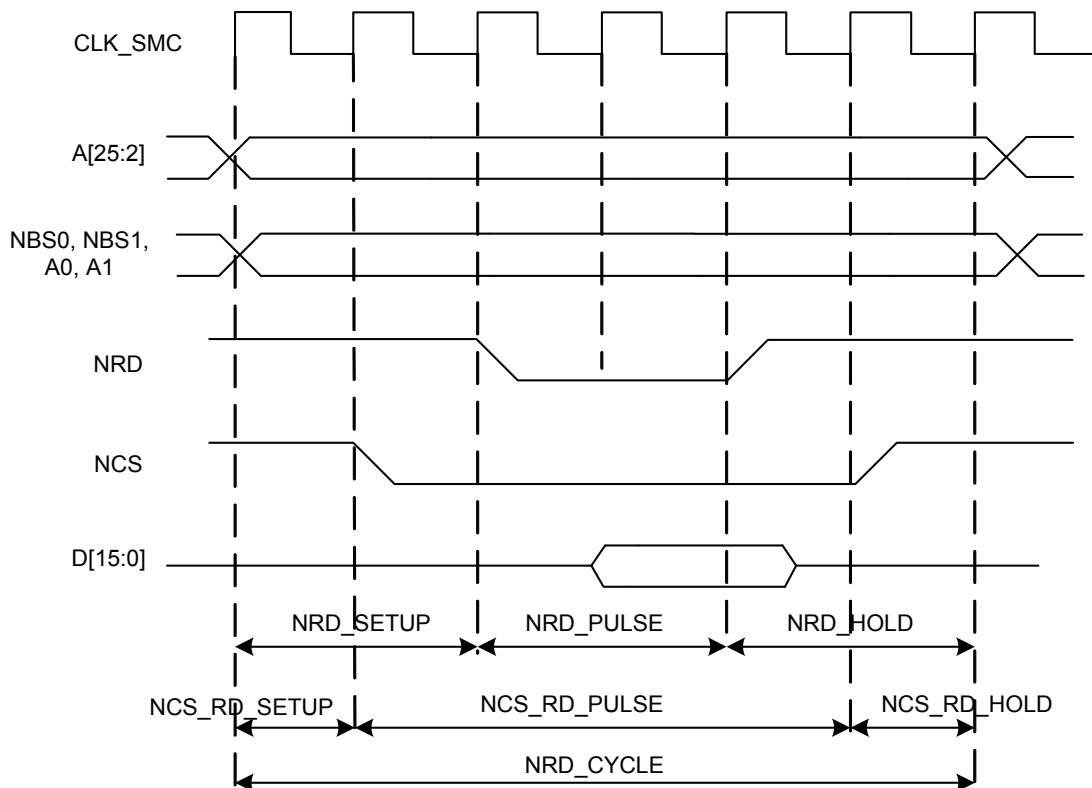

### – NRD Waveform

The NRD signal is characterized by a setup timing, a pulse width and a hold timing.

1. **NRD\_SETUP:** the NRD setup time is defined as the setup of address before the NRD falling edge;
2. **NRD\_PULSE:** the NRD pulse length is the time between NRD falling edge and NRD rising edge;
3. **NRD\_HOLD:** the NRD hold time is defined as the hold time of address after the NRD rising edge.

### – NCS Waveform

Similarly, the NCS signal can be divided into a setup time, pulse length and hold time:

1. NCS\_RD\_SETUP: the NCS setup time is defined as the setup time of address before the NCS falling edge.
2. NCS\_RD\_PULSE: the NCS pulse length is the time between NCS falling edge and NCS rising edge;
3. NCS\_RD\_HOLD: the NCS hold time is defined as the hold time of address after the NCS rising edge.

### – Read Cycle

The NRD\_CYCLE time is defined as the total duration of the read cycle, i.e., from the time where address is set on the address bus to the point where address may change. The total read cycle time is equal to:

$$\begin{aligned} \text{NRD\_CYCLE} &= \text{NRD\_SETUP} + \text{NRD\_PULSE} + \text{NRD\_HOLD} \\ &= \text{NCS\_RD\_SETUP} + \text{NCS\_RD\_PULSE} + \text{NCS\_RD\_HOLD} \end{aligned}$$

All NRD and NCS timings are defined separately for each chip select as an integer number of Master Clock cycles. To ensure that the NRD and NCS timings are coherent, user must define the total read cycle instead of the hold timing. NRD\_CYCLE implicitly defines the NRD hold time and NCS hold time as:

$$\begin{aligned} \text{NRD\_HOLD} &= \text{NRD\_CYCLE} - \text{NRD\_SETUP} - \text{NRD\_PULSE} \\ \text{NCS\_RD\_HOLD} &= \text{NRD\_CYCLE} - \text{NCS\_RD\_SETUP} - \text{NCS\_RD\_PULSE} \end{aligned}$$

### – Null Delay Setup and Hold

If null setup and hold parameters are programmed for NRD and/or NCS, NRD and NCS remain active continuously in case of consecutive read cycles in the same memory (see [Figure 27-10](#)).

Figure 27-10. No Setup, No Hold On NRD and NCS Read Signals

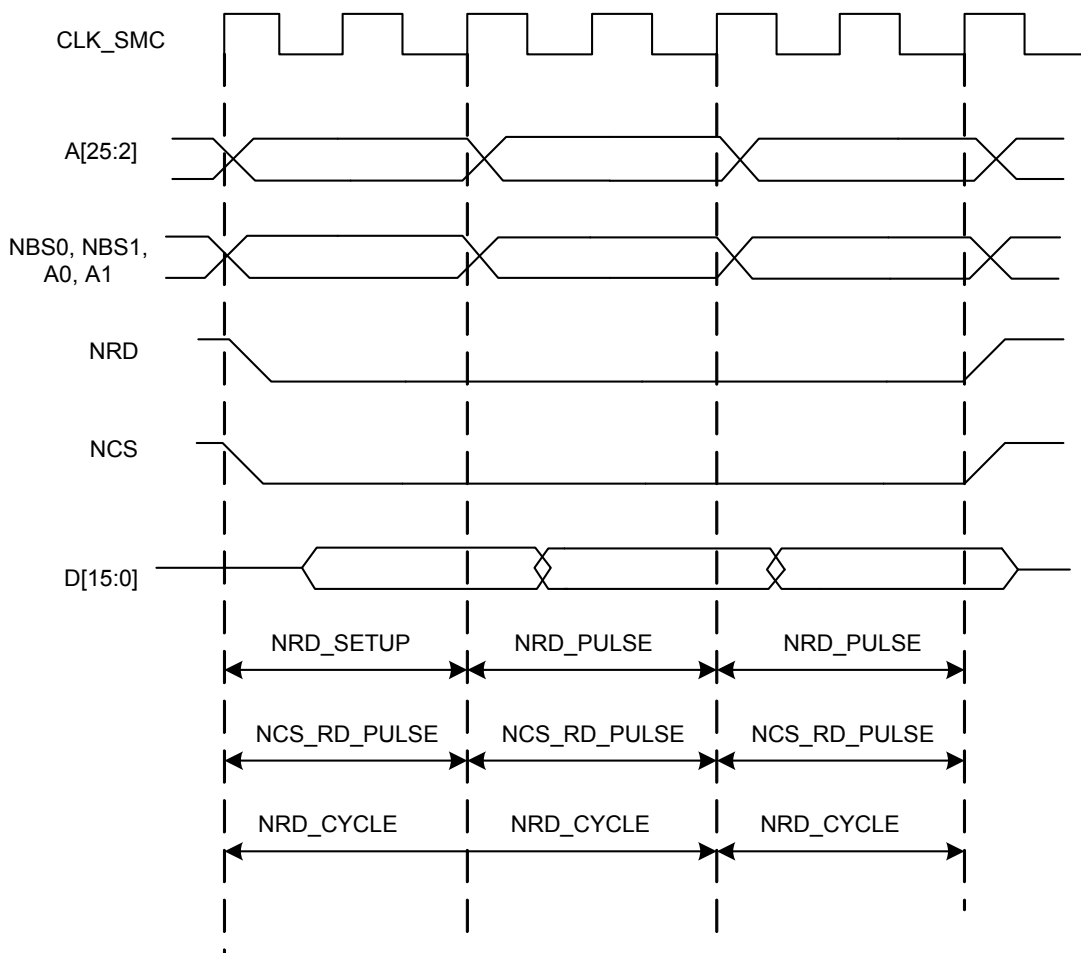

– Null Pulse

Programming null pulse is not permitted. Pulse must be at least set to 1. A null value leads to unpredictable behavior.

27.6.4.2 Read Mode

As NCS and NRD waveforms are defined independently of one other, the SMC needs to know when the read data is available on the data bus. The SMC does not compare NCS and NRD timings to know which signal rises first. The READ\_MODE parameter in the MODE register of the corresponding chip select indicates which signal of NRD and NCS controls the read operation.

– Read is Controlled by NRD (READ\_MODE = 1):

Figure 27-11 shows the waveforms of a read operation of a typical asynchronous RAM. The read data is available  $t_{PACC}$  after the falling edge of NRD, and turns to 'Z' after the rising edge of NRD. In this case, the READ\_MODE must be set to 1 (read is controlled by NRD), to indicate that data is available with the rising edge of NRD. The SMC samples the read data internally on the rising edge of Master Clock that generates the rising edge of NRD, whatever the programmed waveform of NCS may be.



**Figure 27-11.** READ\_MODE = 1: Data is sampled by SMC before the rising edge of NRD

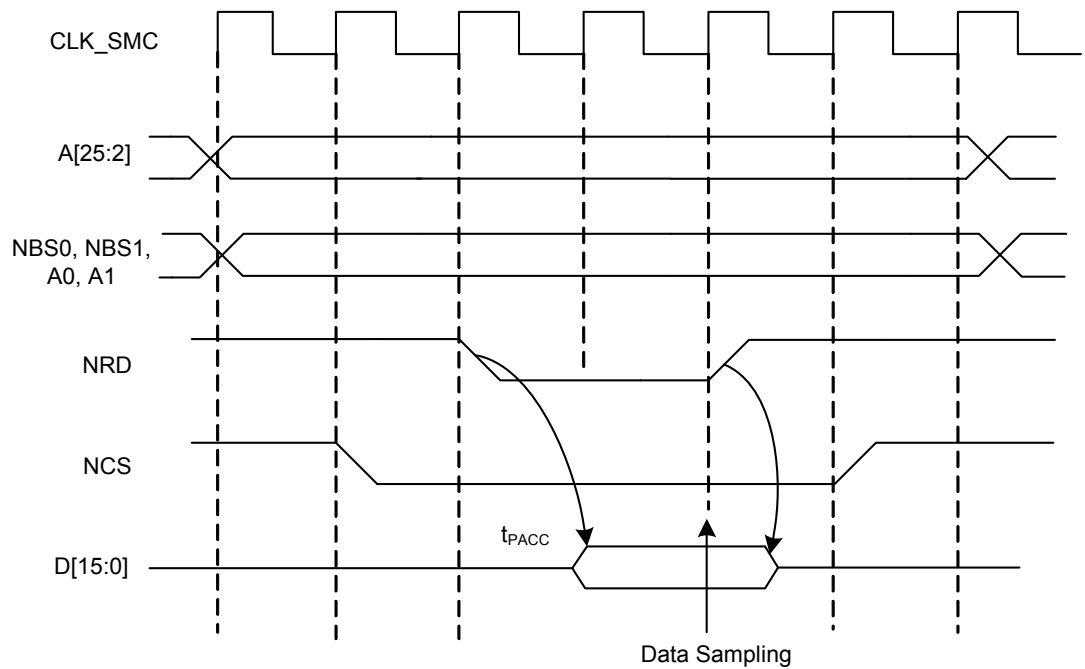

**– Read is Controlled by NCS (READ\_MODE = 0)**

Figure 27-12 shows the typical read cycle of an LCD module. The read data is valid  $t_{PACC}$  after the falling edge of the NCS signal and remains valid until the rising edge of NCS. Data must be sampled when NCS is raised. In that case, the READ\_MODE must be set to 0 (read is controlled by NCS): the SMC internally samples the data on the rising edge of Master Clock that generates the rising edge of NCS, whatever the programmed waveform of NRD may be.

**Figure 27-12.** READ\_MODE = 0: Data is sampled by SMC before the rising edge of NCS

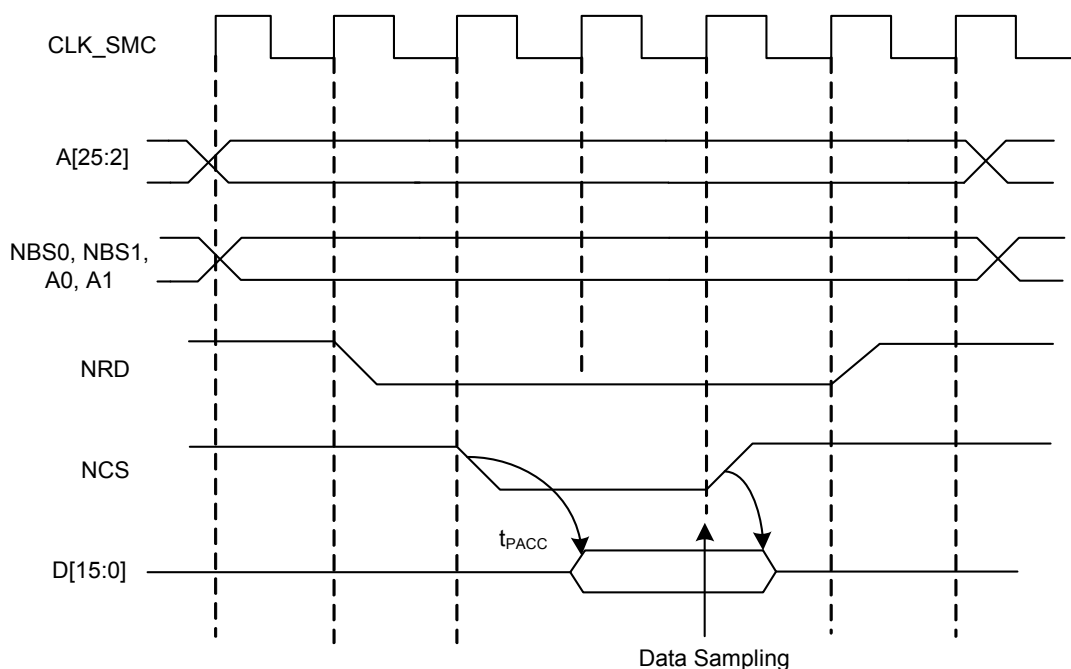

### 27.6.4.3 Write Waveforms

The write protocol is similar to the read protocol. It is depicted in [Figure 27-13](#). The write cycle starts with the address setting on the memory address bus.

#### – NWE Waveforms

The NWE signal is characterized by a setup timing, a pulse width and a hold timing.

1. NWE\_SETUP: the NWE setup time is defined as the setup of address and data before the NWE falling edge;
2. NWE\_PULSE: The NWE pulse length is the time between NWE falling edge and NWE rising edge;
3. NWE\_HOLD: The NWE hold time is defined as the hold time of address and data after the NWE rising edge.

The NWE waveforms apply to all byte-write lines in Byte Write access mode: NWR0 to NWR3.

### 27.6.4.4 NCS Waveforms

The NCS signal waveforms in write operation are not the same that those applied in read operations, but are separately defined:

1. NCS\_WR\_SETUP: the NCS setup time is defined as the setup time of address before the NCS falling edge.
2. NCS\_WR\_PULSE: the NCS pulse length is the time between NCS falling edge and NCS rising edge;
3. NCS\_WR\_HOLD: the NCS hold time is defined as the hold time of address after the NCS rising edge.

**Figure 27-13. Write Cycle**

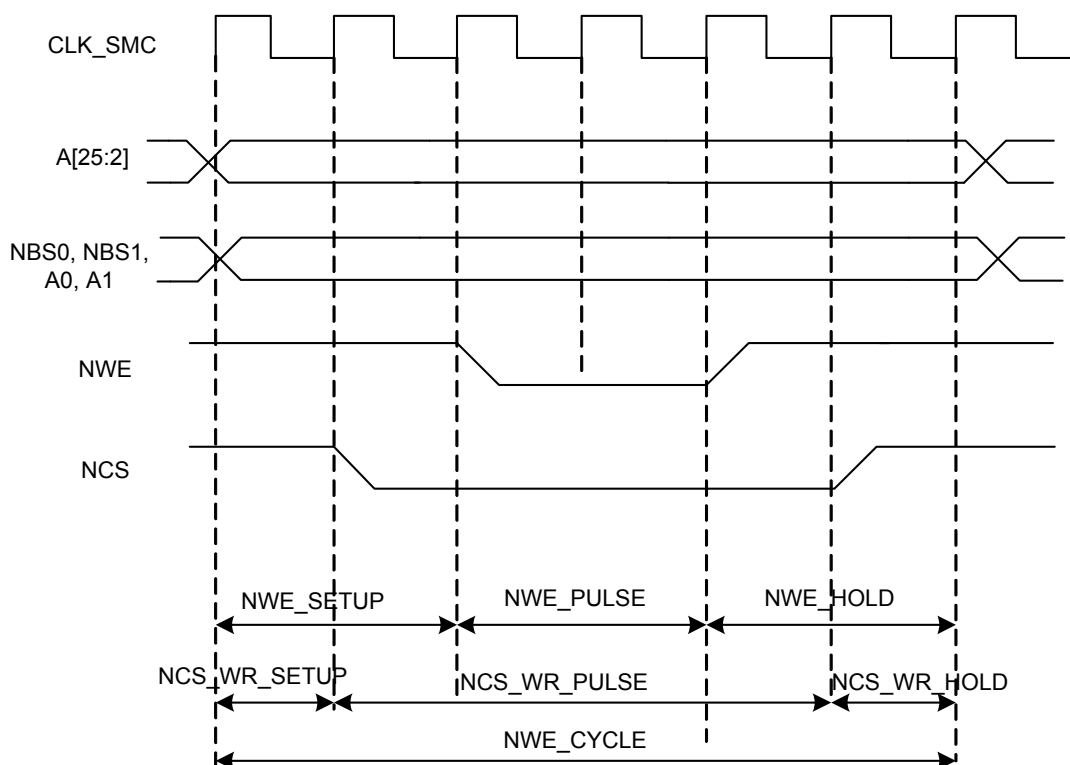

**– Write Cycle**

The write\_cycle time is defined as the total duration of the write cycle, that is, from the time where address is set on the address bus to the point where address may change. The total write cycle time is equal to:

$$\begin{aligned} \text{NWE\_CYCLE} &= \text{NWE\_SETUP} + \text{NWE\_PULSE} + \text{NWE\_HOLD} \\ &= \text{NCS\_WR\_SETUP} + \text{NCS\_WR\_PULSE} + \text{NCS\_WR\_HOLD} \end{aligned}$$

All NWE and NCS (write) timings are defined separately for each chip select as an integer number of Master Clock cycles. To ensure that the NWE and NCS timings are coherent, the user must define the total write cycle instead of the hold timing. This implicitly defines the NWE hold time and NCS (write) hold times as:

$$\begin{aligned} \text{NWE\_HOLD} &= \text{NWE\_CYCLE} - \text{NWE\_SETUP} - \text{NWE\_PULSE} \\ \text{NCS\_WR\_HOLD} &= \text{NWE\_CYCLE} - \text{NCS\_WR\_SETUP} - \text{NCS\_WR\_PULSE} \end{aligned}$$

**– Null Delay Setup and Hold**

If null setup parameters are programmed for NWE and/or NCS, NWE and/or NCS remain active continuously in case of consecutive write cycles in the same memory (see [Figure 27-14](#)). However, for devices that perform write operations on the rising edge of NWE or NCS, such as SRAM, either a setup or a hold must be programmed.

**Figure 27-14.** Null Setup and Hold Values of NCS and NWE in Write Cycle

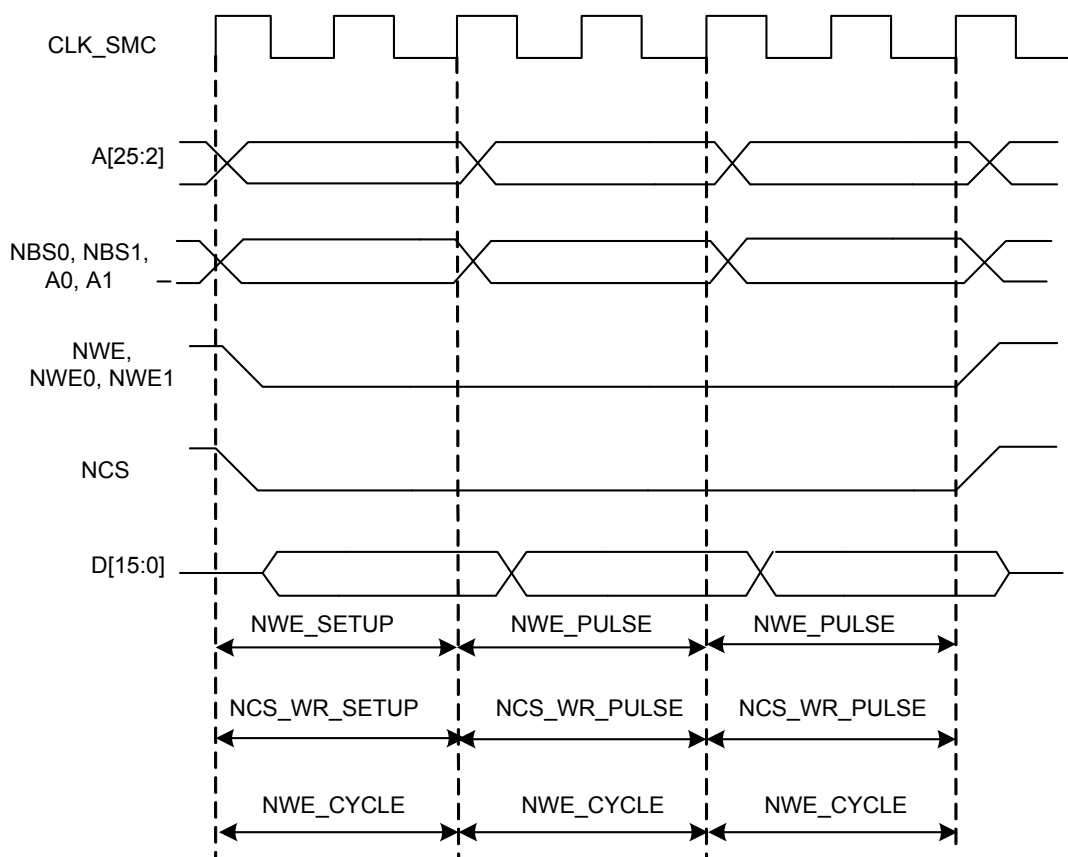

**– Null Pulse**

Programming null pulse is not permitted. Pulse must be at least set to 1. A null value leads to unpredictable behavior.

**27.6.4.5 Write Mode**

The `WRITE_MODE` parameter in the `MODE` register of the corresponding chip select indicates which signal controls the write operation.

**– Write is Controlled by NWE (`WRITE_MODE = 1`):**

Figure 27-15 shows the waveforms of a write operation with `WRITE_MODE` set to 1. The data is put on the bus during the pulse and hold steps of the NWE signal. The internal data buffers are turned out after the `NWE_SETUP` time, and until the end of the write cycle, regardless of the programmed waveform on NCS.

**Figure 27-15.** WRITE\_MODE = 1. The write operation is controlled by NWE

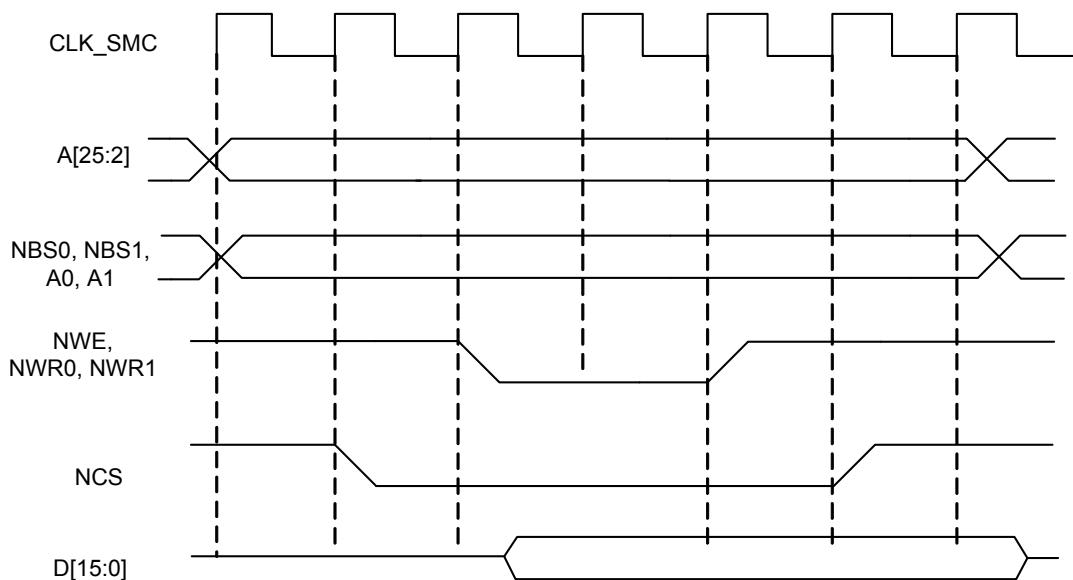

– Write is Controlled by NCS (WRITE\_MODE = 0)

Figure 27-16 shows the waveforms of a write operation with WRITE\_MODE set to 0. The data is put on the bus during the pulse and hold steps of the NCS signal. The internal data buffers are turned out after the NCS\_WR\_SETUP time, and until the end of the write cycle, regardless of the programmed waveform on NWE.

**Figure 27-16.** WRITE\_MODE = 0. The write operation is controlled by NCS

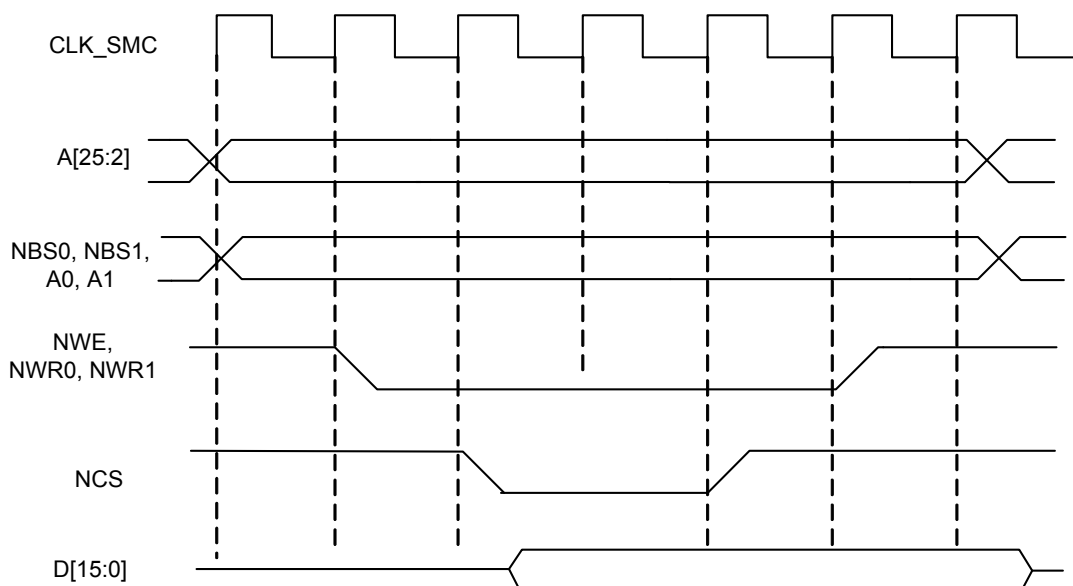

27.6.4.6 Coding Timing Parameters

All timing parameters are defined for one chip select and are grouped together in one REGISTER according to their type.

The SETUP register groups the definition of all setup parameters:

- NRD\_SETUP, NCS\_RD\_SETUP, NWE\_SETUP, NCS\_WR\_SETUP

The PULSE register groups the definition of all pulse parameters:

- NRD\_PULSE, ncs\_rd\_pULSE, nwe\_pULSE, ncs\_wr\_pULSE

The CYCLE register groups the definition of all cycle parameters:

- NRD\_CYCLE, NWE\_CYCLEe

Table 27-3 shows how the timing parameters are coded and their permitted range.

**Table 27-3.** Coding and Range of Timing Parameters

Coded Value	Number of Bits	Effective Value	Permitted Range	
			Coded Value	Effective Value
setup [5:0]	6	$128 \times \text{setup}[5] + \text{setup}[4:0]$	$0 \leq \leq 31$	$128 \leq \leq 128+31$
pulse [6:0]	7	$256 \times \text{pulse}[6] + \text{pulse}[5:0]$	$0 \leq \leq 63$	$256 \leq \leq 256+63$
cycle [8:0]	9	$256 \times \text{cycle}[8:7] + \text{cycle}[6:0]$	$0 \leq \leq 127$	$256 \leq \leq 256+127$
				$512 \leq \leq 512+127$
				$768 \leq \leq 768+127$

#### 27.6.4.7 Usage Restriction

**The SMC does not check the validity of the user-programmed parameters. If the sum of SETUP and PULSE parameters is larger than the corresponding CYCLE parameter, this leads to unpredictable behavior of the SMC.**

For read operations:

Null but positive setup and hold of address and NRD and/or NCS can not be guaranteed at the memory interface because of the propagation delay of these signals through external logic and pads. If positive setup and hold values must be verified, then it is strictly recommended to program non-null values so as to cover possible skews between address, NCS and NRD signals.

For write operations:

If a null hold value is programmed on NWE, the SMC can guarantee a positive hold of address, byte select lines, and NCS signal after the rising edge of NWE. This is true for WRITE\_MODE = 1 only. See "Early Read Wait State" on page 385.

For read and write operations: a null value for pulse parameters is forbidden and may lead to unpredictable behavior.

In read and write cycles, the setup and hold time parameters are defined in reference to the address bus. For external devices that require setup and hold time between NCS and NRD signals (read), or between NCS and NWE signals (write), these setup and hold times must be converted into setup and hold times in reference to the address bus.

#### 27.6.5 Automatic Wait States

Under certain circumstances, the SMC automatically inserts idle cycles between accesses to avoid bus contention or operation conflict.

### 27.6.5.1 *Chip Select Wait States*

The SMC always inserts an idle cycle between 2 transfers on separate chip selects. This idle cycle ensures that there is no bus contention between the de-activation of one device and the activation of the next one.

During chip select wait state, all control lines are turned inactive: NBS0 to NBS3, NWR0 to NWR3, NCS[0..5], NRD lines are all set to 1.

[Figure 27-17](#) illustrates a chip select wait state between access on Chip Select 0 and Chip Select 2.

**Figure 27-17.** Chip Select Wait State between a Read Access on NCS0 and a Write Access on NCS2

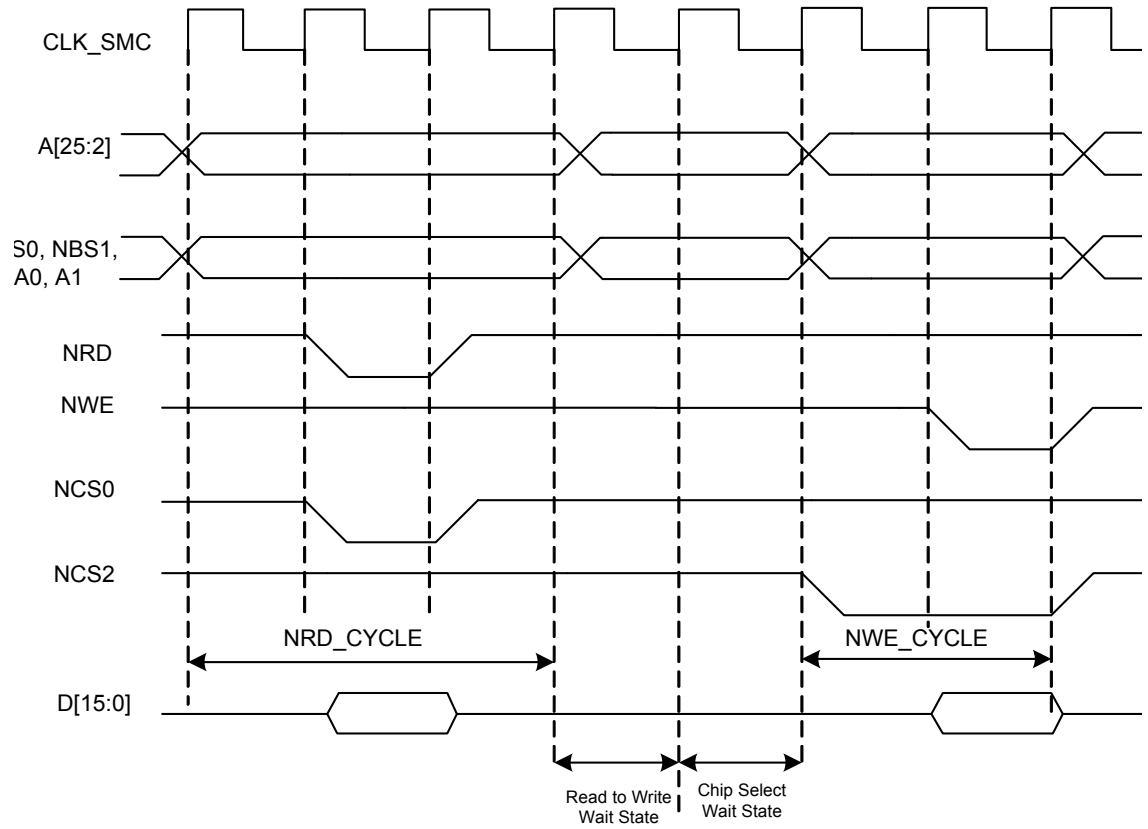



## 27.6.5.2 Early Read Wait State

In some cases, the SMC inserts a wait state cycle between a write access and a read access to allow time for the write cycle to end before the subsequent read cycle begins. This wait state is not generated in addition to a chip select wait state. The early read cycle thus only occurs between a write and read access to the same memory device (same chip select).

- An early read wait state is automatically inserted if at least one of the following conditions is valid:
  - if the write controlling signal has no hold time and the read controlling signal has no setup time (Figure 27-18).
  - in NCS write controlled mode (WRITE\_MODE = 0), if there is no hold timing on the NCS signal and the NCS\_RD\_SETUP parameter is set to 0, regardless of the read mode (Figure 27-19). The write operation must end with a NCS rising edge. Without an Early Read Wait State, the write operation could not complete properly.
  - in NWE controlled mode (WRITE\_MODE = 1) and if there is no hold timing (NWE\_HOLD = 0), the feedback of the write control signal is used to control address, data, chip select and byte select lines. If the external write control signal is not inactivated as expected due to load capacitances, an Early Read Wait State is inserted and address, data and control signals are maintained one more cycle. See Figure 27-20.

**Figure 27-18.** Early Read Wait State: Write with No Hold Followed by Read with No Setup.

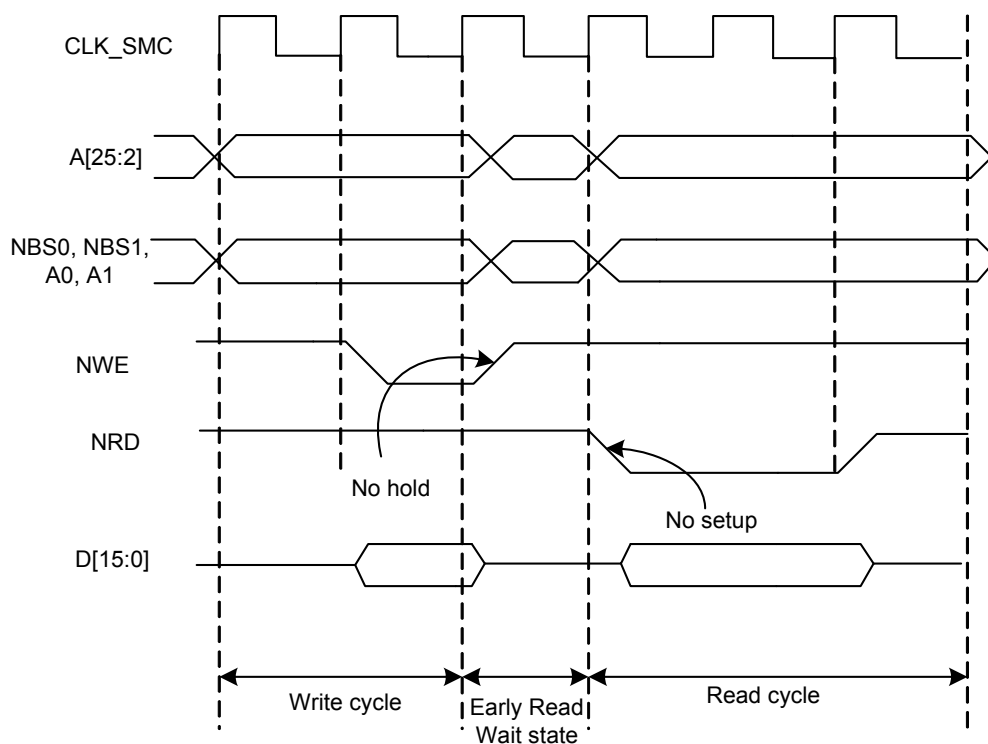

**Figure 27-19.** Early Read Wait State: NCS Controlled Write with No Hold Followed by a Read with No Setup.

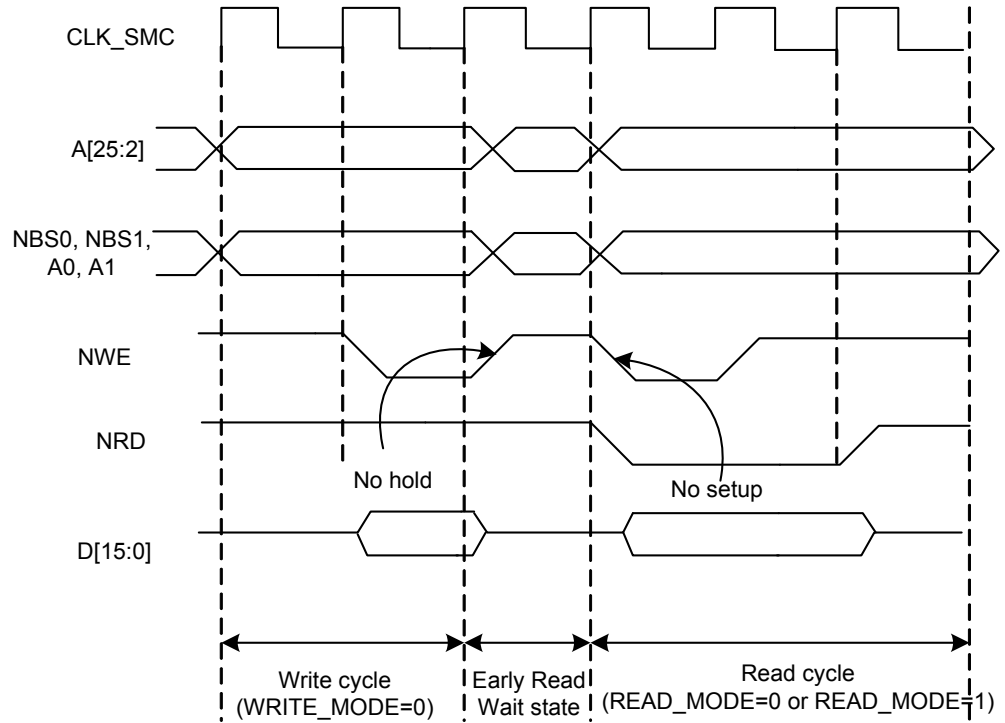

**Figure 27-20.** Early Read Wait State: NWE-controlled Write with No Hold Followed by a Read with one Set-up Cycle.

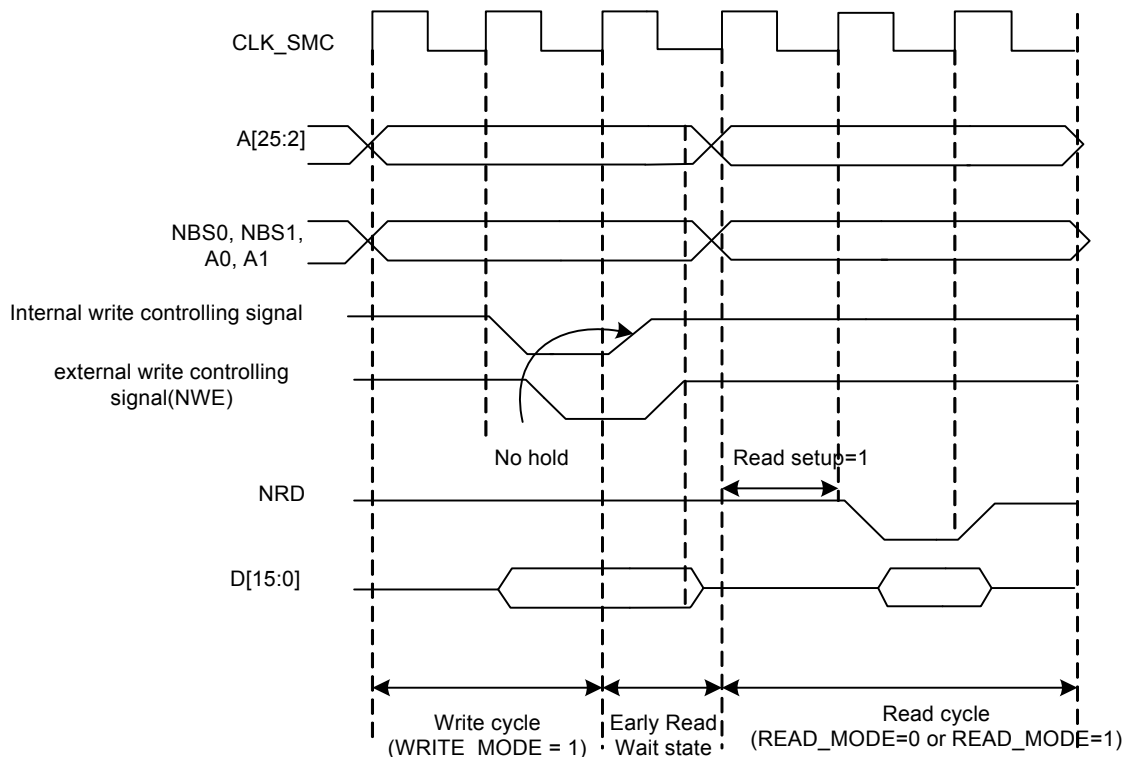

### 27.6.5.3 Reload User Configuration Wait State

The user may change any of the configuration parameters by writing the SMC user interface.

When detecting that a new user configuration has been written in the user interface, the SMC inserts a wait state before starting the next access. The so called “Reload User Configuration Wait State” is used by the SMC to load the new set of parameters to apply to next accesses.

The Reload Configuration Wait State is not applied in addition to the Chip Select Wait State. If accesses before and after re-programming the user interface are made to different devices (Chip Selects), then one single Chip Select Wait State is applied.

On the other hand, if accesses before and after writing the user interface are made to the same device, a Reload Configuration Wait State is inserted, even if the change does not concern the current Chip Select.

#### – User Procedure

To insert a Reload Configuration Wait State, the SMC detects a write access to any MODE register of the user interface. If the user only modifies timing registers (SETUP, PULSE, CYCLE registers) in the user interface, he must validate the modification by writing the MODE, even if no change was made on the mode parameters.

#### – Slow Clock Mode Transition

A Reload Configuration Wait State is also inserted when the Slow Clock Mode is entered or exited, after the end of the current transfer (see “Slow Clock Mode” on page 398).

#### 27.6.5.4 Read to Write Wait State

Due to an internal mechanism, a wait cycle is always inserted between consecutive read and write SMC accesses.

This wait cycle is referred to as a read to write wait state in this document.

This wait cycle is applied in addition to chip select and reload user configuration wait states when they are to be inserted. See [Figure 27-17 on page 384](#).

#### 27.6.6 Data Float Wait States

Some memory devices are slow to release the external bus. For such devices, it is necessary to add wait states (data float wait states) after a read access:

- before starting a read access to a different external memory
- before starting a write access to the same device or to a different external one.

The Data Float Output Time ( $t_{DF}$ ) for each external memory device is programmed in the TDF\_CYCLES field of the MODE register for the corresponding chip select. The value of TDF\_CYCLES indicates the number of data float wait cycles (between 0 and 15) before the external device releases the bus, and represents the time allowed for the data output to go to high impedance after the memory is disabled.

Data float wait states do not delay internal memory accesses. Hence, a single access to an external memory with long  $t_{DF}$  will not slow down the execution of a program from internal memory.

The data float wait states management depends on the READ\_MODE and the TDF\_MODE fields of the MODE register for the corresponding chip select.

##### 27.6.6.1 READ\_MODE

Setting the READ\_MODE to 1 indicates to the SMC that the NRD signal is responsible for turning off the tri-state buffers of the external memory device. The Data Float Period then begins after the rising edge of the NRD signal and lasts TDF\_CYCLES MCK cycles.

When the read operation is controlled by the NCS signal (READ\_MODE = 0), the TDF field gives the number of MCK cycles during which the data bus remains busy after the rising edge of NCS.

[Figure 27-21](#) illustrates the Data Float Period in NRD-controlled mode (READ\_MODE = 1), assuming a data float period of 2 cycles (TDF\_CYCLES = 2). [Figure 27-22](#) shows the read operation when controlled by NCS (READ\_MODE = 0) and the TDF\_CYCLES parameter equals 3.

Figure 27-21. TDF Period in NRD Controlled Read Access (TDF = 2)

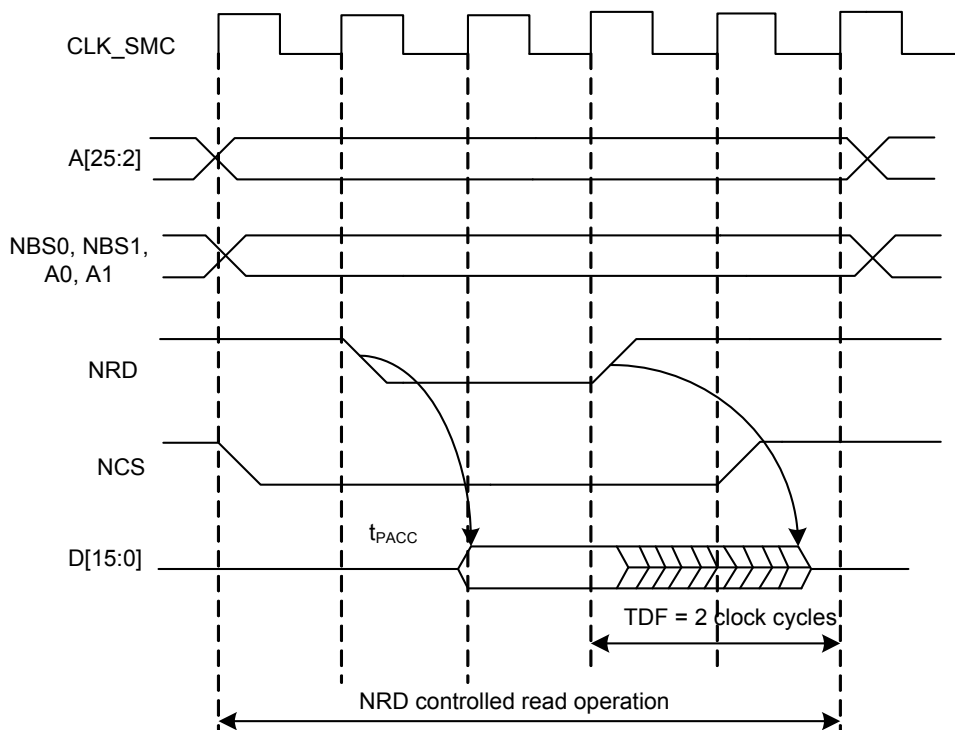
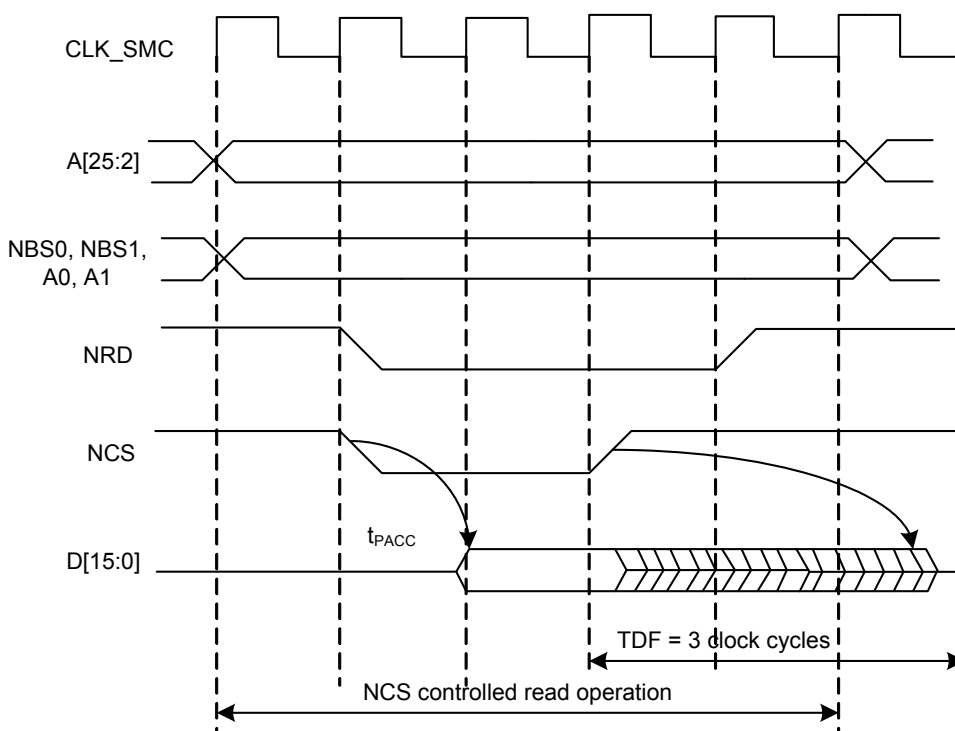

Figure 27-22. TDF Period in NCS Controlled Read Operation (TDF = 3)



## 27.6.6.2 TDF Optimization Enabled (TDF\_MODE = 1)

When the TDF\_MODE of the MODE register is set to 1 (TDF optimization is enabled), the SMC takes advantage of the setup period of the next access to optimize the number of wait states cycle to insert.

Figure 27-23 shows a read access controlled by NRD, followed by a write access controlled by NWE, on Chip Select 0. Chip Select 0 has been programmed with:

NRD\_HOLD = 4; READ\_MODE = 1 (NRD controlled)

NWE\_SETUP = 3; WRITE\_MODE = 1 (NWE controlled)

TDF\_CYCLES = 6; TDF\_MODE = 1 (optimization enabled).

**Figure 27-23.** TDF Optimization: No TDF wait states are inserted if the TDF period is over when the next access begins

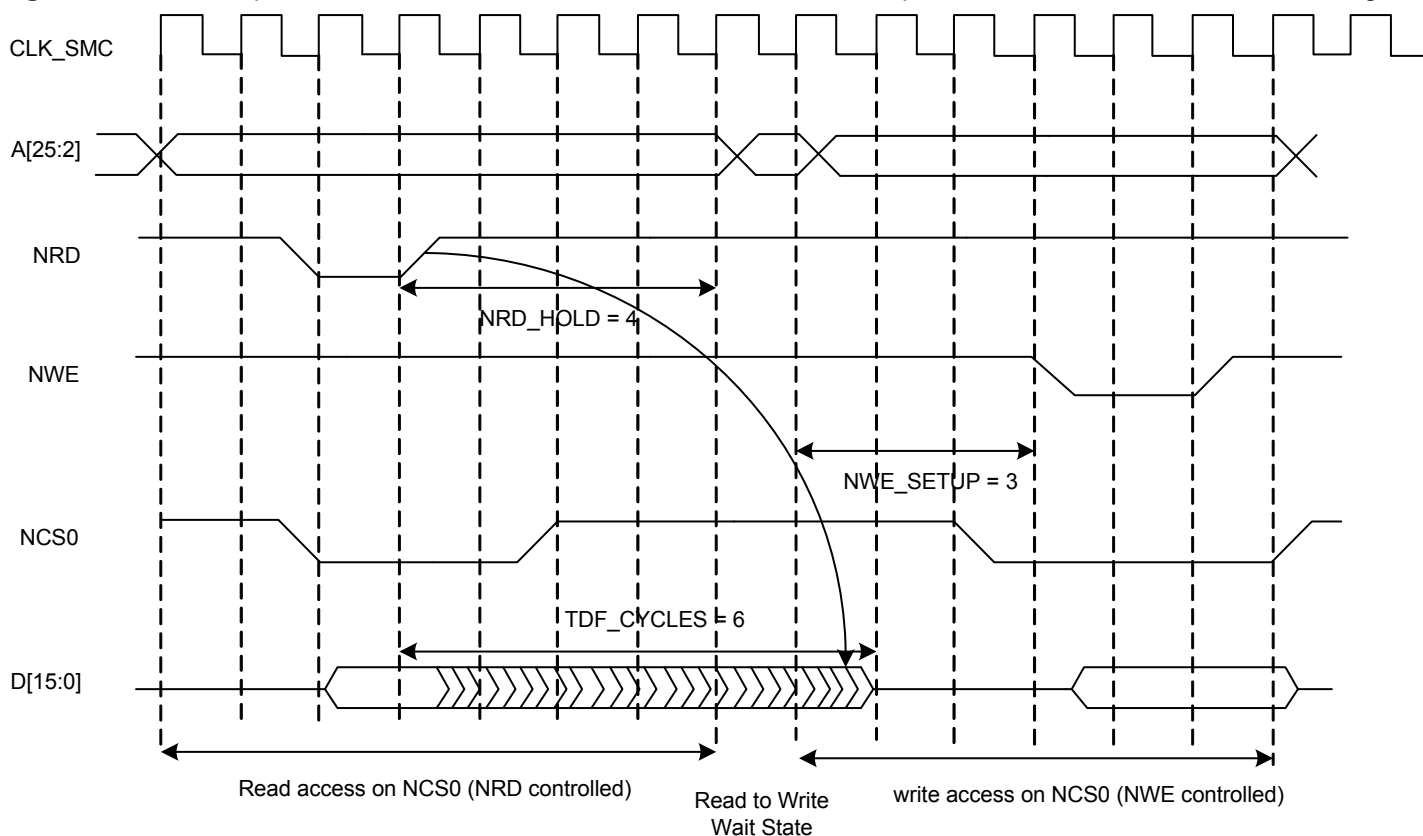

## 27.6.6.3 TDF Optimization Disabled (TDF\_MODE = 0)

When optimization is disabled, tdf wait states are inserted at the end of the read transfer, so that the data float period is ended when the second access begins. If the hold period of the read1 controlling signal overlaps the data float period, no additional tdf wait states will be inserted.

Figure 27-24, Figure 27-25 and Figure 27-26 illustrate the cases:

- read access followed by a read access on another chip select,
- read access followed by a write access on another chip select,

- read access followed by a write access on the same chip select, with no TDF optimization.

**Figure 27-24.** TDF Optimization Disabled (TDF Mode = 0). TDF wait states between 2 read accesses on different chip selects.

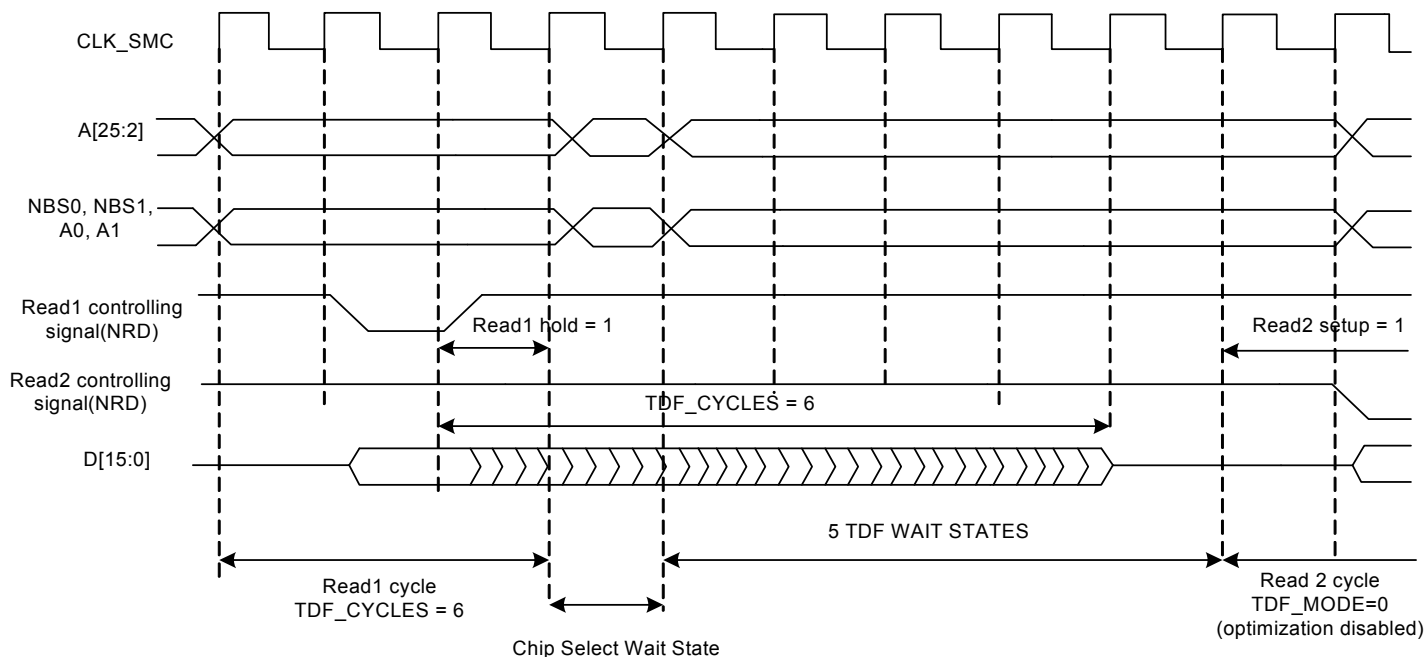

**Figure 27-25.** TDF Mode = 0: TDF wait states between a read and a write access on different chip selects.

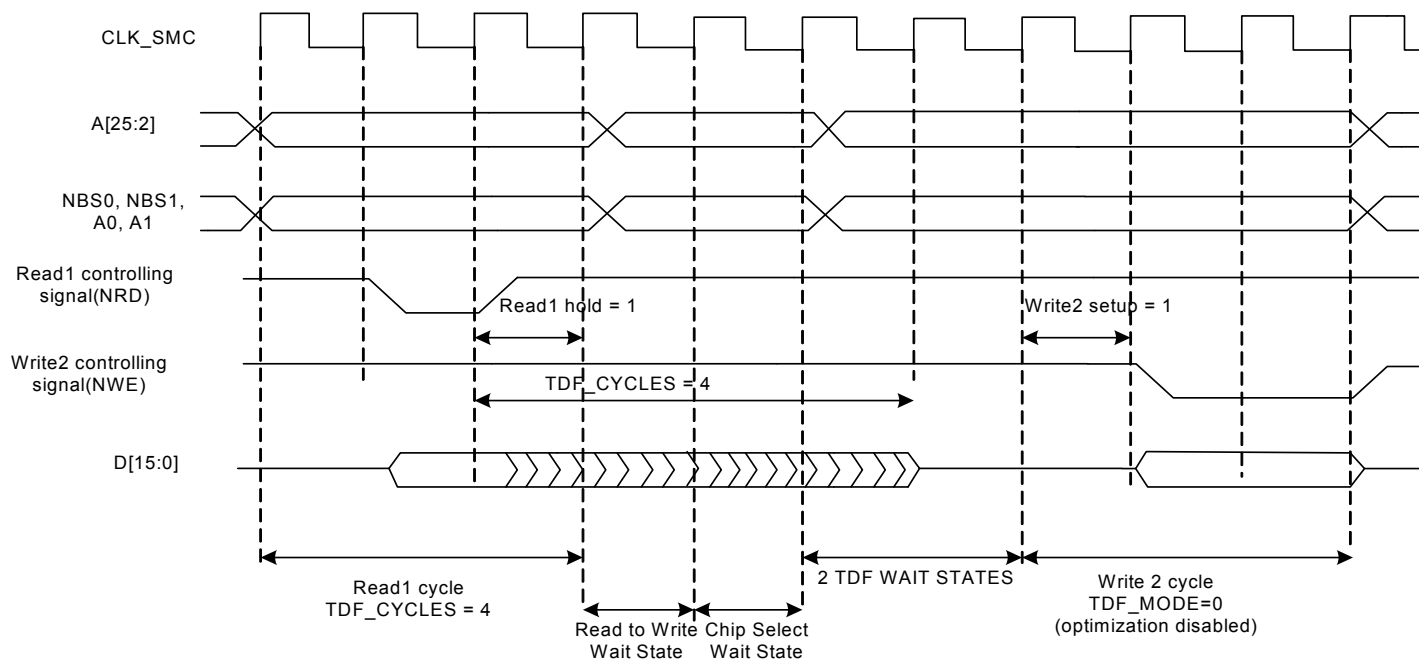

**Figure 27-26.** TDF Mode = 0: TDF wait states between read and write accesses on the same chip select.

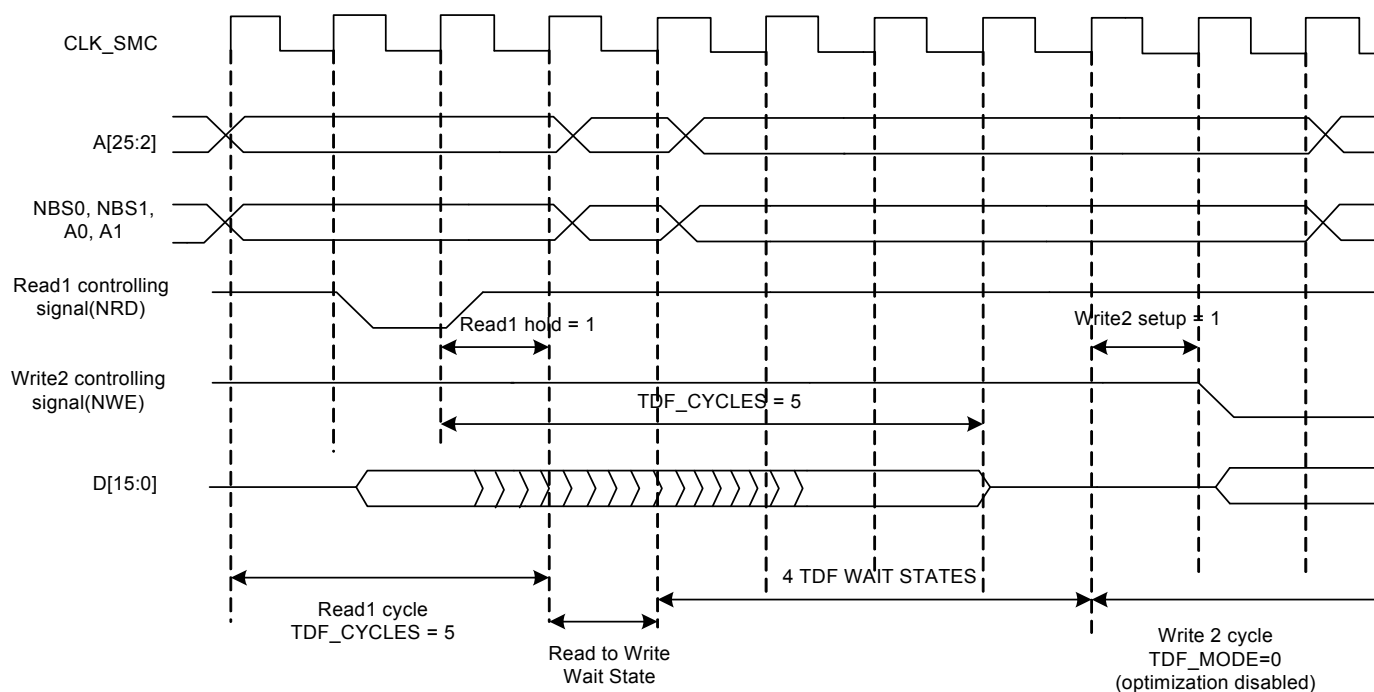

## 27.6.7 External Wait

Any access can be extended by an external device using the NWAIT input signal of the SMC. The EXNW\_MODE field of the MODE register on the corresponding chip select must be set to either to “10” (frozen mode) or “11” (ready mode). When the EXNW\_MODE is set to “00” (disabled), the NWAIT signal is simply ignored on the corresponding chip select. The NWAIT signal delays the read or write operation in regards to the read or write controlling signal, depending on the read and write modes of the corresponding chip select.

### 27.6.7.1 Restriction

When one of the EXNW\_MODE is enabled, **it is mandatory to program at least one hold cycle for the read/write controlling signal. For that reason, the NWAIT signal cannot be used in Page Mode (“Asynchronous Page Mode” on page 400), or in Slow Clock Mode (“Slow Clock Mode” on page 398).**

The NWAIT signal is assumed to be a response of the external device to the read/write request of the SMC. Then NWAIT is examined by the SMC only in the pulse state of the read or write controlling signal. The assertion of the NWAIT signal outside the expected period has no impact on SMC behavior.



## 27.6.7.2 Frozen Mode

When the external device asserts the NWAIT signal (active low), and after internal synchronization of this signal, the SMC state is frozen, i.e., SMC internal counters are frozen, and all control signals remain unchanged. When the resynchronized NWAIT signal is deasserted, the SMC completes the access, resuming the access from the point where it was stopped. See [Figure 27-27](#). This mode must be selected when the external device uses the NWAIT signal to delay the access and to freeze the SMC.

The assertion of the NWAIT signal outside the expected period is ignored as illustrated in [Figure 27-28](#).

**Figure 27-27.** Write Access with NWAIT Assertion in Frozen Mode (EXNW\_MODE = 10).

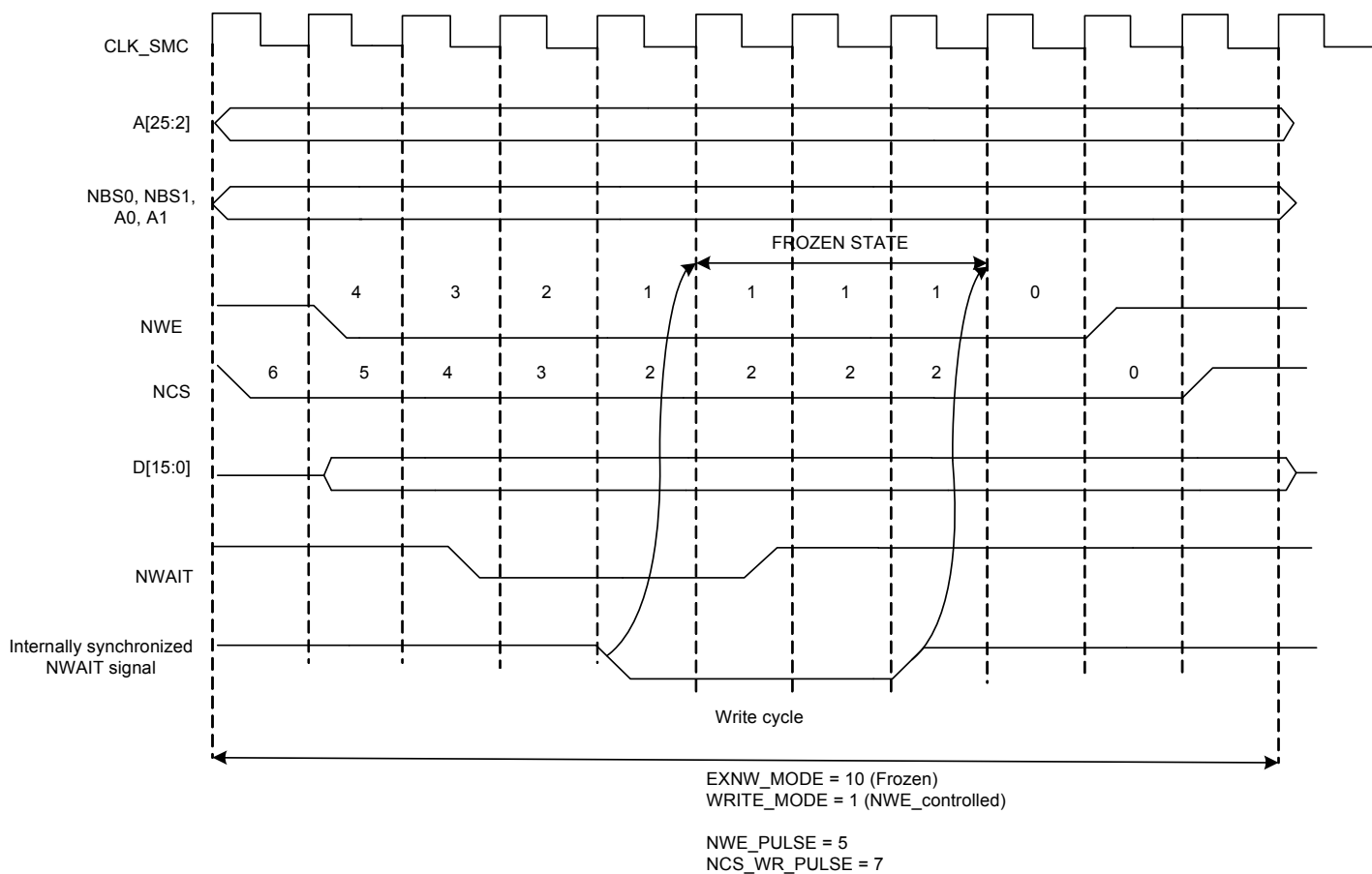
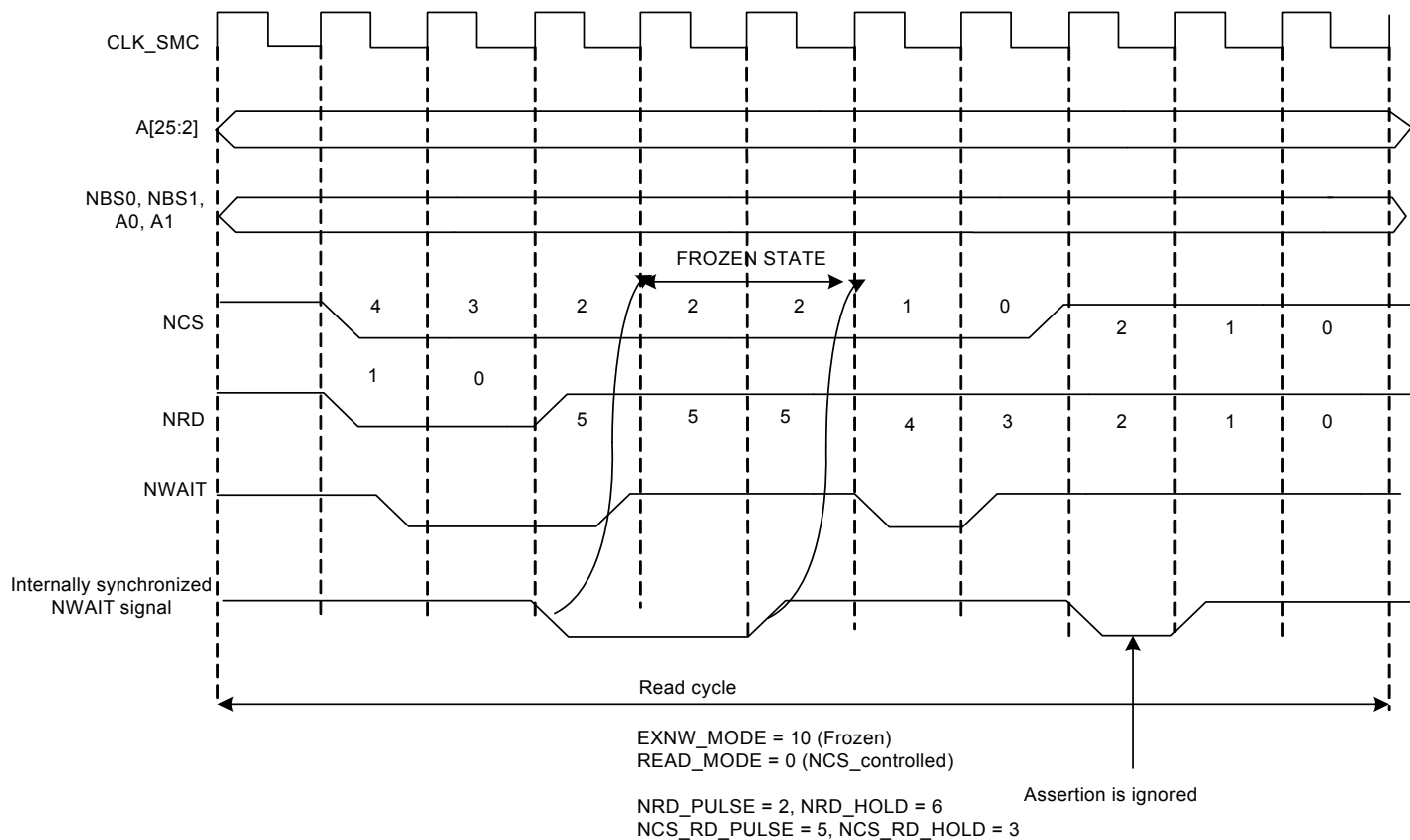

Figure 27-28. Read Access with NWAIT Assertion in Frozen Mode (EXNW\_MODE = 10).



## 27.6.7.3 Ready Mode

In Ready mode ( $EXNW\_MODE = 11$ ), the SMC behaves differently. Normally, the SMC begins the access by down counting the setup and pulse counters of the read/write controlling signal. In the last cycle of the pulse phase, the resynchronized NWAIT signal is examined.

If asserted, the SMC suspends the access as shown in [Figure 27-29](#) and [Figure 27-30](#). After deassertion, the access is completed: the hold step of the access is performed.

This mode must be selected when the external device uses deassertion of the NWAIT signal to indicate its ability to complete the read or write operation.

If the NWAIT signal is deasserted before the end of the pulse, or asserted after the end of the pulse of the controlling read/write signal, it has no impact on the access length as shown in [Figure 27-30](#).

**Figure 27-29.** NWAIT Assertion in Write Access: Ready Mode ( $EXNW\_MODE = 11$ ).

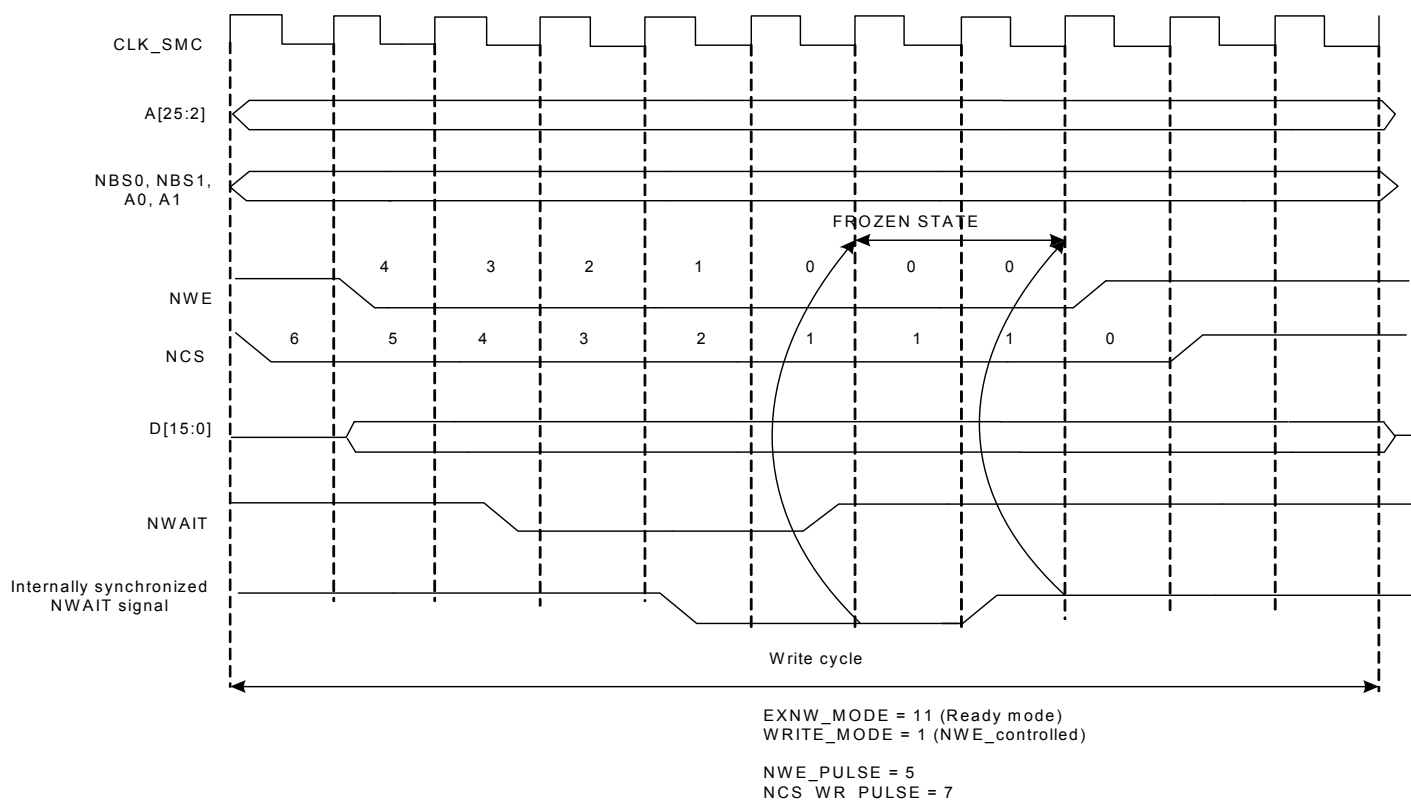
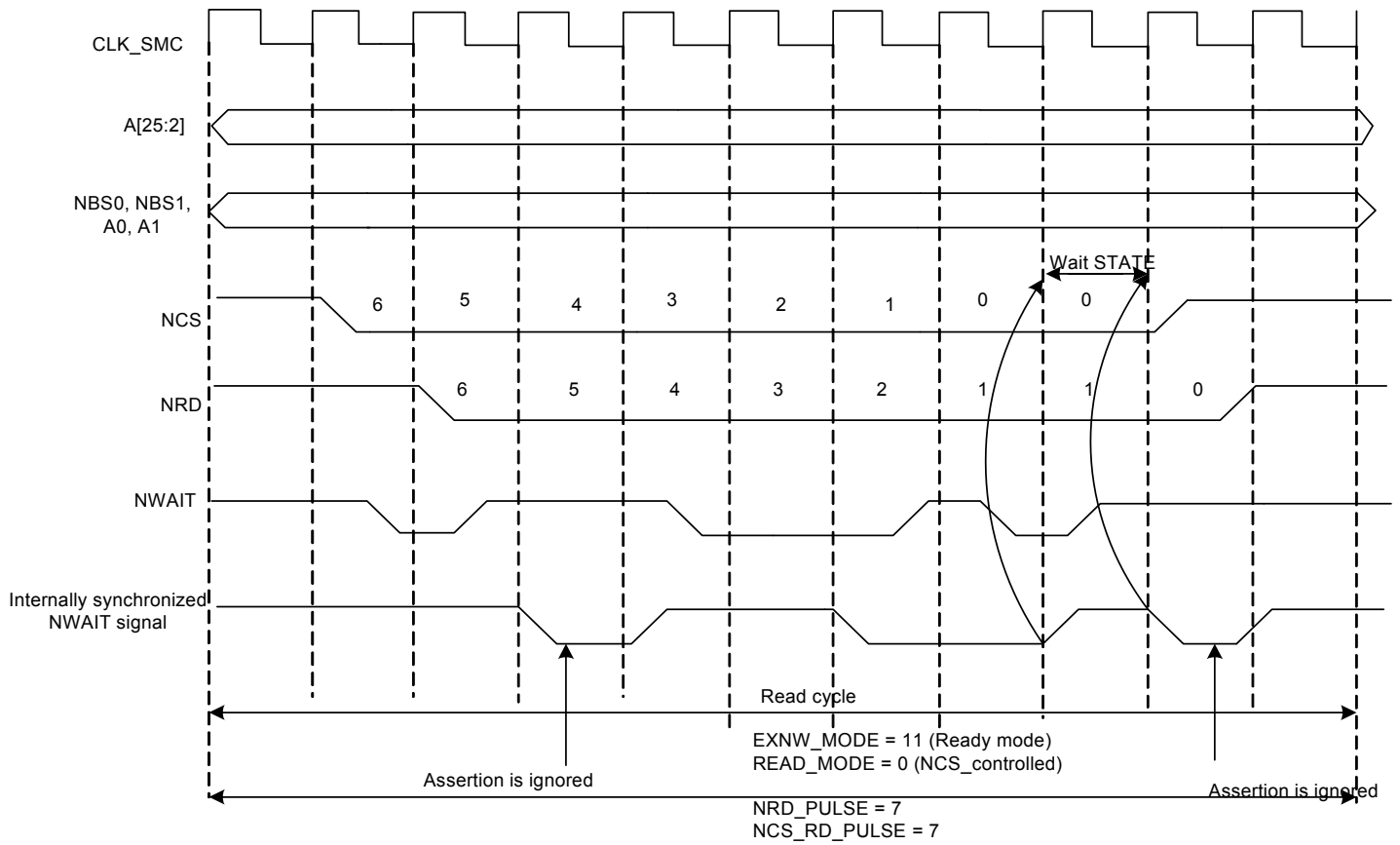

Figure 27-30. NWAIT Assertion in Read Access: Ready Mode (EXNW\_MODE = 11).





## 27.6.8 Slow Clock Mode

The SMC is able to automatically apply a set of “slow clock mode” read/write waveforms when an internal signal driven by the Power Management Controller is asserted because CLK\_SMC has been turned to a very slow clock rate (typically 32kHz clock rate). In this mode, the user-programmed waveforms are ignored and the slow clock mode waveforms are applied. This mode is provided so as to avoid reprogramming the User Interface with appropriate waveforms at very slow clock rate. When activated, the slow mode is active on all chip selects.

### 27.6.8.1 Slow Clock Mode Waveforms

Figure 27-32 illustrates the read and write operations in slow clock mode. They are valid on all chip selects. indicates the value of read and write parameters in slow clock mode.

**Figure 27-32.** Read/write Cycles in Slow Clock Mode

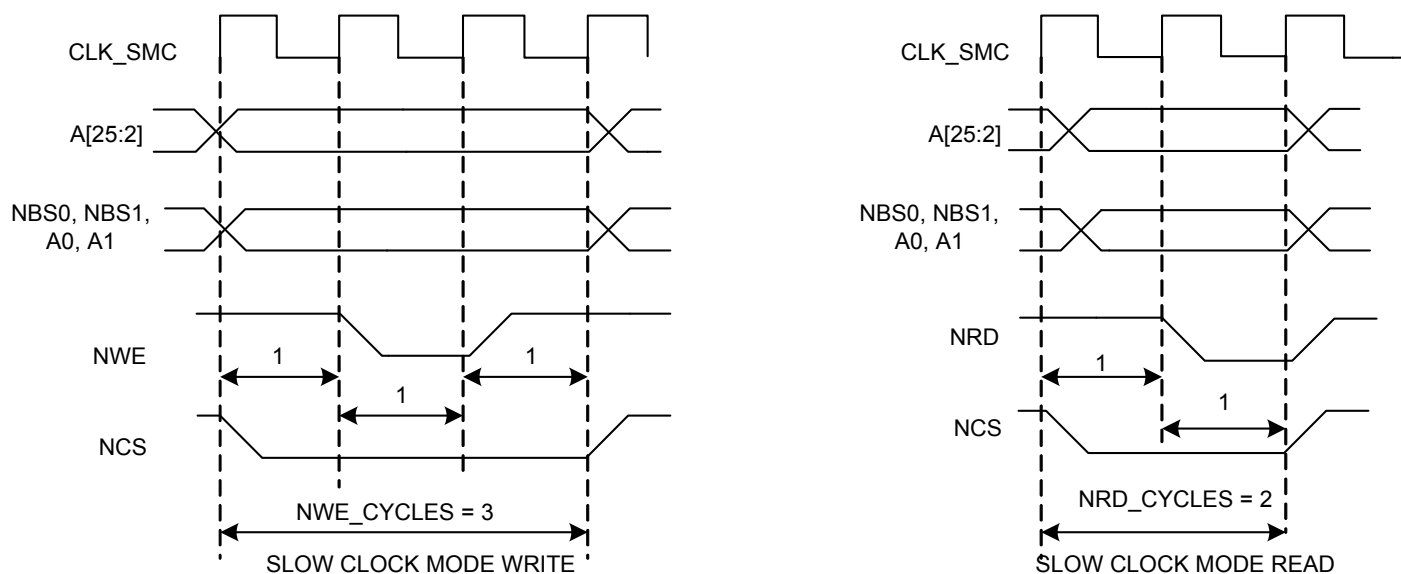

**Table 27-4.** Read and Write Timing Parameters in Slow Clock Mode

Read Parameters	Duration (cycles)	Write Parameters	Duration (cycles)
NRD_SETUP	1	NWE_SETUP	1
NRD_PULSE	1	NWE_PULSE	1
NCS_RD_SETUP	0	NCS_WR_SETUP	0
NCS_RD_PULSE	2	NCS_WR_PULSE	3
NRD_CYCLE	2	NWE_CYCLE	3

27.6.8.2 Switching from (to) Slow Clock Mode to (from) Normal Mode

When switching from slow clock mode to the normal mode, the current slow clock mode transfer is completed at high clock rate, with the set of slow clock mode parameters. See [Figure 27-33 on page 399](#). The external device may not be fast enough to support such timings.

[Figure 27-34](#) illustrates the recommended procedure to properly switch from one mode to the other.

**Figure 27-33.** Clock Rate Transition Occurs while the SMC is Performing a Write Operation

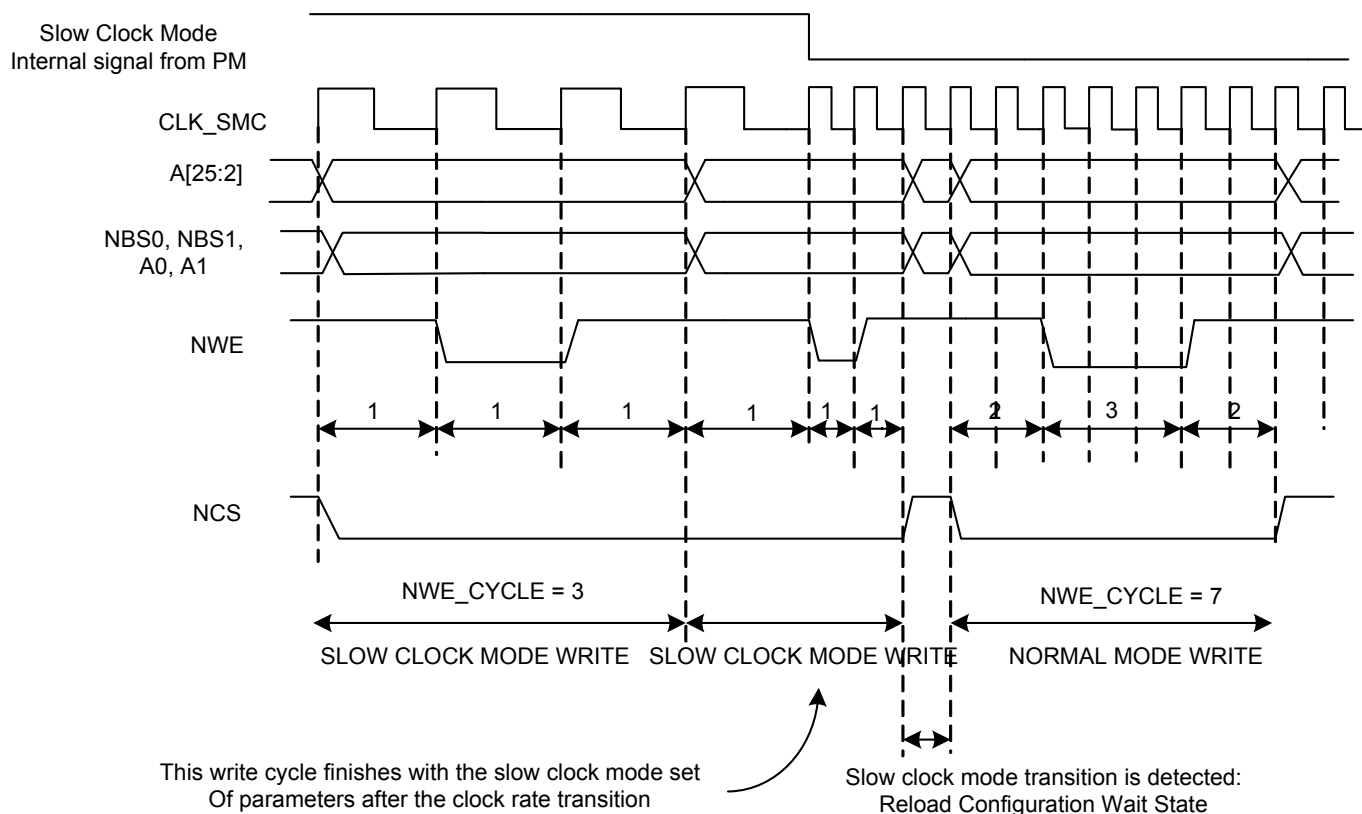

**Figure 27-34.** Recommended Procedure to Switch from Slow Clock Mode to Normal Mode or from Normal Mode to Slow Clock Mode

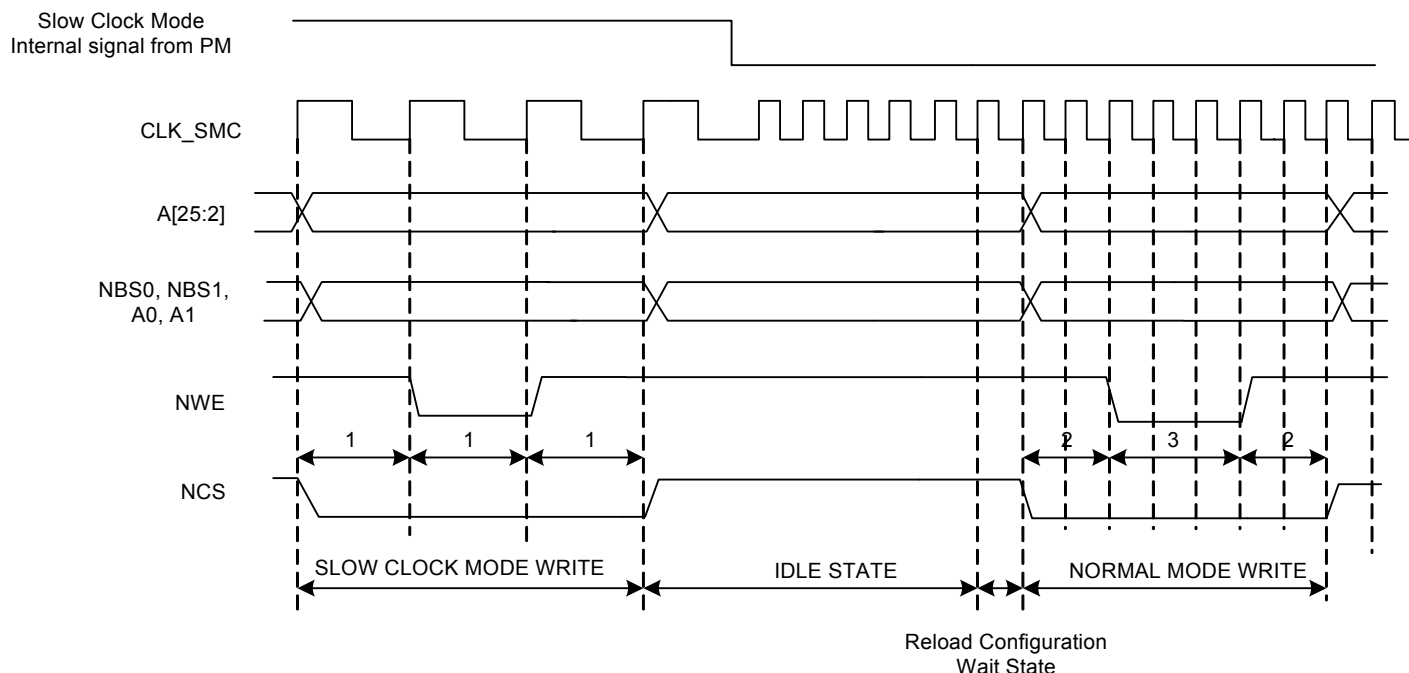

## 27.6.9 Asynchronous Page Mode

The SMC supports asynchronous burst reads in page mode, providing that the page mode is enabled in the MODE register (PMEN field). The page size must be configured in the MODE register (PS field) to 4, 8, 16 or 32 bytes.

The page defines a set of consecutive bytes into memory. A 4-byte page (resp. 8-, 16-, 32-byte page) is always aligned to 4-byte boundaries (resp. 8-, 16-, 32-byte boundaries) of memory. The MSB of data address defines the address of the page in memory, the LSB of address define the address of the data in the page as detailed in [Table 27-5](#).

With page mode memory devices, the first access to one page ( $t_{pa}$ ) takes longer than the subsequent accesses to the page ( $t_{sa}$ ) as shown in [Figure 27-35](#). When in page mode, the SMC enables the user to define different read timings for the first access within one page, and next accesses within the page.

**Table 27-5.** Page Address and Data Address within a Page

Page Size	Page Address <sup>(1)</sup>	Data Address in the Page <sup>(2)</sup>
4 bytes	A[25:2]	A[1:0]
8 bytes	A[25:3]	A[2:0]
16 bytes	A[25:4]	A[3:0]
32 bytes	A[25:5]	A[4:0]

- Notes: 1. A denotes the address bus of the memory device  
 2. For 16-bit devices, the bit 0 of address is ignored. For 32-bit devices, bits [1:0] are ignored.

### 27.6.9.1 Protocol and Timings in Page Mode

[Figure 27-35](#) shows the NRD and NCS timings in page mode access.



**Figure 27-35.** Page Mode Read Protocol (Address MSB and LSB are defined in [Table 27-5](#))

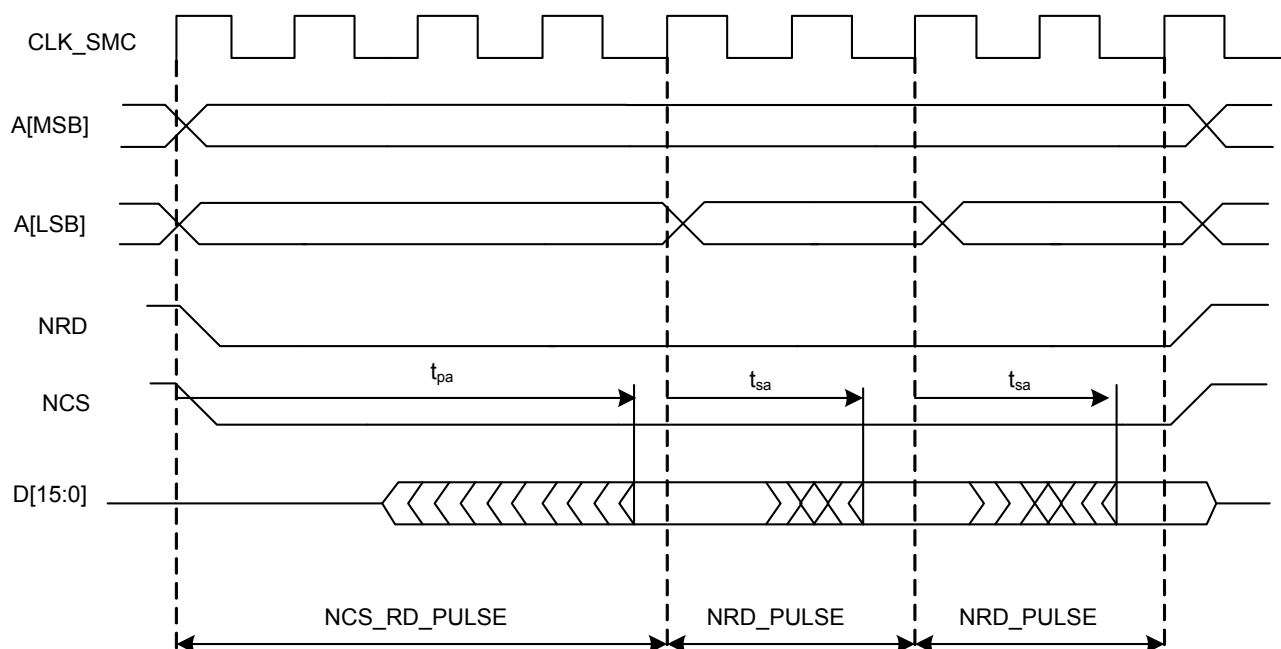

The NRD and NCS signals are held low during all read transfers, whatever the programmed values of the setup and hold timings in the User Interface may be. Moreover, the NRD and NCS timings are identical. The pulse length of the first access to the page is defined with the NCS\_RD\_PULSE field of the PULSE register. The pulse length of subsequent accesses within the page are defined using the NRD\_PULSE parameter.

In page mode, the programming of the read timings is described in [Table 27-6](#):

**Table 27-6.** Programming of Read Timings in Page Mode

Parameter	Value	Definition
READ_MODE	'x'	No impact
NCS_RD_SETUP	'x'	No impact
NCS_RD_PULSE	$t_{pa}$	Access time of first access to the page
NRD_SETUP	'x'	No impact
NRD_PULSE	$t_{sa}$	Access time of subsequent accesses in the page
NRD_CYCLE	'x'	No impact

The SMC does not check the coherency of timings. It will always apply the NCS\_RD\_PULSE timings as page access timing ( $t_{pa}$ ) and the NRD\_PULSE for accesses to the page ( $t_{sa}$ ), even if the programmed value for  $t_{pa}$  is shorter than the programmed value for  $t_{sa}$ .

### 27.6.9.2 Byte Access Type in Page Mode

The Byte Access Type configuration remains active in page mode. For 16-bit or 32-bit page mode devices that require byte selection signals, configure the BAT field of the REGISTER to 0 (byte select access type).

## 27.6.9.3 Page Mode Restriction

The page mode is not compatible with the use of the NWAIT signal. Using the page mode and the NWAIT signal may lead to unpredictable behavior.

## 27.6.9.4 Sequential and Non-sequential Accesses

If the chip select and the MSB of addresses as defined in [Table 27-5](#) are identical, then the current access lies in the same page as the previous one, and no page break occurs.

Using this information, all data within the same page, sequential or not sequential, are accessed with a minimum access time ( $t_{sa}$ ). [Figure 27-36](#) illustrates access to an 8-bit memory device in page mode, with 8-byte pages. Access to D1 causes a page access with a long access time ( $t_{pa}$ ). Accesses to D3 and D7, though they are not sequential accesses, only require a short access time ( $t_{sa}$ ).

If the MSB of addresses are different, the SMC performs the access of a new page. In the same way, if the chip select is different from the previous access, a page break occurs. If two sequential accesses are made to the page mode memory, but separated by an other internal or external peripheral access, a page break occurs on the second access because the chip select of the device was deasserted between both accesses.

**Figure 27-36.** Access to Non-sequential Data within the Same Page

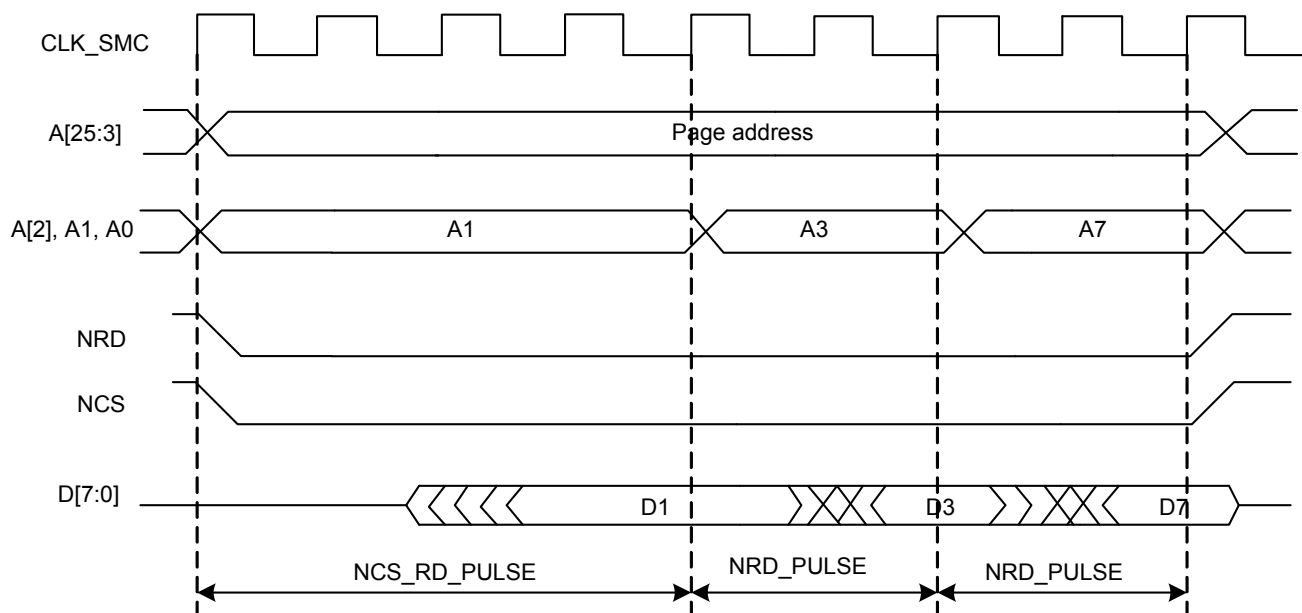

## 27.7 User Interface

The SMC is programmed using the registers listed in [Table 27-7](#). For each chip select, a set of 4 registers is used to program the parameters of the external device connected on it. In [Table 27-7](#), “CS\_number” denotes the chip select number. 16 bytes (0x10) are required per chip select.

The user must complete writing the configuration by writing any one of the MODE registers.

**Table 27-7.** SMC Register Mapping

Offset	Register	Name	Access	Reset State
0x10 x CS_number + 0x00	SMC Setup Register	SETUP	Read/Write	–
0x10 x CS_number + 0x04	SMC Pulse Register	PULSE	Read/Write	–
0x10 x CS_number + 0x08	SMC Cycle Register	CYCLE	Read/Write	–
0x10 x CS_number + 0x0C	SMC Mode Register	MODE	Read/Write	–

## 27.7.1 Setup Register

**Register Name:** SETUP[0 ..3]

**Access Type:** Read/Write

**Offset:** 0x10 x CS\_number + 0x00

**Reset Value:** –

31	30	29	28	27	26	25	24
–	–	NCS_RD_SETUP					
23	22	21	20	19	18	17	16
–	–	NRD_SETUP					
15	14	13	12	11	10	9	8
–	–	NCS_WR_SETUP					
7	6	5	4	3	2	1	0
–	–	NWE_SETUP					

- **NCS\_RD\_SETUP: NCS Setup Length in READ Access**

In read access, the NCS signal setup length is defined as:

$$\text{NCS setup length} = (128 * \text{NCS\_RD\_SETUP}[5] + \text{NCS\_RD\_SETUP}[4:0]) \text{ clock cycles}$$

- **NRD\_SETUP: NRD Setup Length**

The NRD signal setup length is defined in clock cycles as:

$$\text{NRD setup length} = (128 * \text{NRD\_SETUP}[5] + \text{NRD\_SETUP}[4:0]) \text{ clock cycles}$$

- **NCS\_WR\_SETUP: NCS Setup Length in WRITE Access**

In write access, the NCS signal setup length is defined as:

$$\text{NCS setup length} = (128 * \text{NCS\_WR\_SETUP}[5] + \text{NCS\_WR\_SETUP}[4:0]) \text{ clock cycles}$$

- **NWE\_SETUP: NWE Setup Length**

The NWE signal setup length is defined as:

$$\text{NWE setup length} = (128 * \text{NWE\_SETUP}[5] + \text{NWE\_SETUP}[4:0]) \text{ clock cycles}$$

## 27.7.2 Pulse Register

**Register Name:** PULSE[0..3]  
**Access Type:** Read/Write  
**Offset:** 0x10 x CS\_number + 0x04  
**Reset Value:** –

31	30	29	28	27	26	25	24
–	NCS_RD_PULSE						
23	22	21	20	19	18	17	16
–	NRD_PULSE						
15	14	13	12	11	10	9	8
–	NCS_WR_PULSE						
7	6	5	4	3	2	1	0
–	NWE_PULSE						

- **NCS\_RD\_PULSE: NCS Pulse Length in READ Access**

In standard read access, the NCS signal pulse length is defined as:

$$\text{NCS pulse length} = (256 * \text{NCS\_RD\_PULSE}[6] + \text{NCS\_RD\_PULSE}[5:0]) \text{ clock cycles}$$

The NCS pulse length must be at least 1 clock cycle.

In page mode read access, the NCS\_RD\_PULSE parameter defines the duration of the first access to one page.

- **NRD\_PULSE: NRD Pulse Length**

In standard read access, the NRD signal pulse length is defined in clock cycles as:

$$\text{NRD pulse length} = (256 * \text{NRD\_PULSE}[6] + \text{NRD\_PULSE}[5:0]) \text{ clock cycles}$$

The NRD pulse length must be at least 1 clock cycle.

In page mode read access, the NRD\_PULSE parameter defines the duration of the subsequent accesses in the page.

- **NCS\_WR\_PULSE: NCS Pulse Length in WRITE Access**

In write access, the NCS signal pulse length is defined as:

$$\text{NCS pulse length} = (256 * \text{NCS\_WR\_PULSE}[6] + \text{NCS\_WR\_PULSE}[5:0]) \text{ clock cycles}$$

The NCS pulse length must be at least 1 clock cycle.

- **NWE\_PULSE: NWE Pulse Length**

The NWE signal pulse length is defined as:

$$\text{NWE pulse length} = (256 * \text{NWE\_PULSE}[6] + \text{NWE\_PULSE}[5:0]) \text{ clock cycles}$$

The NWE pulse length must be at least 1 clock cycle.

## 27.7.3 Cycle Register

**Register Name:** CYCLE[0..3]

**Access Type:** Read/Write

**Offset:** 0x10 x CS\_number + 0x08

**Reset Value:** –

31	30	29	28	27	26	25	24
–	–	–	–	–	–	–	NRD_CYCLE
23	22	21	20	19	18	17	16
NRD_CYCLE							
15	14	13	12	11	10	9	8
–	–	–	–	–	–	–	NWE_CYCLE
7	6	5	4	3	2	1	0
NWE_CYCLE							

- **NRD\_CYCLE: Total Read Cycle Length**

The total read cycle length is the total duration in clock cycles of the read cycle. It is equal to the sum of the setup, pulse and hold steps of the NRD and NCS signals. It is defined as:

Read cycle length = (NRD\_CYCLE[8:7]\*256 + NRD\_CYCLE[6:0]) clock cycles

- **NWE\_CYCLE: Total Write Cycle Length**

The total write cycle length is the total duration in clock cycles of the write cycle. It is equal to the sum of the setup, pulse and hold steps of the NWE and NCS signals. It is defined as:

Write cycle length = (NWE\_CYCLE[8:7]\*256 + NWE\_CYCLE[6:0]) clock cycles

## 27.7.4 MODE Register

**Register Name:** MODE[0..3]

**Access Type:** Read/Write

**Offset:** 0x10 x CS\_number + 0x0C

**Reset Value:** –

31	30	29	28	27	26	25	24
–	–	PS		–	–	–	PMEN
23	22	21	20	19	18	17	16
–	–	–	TDF_MODE	TDF_CYCLES			
15	14	13	12	11	10	9	8
–	–	DBW		–	–	–	BAT
7	6	5	4	3	2	1	0
–	–	EXNW_MODE		–	–	WRITE_MODE	READ_MODE

- **PS: Page Size**

If page mode is enabled, this field indicates the size of the page in bytes.

**Table 27-8.** Page size settings.

PS		Page Size
0	0	4-byte page
0	1	8-byte page
1	0	16-byte page
1	1	32-byte page

- **PMEN: Page Mode Enabled**

1: Asynchronous burst read in page mode is applied on the corresponding chip select.

0: Standard read is applied.

- **TDF\_MODE: TDF Optimization**

1: TDF optimization is enabled.

– The number of TDF wait states is optimized using the setup period of the next read/write access.

0: TDF optimization is disabled.

– The number of TDF wait states is inserted before the next access begins.

- **TDF\_CYCLES: Data Float Time**

This field gives the integer number of clock cycles required by the external device to release the data after the rising edge of the read controlling signal. The SMC always provide one full cycle of bus turnaround after the TDF\_CYCLES period. The

external bus cannot be used by another chip select during TDF\_CYCLES + 1 cycles. From 0 up to 15 TDF\_CYCLES can be set.

• **Data Bus Width (DBW)**

DBW		Data Bus Width
0	0	8-bit bus
0	1	16-bit bus
1	0	32-bit bus
1	1	Reserved

• **BAT: Byte Access Type**

This field is used only if DBW defines a 16- or 32-bit data bus.

1: Byte write access type:

- Write operation is controlled using NCS, NWR0, NWR1, NWR2, NWR3.
- Read operation is controlled using NCS and NRD.

0: Byte select access type:

- Write operation is controlled using NCS, NWE, NBS0, NBS1, NBS2 and NBS3
- Read operation is controlled using NCS, NRD, NBS0, NBS1, NBS2 and NBS3

• **EXNW\_MODE: NWAIT Mode**

The NWAIT signal is used to extend the current read or write signal. It is only taken into account during the pulse phase of the read and write controlling signal. When the use of NWAIT is enabled, at least one cycle hold duration must be programmed for the read and write controlling signal.

**Table 27-9.** EXNW\_MODE

EXNW_MODE		NWAIT Mode
0	0	Disabled
0	1	Reserved
1	0	Frozen Mode
1	1	Ready Mode

- **Disabled Mode:** The NWAIT input signal is ignored on the corresponding Chip Select.
- **Frozen Mode:** If asserted, the NWAIT signal freezes the current read or write cycle. After deassertion, the read/write cycle is resumed from the point where it was stopped.
- **Ready Mode:** The NWAIT signal indicates the availability of the external device at the end of the pulse of the controlling read or write signal, to complete the access. If high, the access normally completes. If low, the access is extended until NWAIT returns high.

• **WRITE\_MODE**

1: The write operation is controlled by the NWE signal.

- If TDF optimization is enabled (TDF\_MODE =1), TDF wait states will be inserted after the setup of NWE.

0: The write operation is controlled by the NCS signal.

- If TDF optimization is enabled (TDF\_MODE =1), TDF wait states will be inserted after the setup of NCS.

• **READ\_MODE:**

1: The read operation is controlled by the NRD signal.



- If TDF cycles are programmed, the external bus is marked busy after the rising edge of NRD.
- If TDF optimization is enabled (TDF\_MODE =1), TDF wait states are inserted after the setup of NRD.

0: The read operation is controlled by the NCS signal.

- If TDF cycles are programmed, the external bus is marked busy after the rising edge of NCS.
- If TDF optimization is enabled (TDF\_MODE =1), TDF wait states are inserted after the setup of NCS.

## 28. SDRAM Controller (SDRAMC)

Rev: 2.0.1.1

### 28.1 Features

- **Numerous Configurations Supported**
  - 2K, 4K, 8K Row Address Memory Parts
  - SDRAM with Two or Four Internal Banks
  - SDRAM with 16- or 32-bit Data Path
- **Programming Facilities**
  - Word, Half-word, Byte Access
  - Automatic Page Break When Memory Boundary Has Been Reached
  - Multibank Ping-pong Access
  - Timing Parameters Specified by Software
  - Automatic Refresh Operation, Refresh Rate is Programmable
  - Automatic Update of DS, TCR and PASR Parameters (Mobile SDRAM Devices)
- **Energy-saving Capabilities**
  - Self-refresh, Power-down and Deep Power Modes Supported
  - Supports Mobile SDRAM Devices
- **Error Detection**
  - Refresh Error Interrupt
- **SDRAM Power-up Initialization by Software**
- **CAS Latency of 1, 2, 3 Supported**
- **Auto Precharge Command Not Used**

### 28.2 Description

The SDRAM Controller (SDRAMC) extends the memory capabilities of a chip by providing the interface to an external 16-bit or 32-bit SDRAM device. The page size supports ranges from 2048 to 8192 and the number of columns from 256 to 2048. It supports byte (8-bit), half-word (16-bit) and word (32-bit) accesses.

The SDRAM Controller supports a read or write burst length of one location. It keeps track of the active row in each bank, thus maximizing SDRAM performance, e.g., the application may be placed in one bank and data in the other banks. So as to optimize performance, it is advisable to avoid accessing different rows in the same bank.

The SDRAM controller supports a CAS latency of 1, 2 or 3 and optimizes the read access depending on the frequency.

The different modes available - self-refresh, power-down and deep power-down modes - minimize power consumption on the SDRAM device.

### 28.3 Block Diagram

Figure 28-1. SDRAM Controller Block Diagram

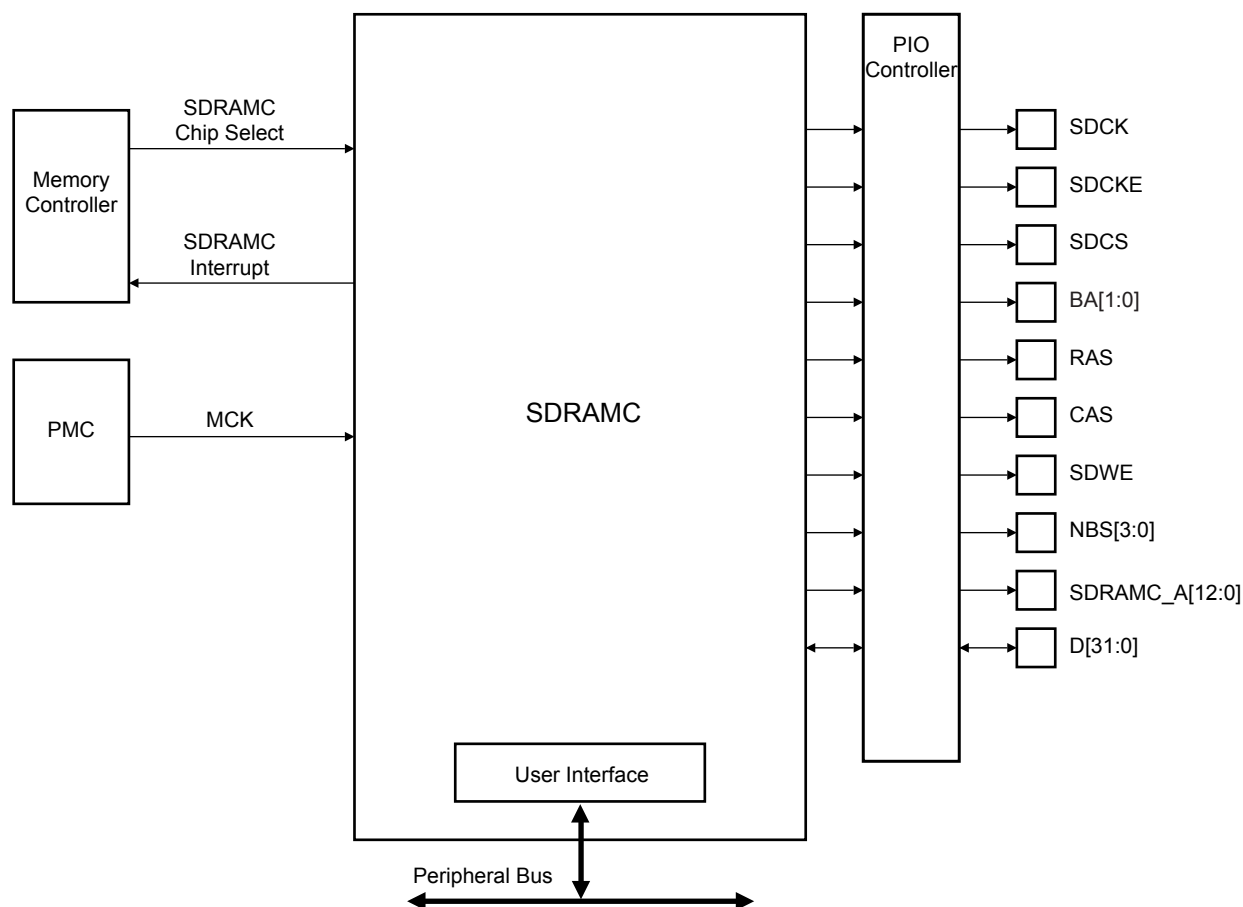

### 28.4 I/O Lines Description

Table 28-1. I/O Line Description

Name	Description	Type	Active Level
SDCK	SDRAM Clock	Output	
SDCKE	SDRAM Clock Enable	Output	High
SDCS	SDRAM Controller Chip Select	Output	Low
BA[1:0]	Bank Select Signals	Output	
RAS	Row Signal	Output	Low
CAS	Column Signal	Output	Low
SDWE	SDRAM Write Enable	Output	Low
NBS[3:0]	Data Mask Enable Signals	Output	Low
SDRAMC_A[12:0]	Address Bus	Output	
D[31:0]	Data Bus	I/O	

## 28.5 Application Example

### 28.5.1 Hardware Interface

Figure 28-2 shows an example of SDRAM device connection to the SDRAM Controller using a 32-bit data bus width. Figure 28-3 shows an example of SDRAM device connection using a 16-bit data bus width. It is important to note that these examples are given for a direct connection of the devices to the SDRAM Controller, without External Bus Interface or PIO Controller multiplexing.

Figure 28-2. SDRAM Controller Connections to SDRAM Devices: 32-bit Data Bus Width

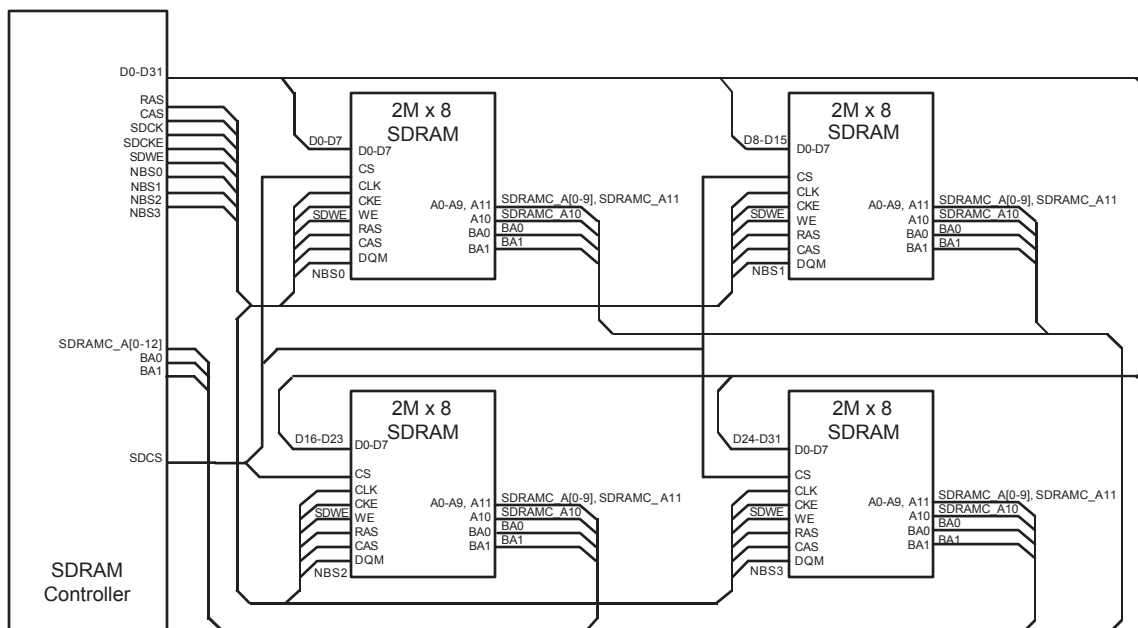
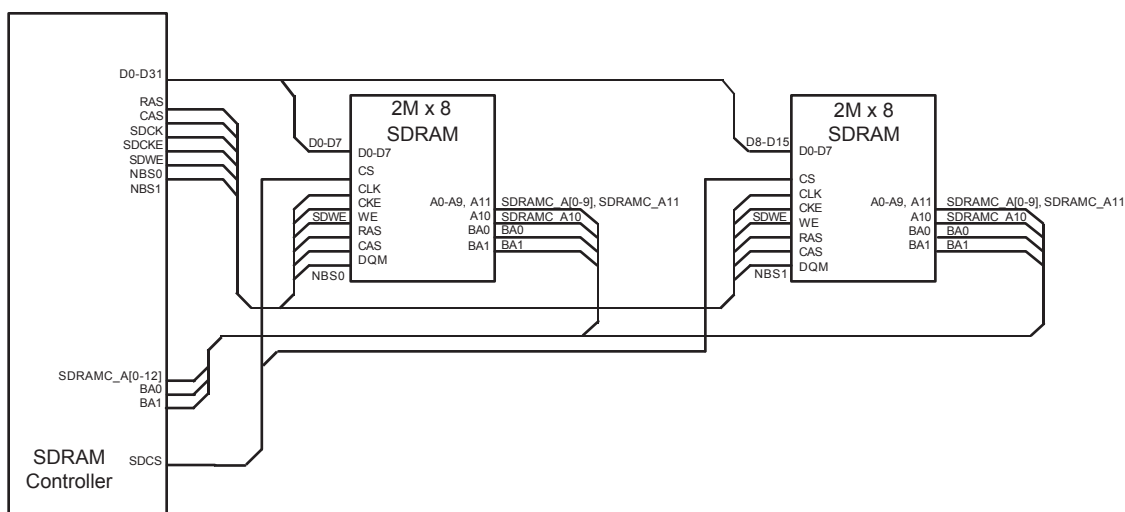

Figure 28-3. SDRAM Controller Connections to SDRAM Devices: 16-bit Data Bus Width



## 28.5.2 Software Interface

The SDRAM address space is organized into banks, rows, and columns. The SDRAM controller allows mapping different memory types according to the values set in the SDRAMC configuration register.

The SDRAM Controller's function is to make the SDRAM device access protocol transparent to the user. [Table 28-2](#) to [Table 28-7](#) illustrate the SDRAM device memory mapping seen by the user in correlation with the device structure. Various configurations are illustrated.

### 28.5.2.1 32-bit Memory Data Bus Width

**Table 28-2.** SDRAM Configuration Mapping: 2K Rows, 256/512/1024/2048 Columns

CPU Address Line																												
2	2	2	2	2	2	2	2	1	1	1	1	1	1	1	1	1	1	0	9	8	7	6	5	4	3	2	1	0
				Bk[1:0]				Row[10:0]										Column[7:0]							M[1:0]			
				Bk[1:0]				Row[10:0]										Column[8:0]							M[1:0]			
				Bk[1:0]				Row[10:0]										Column[9:0]							M[1:0]			
Bk[1:0]				Row[10:0]										Column[10:0]							M[1:0]							

**Table 28-3.** SDRAM Configuration Mapping: 4K Rows, 256/512/1024/2048 Columns

CPU Address Line																												
2	2	2	2	2	2	2	2	1	1	1	1	1	1	1	1	1	1	0	9	8	7	6	5	4	3	2	1	0
				Bk[1:0]				Row[11:0]										Column[7:0]							M[1:0]			
				Bk[1:0]				Row[11:0]										Column[8:0]							M[1:0]			
				Bk[1:0]				Row[11:0]										Column[9:0]							M[1:0]			
Bk[1:0]				Row[11:0]										Column[10:0]							M[1:0]							

**Table 28-4.** SDRAM Configuration Mapping: 8K Rows, 256/512/1024/2048 Columns

CPU Address Line																												
2	2	2	2	2	2	2	2	1	1	1	1	1	1	1	1	1	1	0	9	8	7	6	5	4	3	2	1	0
				Bk[1:0]				Row[12:0]										Column[7:0]							M[1:0]			
				Bk[1:0]				Row[12:0]										Column[8:0]							M[1:0]			
				Bk[1:0]				Row[12:0]										Column[9:0]							M[1:0]			
Bk[1:0]				Row[12:0]										Column[10:0]							M[1:0]							

- Notes:
1. M[1:0] is the byte address inside a 32-bit word.
  2. Bk[1] = BA1, Bk[0] = BA0.

## 28.5.2.2 16-bit Memory Data Bus Width

**Table 28-5.** SDRAM Configuration Mapping: 2K Rows, 256/512/1024/2048 Columns

CPU Address Line																											
27	26	25	24	23	22	21	20	19	18	17	16	15	14	13	12	11	10	9	8	7	6	5	4	3	2	1	0
						Bk[1:0]		Row[10:0]										Column[7:0]							M	0	
						Bk[1:0]		Row[10:0]										Column[8:0]							M	0	
					Bk[1:0]		Row[10:0]										Column[9:0]							M	0		
			Bk[1:0]		Row[10:0]										Column[10:0]							M	0				

**Table 28-6.** SDRAM Configuration Mapping: 4K Rows, 256/512/1024/2048 Columns

CPU Address Line																											
27	26	25	24	23	22	21	20	19	18	17	16	15	14	13	12	11	10	9	8	7	6	5	4	3	2	1	0
						Bk[1:0]		Row[11:0]										Column[7:0]							M	0	
				Bk[1:0]		Row[11:0]										Column[8:0]							M	0			
			Bk[1:0]		Row[11:0]										Column[9:0]							M	0				
		Bk[1:0]		Row[11:0]										Column[10:0]							M	0					

**Table 28-7.** SDRAM Configuration Mapping: 8K Rows, 256/512/1024/2048 Columns

CPU Address Line																											
27	26	25	24	23	22	21	20	19	18	17	16	15	14	13	12	11	10	9	8	7	6	5	4	3	2	1	0
						Bk[1:0]		Row[12:0]										Column[7:0]							M	0	
			Bk[1:0]		Row[12:0]										Column[8:0]							M	0				
		Bk[1:0]		Row[12:0]										Column[9:0]							M	0					
	Bk[1:0]		Row[12:0]										Column[10:0]							M	0						

- Notes:
1. M0 is the byte address inside a 16-bit half-word.
  2. Bk[1] = BA1, Bk[0] = BA0.

## 28.6 Product Dependencies

### 28.6.1 SDRAM Device Initialization

The initialization sequence is generated by software. The SDRAM devices are initialized by the following sequence:

1. SDRAM features must be set in the configuration register: asynchronous timings (TRC, TRAS, ...), number of column, rows, CAS latency, and the data bus width.
2. For mobile SDRAM, temperature-compensated self refresh (TCSR), drive strength (DS) and partial array self refresh (PASR) must be set in the Low Power Register.
3. The SDRAM memory type must be set in the Memory Device Register.
4. An No Operation (NOP) command must be issued to the SDRAM devices to start the SDRAM clock. The application must set Mode to 1 in the and perform a write access to any SDRAM address.
5. A minimum pause of 200  $\mu$ s is provided to precede any signal toggle.
6. An All Banks Precharge command must be issued to the SDRAM devices. The application must set Mode to 2 in the Mode Register and perform a write access to any SDRAM address.
7. Eight auto-refresh (CBR) cycles are provided. The application must set the Mode to 4 in the Mode Register and performs a write access to any SDRAM location eight times.
8. A Mode Register set (MRS) cycle must be issued to program the parameters of the SDRAM devices, in particular CAS latency and burst length. The application must set Mode to 3 in the Mode Register and perform a write access to the SDRAM. The write address must be chosen so that BA[1:0] are set to 0. For example, with a 16-bit 128 MB SDRAM (12 rows, 9 columns, 4 banks) bank address, the SDRAM write access should be done at the address 0x20000000.
9. For mobile SDRAM initialization, an Extended Mode Register set (EMRS) cycle must be issued to program the SDRAM parameters (TCSR, PASR, DS). The application must set Mode to 5 in the Mode Register and perform a write access to the SDRAM. The write address must be chosen so that BA[1] or BA[0] are set to 1. For example, with a 16-bit 128 MB SDRAM, (12 rows, 9 columns, 4 banks) bank address the SDRAM write access should be done at the address 0x20800000 or 0x20400000.
10. The application must go into Normal Mode, setting Mode to 0 in the Mode Register and performing a write access at any location in the SDRAM.
11. Write the refresh rate into the count field in the SDRAMC Refresh Timer register. (Refresh rate = delay between refresh cycles). The SDRAM device requires a refresh every 15.625  $\mu$ s or 7.81  $\mu$ s. With a 100 MHz frequency, the Refresh Timer Counter Register must be set with the value 1562 (15.625  $\mu$ s x 100 MHz) or 781 (7.81  $\mu$ s x 100 MHz).

After initialization, the SDRAM devices are fully functional.

Figure 28-4. SDRAM Device Initialization Sequence

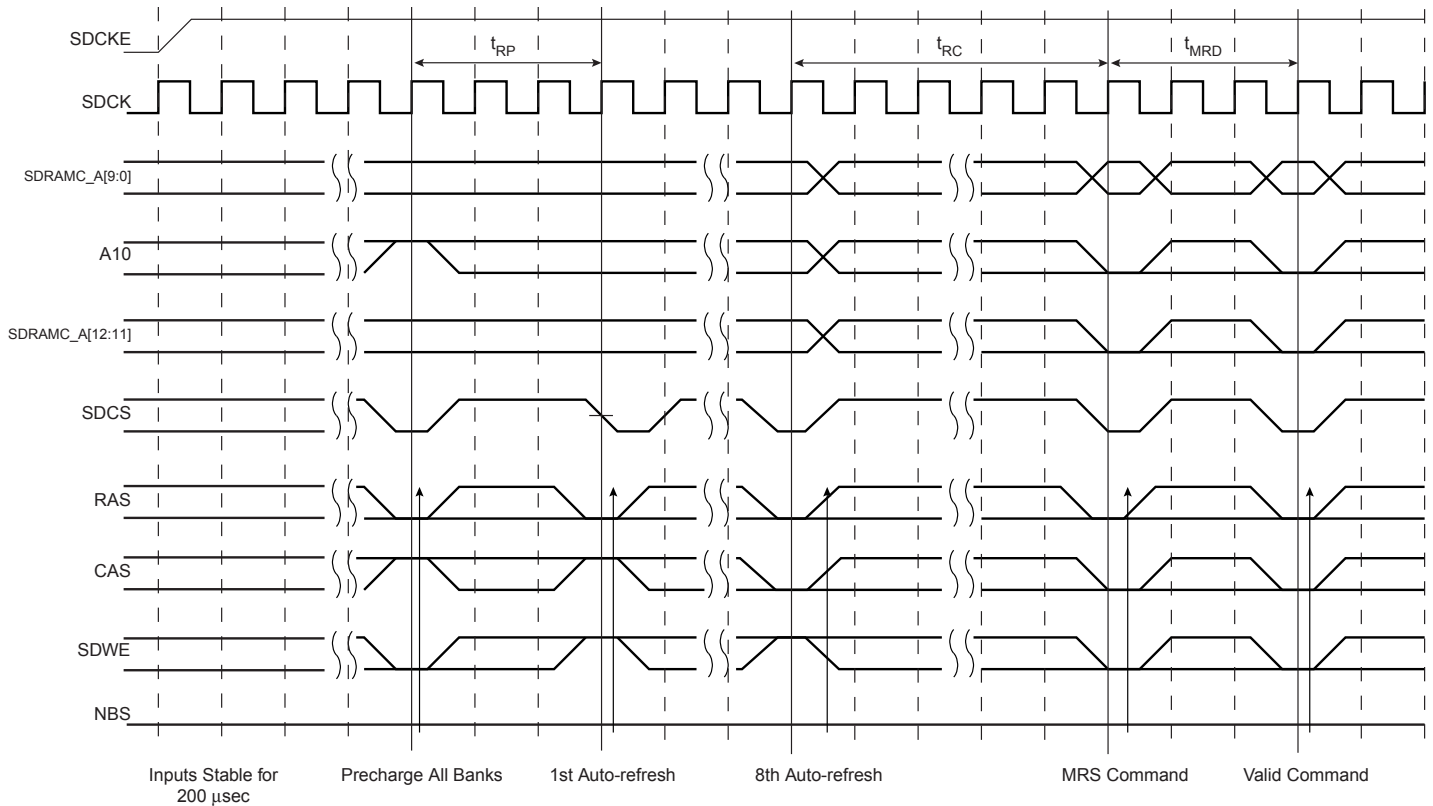

### 28.6.2 I/O Lines

The pins used for interfacing the SDRAM Controller may be multiplexed with the PIO lines. The programmer must first program the PIO controller to assign the SDRAM Controller pins to their peripheral function. If I/O lines of the SDRAM Controller are not used by the application, they can be used for other purposes by the PIO Controller.

### 28.6.3 Interrupt

The SDRAM Controller has an interrupt line connected to the interrupt controller. In order to handle interrupts, the interrupt controller must be programmed before configuring the SDRAM Controller.

Using the SDRAM Controller interrupt requires the IC to be programmed first.)



## 28.7 Functional Description

### 28.7.1 SDRAM Controller Write Cycle

The SDRAM Controller allows burst access or single access. In both cases, the SDRAM controller keeps track of the active row in each bank, thus maximizing performance. To initiate a burst access, the SDRAM Controller uses the transfer type signal provided by the master requesting the access. If the next access is a sequential write access, writing to the SDRAM device is carried out. If the next access is a write-sequential access, but the current access is to a boundary page, or if the next access is in another row, then the SDRAM Controller generates a precharge command, activates the new row and initiates a write command. To comply with SDRAM timing parameters, additional clock cycles are inserted between precharge/active ( $t_{RP}$ ) commands and active/write ( $t_{RCD}$ ) commands. For definition of these timing parameters, refer to the "SDRAMC Configuration Register" on page 427. This is described in Figure 28-5 below.

Figure 28-5. Write Burst, 32-bit SDRAM Access

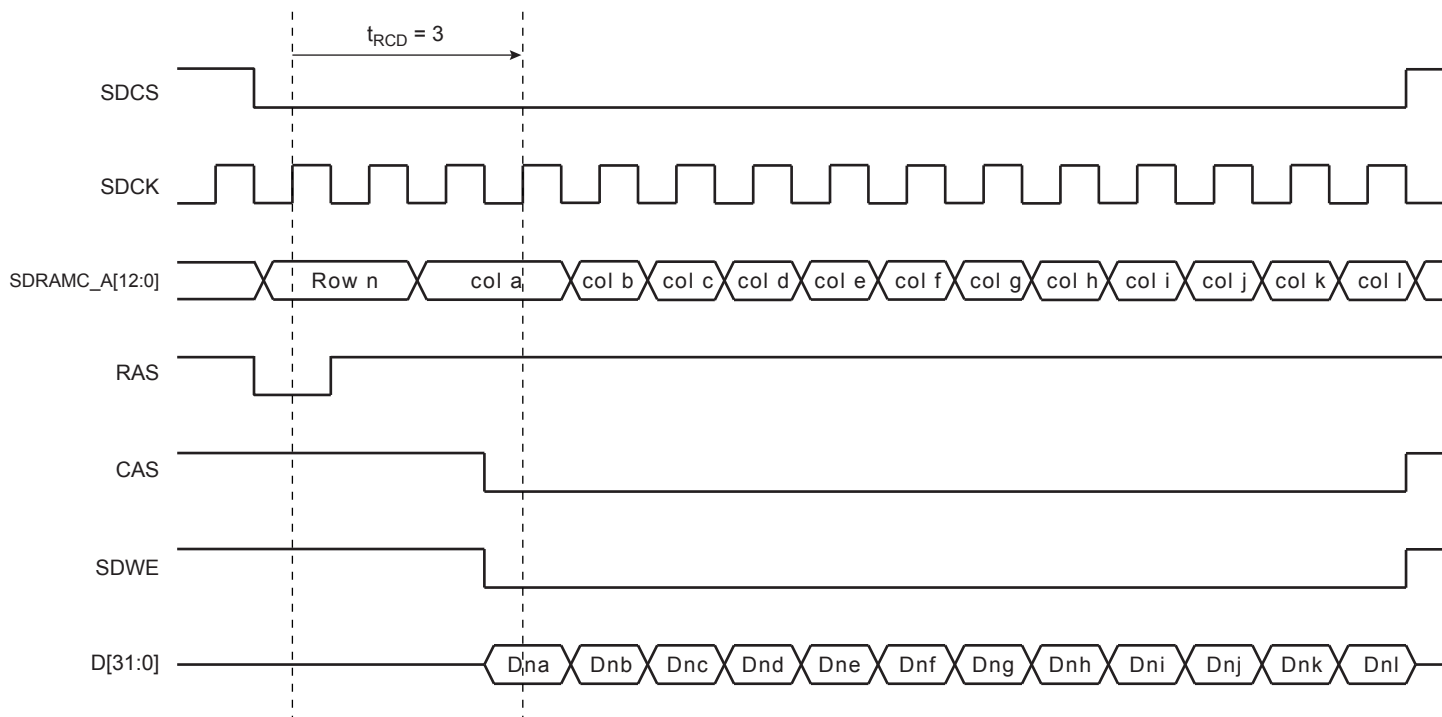

### 28.7.2 SDRAM Controller Read Cycle

The SDRAM Controller allows burst access, incremental burst of unspecified length or single access. In all cases, the SDRAM Controller keeps track of the active row in each bank, thus maximizing performance of the SDRAM. If row and bank addresses do not match the previous row/bank address, then the SDRAM controller automatically generates a precharge command, activates the new row and starts the read command. To comply with the SDRAM timing parameters, additional clock cycles on SDCK are inserted between precharge and active commands ( $t_{RP}$ ) and between active and read command ( $t_{RCD}$ ). These two parameters are set in the configuration register of the SDRAM Controller. After a read command, additional wait states are generated to comply with the CAS latency (1, 2 or 3 clock delays specified in the configuration register).

For a single access or an incremented burst of unspecified length, the SDRAM Controller anticipates the next access. While the last value of the column is returned by the SDRAM Controller on the bus, the SDRAM Controller anticipates the read to the next column and thus anticipates the CAS latency. This reduces the effect of the CAS latency on the internal bus.

For burst access of specified length (4, 8, 16 words), access is not anticipated. This case leads to the best performance. If the burst is broken (border, busy mode, etc.), the next access is handled as an incrementing burst of unspecified length.

**Figure 28-6.** Read Burst, 32-bit SDRAM Access

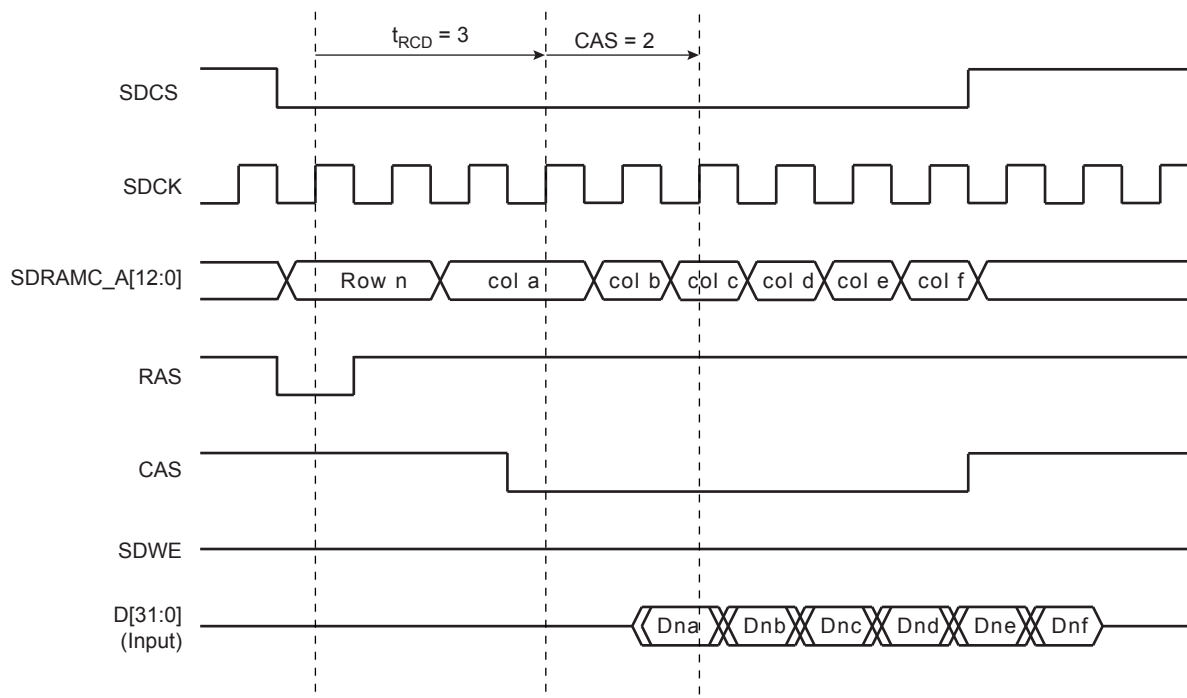

### 28.7.3 Border Management

When the memory row boundary has been reached, an automatic page break is inserted. In this case, the SDRAM controller generates a precharge command, activates the new row and initiates a read or write command. To comply with SDRAM timing parameters, an additional clock cycle is inserted between the precharge/active ( $t_{RP}$ ) command and the active/read ( $t_{RCD}$ ) command. This is described in [Figure 28-7](#) below.

Figure 28-7. Read Burst with Boundary Row Access

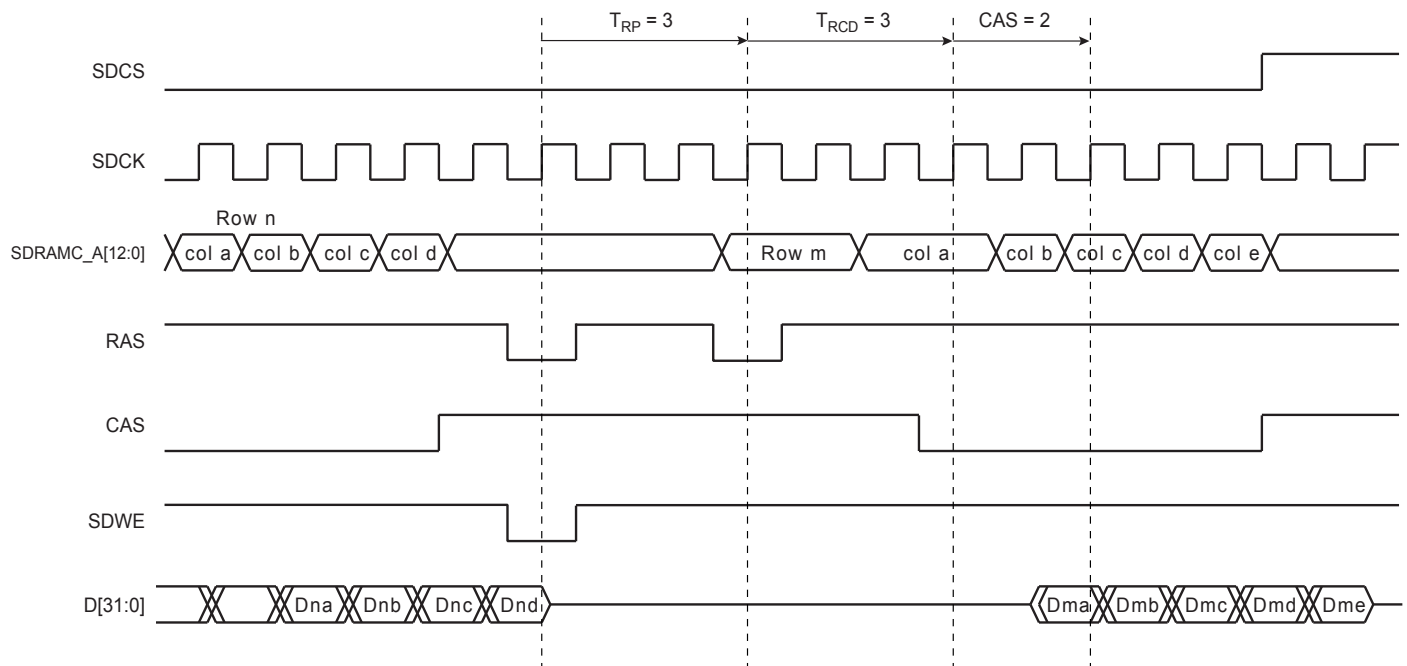

#### 28.7.4 SDRAM Controller Refresh Cycles

An auto-refresh command is used to refresh the SDRAM device. Refresh addresses are generated internally by the SDRAM device and incremented after each auto-refresh automatically. The SDRAM Controller generates these auto-refresh commands periodically. An internal timer is loaded with the value in the register TR that indicates the number of clock cycles between refresh cycles.

A refresh error interrupt is generated when the previous auto-refresh command did not perform. It is acknowledged by reading the Interrupt Status Register (ISR).

When the SDRAM Controller initiates a refresh of the SDRAM device, internal memory accesses are not delayed. However, if the CPU tries to access the SDRAM, the slave indicates that the device is busy and the master is held by a wait signal. See [Figure 28-8](#).

**Figure 28-8.** Refresh Cycle Followed by a Read Access

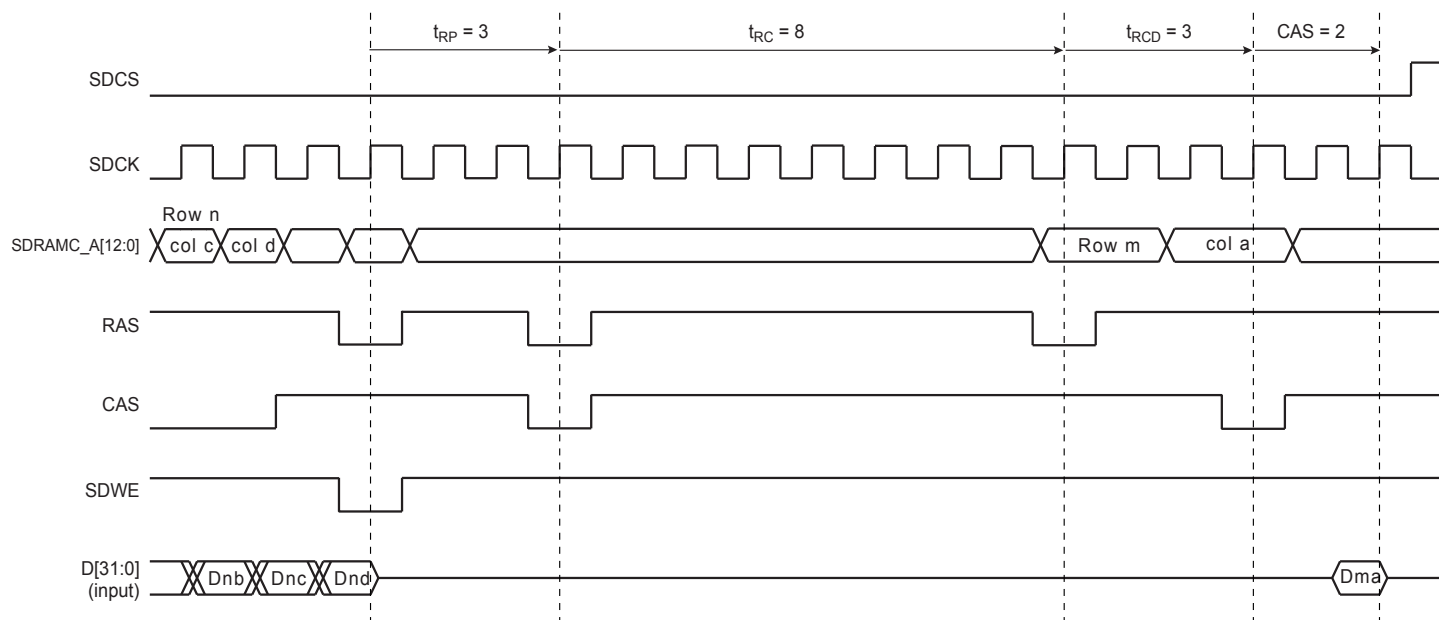

## 28.7.5 Power Management

Three low-power modes are available:

- **Self-refresh Mode:** The SDRAM executes its own Auto-refresh cycle without control of the SDRAM Controller. Current drained by the SDRAM is very low.
- **Power-down Mode:** Auto-refresh cycles are controlled by the SDRAM Controller. Between auto-refresh cycles, the SDRAM is in power-down. Current drained in Power-down mode is higher than in Self-refresh Mode.
- **Deep Power-down Mode:** (Only available with Mobile SDRAM) The SDRAM contents are lost, but the SDRAM does not drain any current.

The SDRAM Controller activates one low-power mode as soon as the SDRAM device is not selected. It is possible to delay the entry in self-refresh and power-down mode after the last access by programming a timeout value in the Low Power Register.

### 28.7.5.1 Self-refresh Mode

This mode is selected by programming the LPCB field to 1 in the SDRAMC Low Power Register. In self-refresh mode, the SDRAM device retains data without external clocking and provides its own internal clocking, thus performing its own auto-refresh cycles. All the inputs to the SDRAM device become “don’t care” except SDCKE, which remains low. As soon as the SDRAM device is selected, the SDRAM Controller provides a sequence of commands and exits self-refresh mode.

Some low-power SDRAMs (e.g., mobile SDRAM) can refresh only one quarter or a half quarter or all banks of the SDRAM array. This feature reduces the self-refresh current. To configure this feature, Temperature Compensated Self Refresh (TCSR), Partial Array Self Refresh (PASR) and Drive Strength (DS) parameters must be set in the Low Power Register and transmitted to the low-power SDRAM during initialization.

After initialization, as soon as PASR/DS/TCSR fields are modified and self-refresh mode is activated, the Extended Mode Register is accessed automatically and PASR/DS/TCSR bits are updated before entry into self-refresh mode.

The SDRAM device must remain in self-refresh mode for a minimum period of  $t_{RAS}$  and may remain in self-refresh mode for an indefinite period. This is described in [Figure 28-9](#).

**Figure 28-9.** Self-refresh Mode Behavior

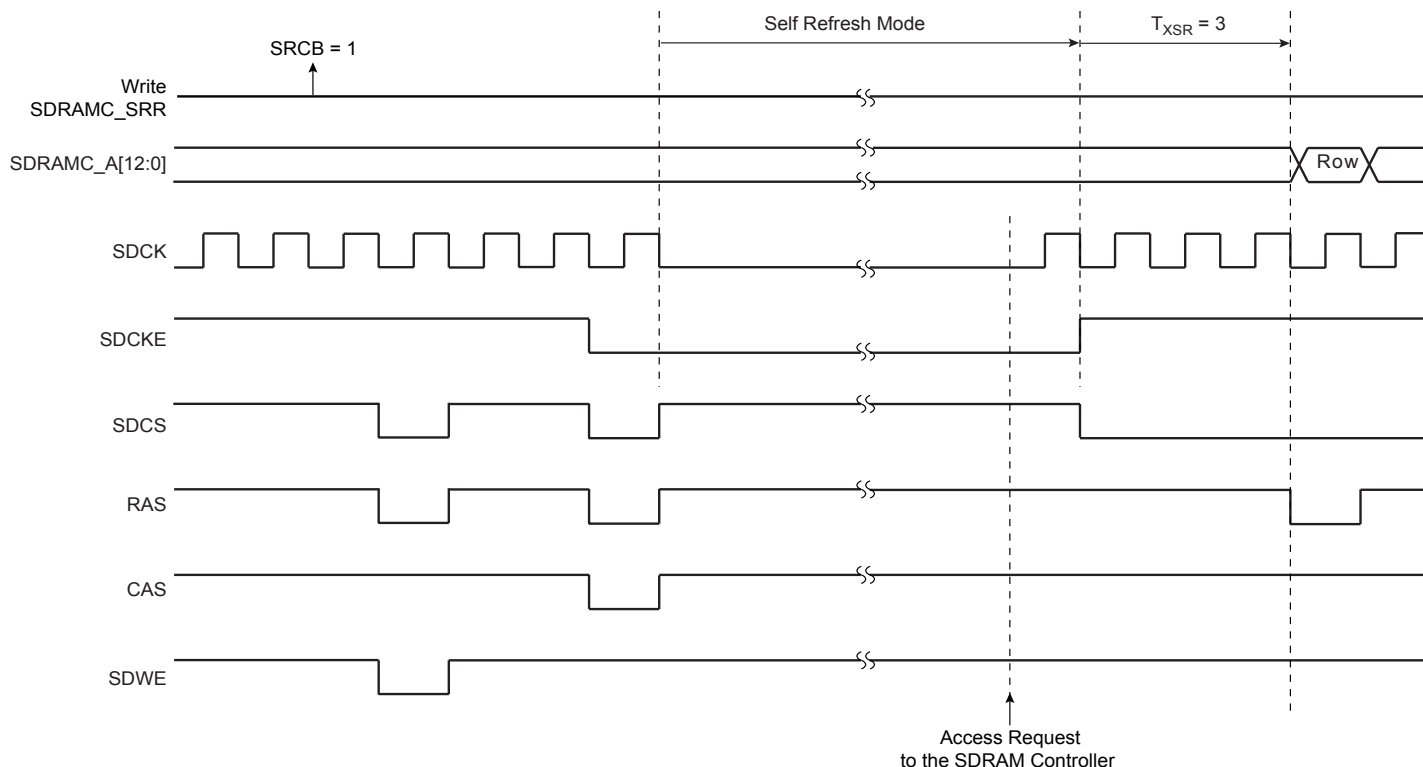

## 28.7.5.2 Low-power Mode

This mode is selected by programming the LPCB field to 2 in the SDRAMC Low Power Register. Power consumption is greater than in self-refresh mode. All the input and output buffers of the SDRAM device are deactivated except SDCKE, which remains low. In contrast to self-refresh mode, the SDRAM device cannot remain in low-power mode longer than the refresh period (64 ms for a whole device refresh operation). As no auto-refresh operations are performed by the SDRAM itself, the SDRAM Controller carries out the refresh operation. The exit procedure is faster than in self-refresh mode.

This is described in [Figure 28-10](#).

Figure 28-10. Low-power Mode Behavior

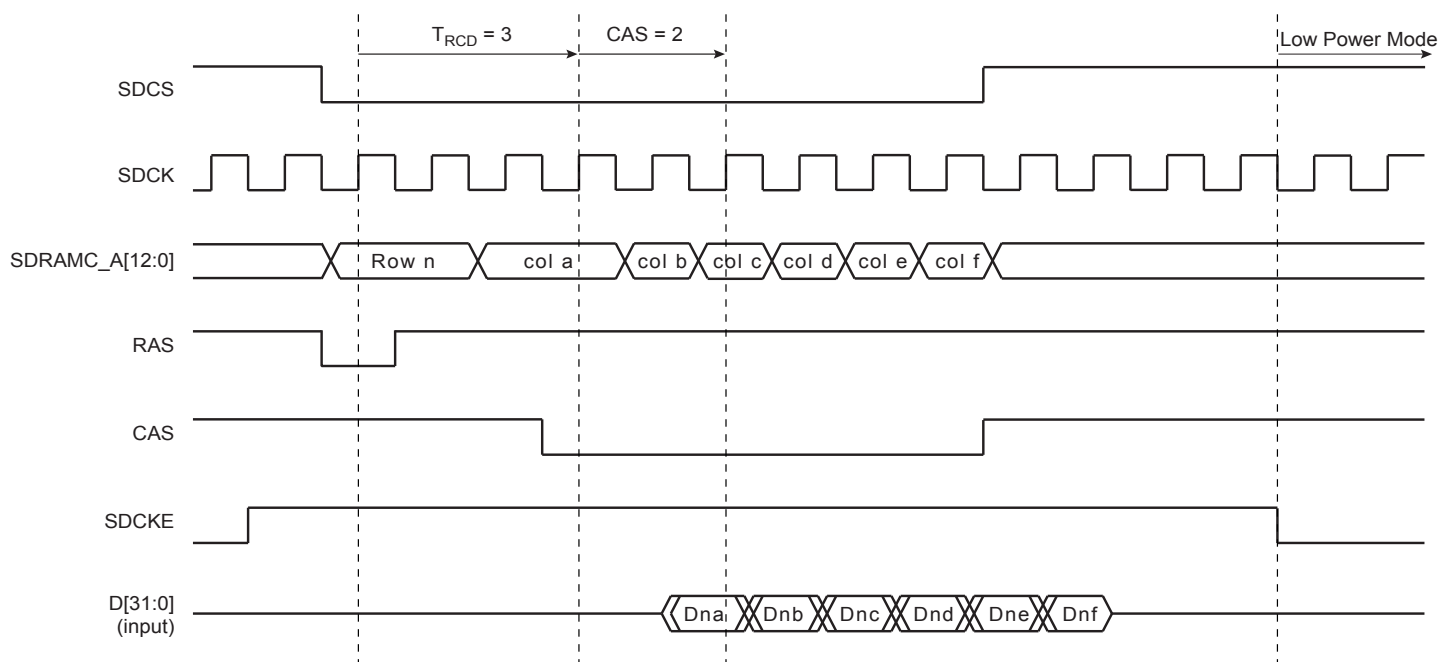

### 28.7.5.3 Deep Power-down Mode

This mode is selected by programming the LPCB field to 3 in the SDRAMC Low Power Register. When this mode is activated, all internal voltage generators inside the SDRAM are stopped and all data is lost.

When this mode is enabled, the application must not access to the SDRAM until a new initialization sequence is done (See "SDRAM Device Initialization" on page 415).

This is described in [Figure 28-11](#).

Figure 28-11. Deep Power-down Mode Behavior

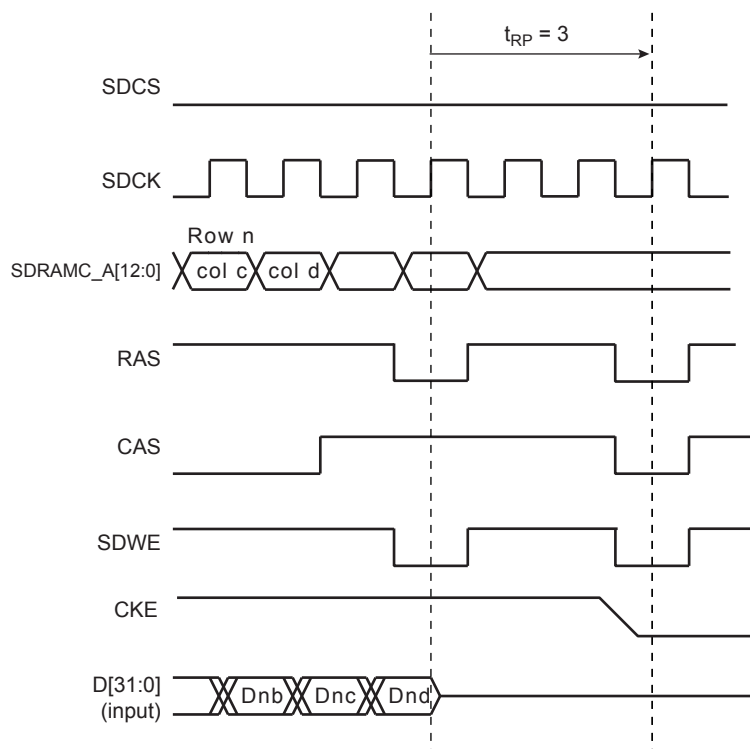

## 28.8 SDRAM Controller User Interface

**Table 28-8.** SDRAM Controller Memory Map

Offset	Register	Name	Access	Reset State
0x00	SDRAMC Mode Register	MR	Read/Write	0x00000000
0x04	SDRAMC Refresh Timer Register	TR	Read/Write	0x00000000
0x08	SDRAMC Configuration Register	CR	Read/Write	0x852372C0
0x0C	SDRAMC High Speed Register	HSR	Read/Write	0x00
0x10	SDRAMC Low Power Register	LPR	Read/Write	0x0
0x14	SDRAMC Interrupt Enable Register	IER	Write-only	–
0x18	SDRAMC Interrupt Disable Register	IDR	Write-only	–
0x1C	SDRAMC Interrupt Mask Register	IMR	Read-only	0x0
0x20	SDRAMC Interrupt Status Register	ISR	Read-only	0x0
0x24	SDRAMC Memory Device Register	MDR	Read/Write	0x0
0x28 - 0xFC	Reserved	–	–	–



## 28.8.1 SDRAMC Mode Register

Register Name: MR  
 Access Type: Read/Write  
 Reset Value: 0x00000000

31	30	29	28	27	26	25	24
–	–	–	–	–	–	–	–
23	22	21	20	19	18	17	16
–	–	–	–	–	–	–	–
15	14	13	12	11	10	9	8
–	–	–	–	–	–	–	–
7	6	5	4	3	2	1	0
–	–	–	–	–			MODE

- **MODE: SDRAMC Command Mode**

This field defines the command issued by the SDRAM Controller when the SDRAM device is accessed.

Table 28-9.

MODE			Description
0	0	0	Normal mode. Any access to the SDRAM is decoded normally.
0	0	1	The SDRAM Controller issues a NOP command when the SDRAM device is accessed regardless of the cycle.
0	1	0	The SDRAM Controller issues an “All Banks Precharge” command when the SDRAM device is accessed regardless of the cycle.
0	1	1	The SDRAM Controller issues a “Load Mode Register” command when the SDRAM device is accessed regardless of the cycle. The command will load the CAS latency from the Configuration Register and every other value set to 0 into the Mode Register.
1	0	0	The SDRAM Controller issues an “Auto-Refresh” Command when the SDRAM device is accessed regardless of the cycle. Previously, an “All Banks Precharge” command must be issued.
1	0	1	The SDRAM Controller issues an extended load mode register command when the SDRAM device is accessed regardless of the cycle. The command will load the PASR, DS and TCR from the Low Power Register and every other value set to 0 into the Extended Mode Register.
1	1	0	Deep power-down mode. Enters deep power-down mode.

## 28.8.2 SDRAMC Refresh Timer Register

**Register Name:** TR  
**Access Type:** Read/Write  
**Reset Value:** 0x00000000

31	30	29	28	27	26	25	24
-	-	-	-	-	-	-	-
23	22	21	20	19	18	17	16
-	-	-	-	-	-	-	-
15	14	13	12	11	10	9	8
-	-	-	-	COUNT			
7	6	5	4	3	2	1	0
COUNT							

- **COUNT: SDRAMC Refresh Timer Count**

This 12-bit field is loaded into a timer that generates the refresh pulse. Each time the refresh pulse is generated, a refresh burst is initiated. The value to be loaded depends on the SDRAMC clock frequency (MCK: Master Clock), the refresh rate of the SDRAM device and the refresh burst length where 15.6  $\mu$ s per row is a typical value for a burst of length one.

To refresh the SDRAM device, this 12-bit field must be written. If this condition is not satisfied, no refresh command is issued and no refresh of the SDRAM device is carried out.

## 28.8.3 SDRAMC Configuration Register

Register Name: CR  
 Access Type: Read/Write  
 Reset Value: 0x852372C0

31	30	29	28	27	26	25	24
TXSR				TRAS			
23	22	21	20	19	18	17	16
TRCD				TRP			
15	14	13	12	11	10	9	8
TRC				TWR			
7	6	5	4	3	2	1	0
DBW	CAS		NB	NR		NC	

• **NC: Number of Column Bits**

Reset value is 8 column bits.

NC		Column Bits
0	0	8
0	1	9
1	0	10
1	1	11

• **NR: Number of Row Bits**

Reset value is 11 row bits.

NR		Row Bits
0	0	11
0	1	12
1	0	13
1	1	Reserved

• **NB: Number of Banks**

Reset value is two banks.

NB	Number of Banks
0	2
1	4

- **CAS: CAS Latency**

Reset value is two cycles.

In the SDRAMC, only a CAS latency of one, two and three cycles is managed.

CAS		CAS Latency (Cycles)
0	0	Reserved
0	1	1
1	0	2
1	1	3

- **DBW: Data Bus Width**

Reset value is 16 bits

0: Data bus width is 32 bits.

1: Data bus width is 16 bits.

- **TWR: Write Recovery Delay**

Reset value is two cycles.

This field defines the Write Recovery Time in number of cycles. Number of cycles is between 0 and 15.

- **TRC: Row Cycle Delay**

Reset value is seven cycles.

This field defines the delay between a Refresh and an Activate Command in number of cycles. Number of cycles is between 0 and 15.

- **TRP: Row Precharge Delay**

Reset value is three cycles.

This field defines the delay between a Precharge Command and another Command in number of cycles. Number of cycles is between 0 and 15.

- **TRCD: Row to Column Delay**

Reset value is two cycles.

This field defines the delay between an Activate Command and a Read/Write Command in number of cycles. Number of cycles is between 0 and 15.

- **TRAS: Active to Precharge Delay**

Reset value is five cycles.

This field defines the delay between an Activate Command and a Precharge Command in number of cycles. Number of cycles is between 0 and 15.

- **TXSR: Exit Self Refresh to Active Delay**

Reset value is height cycles.

This field defines the delay between SCKE set high and an Activate Command in number of cycles. Number of cycles is between 0 and 15.

## 28.8.4 SDRAMC High Speed Register

Register Name: HSR

Access Type: Read/Write

31	30	29	28	27	26	25	24
–	–	–	–	–	–	–	–
23	22	21	20	19	18	17	16
–	–	–	–	–	–	–	–
15	14	13	12	11	10	9	8
–	–	–	–	–	–	–	–
7	6	5	4	3	2	1	0
–	–	–	–	–	–	–	DA

- **DA: Decode Cycle Enable**

A decode cycle can be added on the addresses as soon as a non-sequential access is performed on the HSB bus.

The addition of the decode cycle allows the SDRAMC to gain time to access the SDRAM memory.

0: Decode cycle is disabled.

1: Decode cycle is enabled.

## 28.8.5 SDRAMC Low Power Register

Register Name: LPR  
 Access Type: Read/Write  
 Reset Value: 0x0

31	30	29	28	27	26	25	24
-	-	-	-	-	-	-	-
23	22	21	20	19	18	17	16
-	-	-	-	-	-	-	-
15	14	13	12	11	10	9	8
-	-	TIMEOUT		DS		TCSR	
7	6	5	4	3	2	1	0
-	PASR			-	-	LPCB	

- **LPCB: Low-power Configuration Bits**

00	Low Power Feature is inhibited: no Power-down, Self-refresh or Deep Power-down command is issued to the SDRAM device.
01	The SDRAM Controller issues a Self-refresh command to the SDRAM device, the SDCLK clock is deactivated and the SDCKE signal is set low. The SDRAM device leaves the Self Refresh Mode when accessed and enters it after the access.
10	The SDRAM Controller issues a Power-down Command to the SDRAM device after each access, the SDCKE signal is set to low. The SDRAM device leaves the Power-down Mode when accessed and enters it after the access.
11	The SDRAM Controller issues a Deep Power-down command to the SDRAM device. This mode is unique to low-power SDRAM.

- **PASR: Partial Array Self-refresh (only for low-power SDRAM)**

PASR parameter is transmitted to the SDRAM during initialization to specify whether only one quarter, one half or all banks of the SDRAM array are enabled. Disabled banks are not refreshed in self-refresh mode. This parameter must be set according to the SDRAM device specification.

After initialization, as soon as PASR field is modified and self-refresh mode is activated, the Extended Mode Register is accessed automatically and PASR bits are updated before entry in self-refresh mode.

- **TCSR: Temperature Compensated Self-Refresh (only for low-power SDRAM)**

TCSR parameter is transmitted to the SDRAM during initialization to set the refresh interval during self-refresh mode depending on the temperature of the low-power SDRAM. This parameter must be set according to the SDRAM device specification.

After initialization, as soon as TCSR field is modified and self-refresh mode is activated, the Extended Mode Register is accessed automatically and TCSR bits are updated before entry in self-refresh mode.

- **DS: Drive Strength (only for low-power SDRAM)**

DS parameter is transmitted to the SDRAM during initialization to select the SDRAM strength of data output. This parameter must be set according to the SDRAM device specification.

After initialization, as soon as DS field is modified and self-refresh mode is activated, the Extended Mode Register is accessed automatically and DS bits are updated before entry in self-refresh mode.

- **TIMEOUT:** Time to define when low-power mode is enabled

00	The SDRAM controller activates the SDRAM low-power mode immediately after the end of the last transfer.
01	The SDRAM controller activates the SDRAM low-power mode 64 clock cycles after the end of the last transfer.
10	The SDRAM controller activates the SDRAM low-power mode 128 clock cycles after the end of the last transfer.
11	Reserved.

28.8.6 SDRAMC Interrupt Enable Register

Register Name: IER

Access Type: Write-only

31	30	29	28	27	26	25	24
–	–	–	–	–	–	–	–
23	22	21	20	19	18	17	16
–	–	–	–	–	–	–	–
15	14	13	12	11	10	9	8
–	–	–	–	–	–	–	–
7	6	5	4	3	2	1	0
–	–	–	–	–	–	–	RES

• RES: Refresh Error Status

0: No effect.

1: Enables the refresh error interrupt.



28.8.7 SDRAMC Interrupt Disable Register

Register Name: IDR

Access Type: Write-only

31	30	29	28	27	26	25	24
–	–	–	–	–	–	–	–
23	22	21	20	19	18	17	16
–	–	–	–	–	–	–	–
15	14	13	12	11	10	9	8
–	–	–	–	–	–	–	–
7	6	5	4	3	2	1	0
–	–	–	–	–	–	–	RES

• RES: Refresh Error Status

0: No effect.

1: Disables the refresh error interrupt.

28.8.8 SDRAMC Interrupt Mask Register

Register Name: IMR

Access Type: Read-only

31	30	29	28	27	26	25	24
–	–	–	–	–	–	–	–
23	22	21	20	19	18	17	16
–	–	–	–	–	–	–	–
15	14	13	12	11	10	9	8
–	–	–	–	–	–	–	–
7	6	5	4	3	2	1	0
–	–	–	–	–	–	–	RES

• RES: Refresh Error Status

0: The refresh error interrupt is disabled.

1: The refresh error interrupt is enabled.

28.8.9 SDRAMC Interrupt Status Register

Register Name: ISR

Access Type: Read-only

31	30	29	28	27	26	25	24
–	–	–	–	–	–	–	–
23	22	21	20	19	18	17	16
–	–	–	–	–	–	–	–
15	14	13	12	11	10	9	8
–	–	–	–	–	–	–	–
7	6	5	4	3	2	1	0
–	–	–	–	–	–	–	RES

• RES: Refresh Error Status

0: No refresh error has been detected since the register was last read.

1: A refresh error has been detected since the register was last read.

## 28.8.10 SDRAMC Memory Device Register

**Register Name:** MDR

**Access Type:** Read/Write

31	30	29	28	27	26	25	24
–	–	–	–	–	–	–	–
23	22	21	20	19	18	17	16
–	–	–	–	–	–	–	–
15	14	13	12	11	10	9	8
–	–	–	–	–	–	–	–
7	6	5	4	3	2	1	0
–	–	–	–	–	–	MD	

• **MD: Memory Device Type**

00	SDRAM
01	Low-power SDRAM
10	Reserved
11	Reserved.

## 29. Ethernet MAC (MACB)

Rev: 1.1.2.5

### 29.1 Features

- **Compatible with IEEE Standard 802.3**
- **10 and 100 Mbit/s Operation**
- **Full- and Half-duplex Operation**
- **Statistics Counter Registers**
- **MII/RMII Interface to the Physical Layer**
- **Interrupt Generation to Signal Receive and Transmit Completion**
- **DMA Master on Receive and Transmit Channels**
- **Transmit and Receive FIFOs**
- **Automatic Pad and CRC Generation on Transmitted Frames**
- **Automatic Discard of Frames Received with Errors**
- **Address Checking Logic Supports Up to Four Specific 48-bit Addresses**
- **Supports Promiscuous Mode Where All Valid Received Frames are Copied to Memory**
- **Hash Matching of Unicast and Multicast Destination Addresses**
- **External Address Matching of Received Frames**
- **Physical Layer Management through MDIO Interface**
- **Half-duplex Flow Control by Forcing Collisions on Incoming Frames**
- **Full-duplex Flow Control with Recognition of Incoming Pause Frames and Hardware Generation of Transmitted Pause Frames**
- **Support for 802.1Q VLAN Tagging with Recognition of Incoming VLAN and Priority Tagged Frames**
- **Multiple Buffers per Receive and Transmit Frame**
- **Wake-on-LAN Support**
- **Jumbo Frames Up to 10240 bytes Supported**

### 29.2 Description

The MACB module implements a 10/100 Ethernet MAC compatible with the IEEE 802.3 standard using an address checker, statistics and control registers, receive and transmit blocks, and a DMA interface.

The address checker recognizes four specific 48-bit addresses and contains a 64-bit hash register for matching multicast and unicast addresses. It can recognize the broadcast address of all ones, copy all frames, and act on an external address match signal.

The statistics register block contains registers for counting various types of events associated with transmit and receive operations. These registers, along with the status words stored in the receive buffer list, enable software to generate network management statistics compatible with IEEE 802.3.

## 29.3 Block Diagram

Figure 29-1. MACB Block Diagram

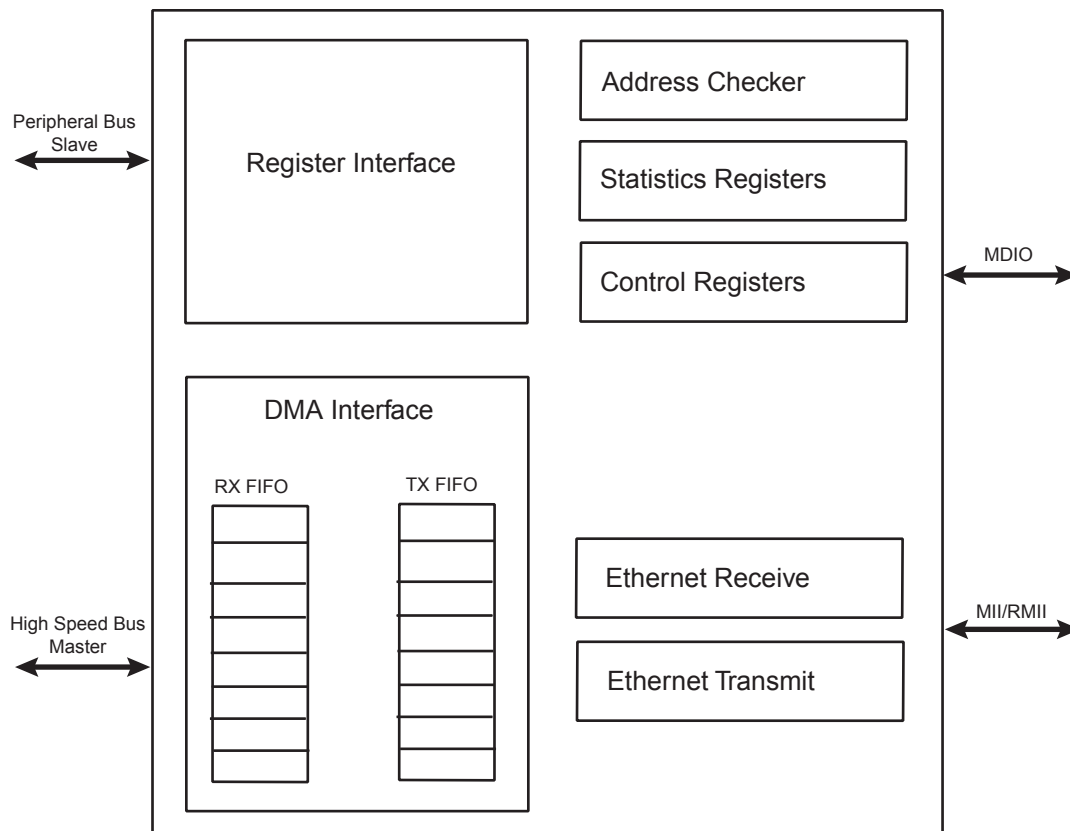

## 29.4 Product Dependencies

### 29.4.1 I/O Lines

The pins used for interfacing the compliant external devices may be multiplexed with PIO lines. The programmer must first program the PIO controllers to assign the MACB pins to their peripheral functions.

### 29.4.2 Power Management

The MACB clock is generated by the Power Manager. Before using the MACB, the programmer must ensure that the MACB clock is enabled in the Power Manager.

In the MACB description, Master Clock (MCK) is the clock of the peripheral bus to which the MACB is connected.

The synchronization module in the MACB requires that the bus clock (hclk) runs on at least the speed of the `macb_tx/rx_clk`, which is 25MHz in 100Mbps, and 2.5MHz in 10Mbps in MII mode and 50MHz in 100Mbps, and 5MHz in 10Mbps in RMI mode.

To prevent bus errors the MACB operation must be terminated before entering sleep mode.

### 29.4.3 Interrupt

The MACB interface has an interrupt line connected to the Interrupt Controller. Handling the MACB interrupt requires programming the interrupt controller before configuring the MACB.

## 29.5 Functional Description

Figure 29-1 on page 438 illustrates the different blocks of the MACB module.

The control registers drive the MDIO interface, setup DMA activity, start frame transmission and select modes of operation such as full- or half-duplex.

The receive block checks for valid preamble, FCS, alignment and length, and presents received frames to the address checking block and DMA interface.

The transmit block takes data from the DMA interface, adds preamble and, if necessary, pad and FCS, and transmits data according to the CSMA/CD (carrier sense multiple access with collision detect) protocol. The start of transmission is deferred if CRS (carrier sense) is active.

If COL (collision) becomes active during transmission, a jam sequence is asserted and the transmission is retried after a random back off. CRS and COL have no effect in full duplex mode.

The DMA block connects to external memory through its high speed bus (HSB) interface. It contains receive and transmit FIFOs for buffering frame data. It loads the transmit FIFO and empties the receive FIFO using HSB bus master operations. Receive data is not sent to memory until the address checking logic has determined that the frame should be copied. Receive or transmit frames are stored in one or more buffers. Receive buffers have a fixed length of 128 bytes. Transmit buffers range in length between 0 and 2047 bytes, and up to 128 buffers are permitted per frame. The DMA block manages the transmit and receive framebuffer queues. These queues can hold multiple frames.

### 29.5.1 Memory Interface

Frame data is transferred to and from the MACB through the DMA interface. All transfers are 32-bit words and may be single accesses or bursts of 2, 3 or 4 words. Burst accesses do not cross sixteen-byte boundaries. Bursts of 4 words are the default data transfer; single accesses or bursts of less than four words may be used to transfer data at the beginning or the end of a buffer.

The DMA controller performs six types of operation on the bus. In order of priority, these are:

1. Receive buffer manager write
2. Receive buffer manager read
3. Transmit data DMA read
4. Receive data DMA write
5. Transmit buffer manager read
6. Transmit buffer manager write

#### 29.5.1.1 FIFO

The FIFO depths are 124 bytes.

Data is typically transferred into and out of the FIFOs in bursts of four words. For receive, a bus request is asserted when the FIFO contains four words and has space for three more. For transmit, a bus request is generated when there is space for four words, or when there is space for two words if the next transfer is to be only one or two words.

Thus the bus latency must be less than the time it takes to load the FIFO and transmit or receive three words (12 bytes) of data.

At 100 Mbit/s, it takes 960 ns to transmit or receive 12 bytes of data. In addition, six master clock cycles should be allowed for data to be loaded from the bus and to propagate through the FIFOs. For a 60 MHz master clock this takes 100 ns, making the bus latency requirement 860 ns.

### 29.5.1.2 Receive Buffers

Received frames, optionally including CRC/FCS, are written to receive buffers stored in memory. Each receive buffer is 128 bytes long. The start location for each receive buffer is stored in memory in a list of receive buffer descriptors at a location pointed to by the receive buffer queue pointer register. The receive buffer start location is a word address. For the first buffer of a frame, the start location can be offset by up to three bytes depending on the value written to bits 14 and 15 of the network configuration register. If the start location of the buffer is offset the available length of the first buffer of a frame is reduced by the corresponding number of bytes.

Each list entry consists of two words, the first being the address of the receive buffer and the second being the receive status. If the length of a receive frame exceeds the buffer length, the status word for the used buffer is written with zeroes except for the “start of frame” bit and the offset bits, if appropriate. Bit zero of the address field is written to one to show the buffer has been used. The receive buffer manager then reads the location of the next receive buffer and fills that with receive frame data. The final buffer descriptor status word contains the complete frame status. Refer to [Table 29-1](#) for details of the receive buffer descriptor list.

**Table 29-1.** Receive Buffer Descriptor Entry

Bit	Function
Word 0	
31:2	Address of beginning of buffer
1	Wrap - marks last descriptor in receive buffer descriptor list.
0	Ownership - needs to be zero for the MACB to write data to the receive buffer. The MACB sets this to one once it has successfully written a frame to memory. Software has to clear this bit before the buffer can be used again.
Word 1	
31	Global all ones broadcast address detected
30	Multicast hash match
29	Unicast hash match
28	External address match
27	Reserved for future use
26	Specific address register 1 match
25	Specific address register 2 match
24	Specific address register 3 match
23	Specific address register 4 match
22	Type ID match
21	VLAN tag detected (i.e., type id of 0x8100)



**Table 29-1.** Receive Buffer Descriptor Entry (Continued)

Bit	Function
20	Priority tag detected (i.e., type id of 0x8100 and null VLAN identifier)
19:17	VLAN priority (only valid if bit 21 is set)
16	Concatenation format indicator (CFI) bit (only valid if bit 21 is set)
15	End of frame - when set the buffer contains the end of a frame. If end of frame is not set, then the only other valid status are bits 12, 13 and 14.
14	Start of frame - when set the buffer contains the start of a frame. If both bits 15 and 14 are set, then the buffer contains a whole frame.
13:12	Receive buffer offset - indicates the number of bytes by which the data in the first buffer is offset from the word address. Updated with the current values of the network configuration register. If jumbo frame mode is enabled through bit 3 of the network configuration register, then bits 13:12 of the receive buffer descriptor entry are used to indicate bits 13:12 of the frame length.
11:0	Length of frame including FCS (if selected). Bits 13:12 are also used if jumbo frame mode is selected.

To receive frames, the buffer descriptors must be initialized by writing an appropriate address to bits 31 to 2 in the first word of each list entry. Bit zero must be written with zero. Bit one is the wrap bit and indicates the last entry in the list.

The start location of the receive buffer descriptor list must be written to the receive buffer queue pointer register before setting the receive enable bit in the network control register to enable receive. As soon as the receive block starts writing received frame data to the receive FIFO, the receive buffer manager reads the first receive buffer location pointed to by the receive buffer queue pointer register.

If the filter block then indicates that the frame should be copied to memory, the receive data DMA operation starts writing data into the receive buffer. If an error occurs, the buffer is recovered. If the current buffer pointer has its wrap bit set or is the 1024<sup>th</sup> descriptor, the next receive buffer location is read from the beginning of the receive descriptor list. Otherwise, the next receive buffer location is read from the next word in memory.

There is an 11-bit counter to count out the 2048 word locations of a maximum length, receive buffer descriptor list. This is added with the value originally written to the receive buffer queue pointer register to produce a pointer into the list. A read of the receive buffer queue pointer register returns the pointer value, which is the queue entry currently being accessed. The counter is reset after receive status is written to a descriptor that has its wrap bit set or rolls over to zero after 1024 descriptors have been accessed. The value written to the receive buffer pointer register may be any word-aligned address, provided that there are at least 2048 word locations available between the pointer and the top of the memory.

The System Bus specification states that bursts should not cross 1K boundaries. As receive buffer manager writes are bursts of two words, to ensure that this does not occur, it is best to write the pointer register with the least three significant bits set to zero. As receive buffers are used, the receive buffer manager sets bit zero of the first word of the descriptor to indicate *used*. If a receive error is detected the receive buffer currently being written is recovered. Previous buffers are not recovered. Software should search through the *used* bits in the buffer descriptors to find out how many frames have been received. It should be checking the start-of-frame and end-of-frame bits, and not rely on the value returned by the receive buffer queue pointer register which changes continuously as more buffers are used.

For CRC errored frames, excessive length frames or length field mismatched frames, all of which are counted in the statistics registers, it is possible that a frame fragment might be stored in a sequence of receive buffers. Software can detect this by looking for start of frame bit set in a buffer following a buffer with no end of frame bit set.

For a properly working Ethernet system, there should be no excessively long frames or frames greater than 128 bytes with CRC/FCS errors. Collision fragments are less than 128 bytes long. Therefore, it is a rare occurrence to find a frame fragment in a receive buffer.

If bit zero is set when the receive buffer manager reads the location of the receive buffer, then the buffer has already been used and cannot be used again until software has processed the frame and cleared bit zero. In this case, the DMA block sets the buffer not available bit in the receive status register and triggers an interrupt.

If bit zero is set when the receive buffer manager reads the location of the receive buffer and a frame is being received, the frame is discarded and the receive resource error statistics register is incremented.

A receive overrun condition occurs when bus was not granted in time or because HRESP was not OK (bus error). In a receive overrun condition, the receive overrun interrupt is asserted and the buffer currently being written is recovered. The next frame received with an address that is recognized reuses the buffer.

If bit 17 of the network configuration register is set, the FCS of received frames shall not be copied to memory. The frame length indicated in the receive status field shall be reduced by four bytes in this case.

### 29.5.1.3 Transmit Buffer

Frames to be transmitted are stored in one or more transmit buffers. Transmit buffers can be between 0 and 2047 bytes long, so it is possible to transmit frames longer than the maximum length specified in IEEE Standard 802.3. Zero length buffers are allowed. The maximum number of buffers permitted for each transmit frame is 128.

The start location for each transmit buffer is stored in memory in a list of transmit buffer descriptors at a location pointed to by the transmit buffer queue pointer register. Each list entry consists of two words, the first being the byte address of the transmit buffer and the second containing the transmit control and status. Frames can be transmitted with or without automatic CRC generation. If CRC is automatically generated, padding is also automatically generated to take frames to a minimum length of 64 bytes. [Table 29-2 on page 443](#) defines an entry in the transmit buffer descriptor list. To transmit frames, the buffer descriptors must be initialized by writing an appropriate byte address to bits 31 to 0 in the first word of each list entry. The second transmit buffer descriptor is initialized with control information that indicates the length of the buffer, whether or not it is to be transmitted with CRC and whether the buffer is the last buffer in the frame.

After transmission, the control bits are written back to the second word of the first buffer along with the “used” bit and other status information. Before a transmission, bit 31 is the “used” bit which must be zero when the control word is read. It is written to one when a frame has been transmitted. Bits 27, 28 and 29 indicate various transmit error conditions. Bit 30 is the “wrap” bit which can be set for any buffer within a frame. If no wrap bit is encountered after 1024 descriptors, the queue pointer rolls over to the start.

The transmit buffer queue pointer register must not be written while transmit is active. If a new value is written to the transmit buffer queue pointer register, the queue pointer resets itself to

point to the beginning of the new queue. If transmit is disabled by writing to bit 3 of the network control, the transmit buffer queue pointer register resets to point to the beginning of the transmit queue. Note that disabling receive does not have the same effect on the receive queue pointer.

Once the transmit queue is initialized, transmit is activated by writing to bit 9, the *Transmit Start* bit of the network control register. Transmit is halted when a buffer descriptor with its *used* bit set is read, or if a transmit error occurs, or by writing to the transmit halt bit of the network control register. (Transmission is suspended if a pause frame is received while the pause enable bit is set in the network configuration register.) Rewriting the start bit while transmission is active is allowed.

Transmission control is implemented with a Tx\_go variable which is readable in the transmit status register at bit location 3. The Tx\_go variable is reset when:

- transmit is disabled
- a buffer descriptor with its ownership bit set is read
- a new value is written to the transmit buffer queue pointer register
- bit 10, tx\_halt, of the network control register is written
- there is a transmit error such as too many retries or a transmit underrun.

To set tx\_go, write to bit 9, tx\_start, of the network control register. Transmit halt does not take effect until any ongoing transmit finishes. If a collision occurs during transmission of a multi-buffer frame, transmission automatically restarts from the first buffer of the frame. If a “used” bit is read midway through transmission of a multi-buffer frame, this is treated as a transmit error. Transmission stops, tx\_er is asserted and the FCS is bad.

If transmission stops due to a transmit error, the transmit queue pointer resets to point to the beginning of the transmit queue. Software needs to re-initialize the transmit queue after a transmit error.

If transmission stops due to a “used” bit being read at the start of the frame, the transmission queue pointer is not reset and transmit starts from the same transmit buffer descriptor when the transmit start bit is written

**Table 29-2.** Transmit Buffer Descriptor Entry

Bit	Function
Word 0	
31:0	<b>Byte Address of buffer</b>
Word 1	
31	Used. Needs to be zero for the MACB to read data from the transmit buffer. The MACB sets this to one for the first buffer of a frame once it has been successfully transmitted. Software has to clear this bit before the buffer can be used again. Note: This bit is only set for the first buffer in a frame unlike receive where all buffers have the Used bit set once used.
30	Wrap. Marks last descriptor in transmit buffer descriptor list.
29	Retry limit exceeded, transmit error detected
28	Transmit underrun, occurs either when hresp is not OK (bus error) or the transmit data could not be fetched in time or when buffers are exhausted in mid frame.
27	Buffers exhausted in mid frame
26:17	Reserved

**Table 29-2.** Transmit Buffer Descriptor Entry (Continued)

Bit	Function
16	No CRC. When set, no CRC is appended to the current frame. This bit only needs to be set for the last buffer of a frame.
15	Last buffer. When set, this bit indicates the last buffer in the current frame has been reached.
14:11	Reserved
10:0	Length of buffer

### 29.5.2 Transmit Block

This block transmits frames in accordance with the Ethernet IEEE 802.3 CSMA/CD protocol. Frame assembly starts by adding preamble and the start frame delimiter. Data is taken from the transmit FIFO a word at a time. Data is transmitted least significant nibble first. If necessary, padding is added to increase the frame length to 60 bytes. CRC is calculated as a 32-bit polynomial. This is inverted and appended to the end of the frame, taking the frame length to a minimum of 64 bytes. If the No CRC bit is set in the second word of the last buffer descriptor of a transmit frame, neither pad nor CRC are appended.

In full-duplex mode, frames are transmitted immediately. Back-to-back frames are transmitted at least 96 bit times apart to guarantee the interframe gap.

In half-duplex mode, the transmitter checks carrier sense. If asserted, it waits for it to de-assert and then starts transmission after the interframe gap of 96 bit times. If the collision signal is asserted during transmission, the transmitter transmits a jam sequence of 32 bits taken from the data register and retries transmission after the back off time has elapsed.

The back-off time is based on an XOR of the 10 least significant bits of the data coming from the transmit FIFO and a 10-bit pseudo random number. The number of bits used depends on the number of collisions seen. After the first collision, 1 bit is used, after the second 2, and so on up to 10. Above 10, all 10 bits are used. An error is indicated and no further attempts are made if 16 attempts cause collisions.

If transmit DMA underruns, bad CRC is automatically appended using the same mechanism as jam insertion and the TX\_ER signal is asserted. In a properly configured system, this should never happen.

If the back pressure bit is set in the network control register in half duplex mode, the transmit block transmits 64 bits of data, which can consist of 16 nibbles of 1011 or in bit-rate mode 64 1s, whenever it sees an incoming frame to force a collision. This provides a way of implementing flow control in half-duplex mode.

### 29.5.3 Pause Frame Support

The start of an 802.3 pause frame is as follows:

**Table 29-3.** Start of an 802.3 Pause Frame

Destination Address	Source Address	Type (Mac Control Frame)	Pause Opcode	Pause Time
0x0180C2000001	6 bytes	0x8808	0x0001	2 bytes

The network configuration register contains a receive pause enable bit (13). If a valid pause frame is received, the pause time register is updated with the frame's pause time, regardless of

its current contents and regardless of the state of the configuration register bit 13. An interrupt (12) is triggered when a pause frame is received, assuming it is enabled in the interrupt mask register. If bit 13 is set in the network configuration register and the value of the pause time register is non-zero, no new frame is transmitted until the pause time register has decremented to zero.

The loading of a new pause time, and hence the pausing of transmission, only occurs when the MACB is configured for full-duplex operation. If the MACB is configured for half-duplex, there is no transmission pause, but the pause frame received interrupt is still triggered.

A valid pause frame is defined as having a destination address that matches either the address stored in specific address register 1 or matches 0x0180C200001 and has the MAC control frame type ID of 0x8808 and the pause opcode of 0x0001. Pause frames that have FCS or other errors are treated as invalid and are discarded. Valid pause frames received increment the Pause Frame Received statistic register.

The pause time register decrements every 512 bit times (i.e., 128 `rx_clks` in nibble mode) once transmission has stopped. For test purposes, the register decrements every `rx_clk` cycle once transmission has stopped if bit 12 (retry test) is set in the network configuration register. If the pause enable bit (13) is not set in the network configuration register, then the decrementing occurs regardless of whether transmission has stopped or not.

An interrupt (13) is asserted whenever the pause time register decrements to zero (assuming it is enabled in the interrupt mask register). Automatic transmission of pause frames is supported through the transmit pause frame bits of the network control register and the `tx_pause` and `tx_pause_zero` inputs. If either bit 11 or bit 12 of the network control register is written to with a 1, or if the input signal `tx_pause` is toggled, a pause frame is transmitted only if full duplex is selected in the network configuration register and transmit is enabled in the network control register.

Pause frame transmission occurs immediately if transmit is inactive or if transmit is active between the current frame and the next frame due to be transmitted. The transmitted pause frame is comprised of the items in the following list:

- a destination address of 01-80-C2-00-00-01
- a source address taken from the specific address 1 register
- a type ID of 88-08 (MAC control frame)
- a pause opcode of 00-01
- a pause quantum
- fill of 00 to take the frame to minimum frame length
- valid FCS

The pause quantum used in the generated frame depends on the trigger source for the frame as follows:

1. If bit 11 is written with a one, the pause quantum comes from the transmit pause quantum register. The Transmit Pause Quantum register resets to a value of 0xFFFF giving a maximum pause quantum as a default.
2. If bit 12 is written with a one, the pause quantum is zero.
3. If the `tx_pause` input is toggled and the `tx_pause_zero` input is held low until the next toggle, the pause quantum comes from the transmit pause quantum register.
4. If the `tx_pause` input is toggled and the `tx_pause_zero` input is held high until the next toggle, the pause quantum is zero.

After transmission, no interrupts are generated and the only statistics register that is incremented is the pause frames transmitted register.

#### 29.5.4 Receive Block

The receive block checks for valid preamble, FCS, alignment and length, presents received frames to the DMA block and stores the frames destination address for use by the address checking block. If, during frame reception, the frame is found to be too long or rx\_er is asserted, a bad frame indication is sent to the DMA block. The DMA block then ceases sending data to memory. At the end of frame reception, the receive block indicates to the DMA block whether the frame is good or bad. The DMA block recovers the current receive buffer if the frame was bad. The receive block signals the register block to increment the alignment error, the CRC (FCS) error, the short frame, long frame, jabber error, the receive symbol error statistics and the length field mismatch statistics.

The enable bit for jumbo frames in the network configuration register allows the MACB to receive jumbo frames of up to 10240 bytes in size. This operation does not form part of the IEEE802.3 specification and is disabled by default. When jumbo frames are enabled, frames received with a frame size greater than 10240 bytes are discarded.

#### 29.5.5 Address Checking Block

The address checking (or filter) block indicates to the DMA block which receive frames should be copied to memory. Whether a frame is copied depends on what is enabled in the network configuration register, the state of the external match pin, the contents of the specific address and hash registers and the frame's destination address. In this implementation of the MACB, the frame's source address is not checked. Provided that bit 18 of the Network Configuration register is not set, a frame is not copied to memory if the MACB is transmitting in half duplex mode at the time a destination address is received. If bit 18 of the Network Configuration register is set, frames can be received while transmitting in half-duplex mode.

Ethernet frames are transmitted a byte at a time, least significant bit first. The first six bytes (48 bits) of an Ethernet frame make up the destination address. The first bit of the destination address, the LSB of the first byte of the frame, is the group/individual bit: this is *One* for multicast addresses and *Zero* for unicast. The *All Ones* address is the broadcast address, and a special case of multicast.

The MACB supports recognition of four specific addresses. Each specific address requires two registers, specific address register bottom and specific address register top. Specific address register bottom stores the first four bytes of the destination address and specific address register top contains the last two bytes. The addresses stored can be specific, group, local or universal.

The destination address of received frames is compared against the data stored in the specific address registers once they have been activated. The addresses are deactivated at reset or when their corresponding specific address register bottom is written. They are activated when specific address register top is written. If a receive frame address matches an active address, the frame is copied to memory.

The following example illustrates the use of the address match registers for a MAC address of 21:43:65:87:A9:CB.

Preamble 55  
 SFD D5  
 DA (Octet0 - LSB) 21  
 DA(Octet 1) 43  
 DA(Octet 2) 65  
 DA(Octet 3) 87  
 DA(Octet 4) A9  
 DA (Octet5 - MSB) CB  
 SA (LSB) 00  
 SA 00  
 SA 00  
 SA 00  
 SA 00  
 SA (MSB) 43  
 SA (LSB) 21

The sequence above shows the beginning of an Ethernet frame. Byte order of transmission is from top to bottom as shown. For a successful match to specific address 1, the following address matching registers must be set up:

- Base address + 0x98 0x87654321 (Bottom)
- Base address + 0x9C 0x0000CBA9 (Top)

And for a successful match to the Type ID register, the following should be set up:

- Base address + 0xB8 0x00004321

### 29.5.6 Broadcast Address

The broadcast address of 0xFFFFFFFF is recognized unless the 'no broadcast' bit in the network configuration register is set.

### 29.5.7 Hash Addressing

The hash address register is 64 bits long and takes up two locations in the memory map. The least significant bits are stored in hash register bottom and the most significant bits in hash register top.

The unicast hash enable and the multicast hash enable bits in the network configuration register enable the reception of hash matched frames. The destination address is reduced to a 6-bit index into the 64-bit hash register using the following hash function. The hash function is an *exclusive or* of every sixth bit of the destination address.



$$\begin{aligned} \text{hash\_index}[5] &= \text{da}[5] \wedge \text{da}[11] \wedge \text{da}[17] \wedge \text{da}[23] \wedge \text{da}[29] \wedge \text{da}[35] \wedge \text{da}[41] \wedge \text{da}[47] \\ \text{hash\_index}[4] &= \text{da}[4] \wedge \text{da}[10] \wedge \text{da}[16] \wedge \text{da}[22] \wedge \text{da}[28] \wedge \text{da}[34] \wedge \text{da}[40] \wedge \text{da}[46] \\ \text{hash\_index}[3] &= \text{da}[3] \wedge \text{da}[9] \wedge \text{da}[15] \wedge \text{da}[21] \wedge \text{da}[27] \wedge \text{da}[33] \wedge \text{da}[39] \wedge \text{da}[45] \\ \text{hash\_index}[2] &= \text{da}[2] \wedge \text{da}[8] \wedge \text{da}[14] \wedge \text{da}[20] \wedge \text{da}[26] \wedge \text{da}[32] \wedge \text{da}[38] \wedge \text{da}[44] \\ \text{hash\_index}[1] &= \text{da}[1] \wedge \text{da}[7] \wedge \text{da}[13] \wedge \text{da}[19] \wedge \text{da}[25] \wedge \text{da}[31] \wedge \text{da}[37] \wedge \text{da}[43] \\ \text{hash\_index}[0] &= \text{da}[0] \wedge \text{da}[6] \wedge \text{da}[12] \wedge \text{da}[18] \wedge \text{da}[24] \wedge \text{da}[30] \wedge \text{da}[36] \wedge \text{da}[42] \end{aligned}$$

$\text{da}[0]$  represents the least significant bit of the first byte received, that is, the multicast/unicast indicator, and  $\text{da}[47]$  represents the most significant bit of the last byte received.

If the hash index points to a bit that is set in the hash register, then the frame is matched according to whether the frame is multicast or unicast.

A multicast match is signalled if the multicast hash enable bit is set.  $\text{da}[0]$  is 1 and the hash index points to a bit set in the hash register.

A unicast match is signalled if the unicast hash enable bit is set.  $\text{da}[0]$  is 0 and the hash index points to a bit set in the hash register.

To receive all multicast frames, the hash register should be set with all ones and the multicast hash enable bit should be set in the network configuration register.

### 29.5.8 External Address Matching

The external address signal (eam) is enabled by bit 9 in the network configuration register. When enabled, the filter block sends the store frame and the external address match status signal to the DMA block if the external address match signal is asserted (from a source external to the MACB) and the destination address has been received and the frame has not completed.

For the DMA block to be able to copy the frame to memory, the external address signal must be asserted before four words have been loaded into the receive FIFO.

### 29.5.9 Copy All Frames (or Promiscuous Mode)

If the copy all frames bit is set in the network configuration register, then all non-errored frames are copied to memory. For example, frames that are too long, too short, or have FCS errors or  $\text{rx\_er}$  asserted during reception are discarded and all others are received. Frames with FCS errors are copied to memory if bit 19 in the network configuration register is set.

### 29.5.10 Type ID Checking

The contents of the  $\text{type\_id}$  register are compared against the length/type ID of received frames (i.e., bytes 13 and 14). Bit 22 in the receive buffer descriptor status is set if there is a match. The reset state of this register is zero which is unlikely to match the length/type ID of any valid Ethernet frame.

Note: A type ID match does not affect whether a frame is copied to memory.



## 29.5.11 VLAN Support

An Ethernet encoded 802.1Q VLAN tag looks like this:

**Table 29-4.** 802.1Q VLAN Tag

TPID (Tag Protocol Identifier) 16 bits	TCI (Tag Control Information) 16 bits
0x8100	First 3 bits priority, then CFI bit, last 12 bits VID

The VLAN tag is inserted at the 13<sup>th</sup> byte of the frame, adding an extra four bytes to the frame. If the VID (VLAN identifier) is null (0x000), this indicates a priority-tagged frame. The MAC can support frame lengths up to 1536 bytes, 18 bytes more than the original Ethernet maximum frame length of 1518 bytes. This is achieved by setting bit 8 in the network configuration register.

The following bits in the receive buffer descriptor status word give information about VLAN tagged frames:

- Bit 21 set if receive frame is VLAN tagged (i.e. type id of 0x8100)
- Bit 20 set if receive frame is priority tagged (i.e. type id of 0x8100 and null VID). (If bit 20 is set bit 21 is set also.)
- Bit 19, 18 and 17 set to priority if bit 21 is set
- Bit 16 set to CFI if bit 21 is set

## 29.5.12 PHY Maintenance

The register MAN enables the MACB to communicate with a PHY by means of the MDIO interface. It is used during auto-negotiation to ensure that the MACB and the PHY are configured for the same speed and duplex configuration.

The PHY maintenance register is implemented as a shift register. Writing to the register starts a shift operation which is signalled as complete when bit two is set in the network status register (about 2000 MCK cycles later when bit ten is set to zero, and bit eleven is set to one in the network configuration register). An interrupt is generated as this bit is set. During this time, the MSB of the register is output on the MDIO pin and the LSB updated from the MDIO pin with each MDC cycle. This causes transmission of a PHY management frame on MDIO.

Reading during the shift operation returns the current contents of the shift register. At the end of management operation, the bits have shifted back to their original locations. For a read operation, the data bits are updated with data read from the PHY. It is important to write the correct values to the register to ensure a valid PHY management frame is produced.

The MDIO interface can read IEEE 802.3 clause 45 PHYs as well as clause 22 PHYs. To read clause 45 PHYs, bits[31:28] should be written as 0x0011. For a description of MDC generation, see the network configuration register in the ["Network Control Register"](#) on page 456.

## 29.5.13 Media Independent Interface

The Ethernet MAC is capable of interfacing to both RMII and MII Interfaces. The RMII bit in the USRIO register controls the interface that is selected. When this bit is set, the RMII interface is selected, else the MII interface is selected.

The MII and RMII interface are capable of both 10Mb/s and 100Mb/s data rates as described in the IEEE 802.3u standard. The signals used by the MII and RMII interfaces are described in [Table 29-5](#).

**Table 29-5.** Pin Configuration

Pin Name	MII	RMII
ETXCK_EREFC	ETXCK: Transmit Clock	EREFC: Reference Clock
ECRS	ECRS: Carrier Sense	
ECOL	ECOL: Collision Detect	
ERXDV	ERXDV: Data Valid	ECRSDV: Carrier Sense/Data Valid
ERX0 - ERX3	ERX0 - ERX3: 4-bit Receive Data	ERX0 - ERX1: 2-bit Receive Data
ERXER	ERXER: Receive Error	ERXER: Receive Error
ERXCK	ERXCK: Receive Clock	
ETXEN	ETXEN: Transmit Enable	ETXEN: Transmit Enable
ETX0-ETX3	ETX0 - ETX3: 4-bit Transmit Data	ETX0 - ETX1: 2-bit Transmit Data
ETXER	ETXER: Transmit Error	

The intent of the RMII is to provide a reduced pin count alternative to the IEEE 802.3u MII. It uses 2 bits for transmit (ETX0 and ETX1) and two bits for receive (ERX0 and ERX1). There is a Transmit Enable (ETXEN), a Receive Error (ERXER), a Carrier Sense (ECRS\_DV), and a 50 MHz Reference Clock (ETXCK\_EREFC) for 100Mb/s data rate.

### 29.5.13.1 RMII Transmit and Receive Operation

The same signals are used internally for both the RMII and the MII operations. The RMII maps these signals in a more pin-efficient manner. The transmit and receive bits are converted from a 4-bit parallel format to a 2-bit parallel scheme that is clocked at twice the rate. The carrier sense and data valid signals are combined into the ECRSDV signal. This signal contains information on carrier sense, FIFO status, and validity of the data. Transmit error bit (ETXER) and collision detect (ECOL) are not used in RMII mode.

## 29.6 Programming Interface

### 29.6.1 Initialization

#### 29.6.1.1 Configuration

Initialization of the MACB configuration (e.g. frequency ratios) must be done while the transmit and receive circuits are disabled. See the description of the network control register and network configuration register later in this document.

#### 29.6.1.2 Receive Buffer List

Receive data is written to areas of data (i.e., buffers) in system memory. These buffers are listed in another data structure that also resides in main memory. This data structure (receive buffer queue) is a sequence of descriptor entries as defined in ["Receive Buffer Descriptor Entry" on page 440](#). It points to this data structure.

**Figure 29-2.** Receive Buffer List

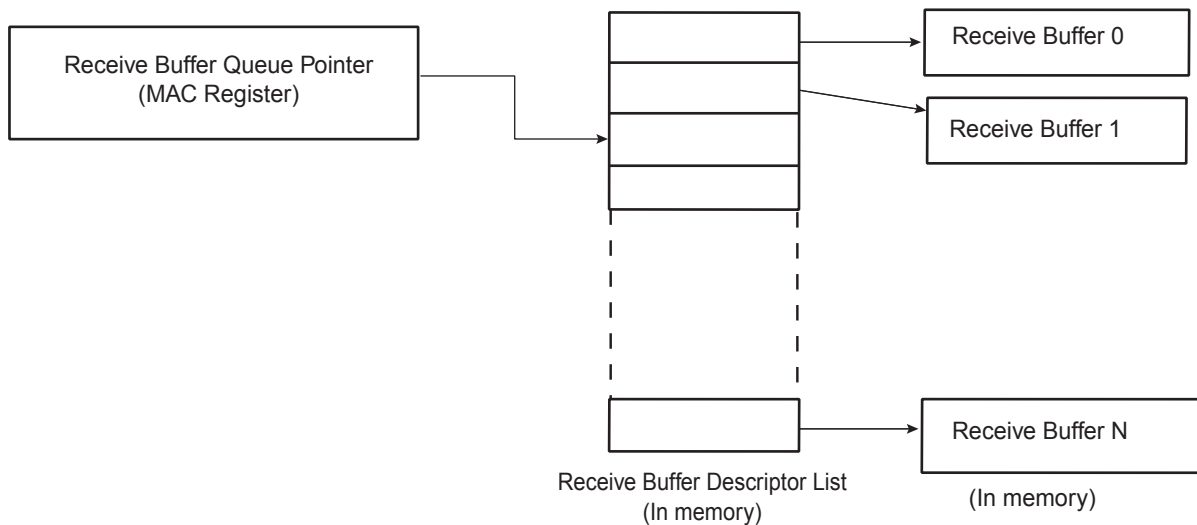

To create the list of buffers:

1. Allocate a number ( $n$ ) of buffers of 128 bytes in system memory.
2. Allocate an area  $2n$  words for the receive buffer descriptor entry in system memory and create  $n$  entries in this list. Mark all entries in this list as owned by MACB, i.e., bit 0 of word 0 set to 0.
3. If less than 1024 buffers are defined, the last descriptor must be marked with the wrap bit (bit 1 in word 0 set to 1).
4. Write address of receive buffer descriptor entry to MACB register receive\_buffer queue pointer.
5. The receive circuits can then be enabled by writing to the address recognition registers and then to the network control register.

### 29.6.1.3 *Transmit Buffer List*

Transmit data is read from the system memory. These buffers are listed in another data structure that also resides in main memory. This data structure (Transmit Buffer Queue) is a sequence of descriptor entries (as defined in [Table 29-2 on page 443](#)) that points to this data structure.

To create this list of buffers:

1. Allocate a number ( $n$ ) of buffers of between 1 and 2047 bytes of data to be transmitted in system memory. Up to 128 buffers per frame are allowed.
2. Allocate an area  $2n$  words for the transmit buffer descriptor entry in system memory and create  $N$  entries in this list. Mark all entries in this list as owned by MACB, i.e. bit 31 of word 1 set to 0.
3. If fewer than 1024 buffers are defined, the last descriptor must be marked with the wrap bit — bit 30 in word 1 set to 1.
4. Write address of transmit buffer descriptor entry to MACB register `transmit_buffer` queue pointer.
5. The transmit circuits can then be enabled by writing to the network control register.

### 29.6.1.4 *Address Matching*

The MACB register-pair hash address and the four specific address register-pairs must be written with the required values. Each register-pair comprises a bottom register and top register, with the bottom register being written first. The address matching is disabled for a particular register-pair after the bottom-register has been written and re-enabled when the top register is written. [See Section “29.5.5” on page 446](#). for details of address matching. Each register-pair may be written at any time, regardless of whether the receive circuits are enabled or disabled.

### 29.6.1.5 *Interrupts*

There are 14 interrupt conditions that are detected within the MACB. These are ORed to make a single interrupt. This interrupt is passed to the interrupt controller. On receipt of the interrupt signal, the CPU enters the interrupt handler. To ascertain which interrupt has been generated, read the interrupt status register. Note that this register clears itself when read. At reset, all interrupts are disabled. To enable an interrupt, write to interrupt enable register with the pertinent interrupt bit set to 1. To disable an interrupt, write to interrupt disable register with the pertinent interrupt bit set to 1. To check whether an interrupt is enabled or disabled, read interrupt mask register: if the bit is set to 1, the interrupt is disabled.

### 29.6.1.6 *Transmitting Frames*

To set up a frame for transmission:

1. Enable transmit in the network control register.
2. Allocate an area of system memory for transmit data. This does not have to be contiguous, varying byte lengths can be used as long as they conclude on byte borders.
3. Set-up the transmit buffer list.
4. Set the network control register to enable transmission and enable interrupts.
5. Write data for transmission into these buffers.
6. Write the address to transmit buffer descriptor queue pointer.
7. Write control and length to word one of the transmit buffer descriptor entry.
8. Write to the transmit start bit in the network control register.

### 29.6.1.7 Receiving Frames

When a frame is received and the receive circuits are enabled, the MACB checks the address and, in the following cases, the frame is written to system memory:

- if it matches one of the four specific address registers.
- if it matches the hash address function.
- if it is a broadcast address (0xFFFFFFFF) and broadcasts are allowed.
- if the MACB is configured to copy all frames.
- if the EAM is asserted before four words have been loaded into the receive FIFO.

The register receive buffer queue pointer points to the next entry (see [Table 29-1 on page 440](#)) and the MACB uses this as the address in system memory to write the frame to. Once the frame has been completely and successfully received and written to system memory, the MACB then updates the receive buffer descriptor entry with the reason for the address match and marks the area as being owned by software. Once this is complete an interrupt receive complete is set. Software is then responsible for handling the data in the buffer and then releasing the buffer by writing the ownership bit back to 0.

If the MACB is unable to write the data at a rate to match the incoming frame, then an interrupt receive overrun is set. If there is no receive buffer available, i.e., the next buffer is still owned by software, the interrupt receive buffer not available is set. If the frame is not successfully received, a statistic register is incremented and the frame is discarded without informing software.

## 29.7 Ethernet MAC (MACB) User Interface

**Table 29-6.** Ethernet MAC (MACB) Register Mapping

Offset	Register	Name	Access	Reset Value
0x00	Network Control Register	NCR	Read/Write	0
0x04	Network Configuration Register	NCFG	Read/Write	0x800
0x08	Network Status Register	NSR	Read-only	-
0x0C	Reserved			
0x10	Reserved			
0x14	Transmit Status Register	TSR	Read/Write	0x0000_0000
0x18	Receive Buffer Queue Pointer Register	RBQP	Read/Write	0x0000_0000
0x1C	Transmit Buffer Queue Pointer Register	TBQP	Read/Write	0x0000_0000
0x20	Receive Status Register	RSR	Read/Write	0x0000_0000
0x24	Interrupt Status Register	ISR	Read/Write	0x0000_0000
0x28	Interrupt Enable Register	IER	Write-only	-
0x2C	Interrupt Disable Register	IDR	Write-only	-
0x30	Interrupt Mask Register	IMR	Read-only	0x0000_3FFF
0x34	Phy Maintenance Register	MAN	Read/Write	0x0000_0000
0x38	Pause Time Register	PTR	Read/Write	0x0000_0000
0x3C	Pause Frames Received Register	PFR	Read/Write	0x0000_0000
0x40	Frames Transmitted Ok Register	FTO	Read/Write	0x0000_0000
0x44	Single Collision Frames Register	SCF	Read/Write	0x0000_0000
0x48	Multiple Collision Frames Register	MCF	Read/Write	0x0000_0000
0x4C	Frames Received Ok Register	FRO	Read/Write	0x0000_0000
0x50	Frame Check Sequence Errors Register	FCSE	Read/Write	0x0000_0000
0x54	Alignment Errors Register	ALE	Read/Write	0x0000_0000
0x58	Deferred Transmission Frames Register	DTF	Read/Write	0x0000_0000
0x5C	Late Collisions Register	LCOL	Read/Write	0x0000_0000
0x60	Excessive Collisions Register	EXCOL	Read/Write	0x0000_0000
0x64	Transmit Underrun Errors Register	TUND	Read/Write	0x0000_0000
0x68	Carrier Sense Errors Register	CSE	Read/Write	0x0000_0000
0x6C	Receive Resource Errors Register	RRE	Read/Write	0x0000_0000
0x70	Receive Overrun Errors Register	ROV	Read/Write	0x0000_0000
0x74	Receive Symbol Errors Register	RSE	Read/Write	0x0000_0000
0x78	Excessive Length Errors Register	ELE	Read/Write	0x0000_0000
0x7C	Receive Jabbers Register	RJA	Read/Write	0x0000_0000
0x80	Undersize Frames Register	USF	Read/Write	0x0000_0000
0x84	SQE Test Errors Register	STE	Read/Write	0x0000_0000
0x88	Received Length Field Mismatch Register	RLE	Read/Write	0x0000_0000

**Table 29-6.** Ethernet MAC (MACB) Register Mapping (Continued)

Offset	Register	Name	Access	Reset Value
0x8C	Transmitted Pause Frames Register	TPF	Read/Write	0x0000_0000
0x90	Hash Register Bottom [31:0] Register	HRB	Read/Write	0x0000_0000
0x94	Hash Register Top [63:32] Register	HRT	Read/Write	0x0000_0000
0x98	Specific Address 1 Bottom Register	SA1B	Read/Write	0x0000_0000
0x9C	Specific Address 1 Top Register	SA1T	Read/Write	0x0000_0000
0xA0	Specific Address 2 Bottom Register	SA2B	Read/Write	0x0000_0000
0xA4	Specific Address 2 Top Register	SA2T	Read/Write	0x0000_0000
0xA8	Specific Address 3 Bottom Register	SA3B	Read/Write	0x0000_0000
0xAC	Specific Address 3 Top Register	SA3T	Read/Write	0x0000_0000
0xB0	Specific Address 4 Bottom Register	SA4B	Read/Write	0x0000_0000
0xB4	Specific Address 4 Top Register	SA4T	Read/Write	0x0000_0000
0xB8	Type ID Checking Register	TID	Read/Write	0x0000_0000
0xBC	Transmit Pause Quantum Register	TPQ	Read/Write	0x0000_FFFF
0xC0	User Input/output Register	USRIO	Read/Write	0x0000_0000
0xC4	Wake on LAN Register	WOL	Read/Write	0x0000_0000
0xC8 - 0xFC	Reserved	–	–	–

## 29.7.1 Network Control Register

**Register Name:** NCR

**Access Type:** Read/Write

31	30	29	28	27	26	25	24
–	–	–	–	–	–	–	–
23	22	21	20	19	18	17	16
–	–	–	–	–	–	–	–
15	14	13	12	11	10	9	8
–	–	–	TZQ	TPF	THALT	TSTART	BP
7	6	5	4	3	2	1	0
WESTAT	INCSTAT	CLRSTAT	MPE	TE	RE	LLB	LB

- **LB: LoopBack**

Asserts the loopback signal to the PHY.

- **LLB: LoopBack Local**

connects txd to rxd, tx\_en to rx\_dv, forces full duplex and drives rx\_clk and tx\_clk with pclk divided by 4. rx\_clk and tx\_clk may glitch as the MACB is switched into and out of internal loop back. It is important that receive and transmit circuits have already been disabled when making the switch into and out of internal loop back. This function may not be supported by some instantiations of the MACB.

- **RE: Receive enable**

When set, enables the MACB to receive data. When reset, frame reception stops immediately and the receive FIFO is cleared. The receive queue pointer register is unaffected.

- **TE: Transmit enable**

When set, enables the Ethernet transmitter to send data. When reset, transmission stops immediately, the transmit FIFO and control registers are cleared and the transmit queue pointer register resets to point to the start of the transmit descriptor list.

- **MPE: Management port enable**

Set to one to enable the management port. When zero, forces MDIO to high impedance state and MDC low.

- **CLRSTAT: Clear statistics registers**

This bit is write only. Writing a one clears the statistics registers.

- **INCSTAT: Increment statistics registers**

This bit is write only. Writing a one increments all the statistics registers by one for test purposes.

- **WESTAT: Write enable for statistics registers**

Setting this bit to one makes the statistics registers writable for functional test purposes.

- **BP: Back pressure**

If set in half duplex mode, forces collisions on all received frames.



- **TSTART: Start transmission**

Writing one to this bit starts transmission.

- **THALT: Transmit halt**

Writing one to this bit halts transmission as soon as any ongoing frame transmission ends.

- **TPF: Transmit pause frame**

Writing one to this bit transmits a pause frame with the pause quantum from the transmit pause quantum register at the next available transmitter idle time.

- **TZQ: Transmit zero quantum pause frame**

Writing a one to this bit transmits a pause frame with zero pause quantum at the next available transmitter idle time.

## 29.7.2 Network Configuration Register

**Register Name:** NCFGR

**Access Type:** Read/Write

31	30	29	28	27	26	25	24
–	–	–	–	–	–	–	–
23	22	21	20	19	18	17	16
–	–	–	–	IRXFCS	EFRHD	DRFCS	RLCE
15	14	13	12	11	10	9	8
RBOF		PAE	RTY	CLK		EAE	BIG
7	6	5	4	3	2	1	0
UNI	MTI	NBC	CAF	JFRAME	Bit rate	FD	SPD

- **SPD: Speed**

Set to 1 to indicate 100 Mbit/s operation, 0 for 10 Mbit/s. The value of this pin is reflected on the `speed` pin.

- **FD: Full Duplex**

If set to 1, the transmit block ignores the state of collision and carrier sense and allows receive while transmitting. Also controls the `half_duplex` pin.

- **Bit rate:**

If set to 1 to configure the interface for serial operation. Must be set before receive and transmit enable in the network control register. If set a serial interface is configured with transmit and receive data being driven out on `txd[0]` and received on `rx_d[0]` serially. Also the `crs` and `rx_dv` are logically ORed together so either may be used as the data valid signal.

- **CAF: Copy All Frames**

When set to 1, all valid frames are received.

- **JFRAME: Jumbo Frames**

Set to one to enable jumbo frames of up to 10240 bytes to be accepted.

- **NBC: No Broadcast**

When set to 1, frames addressed to the broadcast address of all ones are not received.

- **MTI: Multicast Hash Enable**

When set, multicast frames are received when the 6-bit hash function of the destination address points to a bit that is set in the hash register.

- **UNI: Unicast Hash Enable**

When set, unicast frames are received when the 6-bit hash function of the destination address points to a bit that is set in the hash register.

- **BIG: Receive 1536 bytes frames**

Setting this bit means the MACB receives frames up to 1536 bytes in length. Normally, the MACB would reject any frame above 1518 bytes.

- **EAE: External address match enable**

When set, the `eam` pin can be used to copy frames to memory.

- **CLK: MDC clock divider**

Set according to `system clock` speed. This determines by what number `system clock` is divided to generate MDC. For conformance with 802.3, MDC must not exceed 2.5MHz (MDC is only active during MDIO read and write operations).

CLK	MDC
00	MCK divided by 8 (MCK up to 20 MHz)
01	MCK divided by 16 (MCK up to 40 MHz)
10	MCK divided by 32 (MCK up to 80 MHz)
11	MCK divided by 64 (MCK up to 160 MHz)

- **RTY: Retry test**

Must be set to zero for normal operation. If set to one, the back off between collisions is always one slot time. Setting this bit to one helps testing the too many retries condition. Also used in the pause frame tests to reduce the pause counters decrement time from 512 bit times, to every `rx_clk` cycle.

- **PAE: Pause Enable**

When set, transmission pauses when a valid pause frame is received.

- **RBOF: Receive Buffer Offset**

Indicates the number of bytes by which the received data is offset from the start of the first receive buffer.

RBOF	Offset
00	No offset from start of receive buffer
01	One-byte offset from start of receive buffer
10	Two-byte offset from start of receive buffer
11	Three-byte offset from start of receive buffer

- **RLCE: Receive Length field Checking Enable**

When set, frames with measured lengths shorter than their length fields are discarded. Frames containing a type ID in bytes 13 and 14 — length/type ID = 0600 — are not be counted as length errors.

- **DRFCS: Discard Receive FCS**

When set, the FCS field of received frames will not be copied to memory.

- **EFRHD:**

Enable Frames to be received in half-duplex mode while transmitting.

- **IRXFCS: Ignore RX FCS**

When set, frames with FCS/CRC errors are not rejected and no FCS error statistics are counted. For normal operation, this bit must be set to 0.

## 29.7.3 Network Status Register

Register Name: NSR

Access Type: Read-only

31	30	29	28	27	26	25	24
-	-	-	-	-	-	-	-
23	22	21	20	19	18	17	16
-	-	-	-	-	-	-	-
15	14	13	12	11	10	9	8
-	-	-	-	-	-	-	-
7	6	5	4	3	2	1	0
-	-	-	-	-	IDLE	MDIO	-

- **MDIO**

Returns status of the mdio\_in pin. Use the PHY maintenance register for reading managed frames rather than this bit.

- **IDLE**

0 = The PHY logic is running.

1 = The PHY management logic is idle (i.e., has completed).

## 29.7.4 Transmit Status Register

**Register Name:** TSR

**Access Type:** Read/Write

31	30	29	28	27	26	25	24
–	–	–	–	–	–	–	–
23	22	21	20	19	18	17	16
–	–	–	–	–	–	–	–
15	14	13	12	11	10	9	8
–	–	–	–	–	–	–	–
7	6	5	4	3	2	1	0
–	UND	COMP	BEX	TGO	RLE	COL	UBR

This register, when read, provides details of the status of a transmit. Once read, individual bits may be cleared by writing 1 to them. It is not possible to set a bit to 1 by writing to the register.

- **UBR: Used Bit Read**

Set when a transmit buffer descriptor is read with its used bit set. Cleared by writing a one to this bit.

- **COL: Collision Occurred**

Set by the assertion of collision. Cleared by writing a one to this bit.

- **RLE: Retry Limit exceeded**

Cleared by writing a one to this bit.

- **TGO: Transmit Go**

If high transmit is active.

- **BEX: Buffers exhausted mid frame**

If the buffers run out during transmission of a frame, then transmission stops, FCS shall be bad and tx\_er asserted. Cleared by writing a one to this bit.

- **COMP: Transmit Complete**

Set when a frame has been transmitted. Cleared by writing a one to this bit.

- **UND: Transmit Underrun**

Set when transmit DMA was not able to read data from memory, either because the bus was not granted in time, because a not OK hresp (bus error) was returned or because a used bit was read midway through frame transmission. If this occurs, the transmitter forces bad CRC. Cleared by writing a one to this bit.

## 29.7.5 Receive Buffer Queue Pointer Register

**Register Name:** RBQP

**Access Type:** Read/Write

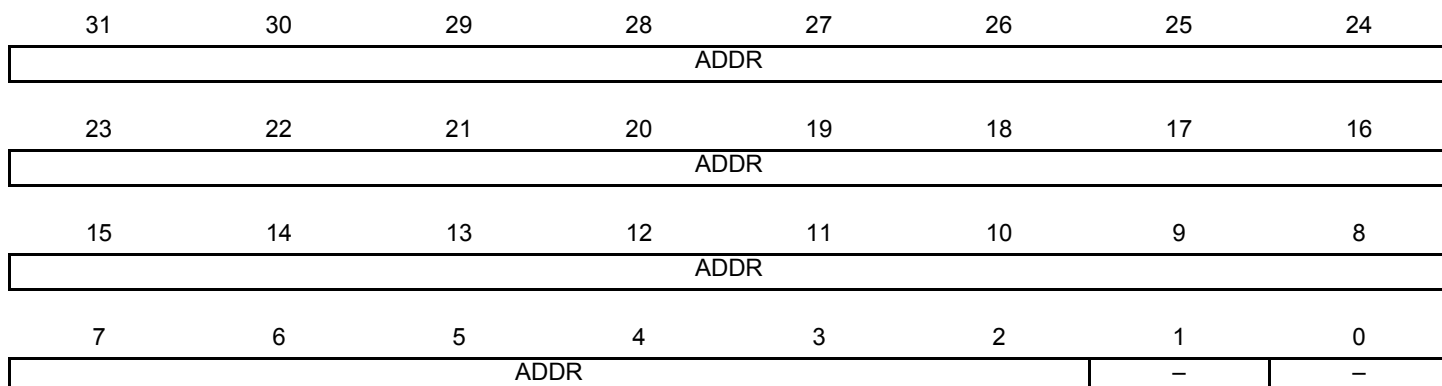

This register points to the entry in the receive buffer queue (descriptor list) currently being used. It is written with the start location of the receive buffer descriptor list. The lower order bits increment as buffers are used up and wrap to their original values after either 1024 buffers or when the wrap bit of the entry is set.

Reading this register returns the location of the descriptor currently being accessed. This value increments as buffers are used. Software should not use this register for determining where to remove received frames from the queue as it constantly changes as new frames are received. Software should instead work its way through the buffer descriptor queue checking the used bits.

Receive buffer writes also comprise bursts of two words and, as with transmit buffer reads, it is recommended that bit 2 is always written with zero to prevent a burst crossing a 1K boundary, in violation of the System Bus specification.

- **ADDR: Receive buffer queue pointer address**

Written with the address of the start of the receive queue, reads as a pointer to the current buffer being used.

## 29.7.6 Transmit Buffer Queue Pointer Register

**Register Name:** TBQP

**Access Type:** Read/Write

31	30	29	28	27	26	25	24
ADDR							
23	22	21	20	19	18	17	16
ADDR							
15	14	13	12	11	10	9	8
ADDR							
7	6	5	4	3	2	1	0
ADDR						-	-

This register points to the entry in the transmit buffer queue (descriptor list) currently being used. It is written with the start location of the transmit buffer descriptor list. The lower order bits increment as buffers are used up and wrap to their original values after either 1024 buffers or when the wrap bit of the entry is set. This register can only be written when bit 3 in the transmit status register is low.

As transmit buffer reads consist of bursts of two words, it is recommended that bit 2 is always written with zero to prevent a burst crossing a 1K boundary, in violation of the System Bus specification.

- **ADDR: Transmit buffer queue pointer address**

Written with the address of the start of the transmit queue, reads as a pointer to the first buffer of the frame being transmitted or about to be transmitted.

## 29.7.7 Receive Status Register

**Register Name:** RSR

**Access Type:** Read/Write

31	30	29	28	27	26	25	24
–	–	–	–	–	–	–	–
23	22	21	20	19	18	17	16
–	–	–	–	–	–	–	–
15	14	13	12	11	10	9	8
–	–	–	–	–	–	–	–
7	6	5	4	3	2	1	0
–	–	–	–	–	OVR	REC	BNA

This register, when read, provides details of the status of a receive. Once read, individual bits may be cleared by writing 1 to them. It is not possible to set a bit to 1 by writing to the register.

- **BNA: Buffer Not Available**

An attempt was made to get a new buffer and the pointer indicated that it was owned by the processor. The DMA rereads the pointer each time a new frame starts until a valid pointer is found. This bit is set at each attempt that fails even if it has not had a successful pointer read since it has been cleared.

Cleared by writing a one to this bit.

- **REC: Frame Received**

One or more frames have been received and placed in memory. Cleared by writing a one to this bit.

- **OVR: Receive Overrun**

The DMA block was unable to store the receive frame to memory, either because the bus was not granted in time or because a not OK `hresp(bus error)` was returned. The buffer is recovered if this happens.

Cleared by writing a one to this bit.



## 29.7.8 Interrupt Status Register

Register Name: ISR

Access Type: Read/Write

31	30	29	28	27	26	25	24
-	-	-	-	-	-	-	-
23	22	21	20	19	18	17	16
-	-	-	-	-	-	-	-
15	14	13	12	11	10	9	8
-	-	PTZ	PFR	HRESP	ROVR	-	-
7	6	5	4	3	2	1	0
TCOMP	TXERR	RLE	TUND	TXUBR	RXUBR	RCOMP	MFD

- **MFD: Management Frame Done**

The PHY maintenance register has completed its operation. Cleared on read.

- **RCOMP: Receive Complete**

A frame has been stored in memory. Cleared on read.

- **RXUBR: Receive Used Bit Read**

Set when a receive buffer descriptor is read with its used bit set. Cleared on read.

- **TXUBR: Transmit Used Bit Read**

Set when a transmit buffer descriptor is read with its used bit set. Cleared on read.

- **TUND: Ethernet Transmit Buffer Underrun**

The transmit DMA did not fetch frame data in time for it to be transmitted or `hresp` returned not OK. Also set if a used bit is read mid-frame or when a new transmit queue pointer is written. Cleared on read.

- **RLE: Retry Limit Exceeded**

Cleared on read.

- **TXERR: Transmit Error**

Transmit buffers exhausted in mid-frame - transmit error. Cleared on read.

- **TCOMP: Transmit Complete**

Set when a frame has been transmitted. Cleared on read.

- **ROVR: Receive Overrun**

Set when the receive overrun status bit gets set. Cleared on read.

- **HRESP: Hresp not OK**

Set when the DMA block sees a `bus error`. Cleared on read.

- **PFR: Pause Frame Received**

Indicates a valid pause has been received. Cleared on a read.

- **PTZ: Pause Time Zero**

Set when the pause time register, 0x38 decrements to zero. Cleared on a read.

### 29.7.9 Interrupt Enable Register

Register Name: IER

**Access Type:** Write-only

31	30	29	28	27	26	25	24
–	–	–	–	–	–	–	–
23	22	21	20	19	18	17	16
–	–	–	–	–	–	–	–
15	14	13	12	11	10	9	8
–	–	PTZ	PFR	HRESP	ROVR		–
7	6	5	4	3	2	1	0
TCOMP	TXERR	RLE	TUND	TXUBR	RXUBR	RCOMP	MFD

- **MFD: Management Frame sent**  
Enable management done interrupt.
- **RCOMP: Receive Complete**  
Enable receive complete interrupt.
- **RXUBR: Receive Used Bit Read**  
Enable receive used bit read interrupt.
- **TXUBR: Transmit Used Bit Read**  
Enable transmit used bit read interrupt.
- **TUND: Ethernet Transmit Buffer Underrun**  
Enable transmit underrun interrupt.
- **RLE: Retry Limit Exceeded**  
Enable retry limit exceeded interrupt.
- **TXERR: Transmit Error**  
Enable transmit buffers exhausted in mid-frame interrupt.
- **TCOMP: Transmit Complete**  
Enable transmit complete interrupt.
- **ROVR: Receive Overrun**  
Enable receive overrun interrupt.
- **HRESP: Hresp not OK**  
Enable Hresp not OK interrupt.
- **PFR: Pause Frame Received**  
Enable pause frame received interrupt.
- **PTZ: Pause Time Zero**  
Enable pause time zero interrupt.

## 29.7.10 Interrupt Disable Register

Register Name: IDR

Access Type: Write-only

31	30	29	28	27	26	25	24
-	-	-	-	-	-	-	-
23	22	21	20	19	18	17	16
-	-	-	-	-	-	-	-
15	14	13	12	11	10	9	8
-	-	PTZ	PFR	HRESP	ROVR	-	-
7	6	5	4	3	2	1	0
TCOMP	TXERR	RLE	TUND	TXUBR	RXUBR	RCOMP	MFD

- MFD: Management Frame sent**  
 Disable management done interrupt.
- RCOMP: Receive Complete**  
 Disable receive complete interrupt.
- RXUBR: Receive Used Bit Read**  
 Disable receive used bit read interrupt.
- TXUBR: Transmit Used Bit Read**  
 Disable transmit used bit read interrupt.
- TUND: Ethernet Transmit Buffer Underrun**  
 Disable transmit underrun interrupt.
- RLE: Retry Limit Exceeded**  
 Disable retry limit exceeded interrupt.
- TXERR: Transmit Error**  
 Disable transmit buffers exhausted in mid-frame interrupt.
- TCOMP: Transmit Complete**  
 Disable transmit complete interrupt.
- ROVR: Receive Overrun**  
 Disable receive overrun interrupt.
- HRESP: Hresp not OK**  
 Disable Hresp not OK interrupt.
- PFR: Pause Frame Received**  
 Disable pause frame received interrupt.
- PTZ: Pause Time Zero**  
 Disable pause time zero interrupt.



## 29.7.11 Interrupt Mask Register

**Register Name:** IMR

**Access Type:** Write-only

31	30	29	28	27	26	25	24
-	-	-	-	-	-	-	-
23	22	21	20	19	18	17	16
-	-	-	-	-	-	-	-
15	14	13	12	11	10	9	8
-	-	PTZ	PFR	HRESP	ROVR	-	-
7	6	5	4	3	2	1	0
TCOMP	TXERR	RLE	TUND	TXUBR	RXUBR	RCOMP	MFD

- **MFD: Management Frame sent**  
Management done interrupt masked.
- **RCOMP: Receive Complete**  
Receive complete interrupt masked.
- **RXUBR: Receive Used Bit Read**  
Receive used bit read interrupt masked.
- **TXUBR: Transmit Used Bit Read**  
Transmit used bit read interrupt masked.
- **TUND: Ethernet Transmit Buffer Underrun**  
Transmit underrun interrupt masked.
- **RLE: Retry Limit Exceeded**  
Retry limit exceeded interrupt masked.
- **TXERR: Transmit Error**  
Transmit buffers exhausted in mid-frame interrupt masked.
- **TCOMP: Transmit Complete**  
Transmit complete interrupt masked.
- **ROVR: Receive Overrun**  
Receive overrun interrupt masked.
- **HRESP: Hresp not OK**  
Hresp not OK interrupt masked.
- **PFR: Pause Frame Received**  
Pause frame received interrupt masked.
- **PTZ: Pause Time Zero**  
Pause time zero interrupt masked.



## 29.7.12 PHY Maintenance Register

**Register Name:** MAN

**Access Type:** Read/Write

31	30	29	28	27	26	25	24
SOF		RW		PHYA			
23	22	21	20	19	18	17	16
PHYA	REGA					CODE	
15	14	13	12	11	10	9	8
DATA							
7	6	5	4	3	2	1	0
DATA							

- **DATA**

For a write operation this is written with the data to be written to the PHY.

After a read operation this contains the data read from the PHY.

- **CODE:**

Must be written to 10. Reads as written.

- **REGA: Register Address**

Specifies the register in the PHY to access.

- **PHYA: PHY Address**

- **RW: Read/Write**

10 is read; 01 is write. Any other value is an invalid PHY management frame

- **SOF: Start of frame**

Must be written 01 for a valid frame.

## 29.7.13 Pause Time Register

**Register Name:** PTR

**Access Type:** Read/Write

31	30	29	28	27	26	25	24
–	–	–	–	–	–	–	–
23	22	21	20	19	18	17	16
–	–	–	–	–	–	–	–
15	14	13	12	11	10	9	8
PTIME							
7	6	5	4	3	2	1	0
PTIME							

- **PTIME: Pause Time**

Stores the current value of the pause time register which is decremented every 512 bit times.

**29.7.14 Hash Register Bottom**

**Register Name:** HRB

**Access Type:** Read/Write

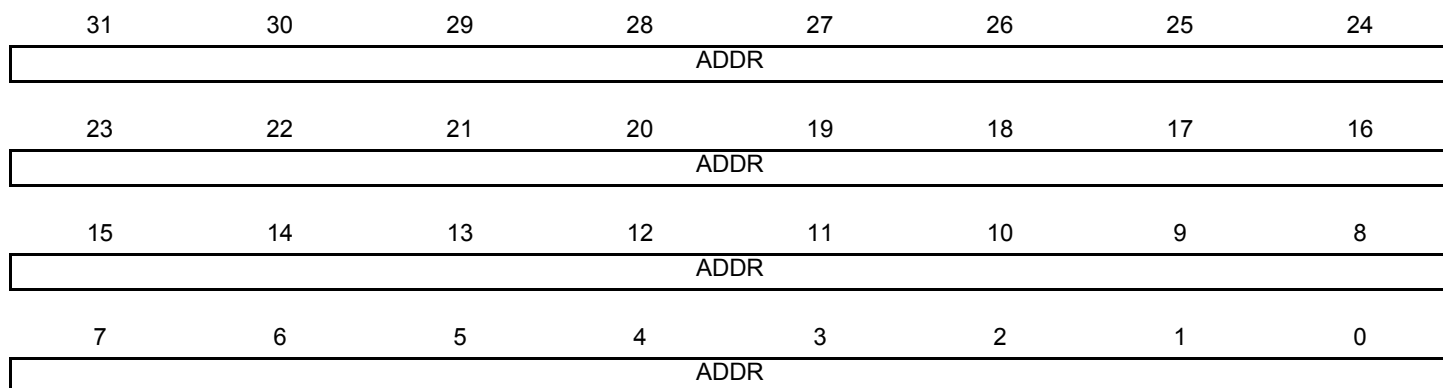

- **ADDR:**

Bits 31:0 of the hash address register. See ["Hash Addressing"](#) on page 447.



**29.7.15 Hash Register Top**

**Register Name:** HRT

**Access Type:** Read/Write

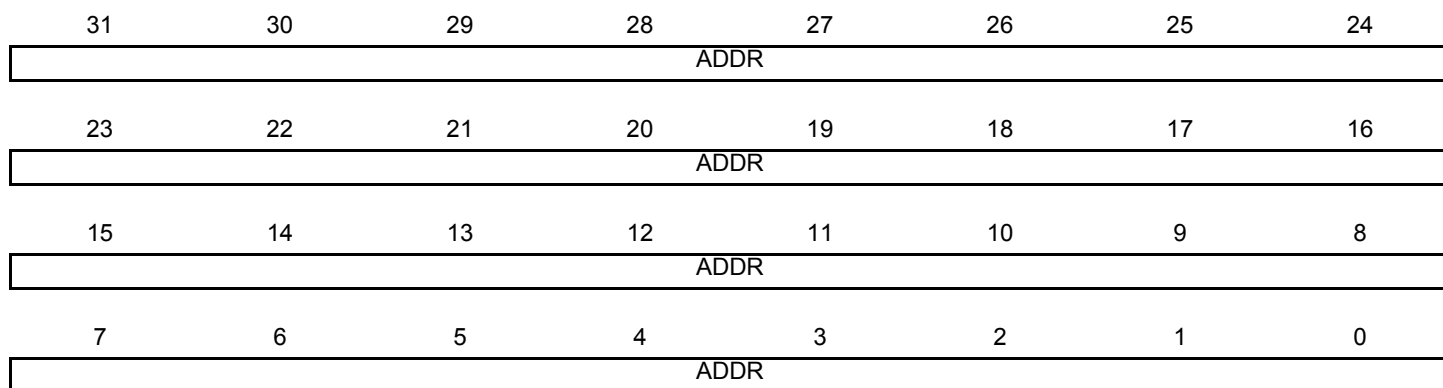

- **ADDR:**

Bits 63:32 of the hash address register. See ["Hash Addressing" on page 447](#).

**29.7.16 Specific Address 1 Bottom Register**

**Register Name:** SA1B

**Access Type:** Read/Write

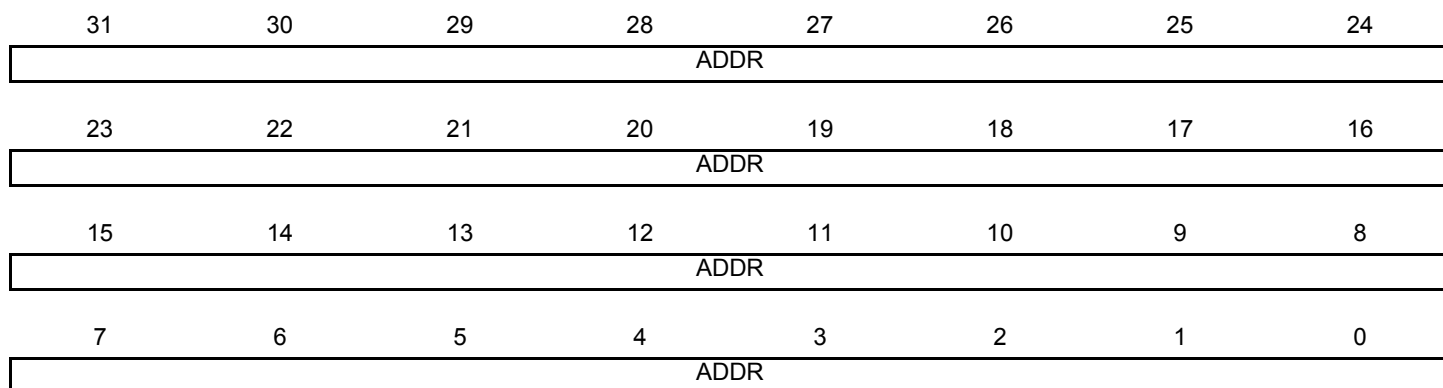

• **ADDR**

Least significant bits of the destination address. Bit zero indicates whether the address is multicast or unicast and corresponds to the least significant bit of the first byte received.

**29.7.17 Specific Address 1 Top Register**

Register Name: SA1T

Access Type: Read/Write

31	30	29	28	27	26	25	24
-	-	-	-	-	-	-	-
23	22	21	20	19	18	17	16
-	-	-	-	-	-	-	-
15	14	13	12	11	10	9	8
ADDR							
7	6	5	4	3	2	1	0
ADDR							

• **ADDR**

The most significant bits of the destination address, that is bits 47 to 32.

## 29.7.18 Specific Address 2 Bottom Register

**Register Name:** SA2B

**Access Type:** Read/Write

31	30	29	28	27	26	25	24
ADDR							
23	22	21	20	19	18	17	16
ADDR							
15	14	13	12	11	10	9	8
ADDR							
7	6	5	4	3	2	1	0
ADDR							

- **ADDR**

Least significant bits of the destination address. Bit zero indicates whether the address is multicast or unicast and corresponds to the least significant bit of the first byte received.

**29.7.19 Specific Address 2 Top Register**

Register Name: SA2T

Access Type: Read/Write

31	30	29	28	27	26	25	24
–	–	–	–	–	–	–	–
23	22	21	20	19	18	17	16
–	–	–	–	–	–	–	–
15	14	13	12	11	10	9	8
ADDR							
7	6	5	4	3	2	1	0
ADDR							

• **ADDR**

The most significant bits of the destination address, that is bits 47 to 32.

## 29.7.20 Specific Address 3 Bottom Register

**Register Name:** SA3B

**Access Type:** Read/Write

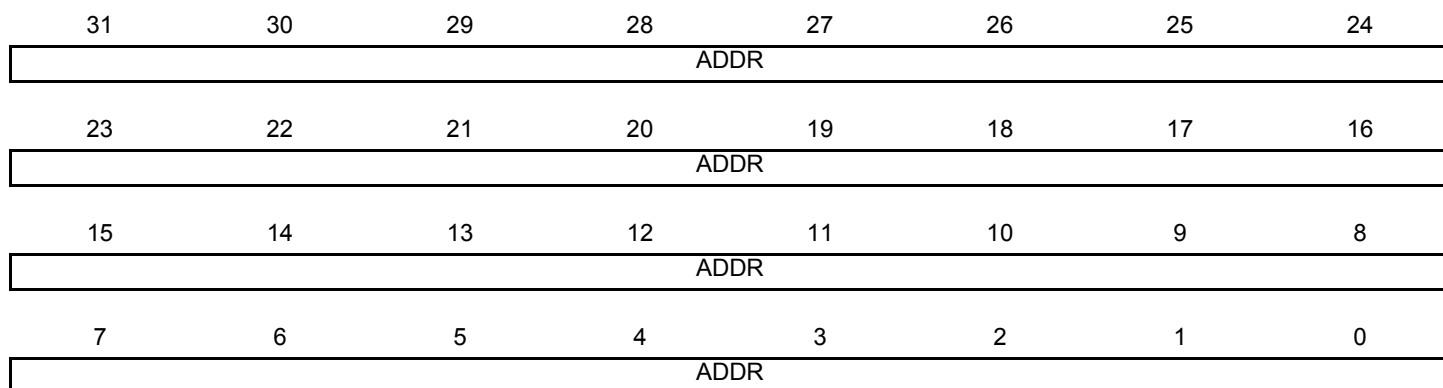

- **ADDR**

Least significant bits of the destination address. Bit zero indicates whether the address is multicast or unicast and corresponds to the least significant bit of the first byte received.

**29.7.21 Specific Address 3 Top Register**

Register Name: SA3T

Access Type: Read/Write

31	30	29	28	27	26	25	24
-	-	-	-	-	-	-	-
23	22	21	20	19	18	17	16
-	-	-	-	-	-	-	-
15	14	13	12	11	10	9	8
ADDR							
7	6	5	4	3	2	1	0
ADDR							

• **ADDR**

The most significant bits of the destination address, that is bits 47 to 32.

**29.7.22 Specific Address 4 Bottom Register**

**Register Name:** SA4B

**Access Type:** Read/Write

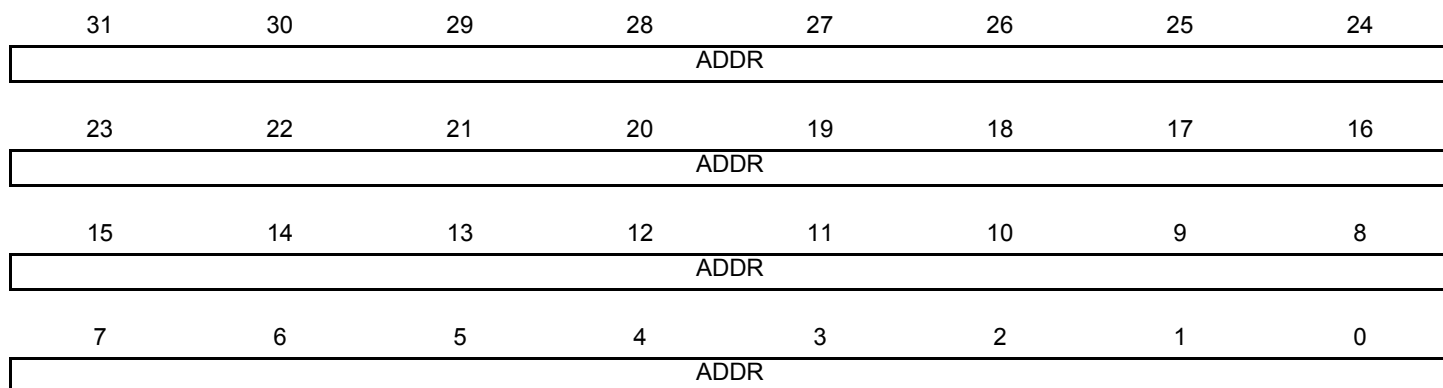

• **ADDR**

Least significant bits of the destination address. Bit zero indicates whether the address is multicast or unicast and corresponds to the least significant bit of the first byte received.



**29.7.23 Specific Address 4 Top Register**

Register Name: SA4T

Access Type: Read/Write

31	30	29	28	27	26	25	24
-	-	-	-	-	-	-	-
23	22	21	20	19	18	17	16
-	-	-	-	-	-	-	-
15	14	13	12	11	10	9	8
ADDR							
7	6	5	4	3	2	1	0
ADDR							

• **ADDR**

The most significant bits of the destination address, that is bits 47 to 32.

**29.7.24 Type ID Checking Register**

**Register Name:** TID

**Access Type:** Read/Write

31	30	29	28	27	26	25	24
-	-	-	-	-	-	-	-
23	22	21	20	19	18	17	16
-	-	-	-	-	-	-	-
15	14	13	12	11	10	9	8
TID							
7	6	5	4	3	2	1	0
TID							

- **TID: Type ID checking**

For use in comparisons with received frames TypeID/Length field.

## 29.7.25 Transmit Pause Quantum Register

**Register Name:** TPQ

**Access Type:** Read/Write

31	30	29	28	27	26	25	24
–	–	–	–	–	–	–	–
23	22	21	20	19	18	17	16
–	–	–	–	–	–	–	–
15	14	13	12	11	10	9	8
TPQ							
7	6	5	4	3	2	1	0
TPQ							

- **TPQ: Transmit Pause Quantum**

Used in hardware generation of transmitted pause frames as value for pause quantum.

## 29.7.26 User Input/Output Register

**Register Name:** USRIO

**Access Type:** Read/Write

31	30	29	28	27	26	25	24
–	–	–	–	–	–	–	–
23	22	21	20	19	18	17	16
–	–	–	–	–	–	–	–
15	14	13	12	11	10	9	8
–	–	–	–	–	–	–	–
7	6	5	4	3	2	1	0
–	–	–	–	TX_PAUSE_ZERO	TX_PAUSE	EAM	RMII

- **RMII**

When set, this bit enables the MII operation mode. When reset, it selects the RMII mode.

- **EAM**

When set, this bit causes a frame to be copied to memory, if this feature is enabled by the EAE bit in NCFGR. Otherwise, no frame is copied.

- **TX\_PAUSE**

toggling this bit causes a PAUSE frame to be transmitted.

- **TX\_PAUSE\_ZERO**

Selects either zero or the transmit quantum register as the transmitted pause frame quantum.

## 29.7.27 Wake-on-LAN Register

Register Name: WOL

Access Type: Read/Write

31	30	29	28	27	26	25	24
–	–	–	–	–	–	–	–
23	22	21	20	19	18	17	16
–	–	–	–	MTI	SA1	ARP	MAG
15	14	13	12	11	10	9	8
IP							
7	6	5	4	3	2	1	0
IP							

- **IP: ARP request IP address**

Written to define the least significant 16 bits of the target IP address that is matched to generate a Wake-on-LAN event. A value of zero does not generate an event, even if this is matched by the received frame.

- **MAG: Magic packet event enable**

When set, magic packet events causes the `wol` output to be asserted.

- **ARP: ARP request event enable**

When set, ARP request events causes the `wol` output to be asserted.

- **SA1: Specific address register 1 event enable**

When set, specific address 1 events causes the `wol` output to be asserted.

- **MTI: Multicast hash event enable**

When set, multicast hash events causes the `wol` output to be asserted.

## 29.7.28 MACB Statistic Registers

These registers reset to zero on a read and stick at all ones when they count to their maximum value. They should be read frequently enough to prevent loss of data. The receive statistics registers are only incremented when the receive enable bit is set in the network control register. To write to these registers, bit 7, WESTAT, in the network control register, NCR, must be set. The statistics register block contains the following registers.

### 29.7.28.1 Pause Frames Received Register

**Register Name:** PFR

**Access Type:** Read/Write

31	30	29	28	27	26	25	24
–	–	–	–	–	–	–	–
23	22	21	20	19	18	17	16
–	–	–	–	–	–	–	–
15	14	13	12	11	10	9	8
FROK							
7	6	5	4	3	2	1	0
FROK							

- **FROK: Pause Frames received OK**

A 16-bit register counting the number of good pause frames received. A good frame has a length of 64 to 1518 (1536 if bit 8, BIG, in network configuration register, NCFGR, is set, 10240 if bit 3, JFRAME in network configuration register, NCFGR, is set) and has no FCS, alignment or receive symbol errors.

### 29.7.28.2 Frames Transmitted OK Register

**Register Name:** FTO

**Access Type:** Read/Write

31	30	29	28	27	26	25	24
–	–	–	–	–	–	–	–
23	22	21	20	19	18	17	16
FTOK							
15	14	13	12	11	10	9	8
FTOK							
7	6	5	4	3	2	1	0
FTOK							

- **FTOK: Frames Transmitted OK**

A 24-bit register counting the number of frames successfully transmitted, i.e., no underrun and not too many retries.

### 29.7.28.3 Single Collision Frames Register

**Register Name:** SCF

**Access Type:** Read/Write

31	30	29	28	27	26	25	24
–	–	–	–	–	–	–	–
23	22	21	20	19	18	17	16
–	–	–	–	–	–	–	–
15	14	13	12	11	10	9	8
SCF							
7	6	5	4	3	2	1	0
SCF							

- **SCF: Single Collision Frames**

A 16-bit register counting the number of frames experiencing a single collision before being successfully transmitted, i.e., no underrun.

### 29.7.28.4 Multicollision Frames Register

**Register Name:** MCF

**Access Type:** Read/Write

31	30	29	28	27	26	25	24
–	–	–	–	–	–	–	–
23	22	21	20	19	18	17	16
–	–	–	–	–	–	–	–
15	14	13	12	11	10	9	8
MCF							
7	6	5	4	3	2	1	0
MCF							

- **MCF: Multicollision Frames**

A 16-bit register counting the number of frames experiencing between two and fifteen collisions prior to being successfully transmitted, i.e., no underrun and not too many retries.

## 29.7.28.5 Frames Received OK Register

**Register Name:** FRO

**Access Type:** Read/Write

31	30	29	28	27	26	25	24
–	–	–	–	–	–	–	–
23	22	21	20	19	18	17	16
FROK							
15	14	13	12	11	10	9	8
FROK							
7	6	5	4	3	2	1	0
FROK							

- **FROK: Frames Received OK**

A 24-bit register counting the number of good frames received, i.e., address recognized and successfully copied to memory. A good frame is of length 64 to 1518 bytes (1536 if bit 8, BIG, in network configuration register, NCFGR, is set, 10240 if bit 3, JFRAME in network configuration register, NCFGR, is set) and has no FCS, alignment or receive symbol errors.

## 29.7.28.6 Frames Check Sequence Errors Register

**Register Name:** FCSE

**Access Type:** Read/Write

31	30	29	28	27	26	25	24
–	–	–	–	–	–	–	–
23	22	21	20	19	18	17	16
–	–	–	–	–	–	–	–
15	14	13	12	11	10	9	8
–	–	–	–	–	–	–	–
7	6	5	4	3	2	1	0
FCSE							

- **FCSE: Frame Check Sequence Errors**

An 8-bit register counting frames that are an integral number of bytes, have bad CRC and are between 64 and 1518 bytes in length (1536 if bit 8, BIG, in network configuration register, NCFGR, is set, 10240 if bit 3, JFRAME in network configuration register, NCFGR, is set). This register is also incremented if a symbol error is detected and the frame is of valid length and has an integral number of bytes.



## 29.7.28.7 Alignment Errors Register

**Register Name:** ALE

**Access Type:** Read/Write

31	30	29	28	27	26	25	24
–	–	–	–	–	–	–	–
23	22	21	20	19	18	17	16
–	–	–	–	–	–	–	–
15	14	13	12	11	10	9	8
–	–	–	–	–	–	–	–
7	6	5	4	3	2	1	0
ALE							

- ALE: Alignment Errors**

An 8-bit register counting frames that are not an integral number of bytes long and have bad CRC when their length is truncated to an integral number of bytes and are between 64 and 1518 bytes in length (1536 if bit 8, BIG, in network configuration register, NCFGR, is set, 10240 if bit 3, JFRAME in network configuration register, NCFGR, is set). This register is also incremented if a symbol error is detected and the frame is of valid length and does not have an integral number of bytes.

## 29.7.28.8 Deferred Transmission Frames Register

**Register Name:** DTF

**Access Type:** Read/Write

31	30	29	28	27	26	25	24
–	–	–	–	–	–	–	–
23	22	21	20	19	18	17	16
–	–	–	–	–	–	–	–
15	14	13	12	11	10	9	8
DTF							
7	6	5	4	3	2	1	0
DTF							

- DTF: Deferred Transmission Frames**

A 16-bit register counting the number of frames experiencing deferral due to carrier sense being active on their first attempt at transmission. Frames involved in any collision are not counted nor are frames that experienced a transmit underrun.

## 29.7.28.9 Late Collisions Register

**Register Name:** LCOL

**Access Type:** Read/Write

31	30	29	28	27	26	25	24
–	–	–	–	–	–	–	–
23	22	21	20	19	18	17	16
–	–	–	–	–	–	–	–
15	14	13	12	11	10	9	8
–	–	–	–	–	–	–	–
7	6	5	4	3	2	1	0
LCOL							

- **LCOL: Late Collisions**

An 8-bit register counting the number of frames that experience a collision after the slot time (512 bits) has expired. A late collision is counted twice; i.e., both as a collision and a late collision.

## 29.7.28.10 Excessive Collisions Register

**Register Name:** EXCOL

**Access Type:** Read/Write

31	30	29	28	27	26	25	24
–	–	–	–	–	–	–	–
23	22	21	20	19	18	17	16
–	–	–	–	–	–	–	–
15	14	13	12	11	10	9	8
–	–	–	–	–	–	–	–
7	6	5	4	3	2	1	0
EXCOL							

- **EXCOL: Excessive Collisions**

An 8-bit register counting the number of frames that failed to be transmitted because they experienced 16 collisions.

## 29.7.28.11 Transmit Underrun Errors Register

**Register Name:** TUND

**Access Type:** Read/Write

31	30	29	28	27	26	25	24
–	–	–	–	–	–	–	–
23	22	21	20	19	18	17	16
–	–	–	–	–	–	–	–
15	14	13	12	11	10	9	8
–	–	–	–	–	–	–	–
7	6	5	4	3	2	1	0
TUND							

- **TUND: Transmit Underruns**

An 8-bit register counting the number of frames not transmitted due to a transmit DMA underrun. If this register is incremented, then no other statistics register is incremented.

## 29.7.28.12 Carrier Sense Errors Register

**Register Name:** CSE

**Access Type:** Read/Write

31	30	29	28	27	26	25	24
–	–	–	–	–	–	–	–
23	22	21	20	19	18	17	16
–	–	–	–	–	–	–	–
15	14	13	12	11	10	9	8
–	–	–	–	–	–	–	–
7	6	5	4	3	2	1	0
CSE							

- **CSE: Carrier Sense Errors**

An 8-bit register counting the number of frames transmitted where carrier sense was not seen during transmission or where carrier sense was deasserted after being asserted in a transmit frame without collision (no underrun). Only incremented in half-duplex mode. The only effect of a carrier sense error is to increment this register. The behavior of the other statistics registers is unaffected by the detection of a carrier sense error.

## 29.7.28.13 Receive Resource Errors Register

**Register Name:** RRE

**Access Type:** Read/Write

31	30	29	28	27	26	25	24
–	–	–	–	–	–	–	–
23	22	21	20	19	18	17	16
–	–	–	–	–	–	–	–
15	14	13	12	11	10	9	8
RRE							
7	6	5	4	3	2	1	0
RRE							

- **RRE: Receive Resource Errors**

A 16-bit register counting the number of frames that were address matched but could not be copied to memory because no receive buffer was available.

## 29.7.28.14 Receive Overrun Errors Register

**Register Name:** ROVR

**Access Type:** Read/Write

31	30	29	28	27	26	25	24
–	–	–	–	–	–	–	–
23	22	21	20	19	18	17	16
–	–	–	–	–	–	–	–
15	14	13	12	11	10	9	8
–	–	–	–	–	–	–	–
7	6	5	4	3	2	1	0
ROVR							

- **ROVR: Receive Overrun**

An 8-bit register counting the number of frames that are address recognized but were not copied to memory due to a receive DMA overrun.

## 29.7.28.15 Receive Symbol Errors Register

**Register Name:** RSE

**Access Type:** Read/Write

31	30	29	28	27	26	25	24
–	–	–	–	–	–	–	–
23	22	21	20	19	18	17	16
–	–	–	–	–	–	–	–
15	14	13	12	11	10	9	8
–	–	–	–	–	–	–	–
7	6	5	4	3	2	1	0
RSE							

- **RSE: Receive Symbol Errors**

An 8-bit register counting the number of frames that had `rx_er` asserted during reception. Receive symbol errors are also counted as an FCS or alignment error if the frame is between 64 and 1518 bytes in length (1536 if bit 8, `BIG`, in network configuration register, `NCFGR`, is set, 10240 if bit 3, `JFRAME` in network configuration register, `NCFGR`, is set). If the frame is larger, it is recorded as a jabber error.

## 29.7.28.16 Excessive Length Errors Register

**Register Name:** ELE

**Access Type:** Read/Write

31	30	29	28	27	26	25	24
–	–	–	–	–	–	–	–
23	22	21	20	19	18	17	16
–	–	–	–	–	–	–	–
15	14	13	12	11	10	9	8
–	–	–	–	–	–	–	–
7	6	5	4	3	2	1	0
EXL							

- **EXL: Excessive Length Errors**

An 8-bit register counting the number of frames received exceeding 1518 bytes (1536 if bit 8, `BIG`, in network configuration register, `NCFGR`, is set, 10240 if bit 3, `JFRAME` in network configuration register, `NCFGR`, is set) in length but do not have either a CRC error, an alignment error nor a receive symbol error.

## 29.7.28.17 Receive Jabbers Register

**Register Name:** RJA

**Access Type:** Read/Write

31	30	29	28	27	26	25	24
–	–	–	–	–	–	–	–
23	22	21	20	19	18	17	16
–	–	–	–	–	–	–	–
15	14	13	12	11	10	9	8
–	–	–	–	–	–	–	–
7	6	5	4	3	2	1	0
RJB							

- **RJB: Receive Jabbers**

An 8-bit register counting the number of frames received exceeding 1518 bytes (1536 if bit 8, BIG, in network configuration register, NCFGR, is set, 10240 if bit 3, JFRAME in network configuration register, NCFGR, is set) in length and have either a CRC error, an alignment error or a receive symbol error.

## 29.7.28.18 Undersize Frames Register

**Register Name:** USF

**Access Type:** Read/Write

31	30	29	28	27	26	25	24
–	–	–	–	–	–	–	–
23	22	21	20	19	18	17	16
–	–	–	–	–	–	–	–
15	14	13	12	11	10	9	8
–	–	–	–	–	–	–	–
7	6	5	4	3	2	1	0
USF							

- **USF: Undersize frames**

An 8-bit register counting the number of frames received less than 64 bytes in length but do not have either a CRC error, an alignment error or a receive symbol error.

## 29.7.28.19 SQE Test Errors Register

**Register Name:** STE

**Access Type:** Read/Write

31	30	29	28	27	26	25	24
–	–	–	–	–	–	–	–
23	22	21	20	19	18	17	16
–	–	–	–	–	–	–	–
15	14	13	12	11	10	9	8
–	–	–	–	–	–	–	–
7	6	5	4	3	2	1	0
SQER							

- **SQER: SQE test errors**

An 8-bit register counting the number of frames where `col` was not asserted within 96 bit times (an interframe gap) of `tx_en` being deasserted in half duplex mode.

## 29.7.28.20 Received Length Field Mismatch Register

**Register Name:** RLE

**Access Type:** Read/Write

31	30	29	28	27	26	25	24
–	–	–	–	–	–	–	–
23	22	21	20	19	18	17	16
–	–	–	–	–	–	–	–
15	14	13	12	11	10	9	8
–	–	–	–	–	–	–	–
7	6	5	4	3	2	1	0
RLFM							

- **RLFM: Receive Length Field Mismatch**

An 8-bit register counting the number of frames received that have a measured length shorter than that extracted from its length field. Checking is enabled through bit 16 of the network configuration register. Frames containing a type ID in bytes 13 and 14 (i.e., length/type ID  $\neq$  0x0600) are not counted as length field errors, neither are excessive length frames.

## 29.7.28.21 Transmitted Pause Frames Register

**Register Name:** TPF

**Access Type:** Read/Write

31	30	29	28	27	26	25	24
–	–	–	–	–	–	–	–
23	22	21	20	19	18	17	16
–	–	–	–	–	–	–	–
15	14	13	12	11	10	9	8
TPF							
7	6	5	4	3	2	1	0
TPF							

- **TPF: Transmitted Pause Frames**

A 16-bit register counting the number of pause frames transmitted.



## 30. USB On-The-Go Interface (USBB)

Rev: 3.1.1.1

### 30.1 Features

- **USB 2.0 Compliant, Full-/Low-Speed (FS/LS) and On-The-Go (OTG), 12 Mbit/s**
- **7 Pipes/Endpoints**
- **960 bytes of Embedded Dual-Port RAM (DPRAM) for Pipes/Endpoints**
- **Up to 2 Memory Banks per Pipe/Endpoint (Not for Control Pipe/Endpoint)**
- **Flexible Pipe/Endpoint Configuration and Management with Dedicated DMA Channels**
- **On-Chip Transceivers Including Pull-Ups/Pull-downs.**
- **On-Chip OTG pad including VBUS analog comparator**

### 30.2 Description

The Universal Serial Bus (USB) MCU device complies with the Universal Serial Bus (USB) 2.0 specification, but it does NOT feature high-speed USB (480 Mbit/s).

Each pipe/endpoint can be configured in one of several transfer types. It can be associated with one or more banks of a dual-port RAM used to store the current data payload. If several banks are used (“ping-pong” mode), then one DPRAM bank is read or written by the CPU or the DMA while the other is read or written by the USB macro core. This feature is mandatory for isochronous pipes/endpoints.

[Table 30-1](#) describes the hardware configuration of the USB MCU device.

**Table 30-1.** Description of USB Pipes/Endpoints

Pipe/Endpoint	Mnemonic	Max. Size	Max. Nb. Banks	DMA	Type
0	PEP0	64 bytes	1	N	Control
1	PEP1	bytes		Y	Isochronous/Bulk/Interrupt
2	PEP2	bytes		Y	Isochronous/Bulk/Interrupt
3	PEP3	64 bytes		Y	Bulk/Interrupt
4	PEP4	64 bytes		Y	Bulk/Interrupt
5	PEP5	bytes		Y	Isochronous/Bulk/Interrupt
6	PEP6	bytes		Y	Isochronous/Bulk/Interrupt

The theoretical maximal pipe/endpoint configuration (1600 bytes) exceeds the real DPRAM size (960 bytes). The user needs to be aware of this when configuring pipes/endpoints. To fully use the 960 bytes of DPRAM, the user could for example use the configuration described in [Table 30-2](#).

**Table 30-2.** Example of Configuration of Pipes/Endpoints Using the Whole DPRAM

Pipe/Endpoint	Mnemonic	Size	Nb. Banks
0	PEP0	64 bytes	1
1	PEP1	64 bytes	2
2	PEP2	64 bytes	2
3	PEP3	64 bytes	1

**Table 30-2.** Example of Configuration of Pipes/Endpoints Using the Whole DPRAM

Pipe/Endpoint	Mnemonic	Size	Nb. Banks
4	PEP4	64 bytes	1
5	PEP5	256 bytes	1
6	PEP6	256 bytes	1

### 30.3 Block Diagram

The USB controller provides a hardware device to interface a USB link to a data flow stored in a dual-port RAM (DPRAM).

The USB controller requires a 48 MHz  $\pm$  0.25% reference clock, which is the USB generic clock generated from one of the power manager oscillators, optionally through one of the power manager PLLs.

The 48 MHz clock is used to generate a 12 MHz full-speed (or 1.5 MHz low-speed) bit clock from the received USB differential data and to transmit data according to full- or low-speed USB device tolerance. Clock recovery is achieved by a digital phase-locked loop (a DPLL, not represented), which complies with the USB jitter specifications.

Figure 30-1. Block Diagram

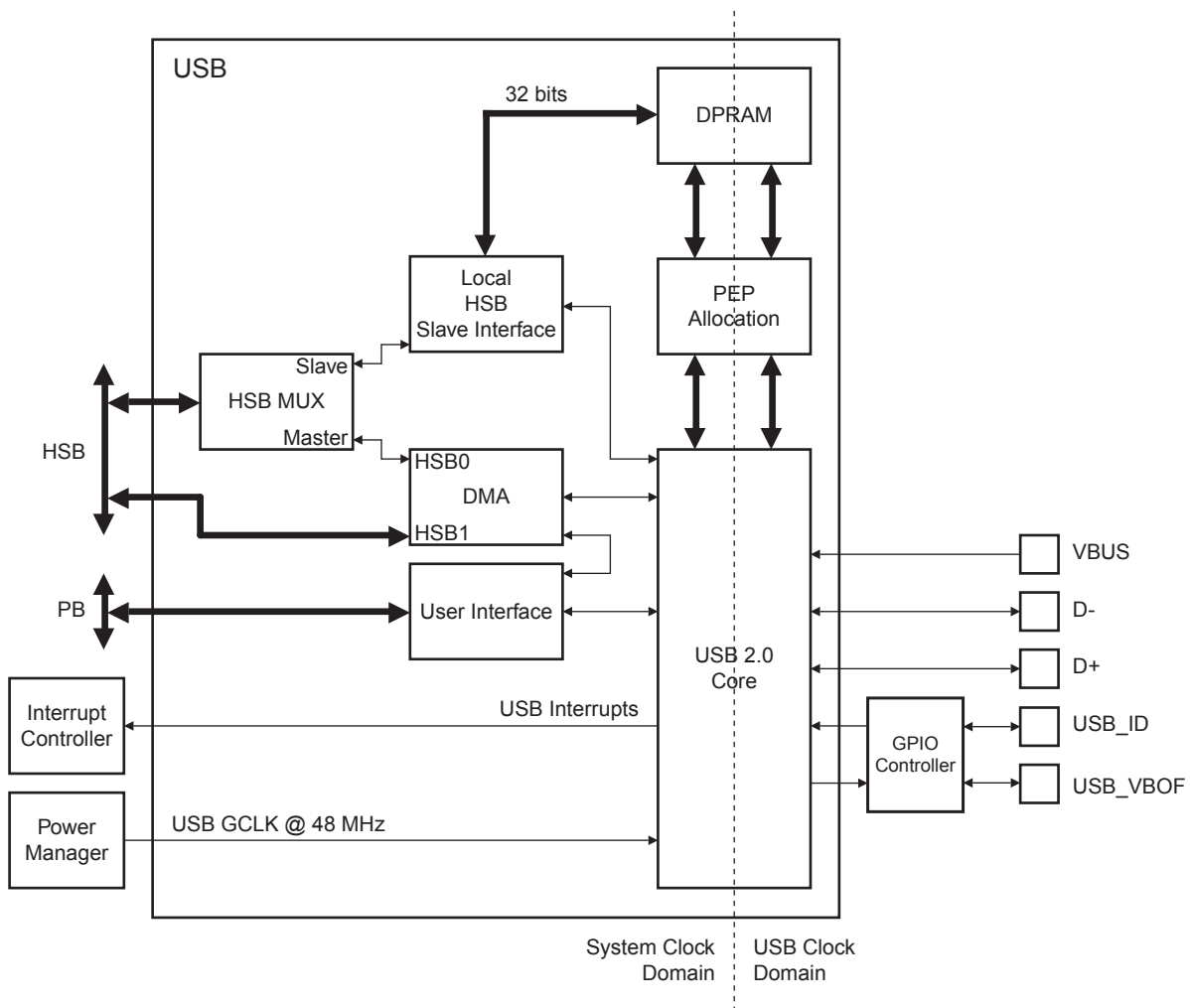

## 30.4 Application Block Diagram

Depending on the USB operating mode (device-only, reduced-host or OTG mode) and the power source (bus-powered or self-powered), there are different typical hardware implementations.

### 30.4.1 Device Mode

#### 30.4.1.1 Bus-Powered Device

**Figure 30-2.** Bus-Powered Device Application Block Diagram

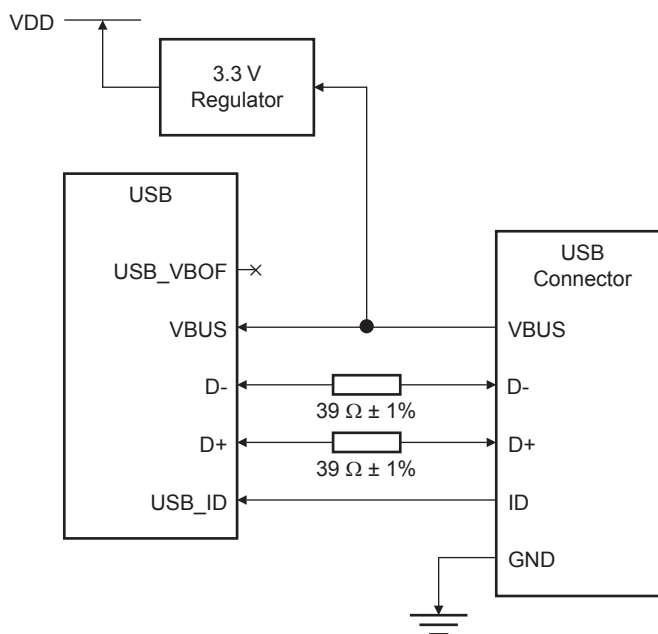

#### 30.4.1.2 Self-Powered Device

**Figure 30-3.** Self-Powered Device Application Block Diagram

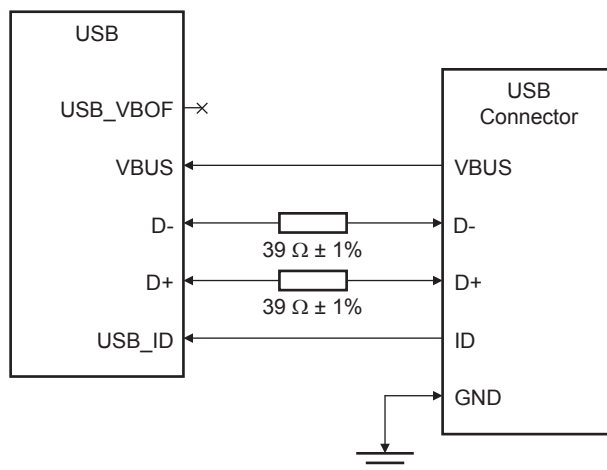

## 30.4.2 Host and OTG Modes

Figure 30-4. Host and OTG Application Block Diagram

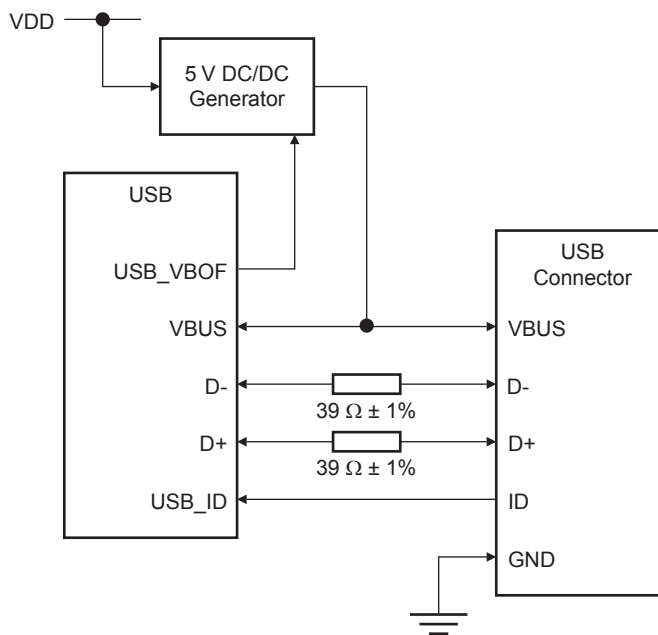

## 30.5 I/O Lines Description

Table 30-3. I/O Lines Description

Name	Description	Type	Active Level
USB_VBOF	USB VBus On/Off: Bus Power Control Port	Output	$\overline{\text{VBUSPO}}$
VBUS	VBus: Bus Power Measurement Port	Input	High
D-	Data -: Differential Data Line - Port	Input/Output	N/A
D+	Data +: Differential Data Line + Port	Input/Output	N/A
USB_ID	USB Identification: Mini Connector Identification Port	Input	Low: Mini-A plug High Z: Mini-B plug

## 30.6 Product Dependencies

### 30.6.1 I/O Lines

The USB\_VBOF and USB\_ID pins are multiplexed with GPIO lines and may also be multiplexed with lines of other peripherals. In order to use them with the USB, the programmer must first program the GPIO controller to assign them to their USB peripheral functions. Moreover, if USB\_ID is used, the GPIO controller must be configured to enable the internal pull-up resistor of its pin.

If USB\_VBOF or USB\_ID is not used by the application, the corresponding pin can be used for other purposes by the GPIO controller or by other peripherals.

### 30.6.2 Power Management

The 48 MHz USB clock is generated by a dedicated generic clock from the power manager. Before using the USB, the programmer must ensure that the USB generic clock (USB GCLK) is enabled at 48 MHz in the power manager.

### 30.6.3 Interrupts

The USB interface has an interrupt line connected to the interrupt controller. In order to handle USB interrupts, the interrupt controller must be programmed first.

## 30.7 Functional Description

### 30.7.1 USB General Operation

#### 30.7.1.1 Introduction

After a hardware reset, the USB controller is disabled. When enabled, the USB controller runs either in device mode or in host mode according to the ID detection.

If the USB\_ID pin is not connected to ground, the ID bit is set by hardware (the internal pull-up resistor of the USB\_ID pin must be enabled by the GPIO controller) and device mode is engaged.

The ID bit is cleared by hardware when a low level has been detected on the USB\_ID pin. Host mode is then engaged.

#### 30.7.1.2 Power-On and Reset

Figure 30-5 describes the USB controller main states.

**Figure 30-5.** General States

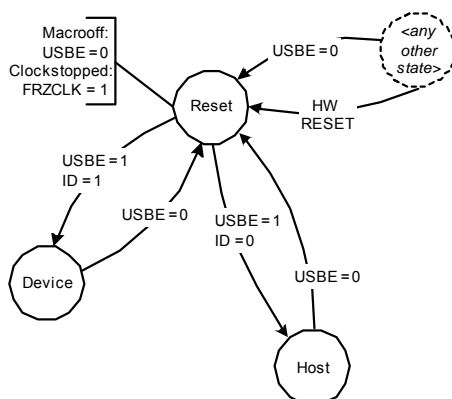

After a hardware reset, the USB controller is in the Reset state. In this state:

- the macro is disabled (USB\_E = 0);
- the macro clock is stopped in order to minimize power consumption (FRZCLK = 1);
- the pad is in suspend mode;
- the internal states and registers of the device and host modes are reset;
- the DPRAM is not cleared and is accessible;
- the ID and VBUS read-only bits reflect the states of the USB\_ID and VBUS input pins;
- the OTGPADE, VBUSPO, FRZCLK, USB\_E, UIDE, UIMOD and LS bits can be written by software, so that the user can program pads and speed before enabling the macro, but their value is only taken into account once the macro is enabled and unfrozen.

After setting USB\_E, the USB controller enters the Device or the Host mode (according to the ID detection) in idle state.

The USB controller can be disabled at any time by clearing USB\_E. In fact, clearing USB\_E acts as a hardware reset, except that the OTGPADE, VBUSPO, FRZCLK, UIDE, UIMOD and LS bits are not reset.

## 30.7.1.3 Interrupts

One interrupt vector is assigned to the USB interface. Figure 30-6 shows the structure of the USB interrupt system.

**Figure 30-6.** Interrupt System

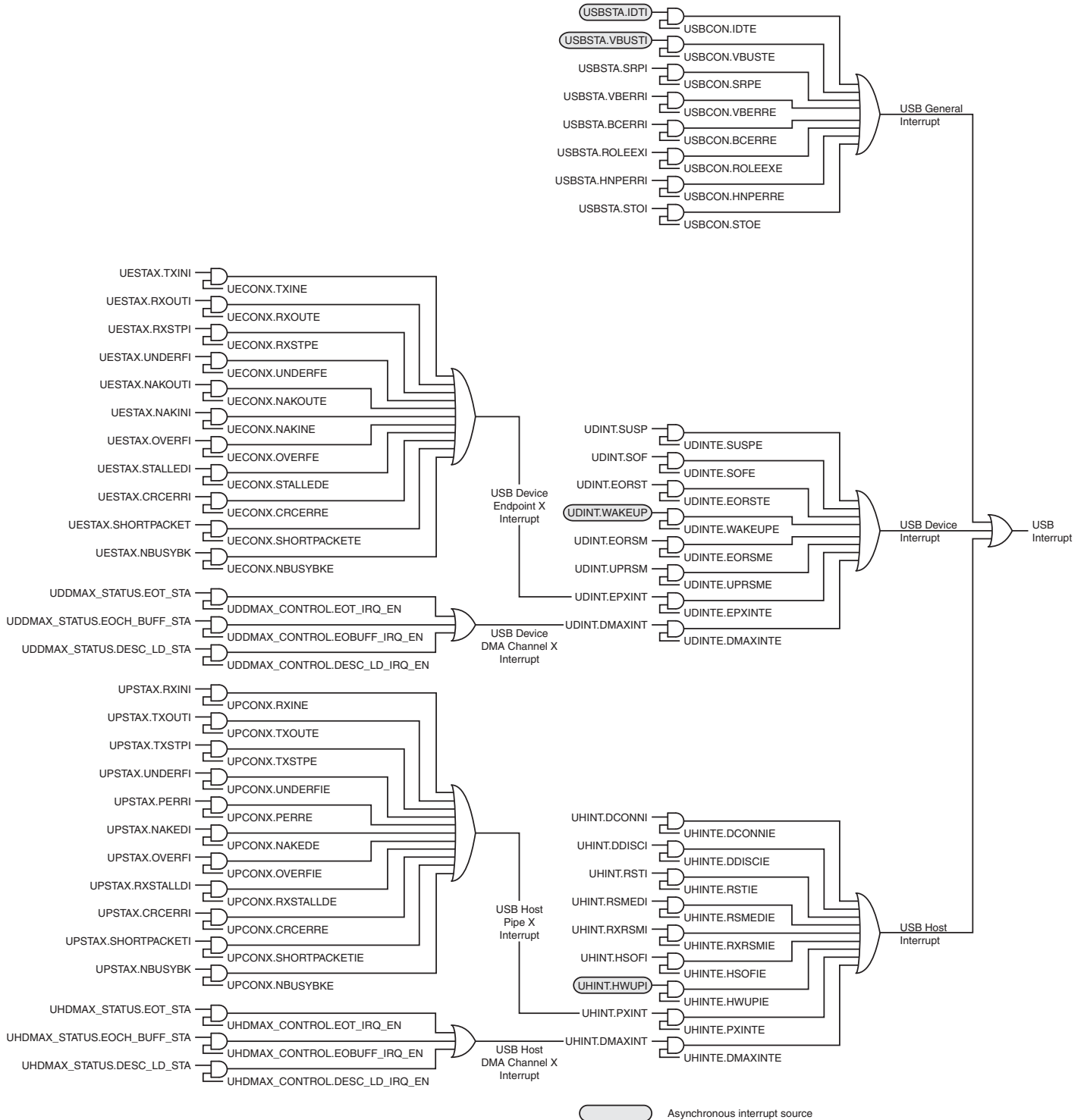



See [Section 30.7.2.17 on page 520](#) and [Section 30.7.3.13 on page 528](#) for further details about device and host interrupts.

There are two kinds of general interrupts: processing, i.e. their generation is part of the normal processing, and exception, i.e. errors (not related to CPU exceptions).

The processing general interrupts are:

- the ID Transition interrupt (IDTI);
- the VBus Transition interrupt (VBUSTI);
- the SRP interrupt (SRPI);
- the Role Exchange interrupt (ROLEEXI).

The exception general interrupts are:

- the VBus Error interrupt (VBERRI);
- the B-Connection Error interrupt (BCERRI);
- the HNP Error interrupt (HNPERRI);
- the Suspend Time-Out interrupt (STOI).

#### 30.7.1.4 *MCU Power Modes*

##### 30.7.1.4.1 *Run Mode*

In this mode, all MCU clocks can run, including the USB clock.

##### 30.7.1.4.2 *Idle Mode*

In this mode, the CPU is halted, i.e. the CPU clock is stopped. The Idle mode is entered whatever the state of the USB macro. The MCU wakes up on any USB interrupt.

##### 30.7.1.4.3 *Frozen Mode*

Same as the Idle mode, except that the HSB module is stopped, so the USB DMA, which is an HSB master, can not be used. Moreover, the USB DMA must be stopped before entering this sleep mode in order to avoid erratic behavior. The MCU wakes up on any USB interrupt.

##### 30.7.1.4.4 *Standby, Stop, DeepStop and Static Modes*

Same as the Frozen mode, except that the USB generic clock and other clocks are stopped, so the USB macro is frozen.

##### 30.7.1.4.5 *USB Clock Frozen*

In the Run, Idle and Frozen MCU modes, the USB macro can be frozen when the usb line is in the suspend mode, by setting the FRZCLK bit, what reduces power consumption.

In this case, it is still possible to access the following elements, but only in Run mode:

- the OTGPADE, VBUSPO, FRZCLK, USBE, UIDE, UIMOD and LS bits;
- the DPRAM (through the USB\_FIFOX\_DATA registers, but not through USB bus transfers which are frozen).

Moreover, when FRZCLK is set, only the asynchronous interrupt sources may trigger the USB interrupt:

- the ID Transition interrupt (IDTI);

- the VBus Transition interrupt (VBUSTI);
- the Wake-Up interrupt (WAKEUP);
- the Host Wake-Up interrupt (HWUPI).

### 30.7.1.4.6 USB Suspend mode :

In peripheral mode, the UDINT.SUSP bit indicates that the usb line is in the suspend mode. In this case, the USB Data transceiver is automatically set in suspend mode to reduce the consumption.

### 30.7.1.5 Speed Control

#### 30.7.1.5.1 Device Mode

When the USB interface is in device mode, the speed selection (full-/low-speed) depends on which of D+ and D- is pulled up. The LS bit allows to connect an internal pull-up resistor either on D+ (full-speed mode) or on D- (low-speed mode). The LS bit should be configured before attaching the device, what can be done by clearing the DETACH bit.

**Figure 30-7.** Speed Selection in Device Mode

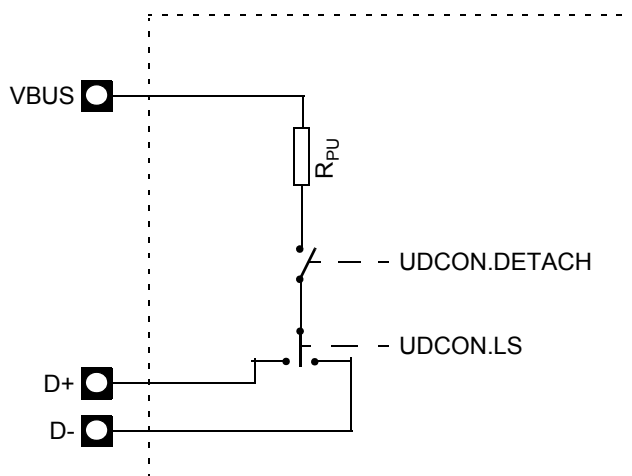

#### 30.7.1.5.2 Host Mode

When the USB interface is in host mode, internal pull-down resistors are connected on both D+ and D- and the interface detects the speed of the connected device, which is reflected by the SPEED bit-field.

#### 30.7.1.6 DPRAM Management

Pipes and endpoints can only be allocated in ascending order (from the pipe/endpoint 0 to the last pipe/endpoint to be allocated). The firmware shall therefore configure them in the same order.

The allocation of a pipe/endpoint  $k_i$  starts when its ALLOC bit is set. Then, the hardware allocates a memory area in the DPRAM and inserts it between the  $k_{i-1}$  and  $k_{i+1}$  pipes/endpoints. The  $k_{i+1}$  pipe/endpoint memory window slides up and its data is lost. Note that the following pipe/endpoint memory windows (from  $k_{i+2}$ ) do not slide.

Disabling a pipe (PENX = 0) or an endpoint (EPENX = 0) resets neither its ALLOC bit nor its configuration (PBK/EPBK, PSIZE/ESIZE, PTOKEN/EPDIR, PTYPE/EPTYPE, PEPNUM, INT-FRQ). To free its memory, the firmware should clear its ALLOC bit. The  $k_{i+1}$  pipe/endpoint memory window then slides down and its data is lost. Note that the following pipe/endpoint memory windows (from  $k_{i+2}$ ) do not slide.

Figure 30-8 illustrates the allocation and reorganization of the DPRAM in a typical example.

Figure 30-8. Allocation and Reorganization of the DPRAM

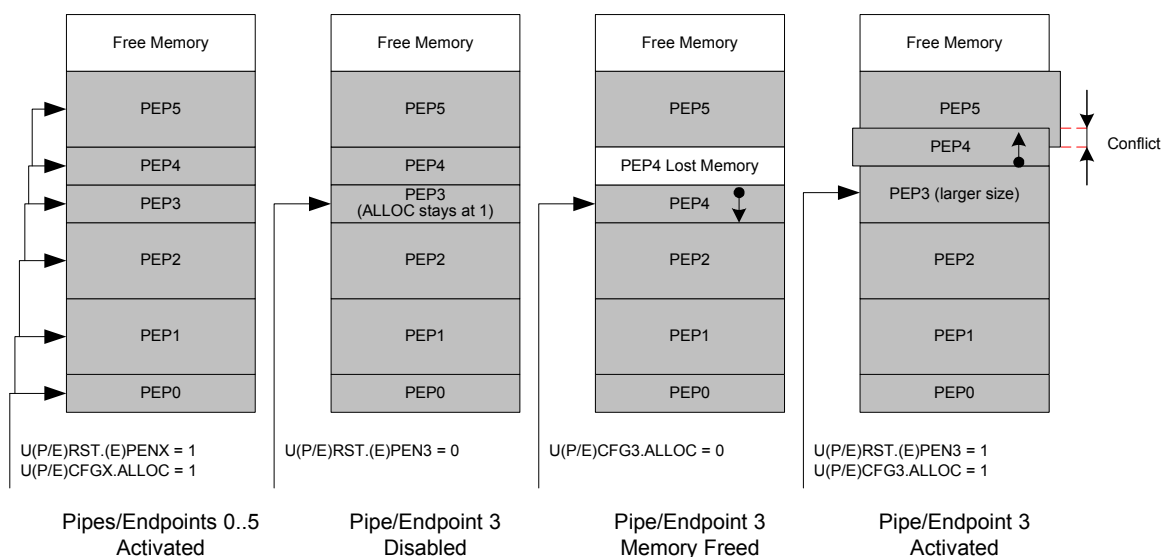

- First, the pipes/endpoints 0 to 5 are enabled, configured and allocated in ascending order. Each pipe/endpoint then owns a memory area in the DPRAM.
- Then, the pipe/endpoint 3 is disabled, but its memory is kept allocated by the controller.
- In order to free its memory, its ALLOC bit is then cleared by the firmware. The pipe/endpoint 4 memory window slides down, but the pipe/endpoint 5 does not move.
- Finally, if the firmware chooses to reconfigure the pipe/endpoint 3 with a larger size, the controller allocates a memory area after the pipe/endpoint 2 memory area and automatically slides up the pipe/endpoint 4 memory window. The pipe/endpoint 5 does not move and a memory conflict appears as the memory windows of the pipes/endpoints 4 and 5 overlap. The data of these pipes/endpoints is potentially lost.

Note that:

- there is no way the data of the pipe/endpoint 0 can be lost (except if it is de-allocated) as memory allocation and de-allocation may affect only higher pipes/endpoints;
- deactivating then reactivating a same pipe/endpoint with the same configuration only modifies temporarily the controller DPRAM pointer and size for this pipe/endpoint, but nothing changes in the DPRAM, so higher endpoints seem to not have been moved and their data is preserved as far as nothing has been written or received into them while changing the allocation state of the first pipe/endpoint;
- when the firmware sets the ALLOC bit, the CFGOK bit is set by hardware only if the configured size and number of banks are correct compared to their maximal allowed values for the endpoint and to the maximal FIFO size (i.e. the DPRAM size), so the value of CFGOK does not consider memory allocation conflicts.

30.7.1.7 Pad Suspend

Figure 30-9 shows the pad behavior.

Figure 30-9. Pad Behavior

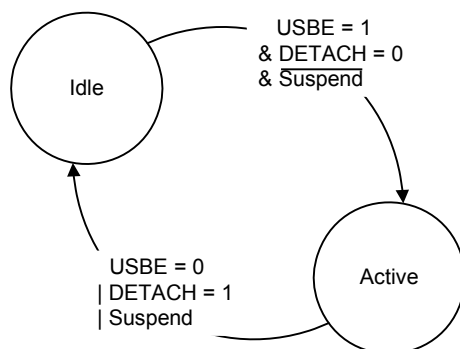

- In the Idle state, the pad is put in low power consumption mode.
- In the Active state, the pad is working.

Figure 30-10 illustrates the pad events leading to a PAD state change.

Figure 30-10. Pad Events

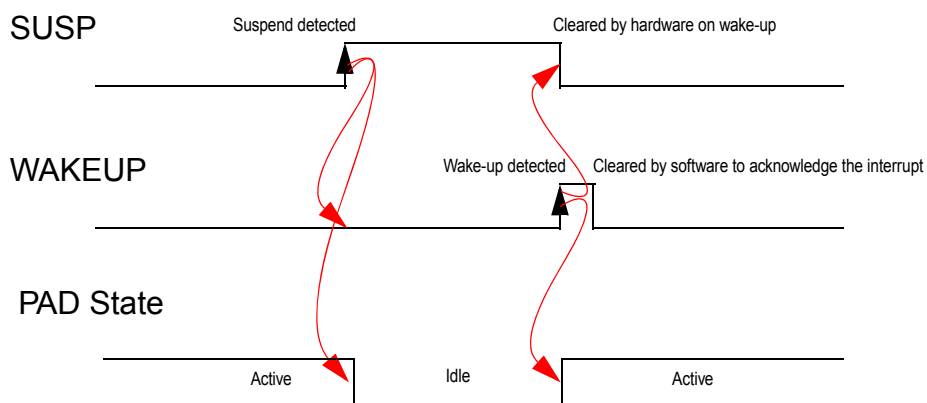

The Suspend interrupt flag (SUSP) is set and the Wake-Up interrupt flag (WAKEUP) is cleared when a USB “Suspend” state has been detected on the USB bus. This event automatically puts the USB pad in the Idle state. The detection of a non-idle event sets WAKEUP, clears SUSP and wakes up the USB pad.

Moreover, the pad goes to the Idle state if the macro is disabled or if the DETACH bit is set. It returns to the Active state when USBE = 1 and DETACH = 0.

## 30.7.1.8 Customizing of OTG Timers

It is possible to refine some OTG timers thanks to the TIMPAGE and TIMVALUE bit-fields, as shown by [Figure 30-4](#).

**Table 30-4.** Customizing of OTG Timers

		TIMPAGE			
		00b: AWaitVrise Time-Out ([OTG] Chapter 6.6.5.1)	01b: VbBusPulsing Time-Out ([OTG] Chapter 5.3.4)	10b: PdTmOutCnt Time-Out ([OTG] Chapter 5.3.2)	11b: SRPDetTmOut Time-Out ([OTG] Chapter 5.3.3)
TIMVALUE	00b	20 ms	15 ms	93 ms	10 μs
	01b	50 ms	23 ms	105 ms	100 μs
	10b	70 ms	31 ms	118 ms	1 ms
	11b	100 ms	40 ms	131 ms	11 ms

TIMPAGE is used to select the OTG timer to access while TIMVALUE indicates the time-out value of the selected timer.

TIMPAGE and TIMVALUE can be read or written. Before writing them, the firmware should unlock write accesses by setting the UNLOCK bit. This is not required for read accesses, except before accessing TIMPAGE if it has to be written in order to read the TIMVALUE bit-field of another OTG timer.

## 30.7.1.9 Plug-In Detection

The USB connection is detected from the VBUS pad. [Figure 30-11](#) shows the architecture of the plug-in detector.

**Figure 30-11.** Plug-In Detection Input Block Diagram

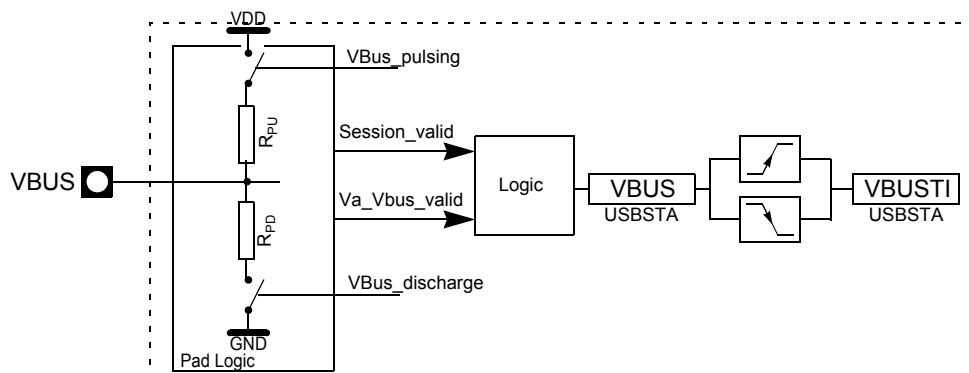

The control logic of the VBUS pad outputs two signals:

- the Session\_valid signal is high when the voltage on the VBUS pad is higher than or equal to 1.4 V;
- the Va\_Vbus\_valid signal is high when the voltage on the VBUS pad is higher than or equal to 4.4 V.

In device mode, the VBUS bit follows the Session\_valid comparator output:

- it is set when the voltage on the VBUS pad is higher than or equal to 1.4 V;

- it is cleared when the voltage on the VBUS pad is lower than 1.4 V.

In host mode, the VBUS bit follows an hysteresis based on Session\_valid and Va\_Vbus\_valid:

- it is set when the voltage on the VBUS pad is higher than or equal to 4.4 V;
- it is cleared when the voltage on the VBUS pad is lower than 1.4 V.

The VBus Transition interrupt (VBUSTI) is raised on each transition of the VBUS bit.

The VBUS bit is effective whether the USB macro is enabled or not.

### 30.7.1.10 ID Detection

Figure 30-12 shows how the ID transitions are detected.

**Figure 30-12.** ID Detection Input Block Diagram

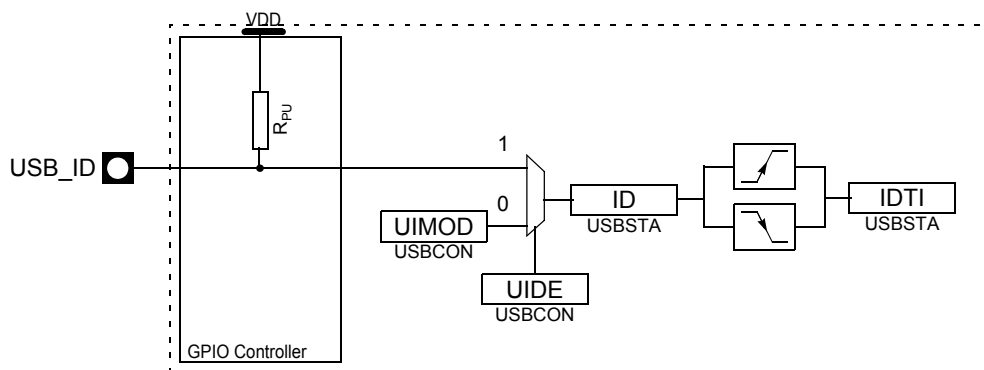

The USB mode (device or host) can be either detected from the USB\_ID pin or software selected from the UIMOD bit, according to the UIDE bit. This allows the USB\_ID pin to be used as a general purpose I/O pin even when the USB interface is enabled.

By default, the USB\_ID pin is selected (UIDE = 1) and the USB macro is in device mode (ID = 1), what corresponds to the case where no Mini-A plug is connected, i.e. no plug or a Mini-B plug is connected and the USB\_ID pin is kept high by the internal pull-up resistor from the GPIO controller (which must be enabled if USB\_ID is used).

The ID Transition interrupt (IDTI) is raised on each transition of the ID bit, i.e. when a Mini-A plug (host mode) is connected or disconnected. This does not occur when a Mini-B plug (device mode) is connected or disconnected.

The ID bit is effective whether the USB macro is enabled or not.

## 30.7.2 USB Device Operation

### 30.7.2.1 Introduction

In device mode, the USB controller supports full- and low-speed data transfers.

In addition to the default control endpoint, six endpoints are provided, which can be configured with the types isochronous, bulk or interrupt, as described in [Table 30-1 on page 497](#).

The device mode starts in the Idle state, so the pad consumption is reduced to the minimum.

### 30.7.2.2 Power-On and Reset

[Figure 30-13](#) describes the USB controller device mode main states.

**Figure 30-13.** Device Mode States

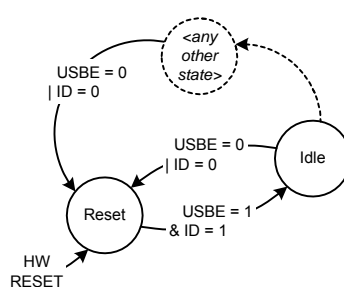

After a hardware reset, the USB controller device mode is in the Reset state. In this state:

- the macro clock is stopped in order to minimize power consumption (FRZCLK = 1);
- the internal registers of the device mode are reset;
- the endpoint banks are de-allocated;
- neither D+ nor D- is pulled up (DETACH = 1).

D+ or D- will be pulled up according to the selected speed as soon as the DETACH bit is cleared and VBus is present. See [Section 30.7.1.5.1 on page 506](#) for further details.

When the USB macro is enabled (USBE = 1) in device mode (ID = 1), its device mode state goes to the Idle state with minimal power consumption. This does not require the USB clock to be activated.

The USB controller device mode can be disabled and reset at any time by disabling the USB macro (USBE = 0) or when host mode is engaged (ID = 0).

### 30.7.2.3 USB Reset

The USB bus reset is managed by hardware. It is initiated by a connected host.

When a USB reset is detected on the USB line, the following operations are performed by the controller:

- all the endpoints are disabled, except the default control endpoint;
- the default control endpoint is reset (see [Section 30.7.2.4 on page 512](#) for more details);
- the data toggle sequence of the default control endpoint is cleared;
- at the end of the reset process, the End of Reset interrupt (EORST) is raised.

## 30.7.2.4 Endpoint Reset

An endpoint can be reset at any time by setting its EPRSTX bit in the UERST register. This is recommended before using an endpoint upon hardware reset or when a USB bus reset has been received. This resets:

- the internal state machine of this endpoint;
- the receive and transmit bank FIFO counters;
- all the registers of this endpoint (UECFGX, UESTAX, UECONX), except its configuration (ALLOC, EPBK, EPSIZE, EPDIR, EPTYPE) and its Data Toggle Sequence bit-field (DTSEQ).

Note that the interrupt sources located in the UESTAX register are not cleared when a USB bus reset has been received.

The endpoint configuration remains active and the endpoint is still enabled.

The endpoint reset may be associated with a clear of the data toggle sequence as an answer to the CLEAR\_FEATURE USB request. This can be achieved by setting the RSTDTR bit (by setting the RSTDTS bit).

In the end, the firmware has to clear the EPRSTX bit to complete the reset operation and to start using the FIFO.

## 30.7.2.5 Endpoint Activation

The endpoint is maintained inactive and reset (see [Section 30.7.2.4 on page 512](#) for more details) as long as it is disabled (EPENX = 0). The Data Toggle Sequence bit-field (DTSEQ) is also reset.

The algorithm represented on [Figure 30-14](#) must be followed in order to activate an endpoint.

**Figure 30-14.** Endpoint Activation Algorithm

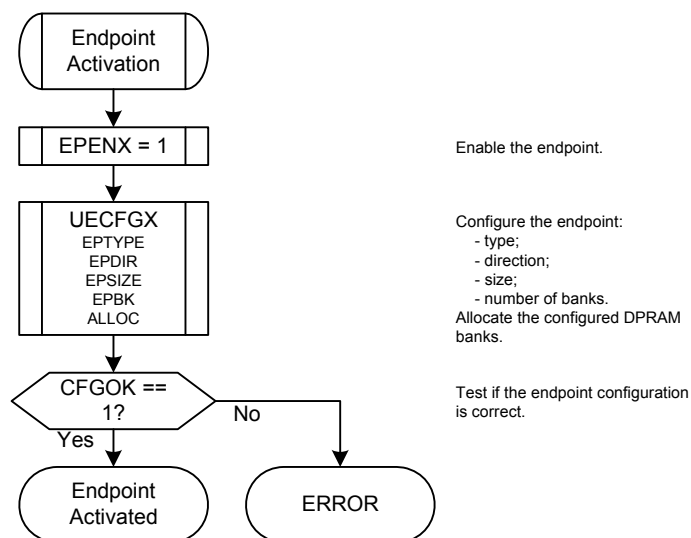

As long as the endpoint is not correctly configured (CFGOK = 0), the controller does not acknowledge the packets sent by the host to this endpoint.

The CFGOK bit is set by hardware only if the configured size and number of banks are correct compared to their maximal allowed values for the endpoint (see [Table 30-1 on page 497](#)) and to the maximal FIFO size (i.e. the DPRAM size).



See [Section 30.7.1.6 on page 506](#) for more details about DPRAM management.

### 30.7.2.6 Address Setup

The USB device address is set up according to the USB protocol:

- after all kinds of resets, the USB device address is 0;
- the host starts a SETUP transaction with a SET\_ADDRESS(addr) request;
- the firmware records this address into the UADD bit-field, leaving the ADDEN bit cleared, so the actual address is still 0;
- the firmware sends a zero-length IN packet from the control endpoint;
- the firmware enables the recorded USB device address by setting ADDEN.

Once the USB device address is configured, the controller filters the packets to only accept those targeting the address stored in UADD.

UADD and ADDEN shall not be written all at once.

UADD and ADDEN are cleared by hardware:

- on a hardware reset;
- when the USB macro is disabled (USBE = 0);
- when a USB reset is detected.

When UADD or ADDEN is cleared, the default device address 0 is used.

### 30.7.2.7 Suspend and Wake-Up

When an idle USB bus state has been detected for 3 ms, the controller raises the Suspend interrupt (SUSP). The firmware may then set the FRZCLK bit to reduce power consumption. The MCU can also enter the Idle or Frozen sleep mode to lower again power consumption.

To recover from the Suspend mode, the firmware should wait for the Wake-Up interrupt (WAKEUP), which is raised when a non-idle event is detected, then clear FRZCLK.

As the WAKEUP interrupt is raised when a non-idle event is detected, it can occur whether the controller is in the Suspend mode or not. The SUSP and WAKEUP interrupts are thus independent of each other except that one's flag is cleared by hardware when the other is raised.

### 30.7.2.8 Detach

The reset value of the DETACH bit is 1.

It is possible to initiate a device re-enumeration simply by setting then clearing DETACH.

DETACH acts on the pull-up connections of the D+ and D- pads. See [Section 30.7.1.5.1 on page 506](#) for further details.

### 30.7.2.9 Remote Wake-Up

The Remote Wake-Up request (also known as Upstream Resume) is the only one the device may send on its own initiative, but the device should have beforehand been allowed to by a DEVICE\_REMOTE\_WAKEUP request from the host.

- First, the USB controller must have detected a "Suspend" state on the bus, i.e. the Remote Wake-Up request can only be sent after a SUSP interrupt has been raised.

- The firmware may then set the RMWKUP bit to send an upstream resume to the host for a remote wake-up. This will automatically be done by the controller after 5 ms of inactivity on the USB bus.
- When the controller sends the upstream resume, the Upstream Resume interrupt (UPRSM) is raised and SUSP is cleared by hardware.
- RMWKUP is cleared by hardware at the end of the upstream resume.
- If the controller detects a valid “End of Resume” signal from the host, the End of Resume interrupt (EORSM) is raised.

### 30.7.2.10 *STALL Request*

For each endpoint, the STALL management is performed using:

- the STALL Request bit (STALLRQ) to initiate a STALL request;
- the STALLED interrupt (STALLEDI) raised when a STALL handshake has been sent.

To answer the next request with a STALL handshake, STALLRQ has to be set by setting the STALLRQS bit. All following requests will be discarded (RXOUTI, etc. will not be set) and handshaked with a STALL until the STALLRQ bit is cleared, what is done by hardware when a new SETUP packet is received (for control endpoints) or when the STALLRQC bit is set.

Each time a STALL handshake is sent, the STALLEDI flag is set by the USB controller and the EPXINT interrupt is raised.

#### 30.7.2.10.1 *Special Considerations for Control Endpoints*

If a SETUP packet is received into a control endpoint for which a STALL is requested, the Received SETUP interrupt (RXSTPI) is raised and STALLRQ and STALLEDI are cleared by hardware. The SETUP has to be ACKed.

This management simplifies the enumeration process management. If a command is not supported or contains an error, the firmware requests a STALL and can return to the main task, waiting for the next SETUP request.

#### 30.7.2.10.2 *STALL Handshake and Retry Mechanism*

The retry mechanism has priority over the STALL handshake. A STALL handshake is sent if the STALLRQ bit is set and if there is no retry required.

### 30.7.2.11 *Management of Control Endpoints*

#### 30.7.2.11.1 *Overview*

A SETUP request is always ACKed. When a new SETUP packet is received, the Received SETUP interrupt (RXSTPI) is raised, but not the Received OUT Data interrupt (RXOUTI).

The FIFOCON and RWALL bits are irrelevant for control endpoints. The firmware shall therefore never use them on these endpoints. When read, their value is always 0.

Control endpoints are managed using:

- the Received SETUP interrupt (RXSTPI) which is raised when a new SETUP packet is received and which shall be cleared by firmware to acknowledge the packet and to free the bank;

- the Received OUT Data interrupt (RXOUTI) which is raised when a new OUT packet is received and which shall be cleared by firmware to acknowledge the packet and to free the bank;
- the Transmitted IN Data interrupt (TXINI) which is raised when the current bank is ready to accept a new IN packet and which shall be cleared by firmware to send the packet.

### 30.7.2.11.2 Control Write

Figure 30-15 shows a control write transaction. During the status stage, the controller will not necessarily send a NAK on the first IN token:

- if the firmware knows the exact number of descriptor bytes that must be read, it can then anticipate the status stage and send a zero-length packet after the next IN token;
- or it can read the bytes and wait for the NAKed IN interrupt (NAKINI) which tells that all the bytes have been sent by the host and that the transaction is now in the status stage.

Figure 30-15. Control Write

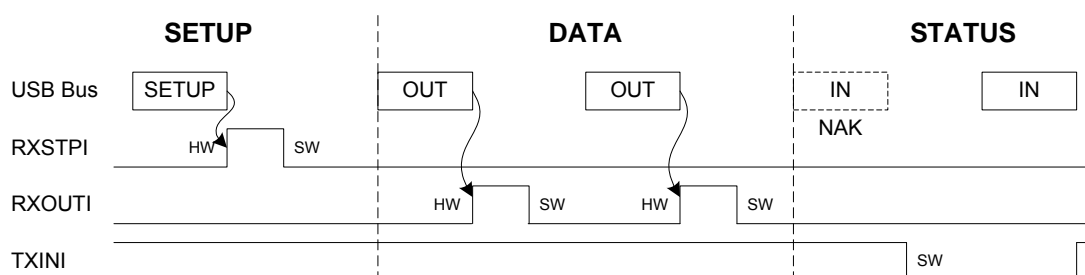

### 30.7.2.11.3 Control Read

Figure 30-16 shows a control read transaction. The USB controller has to manage the simultaneous write requests from the CPU and the USB host.

Figure 30-16. Control Read

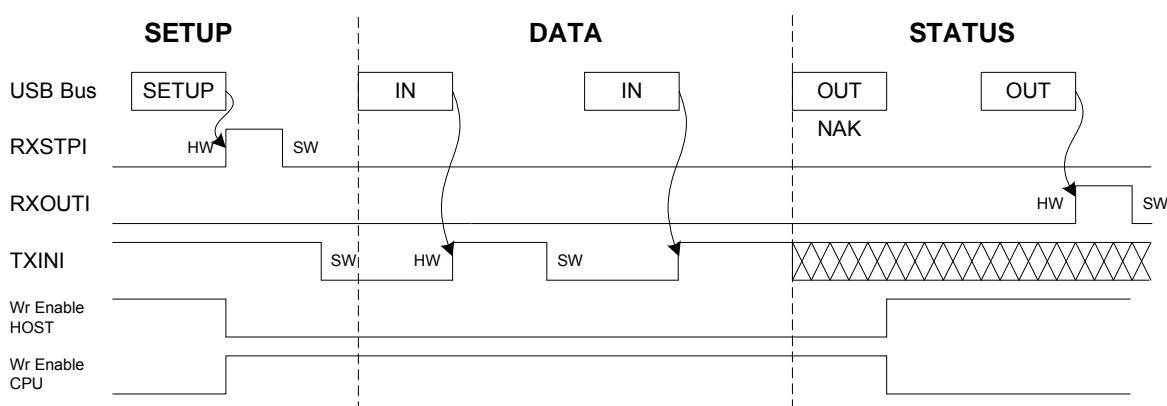

A NAK handshake is always generated on the first status stage command.

When the controller detects the status stage, all the data written by the CPU is lost and clearing TXINI has no effect.

The firmware checks if the transmission or the reception is complete.

The OUT retry is always ACKed. This reception sets RXOUTI and TXINI. Handle this with the following software algorithm:

```

set TXINI
wait for RXOUTI OR TXINI
if RXOUTI, then clear flag and return
if TXINI, then continue
    
```

Once the OUT status stage has been received, the USB controller waits for a SETUP request. The SETUP request has priority over any other request and has to be ACKed. This means that any other flag should be cleared and the FIFO reset when a SETUP is received.

The firmware has to take care of the fact that the byte counter is reset when a zero-length OUT packet is received.

### 30.7.2.12 Management of IN Endpoints

#### 30.7.2.12.1 Overview

IN packets are sent by the USB device controller upon IN requests from the host. All the data can be written by the firmware which acknowledges or not the bank when it is full.

The endpoint must be configured first.

The TXINI bit is set by hardware at the same time as FIFOCON when the current bank is free. This triggers an EPXINT interrupt if TXINE = 1.

TXINI shall be cleared by software (by setting the TXINIC bit) to acknowledge the interrupt, what has no effect on the endpoint FIFO.

The firmware then writes into the FIFO and clears the FIFOCON bit to allow the USB controller to send the data. If the IN endpoint is composed of multiple banks, this also switches to the next bank. The TXINI and FIFOCON bits are updated by hardware in accordance with the status of the next bank.

TXINI shall always be cleared before clearing FIFOCON.

The RWALL bit is set by hardware when the current bank is not full, i.e. the software can write further data into the FIFO.

**Figure 30-17.** Example of an IN Endpoint with 1 Data Bank

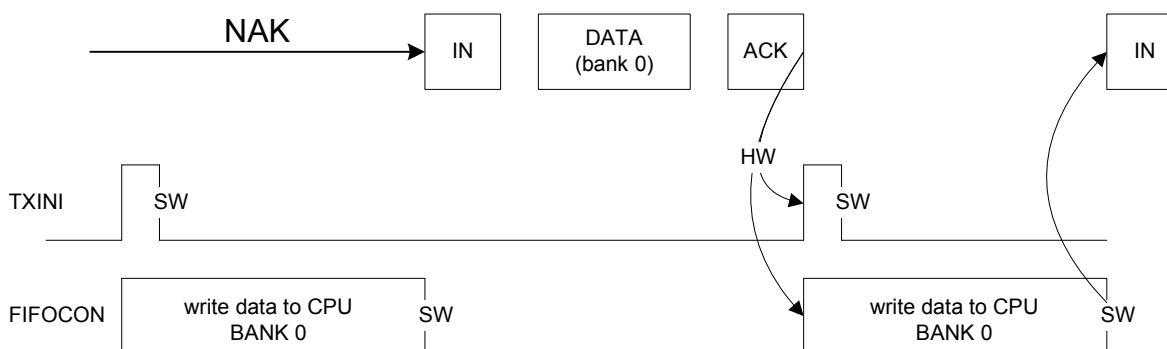
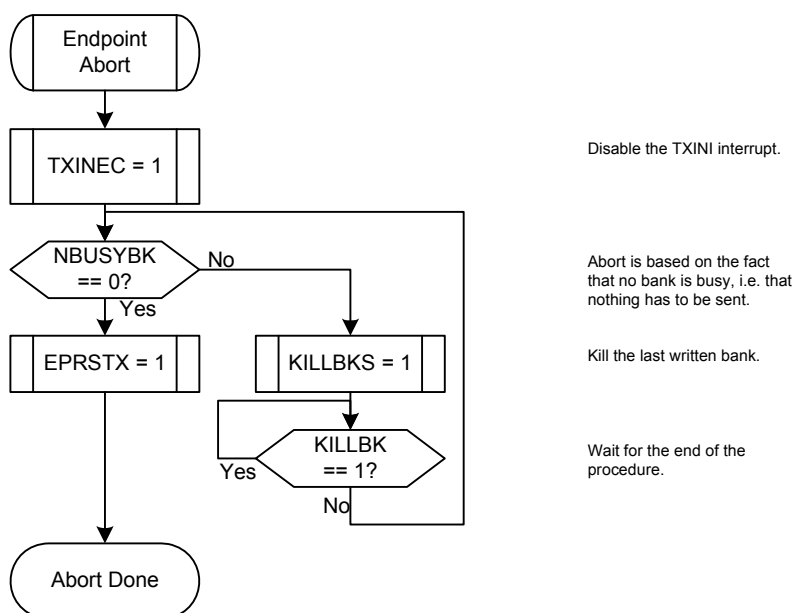



Figure 30-19. Abort Algorithm



### 30.7.2.13 Management of OUT Endpoints

#### 30.7.2.13.1 Overview

OUT packets are sent by the host. All the data can be read by the firmware which acknowledges or not the bank when it is empty.

The endpoint must be configured first.

The RXOUTI bit is set by hardware at the same time as FIFOCON when the current bank is full. This triggers an EPXINT interrupt if RXOUTE = 1.

RXOUTI shall be cleared by software (by setting the RXOUTIC bit) to acknowledge the interrupt, what has no effect on the endpoint FIFO.

The firmware then reads from the FIFO and clears the FIFOCON bit to free the bank. If the OUT endpoint is composed of multiple banks, this also switches to the next bank. The RXOUTI and FIFOCON bits are updated by hardware in accordance with the status of the next bank.

RXOUTI shall always be cleared before clearing FIFOCON.

The RWALL bit is set by hardware when the current bank is not empty, i.e. the software can read further data from the FIFO.

**Figure 30-20.** Example of an OUT Endpoint with 1 Data Bank

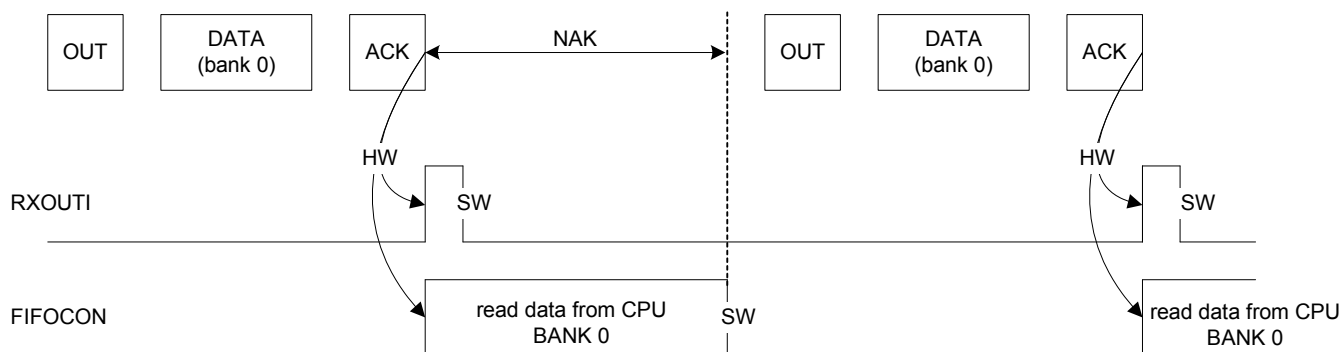

**Figure 30-21.** Example of an OUT Endpoint with 2 Data Banks

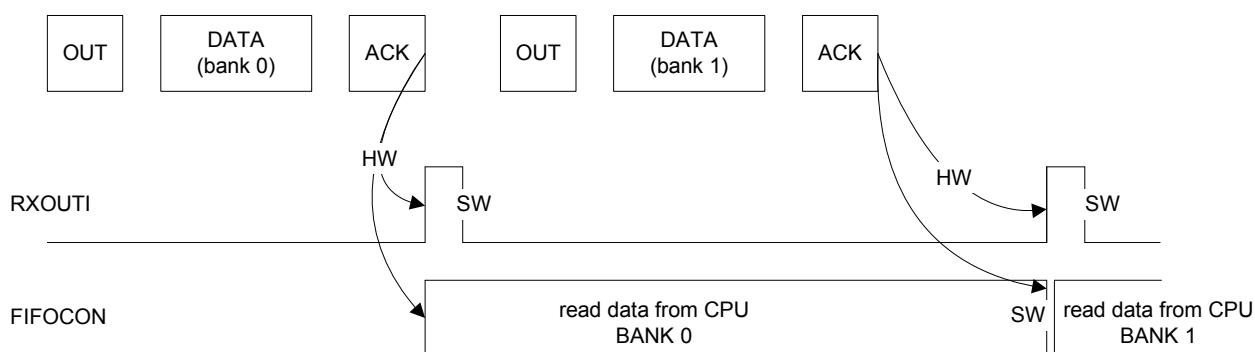

### 30.7.2.13.2 Detailed Description

The data is read by the firmware, following the next flow:

- when the bank is full, RXOUTI and FIFOCON are set, what triggers an EPXINT interrupt if RXOUTE = 1;
- the firmware acknowledges the interrupt by clearing RXOUTI;
- the firmware can read the byte count of the current bank from BYCT to know how many bytes to read, rather than polling RWALL;
- the firmware reads the data from the current bank by using the USB Pipe/Endpoint X FIFO Data register (USB\_FIFOX\_DATA), until all the expected data frame is read or the bank is empty (in which case RWALL is cleared by hardware and BYCT reaches 0);
- the firmware frees the bank and switches to the next bank (if any) by clearing FIFOCON.

If the endpoint uses several banks, the current one can be read by the firmware while the following one is being written by the host. Then, when the firmware clears FIFOCON, the following bank may already be ready and RXOUTI is set immediately.

### 30.7.2.14 Underflow

This error exists only for isochronous IN/OUT endpoints. It raises the Underflow interrupt (UNDERFI), what triggers an EPXINT interrupt if UNDERFE = 1.

An underflow can occur during IN stage if the host attempts to read from an empty bank. A zero-length packet is then automatically sent by the USB controller.

An underflow can not occur during OUT stage on a CPU action, since the firmware may read only if the bank is not empty (RXOUTI = 1 or RWALL = 1).

An underflow can also occur during OUT stage if the host sends a packet while the bank is already full. Typically, the CPU is not fast enough. The packet is lost.

An underflow can not occur during IN stage on a CPU action, since the firmware may write only if the bank is not full (TXINI = 1 or RWALL = 1).

### 30.7.2.15 Overflow

This error exists for all endpoint types. It raises the Overflow interrupt (OVERFI), what triggers an EPXINT interrupt if OVERFE = 1.

An overflow can occur during OUT stage if the host attempts to write into a bank that is too small for the packet. The packet is acknowledged and the Received OUT Data interrupt (RXOUTI) is raised as if no overflow had occurred. The bank is filled with all the first bytes of the packet that fit in.

An overflow can not occur during IN stage on a CPU action, since the firmware may write only if the bank is not full (TXINI = 1 or RWALL = 1).

### 30.7.2.16 CRC Error

This error exists only for isochronous OUT endpoints. It raises the CRC Error interrupt (CRCERRI), what triggers an EPXINT interrupt if CRCERRE = 1.

A CRC error can occur during OUT stage if the USB controller detects a corrupted received packet. The OUT packet is stored in the bank as if no CRC error had occurred (RXOUTI is raised).

### 30.7.2.17 Interrupts

See the structure of the USB device interrupt system on [Figure 30-6 on page 504](#).

There are two kinds of device interrupts: processing, i.e. their generation is part of the normal processing, and exception, i.e. errors (not related to CPU exceptions).

#### 30.7.2.17.1 Global Interrupts

The processing device global interrupts are:

- the Suspend interrupt (SUSP);
- the Start of Frame interrupt (SOF) with no frame number CRC error (FNCERR = 0);
- the End of Reset interrupt (EORST);
- the Wake-Up interrupt (WAKEUP);
- the End of Resume interrupt (EORSM);
- the Upstream Resume interrupt (UPRSM);
- the Endpoint X interrupt (EPXINT);
- the DMA Channel X interrupt (DMAXINT).

The exception device global interrupts are:

- the Start of Frame interrupt (SOF) with a frame number CRC error (FNCERR = 1).



### 30.7.2.17.2 Endpoint Interrupts

The processing device endpoint interrupts are:

- the Transmitted IN Data interrupt (TXINI);
- the Received OUT Data interrupt (RXOUTI);
- the Received SETUP interrupt (RXSTPI);
- the Short Packet interrupt (SHORTPACKET);
- the Number of Busy Banks interrupt (NBUSYBK).

The exception device endpoint interrupts are:

- the Underflow interrupt (UNDERFI);
- the NAKed OUT interrupt (NAKOUTI);
- the NAKed IN interrupt (NAKINI);
- the Overflow interrupt (OVERFI);
- the STALLED interrupt (STALLEDI);
- the CRC Error interrupt (CRCERRI);

### 30.7.2.17.3 DMA Interrupts

The processing device DMA interrupts are:

- the End of USB Transfer Status interrupt (EOT\_STA);
- the End of Channel Buffer Status interrupt (EOCH\_BUFF\_STA);
- the Descriptor Loaded Status interrupt (DESC\_LD\_STA).

There is no exception device DMA interrupt.

## 30.7.3 USB Host Operation

### 30.7.3.1 Description of Pipes

For the USB controller in host mode, the term “pipe” is used instead of “endpoint” (used in device mode). A host pipe corresponds to a device endpoint, as described by the [Figure 30-22](#) from the USB specification.

**Figure 30-22.** USB Communication Flow

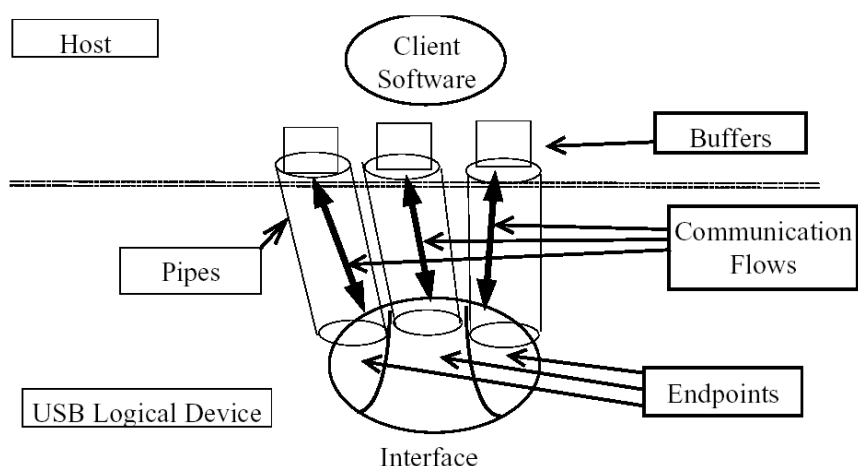

In host mode, the USB controller associates a pipe to a device endpoint, considering the device configuration descriptors.

### 30.7.3.2 Power-On and Reset

[Figure 30-23](#) describes the USB controller host mode main states.

**Figure 30-23.** Host Mode States

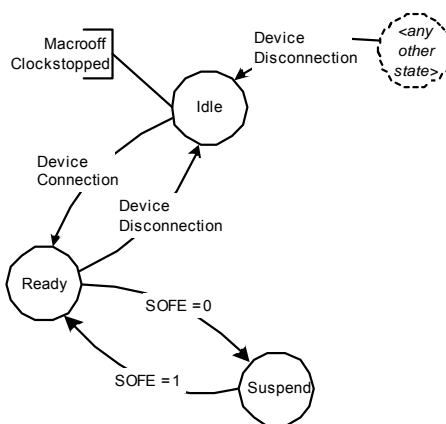

After a hardware reset, the USB controller host mode is in the Reset state.

When the USB macro is enabled (USBE = 1) in host mode (ID = 0), its host mode state goes to the Idle state. In this state, the controller waits for device connection with minimal power consumption. The USB pad should be in the Idle state. Once a device is connected, the macro enters the Ready state, what does not require the USB clock to be activated.

The controller enters the Suspend state when the USB bus is in a “Suspend” state, i.e. when the host mode does not generate the “Start of Frame”. In this state, the USB consumption is minimal. The host mode exits the Suspend state when starting to generate the SOF over the USB line.

### 30.7.3.3 Device Detection

A device is detected by the USB controller host mode when D+ or D- is no longer tied low, i.e. when the device D+ or D- pull-up resistor is connected. To enable this detection, the host controller has to provide the VBus power supply to the device by setting the VBUSRQ bit (by setting the VBUSRQS bit).

The device disconnection is detected by the host controller when both D+ and D- are pulled down.

### 30.7.3.4 USB Reset

The USB controller sends a USB bus reset when the firmware sets the RESET bit. The USB Reset Sent interrupt (RSTI) is raised when the USB reset has been sent. In this case, all the pipes are disabled and de-allocated.

If the bus was previously in a “Suspend” state (SOFE = 0), the USB controller automatically switches it to the “Resume” state, the Host Wake-Up interrupt (HWUPI) is raised and the SOFE bit is set by hardware in order to generate SOFs immediately after the USB reset.

### 30.7.3.5 Pipe Reset

A pipe can be reset at any time by setting its PRSTX bit in the UPRST register. This is recommended before using a pipe upon hardware reset or when a USB bus reset has been sent. This resets:

- the internal state machine of this pipe;
- the receive and transmit bank FIFO counters;
- all the registers of this pipe (UPCFGX, UPSTAX, UPCONX), except its configuration (ALLOC, PBK, PSIZE, PTOKEN, PTYPE, PEPNUM, INTFRQ) and its Data Toggle Sequence bit-field (DTSEQ).

The pipe configuration remains active and the pipe is still enabled.

The pipe reset may be associated with a clear of the data toggle sequence. This can be achieved by setting the RSTDT bit (by setting the RSTDTS bit).

In the end, the firmware has to clear the PRSTX bit to complete the reset operation and to start using the FIFO.

### 30.7.3.6 Pipe Activation

The pipe is maintained inactive and reset (see [Section 30.7.3.5 on page 523](#) for more details) as long as it is disabled (PENX = 0). The Data Toggle Sequence bit-field (DTSEQ) is also reset.

The algorithm represented on [Figure 30-24](#) must be followed in order to activate a pipe.

**Figure 30-24.** Pipe Activation Algorithm

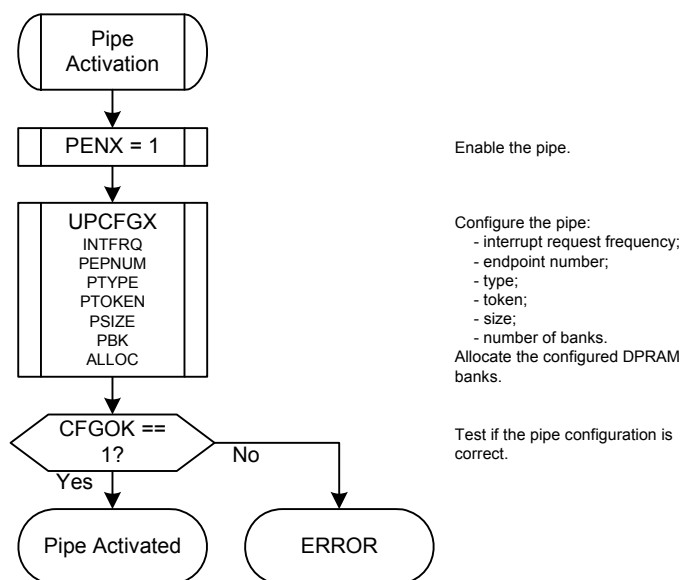

As long as the pipe is not correctly configured (CFGOK = 0), the controller can not send packets to the device through this pipe.

The CFGOK bit is set by hardware only if the configured size and number of banks are correct compared to their maximal allowed values for the pipe (see [Table 30-1 on page 497](#)) and to the maximal FIFO size (i.e. the DPRAM size).

See [Section 30.7.1.6 on page 506](#) for more details about DPRAM management.

Once the pipe is correctly configured (CFGOK = 1), only the PTOKEN and INTFRQ bit-fields can be modified by software. INTFRQ is meaningless for non-interrupt pipes.

When starting an enumeration, the firmware gets the device descriptor by sending a GET\_DESCRIPTOR USB request. This descriptor contains the maximal packet size of the device default control endpoint (bMaxPacketSize0) and the firmware re-configures the size of the default control pipe with this size parameter.

### 30.7.3.7 Address Setup

Once the device has answered the first host requests with the default device address 0, the host assigns a new address to the device. The host controller has to send a USB reset to the device and to send a SET\_ADDRESS(addr) SETUP request with the new address to be used by the device. Once this SETUP transaction is over, the firmware writes the new address into the HADDR bit-field. All following requests, on all pipes, will be performed using this new address.

When the host controller sends a USB reset, the HADDR bit-field is reset by hardware and the following host requests will be performed using the default device address 0.

### 30.7.3.8 Remote Wake-Up

The controller host mode enters the Suspend state when the SOFE bit is cleared. No more “Start of Frame” is sent on the USB bus and the USB device enters the Suspend state 3 ms later.

The device awakes the host by sending an Upstream Resume (Remote Wake-Up feature). When the host controller detects a non-idle state on the USB bus, it raises the Host Wake-Up

interrupt (HWUPI). If the non-idle bus state corresponds to an Upstream Resume (K state), the Upstream Resume Received interrupt (RXRSMI) is raised. The firmware has to generate a Downstream Resume within 1 ms and for at least 20 ms by setting the RESUME bit. It is mandatory to set SOFE before setting RESUME to enter the Ready state, else RESUME will have no effect.

### 30.7.3.9 Management of Control Pipes

A control transaction is composed of three stages:

- SETUP;
- Data (IN or OUT);
- Status (OUT or IN).

The firmware has to change the pipe token according to each stage.

For the control pipe, and only for it, each token is assigned a specific initial data toggle sequence:

- SETUP: Data0;
- IN: Data1;
- OUT: Data1.

### 30.7.3.10 Management of IN Pipes

IN packets are sent by the USB device controller upon IN requests from the host. All the data can be read by the firmware which acknowledges or not the bank when it is empty.

The pipe must be configured first.

When the host requires data from the device, the firmware has to select beforehand the IN request mode with the INMODE bit:

- when INMODE is cleared, the USB controller will perform (INRQ + 1) IN requests before freezing the pipe;
- when INMODE is set, the USB controller will perform IN requests endlessly when the pipe is not frozen by the firmware.

The generation of IN requests starts when the pipe is unfrozen (PFREEZE = 0).

The RXINI bit is set by hardware at the same time as FIFOCON when the current bank is full. This triggers a PXINT interrupt if RXINE = 1.

RXINI shall be cleared by software (by setting the RXINIC bit) to acknowledge the interrupt, what has no effect on the pipe FIFO.

The firmware then reads from the FIFO and clears the FIFOCON bit to free the bank. If the IN pipe is composed of multiple banks, this also switches to the next bank. The RXINI and FIFOCON bits are updated by hardware in accordance with the status of the next bank.

RXINI shall always be cleared before clearing FIFOCON.

The RWALL bit is set by hardware when the current bank is not empty, i.e. the software can read further data from the FIFO.

**Figure 30-25.** Example of an IN Pipe with 1 Data Bank

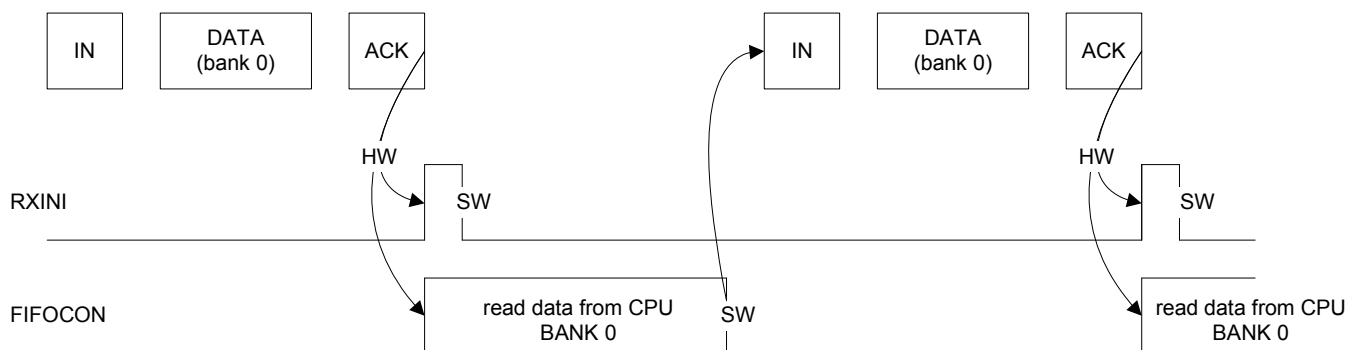

**Figure 30-26.** Example of an IN Pipe with 2 Data Banks

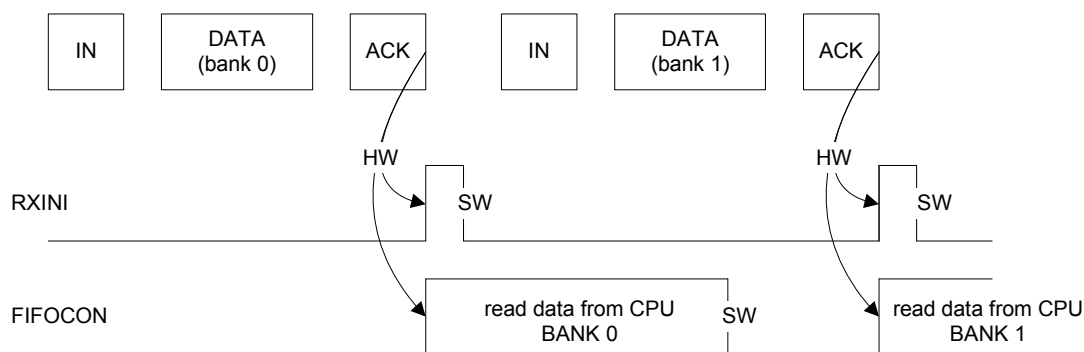

### 30.7.3.11 Management of OUT Pipes

OUT packets are sent by the host. All the data can be written by the firmware which acknowledges or not the bank when it is full.

The pipe must be configured and unfrozen first.

The TXOUTI bit is set by hardware at the same time as FIFOCON when the current bank is free. This triggers a PXINT interrupt if TXOUTE = 1.

TXOUTI shall be cleared by software (by setting the TXOUTIC bit) to acknowledge the interrupt, what has no effect on the pipe FIFO.

The firmware then writes into the FIFO and clears the FIFOCON bit to allow the USB controller to send the data. If the OUT pipe is composed of multiple banks, this also switches to the next bank. The TXOUTI and FIFOCON bits are updated by hardware in accordance with the status of the next bank.

TXOUTI shall always be cleared before clearing FIFOCON.

The RWALL bit is set by hardware when the current bank is not full, i.e. the software can write further data into the FIFO.

Note that if the firmware decides to switch to the Suspend state (by clearing the SOFE bit) while a bank is ready to be sent, the USB controller automatically exits this state and the bank is sent.

**Figure 30-27.** Example of an OUT Pipe with 1 Data Bank

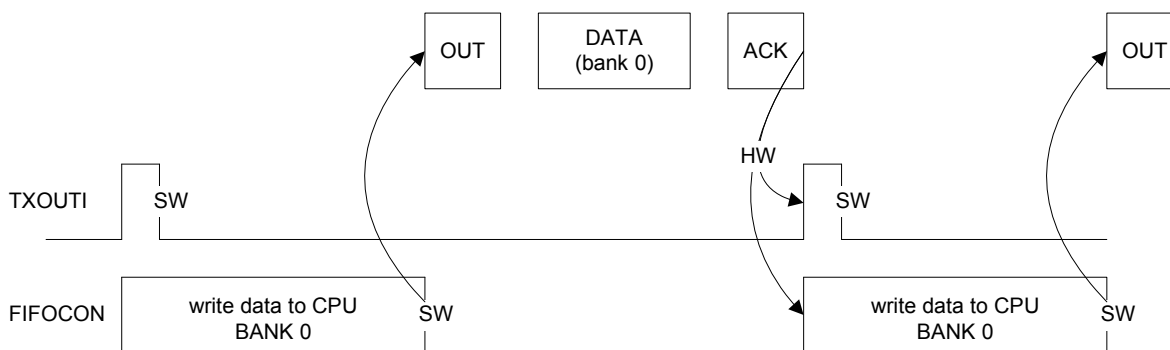

**Figure 30-28.** Example of an OUT Pipe with 2 Data Banks and no Bank Switching Delay

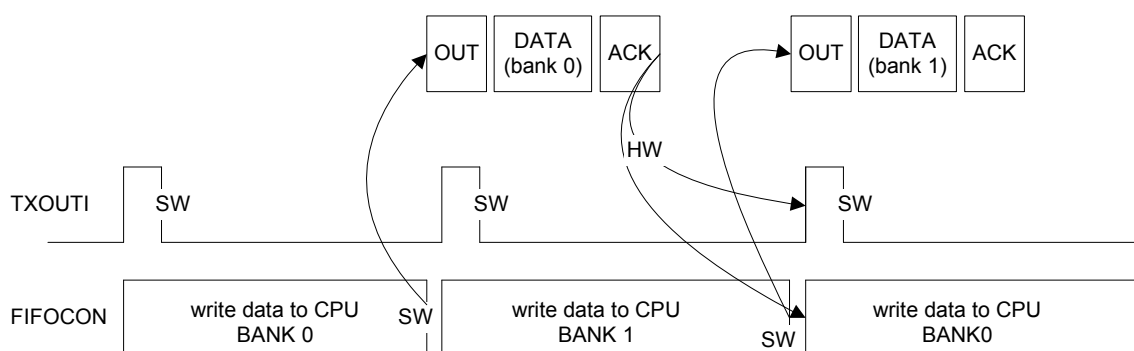

**Figure 30-29.** Example of an OUT Pipe with 2 Data Banks and a Bank Switching Delay

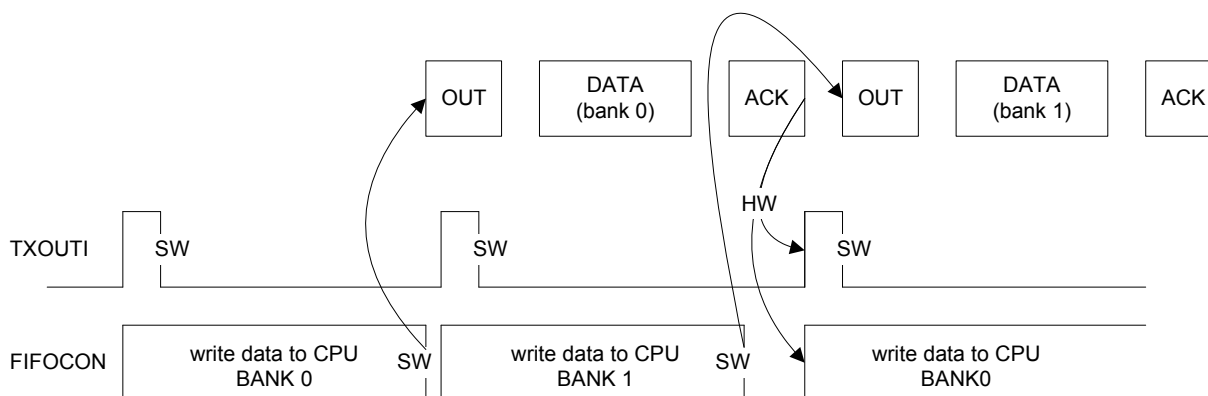

### 30.7.3.12 CRC Error

This error exists only for isochronous IN pipes. It raises the CRC Error interrupt (CRCERRI), what triggers a PXINT interrupt if CRCERRE = 1.

A CRC error can occur during IN stage if the USB controller detects a corrupted received packet. The IN packet is stored in the bank as if no CRC error had occurred (RXINI is raised).

### 30.7.3.13 Interrupts

See the structure of the USB host interrupt system on [Figure 30-6 on page 504](#).

There are two kinds of host interrupts: processing, i.e. their generation is part of the normal processing, and exception, i.e. errors (not related to CPU exceptions).

#### 30.7.3.13.1 Global Interrupts

The processing host global interrupts are:

- the Device Connection interrupt (DCONNI);
- the Device Disconnection interrupt (DDISCI);
- the USB Reset Sent interrupt (RSTI);
- the Downstream Resume Sent interrupt (RSMEDI);
- the Upstream Resume Received interrupt (RXRSMI);
- the Host Start of Frame interrupt (HSOFI);
- the Host Wake-Up interrupt (HWUPI);
- the Pipe X interrupt (PXINT);
- the DMA Channel X interrupt (DMAXINT).

There is no exception host global interrupt.

#### 30.7.3.13.2 Pipe Interrupts

The processing host pipe interrupts are:

- the Received IN Data interrupt (RXINI);
- the Transmitted OUT Data interrupt (TXOUTI);
- the Transmitted SETUP interrupt (TXSTPI);
- the Short Packet interrupt (SHORTPACKETI);
- the Number of Busy Banks interrupt (NBUSYBK).

The exception host pipe interrupts are:

- the Underflow interrupt (UNDERFI);
- the Pipe Error interrupt (PERRI);
- the NAKed interrupt (NAKEDI);
- the Overflow interrupt (OVERFI);
- the Received STALLED interrupt (RXSTALLDI);
- the CRC Error interrupt (CRCERRI).

#### 30.7.3.13.3 DMA Interrupts

The processing host DMA interrupts are:

- the End of USB Transfer Status interrupt (EOT\_STA);
- the End of Channel Buffer Status interrupt (EOCH\_BUFF\_STA);
- the Descriptor Loaded Status interrupt (DESC\_LD\_STA).

There is no exception host DMA interrupt.



### 30.7.4 USB DMA Operation

USB packets of any length may be transferred when required by the USB controller. These transfers always feature sequential addressing. These two characteristics mean that in case of high USB controller throughput, both HSB ports will benefit from “incrementing burst of unspecified length” since the average access latency of HSB slaves can then be reduced.

The DMA uses word “incrementing burst of unspecified length” of up to 256 beats for both data transfers and channel descriptor loading. A burst may last on the HSB busses for the duration of a whole USB packet transfer, unless otherwise broken by the HSB arbitration or the HSB 1 kbyte boundary crossing.

Packet data HSB bursts may be locked on a DMA buffer basis for drastic overall HSB bus bandwidth performance boost with paged memories. This is because these memories row (or bank) changes, which are very clock-cycle consuming, will then likely not occur or occur once instead of dozens of times during a single big USB packet DMA transfer in case other HSB masters address the memory. This means up to 128 words single cycle unbroken HSB bursts for bulk pipes/endpoints and 256 words single cycle unbroken bursts for isochronous pipes/endpoints. This maximal burst length is then controlled by the lowest programmed USB pipe/endpoint size (PSIZE/EPsize) and DMA channel byte length (CH\_BYTE\_LENGTH).

The USB controller average throughput may be up to nearly 1.5 Mbyte/s. Its average access latency decreases as burst length increases due to the 0 wait-state side effect of unchanged pipe/endpoint. Word access allows reducing the HSB bandwidth required for the USB by 4 compared to native byte access. If at least 0 wait-state word burst capability is also provided by the other DMA HSB bus slaves, each of both DMA HSB busses need less than 1.1% bandwidth allocation for full USB bandwidth usage at 33 MHz, and less than 0.6% at 66 MHz.

**Figure 30-30.** Example of DMA Chained List

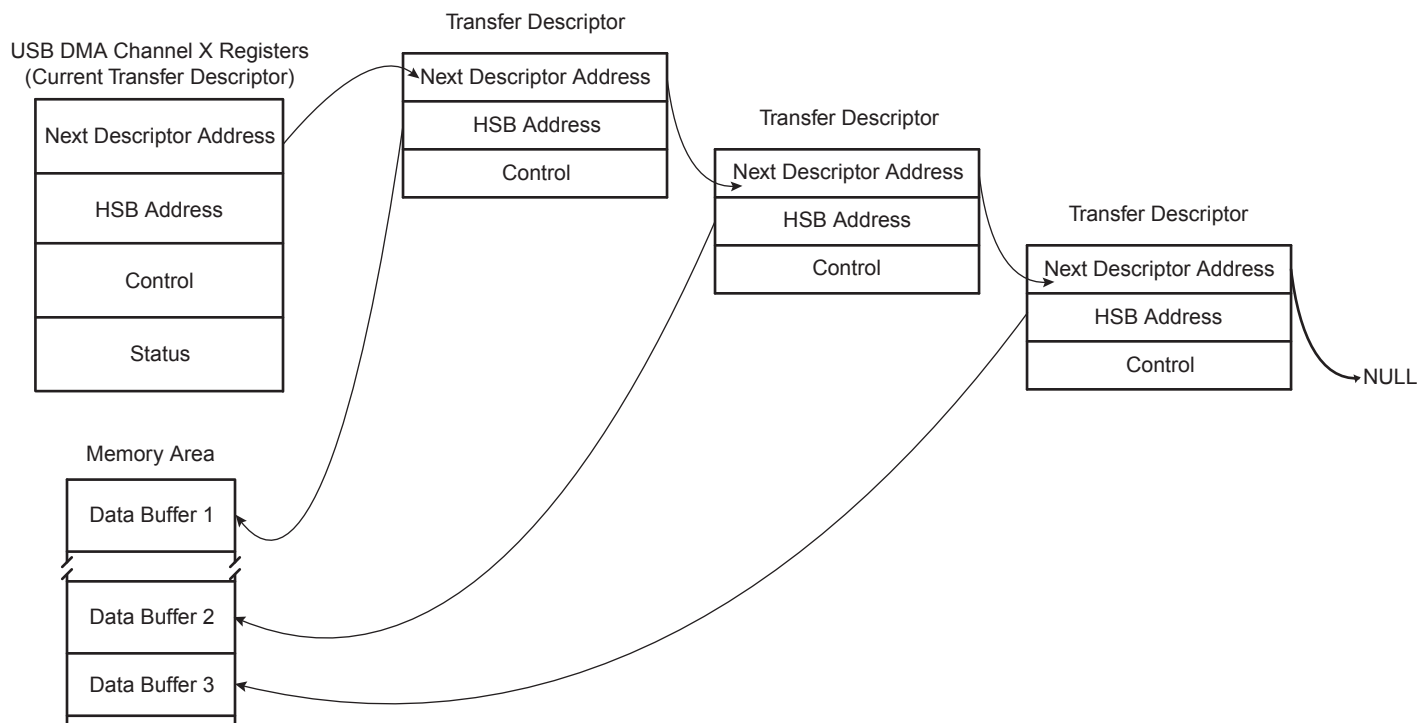

## 30.8 USB User Interface

**Table 30-5.** USB PB Memory Map

Offset	Register	Name	Access	Reset Value
0x0000	Device General Control Register	UDCON	Read/Write	0x00000100
0x0004	Device Global Interrupt Register	UDINT	Read-Only	0x00000000
0x0008	Device Global Interrupt Clear Register	UDINTCLR	Write-Only	0x00000000
0x000C	Device Global Interrupt Set Register	UDINTSET	Write-Only	0x00000000
0x0010	Device Global Interrupt Enable Register	UDINTE	Read-Only	0x00000000
0x0014	Device Global Interrupt Enable Clear Register	UDINTECLR	Write-Only	0x00000000
0x0018	Device Global Interrupt Enable Set Register	UDINTESET	Write-Only	0x00000000
0x001C	Endpoint Enable/Reset Register	UERST	Read/Write	0x00000000
0x0020	Device Frame Number Register	UDFNUM	Read-Only	0x00000000
0x0024 - 0x00FC	Reserved	–	–	–
0x0100	Endpoint 0 Configuration Register	UECFG0	Read/Write	0x00000000
0x0104	Endpoint 1 Configuration Register	UECFG1	Read/Write	0x00000000
0x0108	Endpoint 2 Configuration Register	UECFG2	Read/Write	0x00000000
0x010C	Endpoint 3 Configuration Register	UECFG3	Read/Write	0x00000000
0x0110	Endpoint 4 Configuration Register	UECFG4	Read/Write	0x00000000
0x0114	Endpoint 5 Configuration Register	UECFG5	Read/Write	0x00000000
0x0118	Endpoint 6 Configuration Register	UECFG6	Read/Write	0x00000000
+0x004 - 0x012C	Reserved	–	–	–
0x0130	Endpoint 0 Status Register	UESTA0	Read-Only	0x00000100
0x0134	Endpoint 1 Status Register	UESTA1	Read-Only	0x00000100
0x0138	Endpoint 2 Status Register	UESTA2	Read-Only	0x00000100
0x013C	Endpoint 3 Status Register	UESTA3	Read-Only	0x00000100
0x0140	Endpoint 4 Status Register	UESTA4	Read-Only	0x00000100
0x0144	Endpoint 5 Status Register	UESTA5	Read-Only	0x00000100
0x0148	Endpoint 6 Status Register	UESTA6	Read-Only	0x00000100
+0x004 - 0x015C	Reserved	–	–	–
0x0160	Endpoint 0 Status Clear Register	UESTA0CLR	Write-Only	0x00000000
0x0164	Endpoint 1 Status Clear Register	UESTA1CLR	Write-Only	0x00000000
0x0168	Endpoint 2 Status Clear Register	UESTA2CLR	Write-Only	0x00000000
0x016C	Endpoint 3 Status Clear Register	UESTA3CLR	Write-Only	0x00000000
0x0170	Endpoint 4 Status Clear Register	UESTA4CLR	Write-Only	0x00000000
0x0174	Endpoint 5 Status Clear Register	UESTA5CLR	Write-Only	0x00000000
0x0178	Endpoint 6 Status Clear Register	UESTA6CLR	Write-Only	0x00000000
+0x04 - 0x018C	Reserved	–	–	–
0x0190	Endpoint 0 Status Set Register	UESTA0SET	Write-Only	0x00000000

**Table 30-5. USB PB Memory Map**

Offset	Register	Name	Access	Reset Value
0x0194	Endpoint 1 Status Set Register	UESTA1SET	Write-Only	0x00000000
0x0198	Endpoint 2 Status Set Register	UESTA2SET	Write-Only	0x00000000
0x019C	Endpoint 3 Status Set Register	UESTA3SET	Write-Only	0x00000000
0x01A0	Endpoint 4 Status Set Register	UESTA4SET	Write-Only	0x00000000
0x01A4	Endpoint 5 Status Set Register	UESTA5SET	Write-Only	0x00000000
0x01A8	Endpoint 6 Status Set Register	UESTA6SET	Write-Only	0x00000000
+0x04 - 0x01BC	Reserved	–	–	–
0x01C0	Endpoint 0 Control Register	UECON0	Read-Only	0x00000000
0x01C4	Endpoint 1 Control Register	UECON1	Read-Only	0x00000000
0x01C8	Endpoint 2 Control Register	UECON2	Read-Only	0x00000000
0x01CC	Endpoint 3 Control Register	UECON3	Read-Only	0x00000000
0x01D0	Endpoint 4 Control Register	UECON4	Read-Only	0x00000000
0x01D4	Endpoint 5 Control Register	UECON5	Read-Only	0x00000000
0x01D8	Endpoint 6 Control Register	UECON6	Read-Only	0x00000000
+0x04 - 0x01EC	Reserved	–	–	–
0x01F0	Endpoint 0 Control Set Register	UECON0SET	Write-Only	0x00000000
0x01F4	Endpoint 1 Control Set Register	UECON1SET	Write-Only	0x00000000
0x01F8	Endpoint 2 Control Set Register	UECON2SET	Write-Only	0x00000000
0x01FC	Endpoint 3 Control Set Register	UECON3SET	Write-Only	0x00000000
0x0200	Endpoint 4 Control Set Register	UECON4SET	Write-Only	0x00000000
0x0204	Endpoint 5 Control Set Register	UECON5SET	Write-Only	0x00000000
0x0208	Endpoint 6 Control Set Register	UECON6SET	Write-Only	0x00000000
+0x04 - 0x021C	Reserved	–	–	–
0x0220	Endpoint 0 Control Clear Register	UECON0CLR	Write-Only	0x00000000
0x0224	Endpoint 1 Control Clear Register	UECON1CLR	Write-Only	0x00000000
0x0228	Endpoint 2 Control Clear Register	UECON2CLR	Write-Only	0x00000000
0x022C	Endpoint 3 Control Clear Register	UECON3CLR	Write-Only	0x00000000
0x0230	Endpoint 4 Control Clear Register	UECON4CLR	Write-Only	0x00000000
0x0234	Endpoint 5 Control Clear Register	UECON5CLR	Write-Only	0x00000000
0x0238	Endpoint 6 Control Clear Register	UECON6CLR	Write-Only	0x00000000
+0x04 - 0x030C	Reserved	–	–	–
0x0310	Device DMA Channel 1 Next Descriptor Address Register	UDDMA1_NEXTDESC	Read/Write	0x00000000
0x0314	Device DMA Channel 1 HSB Address Register	UDDMA1_ADDR	Read/Write	0x00000000
0x0318	Device DMA Channel 1 Control Register	UDDMA1_CONTROL	Read/Write	0x00000000

**Table 30-5.** USB PB Memory Map

Offset	Register	Name	Access	Reset Value
0x031C	Device DMA Channel 1 Status Register	UDDMA1_ STATUS	Read/Write	0x00000000
0x0320	Device DMA Channel 2 Next Descriptor Address Register	UDDMA2_ NEXTDESC	Read/Write	0x00000000
0x0324	Device DMA Channel 2 HSB Address Register	UDDMA2_ ADDR	Read/Write	0x00000000
0x0328	Device DMA Channel 2 Control Register	UDDMA2_ CONTROL	Read/Write	0x00000000
0x032C	Device DMA Channel 2 Status Register	UDDMA2_ STATUS	Read/Write	0x00000000
0x0330	Device DMA Channel 3 Next Descriptor Address Register	UDDMA3_ NEXTDESC	Read/Write	0x00000000
0x0334	Device DMA Channel 3 HSB Address Register	UDDMA3_ ADDR	Read/Write	0x00000000
0x0338	Device DMA Channel 3 Control Register	UDDMA3_ CONTROL	Read/Write	0x00000000
0x033C	Device DMA Channel 3 Status Register	UDDMA3_ STATUS	Read/Write	0x00000000
0x0340	Device DMA Channel 4 Next Descriptor Address Register	UDDMA4_ NEXTDESC	Read/Write	0x00000000
0x0344	Device DMA Channel 4 HSB Address Register	UDDMA4_ ADDR	Read/Write	0x00000000
0x0348	Device DMA Channel 4 Control Register	UDDMA4_ CONTROL	Read/Write	0x00000000
0x034C	Device DMA Channel 4 Status Register	UDDMA4_ STATUS	Read/Write	0x00000000
0x0350	Device DMA Channel 5 Next Descriptor Address Register	UDDMA5_ NEXTDESC	Read/Write	0x00000000
0x0354	Device DMA Channel 5 HSB Address Register	UDDMA5_ ADDR	Read/Write	0x00000000
0x0358	Device DMA Channel 5 Control Register	UDDMA5_ CONTROL	Read/Write	0x00000000
0x035C	Device DMA Channel 5 Status Register	UDDMA5_ STATUS	Read/Write	0x00000000
0x0360	Device DMA Channel 6 Next Descriptor Address Register	UDDMA6_ NEXTDESC	Read/Write	0x00000000
0x0364	Device DMA Channel 6 HSB Address Register	UDDMA6_ ADDR	Read/Write	0x00000000
0x0368	Device DMA Channel 6 Control Register	UDDMA6_ CONTROL	Read/Write	0x00000000
0x036C	Device DMA Channel 6 Status Register	UDDMA6_ STATUS	Read/Write	0x00000000
0x0370 - 0x03FC	Reserved	–	–	–

**Table 30-5. USB PB Memory Map**

Offset	Register	Name	Access	Reset Value
0x0400	Host General Control Register	UHCON	Read/Write	0x00000000
0x0404	Host Global Interrupt Register	UHINT	Read-Only	0x00000000
0x0408	Host Global Interrupt Clear Register	UHINTCLR	Write-Only	0x00000000
0x040C	Host Global Interrupt Set Register	UHINTSET	Write-Only	0x00000000
0x0410	Host Global Interrupt Enable Register	UHINTE	Read-Only	0x00000000
0x0414	Host Global Interrupt Enable Clear Register	UHINTECLR	Write-Only	0x00000000
0x0418	Host Global Interrupt Enable Set Register	UHINTESET	Write-Only	0x00000000
0x0041C	Pipe Enable/Reset Register	UPRST	Read/Write	0x00000000
0x0420	Host Frame Number Register	UHFNUM	Read/Write	0x00000000
0x0424	Host Address 1 Register	UHADDR1	Read/Write	0x00000000
0x0428	Host Address 2 Register	UHADDR2	Read/Write	0x00000000
+0x04 - 0x04FC	Reserved	–	–	–
0x0500	Pipe 0 Configuration Register	UPCFG0	Read/Write	0x00000000
0x0504	Pipe 1 Configuration Register	UPCFG1	Read/Write	0x00000000
0x0508	Pipe 2 Configuration Register	UPCFG2	Read/Write	0x00000000
0x050C	Pipe 3 Configuration Register	UPCFG3	Read/Write	0x00000000
0x0510	Pipe 4 Configuration Register	UPCFG4	Read/Write	0x00000000
0x0514	Pipe 5 Configuration Register	UPCFG5	Read/Write	0x00000000
0x0518	Pipe 6 Configuration Register	UPCFG6	Read/Write	0x00000000
+0x04 - 0x052C	Reserved	–	–	–
0x0530	Pipe 0 Status Register	UPSTA0	Read-Only	0x00000000
0x0534	Pipe 1 Status Register	UPSTA1	Read-Only	0x00000000
0x0538	Pipe 2 Status Register	UPSTA2	Read-Only	0x00000000
0x053C	Pipe 3 Status Register	UPSTA3	Read-Only	0x00000000
0x0540	Pipe 4 Status Register	UPSTA4	Read-Only	0x00000000
0x0544	Pipe 5 Status Register	UPSTA5	Read-Only	0x00000000
0x0548	Pipe 6 Status Register	UPSTA6	Read-Only	0x00000000
+0x04 - 0x055C	Reserved	–	–	–
0x0560	Pipe 0 Status Clear Register	UPSTA0CLR	Write-Only	0x00000000
0x0564	Pipe 1 Status Clear Register	UPSTA1CLR	Write-Only	0x00000000
0x0568	Pipe 2 Status Clear Register	UPSTA2CLR	Write-Only	0x00000000
0x056C	Pipe 3 Status Clear Register	UPSTA3CLR	Write-Only	0x00000000
0x0570	Pipe 4 Status Clear Register	UPSTA4CLR	Write-Only	0x00000000
0x0574	Pipe 5 Status Clear Register	UPSTA5CLR	Write-Only	0x00000000
0x0578	Pipe 6 Status Clear Register	UPSTA6CLR	Write-Only	0x00000000
+0x04 - 0x058C	Reserved	–	–	–



**Table 30-5. USB PB Memory Map**

Offset	Register	Name	Access	Reset Value
0x0590	Pipe 0 Status Set Register	UPSTA0SET	Write-Only	0x00000000
0x0594	Pipe 1 Status Set Register	UPSTA1SET	Write-Only	0x00000000
0x0598	Pipe 2 Status Set Register	UPSTA2SET	Write-Only	0x00000000
0x059C	Pipe 3 Status Set Register	UPSTA3SET	Write-Only	0x00000000
0x05A0	Pipe 4 Status Set Register	UPSTA4SET	Write-Only	0x00000000
0x05A4	Pipe 5 Status Set Register	UPSTA5SET	Write-Only	0x00000000
0x05A8	Pipe 6 Status Set Register	UPSTA6SET	Write-Only	0x00000000
+0x04 - 0x05BC	Reserved	–	–	–
0x05C0	Pipe 0 Control Register	UPCON0	Read-Only	0x00000000
0x05C4	Pipe 1 Control Register	UPCON1	Read-Only	0x00000000
0x05C8	Pipe 2 Control Register	UPCON2	Read-Only	0x00000000
0x05CC	Pipe 3 Control Register	UPCON3	Read-Only	0x00000000
0x05D0	Pipe 4 Control Register	UPCON4	Read-Only	0x00000000
0x05D4	Pipe 5 Control Register	UPCON5	Read-Only	0x00000000
0x05D8	Pipe 6 Control Register	UPCON6	Read-Only	0x00000000
+0x04 - 0x05EC	Reserved	–	–	–
0x05F0	Pipe 0 Control Set Register	UPCON0SET	Write-Only	0x00000000
0x05F4	Pipe 1 Control Set Register	UPCON1SET	Write-Only	0x00000000
0x05F8	Pipe 2 Control Set Register	UPCON2SET	Write-Only	0x00000000
0x05FC	Pipe 3 Control Set Register	UPCON3SET	Write-Only	0x00000000
0x0600	Pipe 4 Control Set Register	UPCON4SET	Write-Only	0x00000000
0x0604	Pipe 5 Control Set Register	UPCON5SET	Write-Only	0x00000000
0x0608	Pipe 6 Control Set Register	UPCON6SET	Write-Only	0x00000000
+0x04 - 0x061C	Reserved	–	–	–
0x0620	Pipe 0 Control Clear Register	UPCON0CLR	Write-Only	0x00000000
0x0624	Pipe 1 Control Clear Register	UPCON1CLR	Write-Only	0x00000000
0x0628	Pipe 2 Control Clear Register	UPCON2CLR	Write-Only	0x00000000
0x062C	Pipe 3 Control Clear Register	UPCON3CLR	Write-Only	0x00000000
0x0630	Pipe 4 Control Clear Register	UPCON4CLR	Write-Only	0x00000000
0x0634	Pipe 5 Control Clear Register	UPCON5CLR	Write-Only	0x00000000
0x0638	Pipe 6 Control Clear Register	UPCON6CLR	Write-Only	0x00000000
+0x04 - 0x064C	Reserved	–	–	–
0x0650	Pipe 0 IN Request Register	UPINRQ0	Read/Write	0x00000000
0x0654	Pipe 1 IN Request Register	UPINRQ1	Read/Write	0x00000000
0x0658	Pipe 2 IN Request Register	UPINRQ2	Read/Write	0x00000000
0x065C	Pipe 3 IN Request Register	UPINRQ3	Read/Write	0x00000000



**Table 30-5. USB PB Memory Map**

Offset	Register	Name	Access	Reset Value
0x0660	Pipe 4 IN Request Register	UPINRQ4	Read/Write	0x00000000
0x0664	Pipe 5 IN Request Register	UPINRQ5	Read/Write	0x00000000
0x0668	Pipe 6 IN Request Register	UPINRQ6	Read/Write	0x00000000
0x066C - 0x067C	Reserved	–	–	–
0x0680	Pipe 0 Error Register	UPERR0	Read/Write	0x00000000
0x0684	Pipe 1 Error Register	UPERR1	Read/Write	0x00000000
0x0688	Pipe 2 Error Register	UPERR2	Read/Write	0x00000000
0x068C	Pipe 3 Error Register	UPERR3	Read/Write	0x00000000
0x0690	Pipe 4 Error Register	UPERR4	Read/Write	0x00000000
0x0694	Pipe 5 Error Register	UPERR5	Read/Write	0x00000000
0x0698	Pipe 6 Error Register	UPERR6	Read/Write	0x00000000
+0x04 - 0x070C	Reserved	–	–	–
0x0710	Host DMA Channel 1 Next Descriptor Address Register	UHDMA1_ NEXTDESC	Read/Write	0x00000000
0x0714	Host DMA Channel 1 HSB Address Register	UHDMA1_ ADDR	Read/Write	0x00000000
0x0718	Host DMA Channel 1 Control Register	UHDMA1_ CONTROL	Read/Write	0x00000000
0x071C	Host DMA Channel 1 Status Register	UHDMA1_ STATUS	Read/Write	0x00000000
0x0720	Host DMA Channel 2 Next Descriptor Address Register	UHDMA2_ NEXTDESC	Read/Write	0x00000000
0x0724	Host DMA Channel 2 HSB Address Register	UHDMA2_ ADDR	Read/Write	0x00000000
0x0728	Host DMA Channel 2 Control Register	UHDMA2_ CONTROL	Read/Write	0x00000000
0x072C	Host DMA Channel 2 Status Register	UHDMA2_ STATUS	Read/Write	0x00000000
0x0730	Host DMA Channel 3 Next Descriptor Address Register	UHDMA3_ NEXTDESC	Read/Write	0x00000000
0x0734	Host DMA Channel 3 HSB Address Register	UHDMA3_ ADDR	Read/Write	0x00000000
0x0738	Host DMA Channel 3 Control Register	UHDMA3_ CONTROL	Read/Write	0x00000000
0x073C	Host DMA Channel 3 Status Register	UHDMA3_ STATUS	Read/Write	0x00000000
0x0740	Host DMA Channel 4 Next Descriptor Address Register	UHDMA4_ NEXTDESC	Read/Write	0x00000000
0x0744	Host DMA Channel 4 HSB Address Register	UHDMA4_ ADDR	Read/Write	0x00000000

**Table 30-5. USB PB Memory Map**

Offset	Register	Name	Access	Reset Value
0x0748	Host DMA Channel 4 Control Register	UHDMA4_ CONTROL	Read/Write	0x00000000
0x074C	Host DMA Channel 4 Status Register	UHDMA4_ STATUS	Read/Write	0x00000000
0x0750	Host DMA Channel 5 Next Descriptor Address Register	UHDMA5_ NEXTDESC	Read/Write	0x00000000
0x0754	Host DMA Channel 5 HSB Address Register	UHDMA5_ ADDR	Read/Write	0x00000000
0x0758	Host DMA Channel 5 Control Register	UHDMA5_ CONTROL	Read/Write	0x00000000
0x075C	Host DMA Channel 5 Status Register	UHDMA5_ STATUS	Read/Write	0x00000000
0x0760	Host DMA Channel 6 Next Descriptor Address Register	UHDMA6_ NEXTDESC	Read/Write	0x00000000
0x0764	Host DMA Channel 6 HSB Address Register	UHDMA6_ ADDR	Read/Write	0x00000000
0x0768	Host DMA Channel 6 Control Register	UHDMA6_ CONTROL	Read/Write	0x00000000
0x076C	Host DMA Channel 6 Status Register	UHDMA6_ STATUS	Read/Write	0x00000000
0x0770 - 0x07FC	Reserved	-	-	-
0x0800	General Control Register	USBCON	Read/Write	0x03004000
0x0804	General Status Register	USBSTA	Read-Only	0x00000400
0x0808	General Status Clear Register	USBSTACL	Write-Only	0x00000000
0x080C	General Status Set Register	USBSTASET	Write-Only	0x00000000
0x0810-0x0814	Reserved	-	-	-
0x0818	IP Version Register	UVERS	Read-Only	0x00000311
0x081C	IP Features Register	UFEATURES	Read-Only	0x00012467
0x0820	IP PB Address Size Register	UADDRSIZE	Read-Only	0x00001000
0x0824	IP Name Register 1	UNAME1	Read-Only	0x48555342 ("HUSB")
0x0828	IP Name Register 2	UNAME2	Read-Only	0x004F5447 ("\00TG")
0x082C	USB Finite State Machine Status Register	USBFSM	Read-Only	0x00000009
0x0830 - 0x0BFC	Reserved	-	-	-



**Table 30-6.** USB HSB Memory Map

Offset	Register	Name	Access	Reset Value
0x00000 - 0x0FFFC	Pipe/Endpoint 0 FIFO Data Register	USB_FIF00_DATA	Read/Write	Undefined
0x10000 - 0x1FFFC	Pipe/Endpoint 1 FIFO Data Register	USB_FIF01_DATA	Read/Write	Undefined
0x20000 - 0x2FFFC	Pipe/Endpoint 2 FIFO Data Register	USB_FIF02_DATA	Read/Write	Undefined
0x30000 - 0x3FFFC	Pipe/Endpoint 3 FIFO Data Register	USB_FIF03_DATA	Read/Write	Undefined
0x40000 - 0x4FFFC	Pipe/Endpoint 4 FIFO Data Register	USB_FIF04_DATA	Read/Write	Undefined
0x50000 - 0x5FFFC	Pipe/Endpoint 5 FIFO Data Register	USB_FIF05_DATA	Read/Write	Undefined
0x60000 - 0x6FFFC	Pipe/Endpoint 6 FIFO Data Register	USB_FIF06_DATA	Read/Write	Undefined
+0x00004 - 0xFFFFC	Reserved	–	–	–

In the following subsections, the bit and bit-field access types use the following flags:

- “r”: readable;
- “w”: writable;
- “u”: may be updated by hardware.

## 30.8.1 USB General Registers

### 30.8.1.1 USB General Control Register (USBCON)

**Offset:** 0x0800  
**Register Name:** USBCON  
**Access Type:** Read/Write  
**Reset Value:** 0x03004000

31	30	29	28	27	26	25	24
-	-	-	-	-	-	UIMOD	UIDE
						rw	rw
						1	1
23	22	21	20	19	18	17	16
-	UNLOCK	TIMPAGE		-	-	TIMVALUE	
	rw	rw				rw	
	0	0		0		0	0
15	14	13	12	11	10	9	8
USBE	FRZCLK	VBUSPO	OTGPADE	HNPREQ	SRPREQ	SRPSEL	VBUSHWC
rw	rw	rw	rw	rwu	rwu	rw	rw
0	1	0	0	0	0	0	0
7	6	5	4	3	2	1	0
STOE	HNPERR	ROLEEXE	BCERR	VBERRE	SRPE	VBUSTE	IDTE
rw	rw	rw	rw	rw	rw	rw	rw
0	0	0	0	0	0	0	0

- **IDTE: ID Transition Interrupt Enable**

Set to enable the ID Transition interrupt (IDTI).

Clear to disable the ID Transition interrupt (IDTI).

- **VBUSTE: VBus Transition Interrupt Enable**

Set to enable the VBus Transition interrupt (VBUSTI).

Clear to disable the VBus Transition interrupt (VBUSTI).

- **SRPE: SRP Interrupt Enable**

Set to enable the SRP interrupt (SRPI).

Clear to disable the SRP interrupt (SRPI).

- **VBERRE: VBus Error Interrupt Enable**

Set to enable the VBus Error interrupt (VBERRI).

Clear to disable the VBus Error interrupt (VBERRI).

- **BCERR**: B-Connection Error Interrupt Enable

Set to enable the B-Connection Error interrupt (BCERRI).

Clear to disable the B-Connection Error interrupt (BCERRI).

- **ROLEEXE: Role Exchange Interrupt Enable**

Set to enable the Role Exchange interrupt (ROLEEXI).

Clear to disable the Role Exchange interrupt (ROLEEXI).

- **HNPERRI: HNP Error Interrupt Enable**

Set to enable the HNP Error interrupt (HNPERRI).

Clear to disable the HNP Error interrupt (HNPERRI).

- **STOE: Suspend Time-Out Interrupt Enable**

Set to enable the Suspend Time-Out interrupt (STOI).

Clear to disable the Suspend Time-Out interrupt (STOI).

- **VBUSHWC: VBus Hardware Control**

Set to disable the hardware control over the USB\_VBOF output pin.

Clear to enable the hardware control over the USB\_VBOF output pin.

If cleared, then the USB macro considers VBus problems and resets the USB\_VBOF output pin in that event.

- **SRPSEL: SRP Selection**

Set to choose VBus pulsing as SRP method.

Clear to choose data line pulsing as SRP method.

- **SRPREQ: SRP Request**

Set to initiate an SRP when the controller is in device mode.

Cleared by hardware when the controller is initiating an SRP.

- **HNPREQ: HNP Request**

When the controller is in device mode:

Set to initiate an HNP.

Cleared by hardware when the controller is initiating an HNP.

When the controller is in host mode:

Set to accept an HNP.

Clear otherwise.

- **OTGPADE: OTG Pad Enable**

Set to enable the OTG pad.

Clear to disable the OTG pad.

Note that this bit can be set/cleared even if USBE = 0 or FRZCLK = 1. Disabling the USB controller (by clearing the USBE bit) does not reset this bit.

- **VBUSPO: VBus Polarity**

When 0, the USB\_VBOF output signal is in its default mode (active high).

When 1, the USB\_VBOF output signal is inverted (active low).

To be generic. May be useful to control an external VBus power module.

Note that this bit can be set/cleared even if USBE = 0 or FRZCLK = 1. Disabling the USB controller (by clearing the USBE bit) does not reset this bit.

- **FRZCLK: Freeze USB Clock**

Set to disable the clock inputs (the resume detection is still active). This reduces power consumption. Unless explicitly stated, all registers then become read-only.

Clear to enable the clock inputs.

Note that this bit can be set/cleared even if USBE = 0 or FRZCLK = 1. Disabling the USB controller (by clearing the USBE bit) does not reset this bit, but this freezes the clock inputs whatever its value.

- **USBE: USB Macro Enable**

Set to enable the USB controller.

Clear to disable and reset the USB controller, to disable the USB transceiver and to disable the USB controller clock inputs. Unless explicitly stated, all registers then become read-only and are reset.

Note that this bit can be set/cleared even if USBE = 0 or FRZCLK = 1.

- **TIMVALUE: Timer Value**

Set to initialize the new value of the special timer register selected by TIMPAGE.

- **TIMPAGE: Timer Page**

Write the page value to access a special timer register.

- **UNLOCK: Timer Access Unlock**

Set to unlock the TIMPAGE and TIMVALUE fields before writing them.

Reset to lock the TIMPAGE and TIMVALUE fields.

Note that the TIMPAGE and TIMVALUE fields can always be read, whatever the value of UNLOCK.

- **UIDE: USB\_ID Pin Enable**

Set to select the USB mode (device/host) from the USB\_ID input pin.

Clear to select the USB mode (device/host) with the UIMOD bit.

Note that this bit can be set/cleared even if USBE = 0 or FRZCLK = 1. Disabling the USB controller (by clearing the USBE bit) does not reset this bit.

- **UIMOD: USB Macro Mode**

This bit has no effect when UIDE = 1 (USB\_ID input pin activated).

Set to select the USB device mode.

Clear to select the USB host mode.

Note that this bit can be set/cleared even if USBE = 0 or FRZCLK = 1. Disabling the USB controller (by clearing the USBE bit) does not reset this bit.



- **VBERRI: VBus Error Interrupt Flag**

In host mode, set by hardware when a VBus drop has been detected. This triggers a USB interrupt if VBERRE = 1.

Shall be cleared by software (by setting the VBERRIC bit) to acknowledge the interrupt.

Note that if a VBus problem occurs, then the VBERRI interrupt is generated even if the USB macro does not go to an error state because of VBUSHWC = 1.

- **BCERRI: B-Connection Error Interrupt Flag**

In host mode, set by hardware when an error occurs during the B-connection. This triggers a USB interrupt if BCERRE = 1.

Shall be cleared by software (by setting the BCERRIC bit) to acknowledge the interrupt.

- **ROLEEXI: Role Exchange Interrupt Flag**

Set by hardware when the USB controller has successfully switched its mode because of an HNP negotiation (host to device or device to host). This triggers a USB interrupt if ROLEEXE = 1.

Shall be cleared by software (by setting the ROLEEXIC bit) to acknowledge the interrupt.

- **HNPERRI: HNP Error Interrupt Flag**

In device mode, set by hardware when an error has been detected during an HNP negotiation. This triggers a USB interrupt if HNPERRI = 1.

Shall be cleared by software (by setting the HNPERRIC bit) to acknowledge the interrupt.

- **STOI: Suspend Time-Out Interrupt Flag**

In host mode, set by hardware when a time-out error (more than 200ms) has been detected after a suspend. This triggers a USB interrupt if STOE = 1.

Shall be cleared by software (by setting the STOIC bit) to acknowledge the interrupt.

- **VBUSRQ: VBus Request**

In host mode, set by software (by setting the VBUSRQS bit) to assert the USB\_VBOF output pin in order to enable the VBus power supply generation.

Cleared by software by setting the VBUSRQC bit.

Cleared by hardware when a VBus error occurs when VBUSHWC = 0.

- **ID: USB\_ID Pin State**

Set/cleared by hardware and reflects the state of the USB\_ID input pin, even if USBE = 0.

- **VBUS: VBus Level**

Set/cleared by hardware and reflects the level of the VBus line, even if USBE = 0.

This bit can be used in device mode to monitor the USB bus connection state of the application.

- **SPEED: Speed Status**

Set by hardware according to the controller speed mode:

SPEED		Speed Status
0	0	FULL-SPEED mode
1	0	LOW-SPEED mode
X	1	Reserved

Shall only be used in host mode.

## 30.8.1.3 USB General Status Clear Register (USBSTACL R)

**Offset:** 0x0808  
**Register Name:** USBSTACL R  
**Access Type:** Write-Only  
**Read Value:** 0x00000000

31	30	29	28	27	26	25	24
–	–	–	–	–	–	–	–
23	22	21	20	19	18	17	16
–	–	–	–	–	–	–	–
15	14	13	12	11	10	9	8
–	–	–	–	–	–	VBUSRQC	–
						w	
						0	
7	6	5	4	3	2	1	0
STOIC	HNPERRIC	ROLEEXIC	BCERRIC	VBERRIC	SRPIC	VBUSTIC	IDTIC
w	w	w	w	w	w	w	w
0	0	0	0	0	0	0	0

- **IDTIC: ID Transition Interrupt Flag Clear**

Set to clear IDTI.

Clearing has no effect.

Always read as 0.

- **VBUSTIC: VBus Transition Interrupt Flag Clear**

Set to clear VBUSTI.

Clearing has no effect.

Always read as 0.

- **SRPIC: SRP Interrupt Flag Clear**

Set to clear SRPI.

Clearing has no effect.

Always read as 0.

- **VBERRIC: VBus Error Interrupt Flag Clear**

Set to clear VBERRI.

Clearing has no effect.

Always read as 0.

- **BCERRIC: B-Connection Error Interrupt Flag Clear**

Set to clear BCERRI.

Clearing has no effect.

Always read as 0.

- **ROLEEXIC: Role Exchange Interrupt Flag Clear**

Set to clear ROLEEXI.

Clearing has no effect.

Always read as 0.

- **HNPERRIC: HNP Error Interrupt Flag Clear**

Set to clear HNPERRI.

Clearing has no effect.

Always read as 0.

- **STOIC: Suspend Time-Out Interrupt Flag Clear**

Set to clear STOI.

Clearing has no effect.

Always read as 0.

- **VBUSRQC: VBus Request Clear**

Set to clear VBUSRQ.

Clearing has no effect.

Always read as 0.



## 30.8.1.4 USB General Status Set Register (USBSTASET)

**Offset:** 0x080C  
**Register Name:** USBSTASET  
**Access Type:** Write-Only  
**Read Value:** 0x00000000

31	30	29	28	27	26	25	24
-	-	-	-	-	-	-	-
23	22	21	20	19	18	17	16
-	-	-	-	-	-	-	-
15	14	13	12	11	10	9	8
-	-	-	-	-	-	VBUSRQS	-
						w	
						0	
7	6	5	4	3	2	1	0
STOIS	HNPERRIS	ROLEEXIS	BCERRIS	VBERRIS	SRPIS	VBUSTIS	IDTIS
w	w	w	w	w	w	w	w
0	0	0	0	0	0	0	0

- **IDTIS: ID Transition Interrupt Flag Set**

Set to set IDTI, what may be useful for test or debug purposes.

Clearing has no effect.

Always read as 0.

- **VBUSTIS: VBus Transition Interrupt Flag Set**

Set to set VBUSTI, what may be useful for test or debug purposes.

Clearing has no effect.

Always read as 0.

- **SRPIS: SRP Interrupt Flag Set**

Set to set SRPI, what may be useful for test or debug purposes.

Clearing has no effect.

Always read as 0.

- **VBERRIS: VBus Error Interrupt Flag Set**

Set to set VBERRI, what may be useful for test or debug purposes.

Clearing has no effect.

Always read as 0.

- **BCERRIS: B-Connection Error Interrupt Flag Set**

Set to set BCERRI, what may be useful for test or debug purposes.

Clearing has no effect.

Always read as 0.

- **ROLEEXIS: Role Exchange Interrupt Flag Set**

Set to set ROLEEXI, what may be useful for test or debug purposes.

Clearing has no effect.

Always read as 0.

- **HNPERRIS: HNP Error Interrupt Flag Set**

Set to set HNPERRI, what may be useful for test or debug purposes.

Clearing has no effect.

Always read as 0.

- **STOIS: Suspend Time-Out Interrupt Flag Set**

Set to set STOI, what may be useful for test or debug purposes.

Clearing has no effect.

Always read as 0.

- **VBUSRQS: VBus Request Set**

Set to set VBUSRQ.

Clearing has no effect.

Always read as 0.

## 30.8.1.5 USB IP Version Register (UVERS)

**Offset:** 0x0818  
**Register Name:** UVERS  
**Access Type:** Read-Only  
**Read Value:** 0x00000260

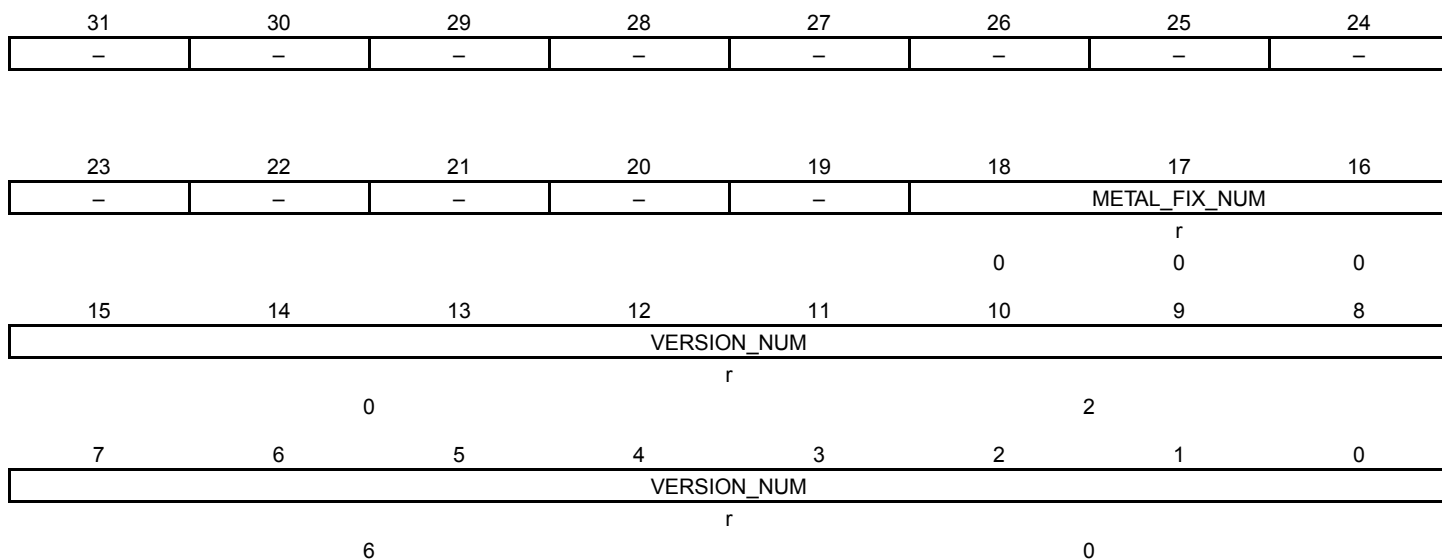

- **VERSION\_NUM: IP Version Number**

This field indicates the version number of the USB macro IP, encoded with 1 version digit per nibble, e.g. 0x0260 for version 2.6.0.

- **METAL\_FIX\_NUM: Number of Metal Fixes**

This field indicates the number of metal fixes of the USB macro IP.

## 30.8.1.6 USB IP Features Register (UFEATURES)

**Offset:** 0x081C  
**Register Name:** UFEATURES  
**Access Type:** Read-Only  
**Read Value:** 0x00012467

31	30	29	28	27	26	25	24
-	-	-	-	-	-	-	-

23	22	21	20	19	18	17	16
-	-	-	-	-	-	-	-

15	14	13	12	11	10	9	8
BYTE_WRITE_DPRAM	FIFO_MAX_SIZE			DMA_FIFO_WORD_DEPTH			

r 0 0 1 0 0 1 0 0

7	6	5	4	3	2	1	0
DMA_BUFFER_SIZE	DMA_CHANNEL_NBR			EPT_NBR_MAX			

r 0 1 1 0 0 1 1 1

- **EPT\_NBR\_MAX: Maximal Number of Pipes/Endpoints**

This field indicates the number of hardware-implemented pipes/endpoints:

EPT_NBR_MAX				Maximal Number of Pipes/Endpoints
0	0	0	0	16
0	0	0	1	1
0	0	1	0	2
				...
1	1	1	1	15

- **DMA\_CHANNEL\_NBR: Number of DMA Channels**

This field indicates the number of hardware-implemented DMA channels:

DMA_CHANNEL_NBR			Number of DMA Channels
0	0	0	Reserved
0	0	1	1
0	1	0	2
			...
1	1	1	7

- **DMA\_BUFFER\_SIZE: DMA Buffer Size**

This field indicates the size of the DMA buffer:

DMA_BUFFER_SIZE	DMA Buffer Size
0	16 bits
1	24 bits

- **DMA\_FIFO\_WORD\_DEPTH: DMA FIFO Depth in Words**

This field indicates the DMA FIFO depth controller in words:

DMA_FIFO_WORD_DEPTH				DMA FIFO Depth in Words
0	0	0	0	16
0	0	0	1	1
0	0	1	0	2
				...
1	1	1	1	15

- **FIFO\_MAX\_SIZE: Maximal FIFO Size**

This field indicates the maximal FIFO size, i.e. the DPRAM size:

FIFO_MAX_SIZE			Maximal FIFO Size
0	0	0	< 256 bytes
0	0	1	< 512 bytes
0	1	0	< 1024 bytes
0	1	1	< 2048 bytes
1	0	0	< 4096 bytes
1	0	1	< 8192 bytes
1	1	0	< 16384 bytes
1	1	1	>= 16384 bytes

- **BYTE\_WRITE\_DPRAM: DPRAM Byte-Write Capability**

This field indicates whether the DPRAM is byte-write capable:

BYTE_WRITE_DPRAM	DPRAM Byte-Write Capability
0	DPRAM byte write lanes have shadow logic implemented in the USB macro IP interface.
1	DPRAM is natively byte-write capable.

## 30.8.1.7 USB IP PB Address Size Register (UADDRSIZE)

**Offset:** 0x0820  
**Register Name:** UADDRSIZE  
**Access Type:** Read-Only  
**Read Value:** 0x00001000

31	30	29	28	27	26	25	24
UADDRSIZE							
r							
0	0	0	0	0	0	0	0
23	22	21	20	19	18	17	16
UADDRSIZE							
r							
0	0	0	0	0	0	0	0
15	14	13	12	11	10	9	8
UADDRSIZE							
r							
0	0	0	1	0	0	0	0
7	6	5	4	3	2	1	0
UADDRSIZE							
r							
0	0	0	0	0	0	0	0

- **UADDRSIZE: IP PB Address Size**

This field indicates the size of the PB address space reserved for the USB macro IP interface (2 at the power of the number of bits reserved to encode the PB addresses of the USB macro IP interface relatively to its base address).

## 30.8.1.8 USB IP Name Register 1 (UNAME1)

**Offset:** 0x0824  
**Register Name:** UNAME1  
**Access Type:** Read-Only  
**Read Value:** 0x48555342 ("HUSB")

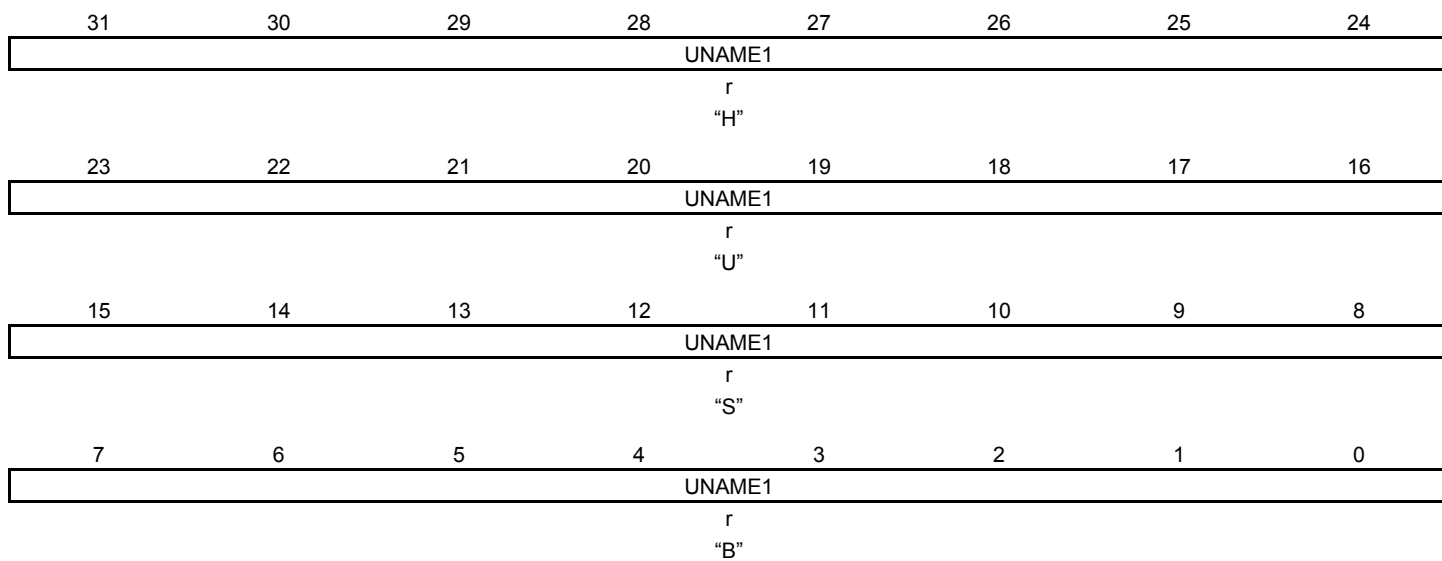

- **UNAME1: IP Name Part 1**

This field indicates the 1<sup>st</sup> part of the ASCII-encoded name of the USB macro IP.

## 30.8.1.9 USB IP Name Register 2 (UNAME2)

**Offset:** 0x0828  
**Register Name:** UNAME2  
**Access Type:** Read-Only  
**Read Value:** 0x004F5447 (“\0OTG”)

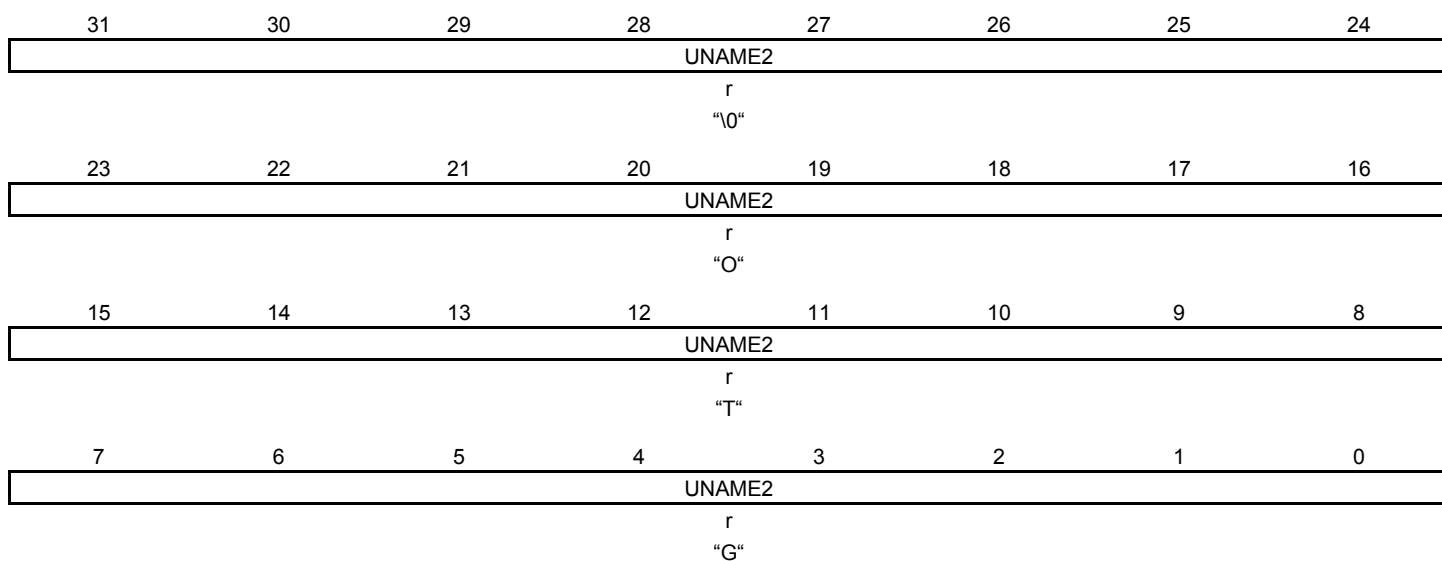

- **UNAME2: IP Name Part 2**

This field indicates the 2<sup>nd</sup> part of the ASCII-encoded name of the USB macro IP.



## 30.8.1.10 USB Finite State Machine Status Register (USBFSM)

**Offset:** 0x082C  
**Register Name:** USBFSM  
**Access Type:** Read-Only  
**Read Value:** 0x00000009

31	30	29	28	27	26	25	24
-	-	-	-	-	-	-	-
0	0	0	0	0	0	0	0
23	22	21	20	19	18	17	16
-	-	-	-	-	-	-	-
0	0	0	0	0	0	0	0
15	14	13	12	11	10	9	8
-	-	-	-	-	-	-	-
0	0	0	0	0	0	0	0
7	6	5	4	3	2	1	0
-	-	-	-	DRDSTATE			
0	0	0	0	1	0	0	1

### • DRDSTATE

This field indicates the state of the USB controller.

Refer to the OTG specification for more details.

USBFSM	Description
0	a_idle state : this is the start state for A-devices (when the ID pin is 0)
1	a_wait_vrise : In this state, the A-device waits for the voltage on VBus to rise above the A-device VBus Valid threshold (4.4 V).
2	a_wait_bcon : In this state, the A-device waits for the B-device to signal a connection.
3	a_host : In this state, the A-device that operates in Host mode is operational.
4	a_suspend : The A-device operating as a host is in the suspend mode.
5	a_peripheral : The A-device operates as a peripheral.
6	a_wait_vfall : In this state, the A-device waits for the voltage on VBus to drop below the A-device Session Valid threshold (1.4 V).
7	a_vbus_err : In this state, the A-device waits for recovery of the overcurrent condition that caused it to enter this state.
8	a_wait_discharge : In this state, the A-device waits for the data usb line to discharge (100 us).
9	b_idle : this is the start state for B-device (when the ID pin is 1).
10	b_peripheral : In this state, the B-device acts as the peripheral.

USBFSM	Description
11	b_wait_begin_hnp : In this state, the B-device is in suspend mode and waits until 3 ms before initiating the HNP protocol if requested.
12	b_wait_discharge : In this state, the B-device waits for the data usb line to discharge (100 us) before becoming Host.
13	b_wait_acon : In this state, the B-device waits for the A-device to signal a connect before becoming B-Host.
14	b_host : In this state, the B-device acts as the Host.
15	b_srp_init : In this state, the B-device attempts to start a session using the SRP protocol.

## 30.8.2 USB Device Registers

### 30.8.2.1 USB Device General Control Register (UDCON)

**Offset:** 0x0000  
**Register Name:** UDCON  
**Access Type:** Read/Write  
**Reset Value:** 0x00000100

31	30	29	28	27	26	25	24	
-	-	-	-	-	-	-	-	
23	22	21	20	19	18	17	16	
-	-	-	-	-	-	-	-	
15	14	13	12	11	10	9	8	
-	-	-	LS	-	-	RMWKUP	DETACH	
			rw			rwu	rw	
			0			0	1	
7	6	5	4	3	2	1	0	
ADDEN	UADD							
rwu				rwu				
0	0	0	0	0	0	0	0	

- **UADD: USB Address**

Set to configure the device address.

Cleared by hardware upon receiving a USB reset.

- **ADDEN: Address Enable**

Set to activate the UADD field (USB address).

Cleared by hardware upon receiving a USB reset.

Clearing by software has no effect.

- **DETACH: Detach**

Set to physically detach the device (disconnect internal pull-up resistor from D+ and D-).

Clear to reconnect the device.

- **RMWKUP: Remote Wake-Up**

Set to send an upstream resume to the host for a remote wake-up.

Cleared by hardware upon receiving a USB reset or once the upstream resume has been sent.

Clearing by software has no effect.

- **LS: Low-Speed Mode Force**

Set to force the low-speed mode.

Clear to unforce the low-speed mode. Then, the full-speed mode is active.

Note that this bit can be set/cleared even if USBE = 0 or FRZCLK = 1. Disabling the USB controller (by clearing the USBE bit) does not reset this bit.

## 30.8.2.2 USB Device Global Interrupt Register (UDINT)

**Offset:** 0x0004  
**Register Name:** UDINT  
**Access Type:** Read-Only  
**Reset Value:** 0x00000000

31	30	29	28	27	26	25	24
	DMA6INT	DMA5INT	DMA4INT	DMA3INT	DMA2INT	DMA1INT	–
	ru	ru	ru	ru	ru	ru	
	0	0	0	0	0	0	
23	22	21	20	19	18	17	16
–	–	–			EP6INT	EP5INT	EP4INT
					ru	ru	ru
					0	0	0
15	14	13	12	11	10	9	8
EP3INT	EP2INT	EP1INT	EP0INT	–	–	–	–
ru	ru	ru	ru				
0	0	0	0				
7	6	5	4	3	2	1	0
–	UPRSM	EORSM	WAKEUP	EORST	SOF	–	SUSP
	ru	ru	ru	ru	ru		ru
	0	0	0	0	0		0

- **SUSP: Suspend Interrupt Flag**

Set by hardware when a USB “Suspend” idle bus state has been detected for 3 frame periods (J state for 3 ms). This triggers a USB interrupt if SUSPE = 1.

Shall be cleared by software (by setting the SUSPC bit) to acknowledge the interrupt.

Cleared by hardware when a Wake-Up interrupt (WAKEUP) is raised.

- **SOF: Start of Frame Interrupt Flag**

Set by hardware when a USB “Start of Frame” PID (SOF) has been detected (every 1 ms). This triggers a USB interrupt if SOFE = 1. The FNUM field is updated.

Shall be cleared by software (by setting the SOFC bit) to acknowledge the interrupt.

- **EORST: End of Reset Interrupt Flag**

Set by hardware when a USB “End of Reset” has been detected. This triggers a USB interrupt if EORSTE = 1.

Shall be cleared by software (by setting the EORSTC bit) to acknowledge the interrupt.

- **WAKEUP: Wake-Up Interrupt Flag**

Asynchronous interrupt.

Set by hardware when the USB controller is reactivated by a filtered non-idle signal from the lines (not by an upstream resume). This triggers an interrupt if WAKEUPE = 1.

Shall be cleared by software (by setting the WAKEUPC bit) to acknowledge the interrupt (USB clock inputs must be enabled before).

Cleared by hardware when a Suspend interrupt (SUSP) is raised.

Note that this interrupt is generated even if the clock is frozen by the FRZCLK bit.

- **EORSM: End of Resume Interrupt Flag**

Set by hardware when the USB controller detects a valid “End of Resume” signal initiated by the host. This triggers a USB interrupt if EORSME = 1.

Shall be cleared by software (by setting the EORSMC bit) to acknowledge the interrupt.

- **UPRSM: Upstream Resume Interrupt Flag**

Set by hardware when the USB controller sends a resume signal called “Upstream Resume”. This triggers a USB interrupt if UPRSME = 1.

Shall be cleared by software (by setting the UPRSMC bit) to acknowledge the interrupt (USB clock inputs must be enabled before).

- **EPXINT, X in [0..6]: Endpoint X Interrupt Flag**

Set by hardware when an interrupt is triggered by the endpoint X (UESTAX, UECONX). This triggers a USB interrupt if EPXINTE = 1.

Cleared by hardware when the interrupt source is serviced.

- **DMAXINT, X in [1..6]: DMA Channel X Interrupt Flag**

Set by hardware when an interrupt is triggered by the DMA channel X. This triggers a USB interrupt if DMAXINTE = 1.

Cleared by hardware when the UDDMAX\_STATUS interrupt source is cleared.

## 30.8.2.3 USB Device Global Interrupt Clear Register (UDINTCLR)

**Offset:** 0x0008  
**Register Name:** UDINTCLR  
**Access Type:** Write-Only  
**Read Value:** 0x00000000

31	30	29	28	27	26	25	24
–	–	–	–	–	–	–	–
23	22	21	20	19	18	17	16
–	–	–	–	–	–	–	–
15	14	13	12	11	10	9	8
–	–	–	–	–	–	–	–
7	6	5	4	3	2	1	0
–	UPRSMC	EORSMC	WAKEUPC	EORSTC	SOFC	–	SUSPC
	w	w	w	w	w		w
	0	0	0	0	0		0

- **SUSPC: Suspend Interrupt Flag Clear**

Set to clear SUSP.

Clearing has no effect.

Always read as 0.

- **SOFC: Start of Frame Interrupt Flag Clear**

Set to clear SOF.

Clearing has no effect.

Always read as 0.

- **EORSTC: End of Reset Interrupt Flag Clear**

Set to clear EORST.

Clearing has no effect.

Always read as 0.

- **WAKEUPC: Wake-Up Interrupt Flag Clear**

Set to clear WAKEUP.

Clearing has no effect.

Always read as 0.

- **EORSMC: End of Resume Interrupt Flag Clear**

Set to clear EORSM.

Clearing has no effect.

Always read as 0.

- **UPRSMC: Upstream Resume Interrupt Flag Clear**

Set to clear UPRSM.

Clearing has no effect.

Always read as 0.



## 30.8.2.4 USB Device Global Interrupt Set Register (UDINTSET)

**Offset:** 0x000C  
**Register Name:** UDINTSET  
**Access Type:** Write-Only  
**Read Value:** 0x00000000

31	30	29	28	27	26	25	24
	DMA7INTS	DMA5INTS	DMA4INTS	DMA3INTS	DMA2INTS	DMA1INTS	–
	w	w	w	w	w	w	
	0	0	0	0	0	0	
23	22	21	20	19	18	17	16
–	–	–	–	–	–	–	–
15	14	13	12	11	10	9	8
–	–	–	–	–	–	–	–
7	6	5	4	3	2	1	0
–	UPRSMS	EORSMS	WAKEUPS	EORSTS	SOFS	–	SUSPS
	w	w	w	w	w		w
	0	0	0	0	0		0

- **SUSPS: Suspend Interrupt Flag Set**

Set to set SUSP, what may be useful for test or debug purposes.

Clearing has no effect.

Always read as 0.

- **SOFS: Start of Frame Interrupt Flag Set**

Set to set SOF, what may be useful for test or debug purposes.

Clearing has no effect.

Always read as 0.

- **EORSTS: End of Reset Interrupt Flag Set**

Set to set EORST, what may be useful for test or debug purposes.

Clearing has no effect.

Always read as 0.

- **WAKEUPS: Wake-Up Interrupt Flag Set**

Set to set WAKEUP, what may be useful for test or debug purposes.

Clearing has no effect.

Always read as 0.

- **EORSMS: End of Resume Interrupt Flag Set**

Set to set EORSM, what may be useful for test or debug purposes.

Clearing has no effect.

Always read as 0.

- **UPRSMS: Upstream Resume Interrupt Flag Set**

Set to set UPRSM, what may be useful for test or debug purposes.

Clearing has no effect.

Always read as 0.

- **DMAXINTS, X in [1..6]: DMA Channel X Interrupt Flag Set**

Set to set DMAXINT, what may be useful for test or debug purposes.

Clearing has no effect.

Always read as 0.

## 30.8.2.5 USB Device Global Interrupt Enable Register (UDINTE)

**Offset:** 0x0010  
**Register Name:** UDINTE  
**Access Type:** Read-Only  
**Reset Value:** 0x00000000

31	30	29	28	27	26	25	24
	DMA6INTE	DMA5INTE	DMA4INTE	DMA3INTE	DMA2INTE	DMA1INTE	–
	r	r	r	r	r	r	
	0	0	0	0	0	0	
23	22	21	20	19	18	17	16
–	–	–			EP6INTE	EP5INTE	EP4INTE
					r	r	r
					0	0	0
15	14	13	12	11	10	9	8
EP3INTE	EP2INTE	EP1INTE	EP0INTE	–	–	–	–
r	r	r	r				
0	0	0	0				
7	6	5	4	3	2	1	0
–	UPRSME	EORSME	WAKEUPE	EORSTE	SOFE	–	SUSPE
	r	r	r	r	r		r
	0	0	0	0	0		0

- **SUSPE: Suspend Interrupt Enable**

Set by software (by setting the SUSPES bit) to enable the Suspend interrupt (SUSP).

Clear by software (by setting the SUSPEC bit) to disable the Suspend interrupt (SUSP).

- **SOFE: Start of Frame Interrupt Enable**

Set by software (by setting the SOFES bit) to enable the Start of Frame interrupt (SOF).

Clear by software (by setting the SOFEC bit) to disable the Start of Frame interrupt (SOF).

- **EORSTE: End of Reset Interrupt Enable**

Set by software (by setting the EORSTES bit) to enable the End of Reset interrupt (EORST).

Clear by software (by setting the EORSTEC bit) to disable the End of Reset interrupt (EORST).

- **WAKEUPE: Wake-Up Interrupt Enable**

Set by software (by setting the WAKEUPES bit) to enable the Wake-Up interrupt (WAKEUP).

Clear by software (by setting the WAKEUPEC bit) to disable the Wake-Up interrupt (WAKEUP).

- **EORSME: End of Resume Interrupt Enable**

Set by software (by setting the EORSMES bit) to enable the End of Resume interrupt (EORSM).

Clear by software (by setting the EORSMEC bit) to disable the End of Resume interrupt (EORSM).

- **UPRSME: Upstream Resume Interrupt Enable**

Set by software (by setting the UPRSMES bit) to enable the Upstream Resume interrupt (UPRSM).

Clear by software (by setting the UPRSMEC bit) to disable the Upstream Resume interrupt (UPRSM).

- **EPXINTE, X in [0..6]: Endpoint X Interrupt Enable**

Set by software (by setting the EPXINTES bit) to enable the Endpoint X interrupt (EPXINT).

Clear by software (by setting the EPXINTEC bit) to disable the Endpoint X interrupt (EPXINT).

- **DMAXINTE, X in [1..6]: DMA Channel X Interrupt Enable**

Set by software (by setting the DMAXINTES bit) to enable the DMA Channel X interrupt (DMAXINT).

Clear by software (by setting the DMAXINTEC bit) to disable the DMA Channel X interrupt (DMAXINT).

## 30.8.2.6 USB Device Global Interrupt Enable Clear Register (UDINTECLR)

**Offset:** 0x0014  
**Register Name:** UDINTECLR  
**Access Type:** Write-Only  
**Read Value:** 0x00000000

31	30	29	28	27	26	25	24
–	DMA6INTEC	DMA5INTEC	DMA4INTEC	DMA3INTEC	DMA2INTEC	DMA1INTEC	–
	w	w	w	w	w	w	
	0	0	0	0	0	0	
23	22	21	20	19	18	17	16
–	–	–	–	–	EP6INTEC	EP5INTEC	EP4INTEC
					w	w	w
					0	0	0
15	14	13	12	11	10	9	8
EP3INTEC	EP2INTEC	EP1INTEC	EP0INTEC	–	–	–	–
w	w	w	w				
0	0	0	0				
7	6	5	4	3	2	1	0
–	UPRSMEC	EORSMEC	WAKEUPEC	EORSTEC	SOFEC	–	SUSPEC
	w	w	w	w	w		w
	0	0	0	0	0		0

- **SUSPEC: Suspend Interrupt Enable Clear**

Set to clear SUSPE.

Clearing has no effect.

Always read as 0.

- **SOFEC: Start of Frame Interrupt Enable Clear**

Set to clear SOFE.

Clearing has no effect.

Always read as 0.

- **EORSTEC: End of Reset Interrupt Enable Clear**

Set to clear EORSTE.

Clearing has no effect.

Always read as 0.

- **WAKEUPEC: Wake-Up Interrupt Enable Clear**

Set to clear WAKEUPE.

Clearing has no effect.

Always read as 0.

- **EORSMEC: End of Resume Interrupt Enable Clear**

Set to clear EORSME.

Clearing has no effect.

Always read as 0.

- **UPRSMEC: Upstream Resume Interrupt Enable Clear**

Set to clear UPRSME.

Clearing has no effect.

Always read as 0.

- **EPXINTEC, X in [0..6]: Endpoint X Interrupt Enable Clear**

Set to clear EPXINTE.

Clearing has no effect.

Always read as 0.

- **DMAXINTEC, X in [1..6]: DMA Channel X Interrupt Enable Clear**

Set to clear DMAXINTE.

Clearing has no effect.

Always read as 0.

## 30.8.2.7 USB Device Global Interrupt Enable Set Register (UDINTESET)

**Offset:** 0x0018  
**Register Name:** UDINTESET  
**Access Type:** Write-Only  
**Read Value:** 0x00000000

31	30	29	28	27	26	25	24
–	DMA6INTES	DMA5INTES	DMA4INTES	DMA3INTES	DMA2INTES	DMA1INTES	–
	w	w	w	w	w	w	
	0	0	0	0	0	0	
23	22	21	20	19	18	17	16
–	–	–	–	–	EP6INTES	EP5INTES	EP4INTES
					w	w	w
					0	0	0
15	14	13	12	11	10	9	8
EP3INTES	EP2INTES	EP1INTES	EP0INTES	–	–	–	–
w	w	w	w				
0	0	0	0				
7	6	5	4	3	2	1	0
–	UPRSMES	EORSMES	WAKEUPES	EORSTES	SOFES	–	SUSPES
	w	w	w	w	w		w
	0	0	0	0	0		0

- **SUSPES: Suspend Interrupt Enable Set**

Set to set SUSPE.

Clearing has no effect.

Always read as 0.

- **SOFES: Start of Frame Interrupt Enable Set**

Set to set SOFE.

Clearing has no effect.

Always read as 0.

- **EORSTES: End of Reset Interrupt Enable Set**

Set to set EORSTE.

Clearing has no effect.

Always read as 0.

- **WAKEUPES: Wake-Up Interrupt Enable Set**

Set to set WAKEUPE.

Clearing has no effect.

Always read as 0.

- **EORSMES: End of Resume Interrupt Enable Set**

Set to set EORSME.

Clearing has no effect.

Always read as 0.

- **UPRSMES: Upstream Resume Interrupt Enable Set**

Set to set UPRSME.

Clearing has no effect.

Always read as 0.

- **EPXINTES, X in [0..6]: Endpoint X Interrupt Enable Set**

Set to set EPXINTE.

Clearing has no effect.

Always read as 0.

- **DMAXINTES, X in [1..6]: DMA Channel X Interrupt Enable Set**

Set to set DMAXINTE.

Clearing has no effect.

Always read as 0.





## 30.8.2.9 USB Endpoint Enable/Reset Register (UERST)

**Offset:** 0x001C  
**Register Name:** UERST  
**Access Type:** Read/Write  
**Reset Value:** 0x00000000

31	30	29	28	27	26	25	24
–	–	–	–	–	–	–	–

23	22	21	20	19	18	17	16
–	EPRST6	EPRST5	EPRST4	EPRST3	EPRST2	EPRST1	EPRST0
	rwu	rwu	rwu	rwu	rwu	rwu	rwu
	0	0	0	0	0	0	0
15	14	13	12	11	10	9	8
–	–	–	–	–	–	–	–

7	6	5	4	3	2	1	0
–	EPEN6	EPEN5	EPEN4	EPEN3	EPEN2	EPEN1	EPEN0
	rw	rw	rw	rw	rw	rw	rw
	0	0	0	0	0	0	0

- **EPENX, X in [0..6]: Endpoint X Enable**

Set to enable the endpoint X.

Clear to disable the endpoint X, what forces the endpoint X state to inactive (no answer to USB requests) and resets the endpoint X registers (UECFGX, UESTAX, UECONX) but not the endpoint configuration (ALLOC, EPBK, EPSIZE, EPDIR, EPTYPE).

- **EPRSTX, X in [0..6]: Endpoint X Reset**

Set by software to reset the endpoint X FIFO prior to any other operation, upon hardware reset or when a USB bus reset has been received. This resets the endpoint X registers (UECFGX, UESTAX, UECONX) but not the endpoint configuration (ALLOC, EPBK, EPSIZE, EPDIR, EPTYPE).

All the endpoint mechanism (FIFO counter, reception, transmission, etc.) is reset apart from the Data Toggle Sequence field (DTSEQ) which can be cleared by setting the RSTDT bit (by setting the RSTDTS bit).

The endpoint configuration remains active and the endpoint is still enabled.

Then, clear by software to complete the reset operation and to start using the FIFO.

Cleared by hardware upon receiving a USB reset.

## 30.8.2.10 USB Endpoint X Configuration Register (UECFGX)

**Offset:** 0x0100 + X . 0x04  
**Register Name:** UECFGX, X in [0..6]  
**Access Type:** Read/Write  
**Reset Value:** 0x00000000

31	30	29	28	27	26	25	24
–	–	–	–	–	–	–	–
23	22	21	20	19	18	17	16
–	–	–	–	–	–	–	–
15	14	13	12	11	10	9	8
–	–	–	EPTYPE		–	AUTOSW	EPDIR
			rwu			rwu	
			0	0		0	0
7	6	5	4	3	2	1	0
–	EPSIZE			EPBK		ALLOC	–
		rwu		rwu		rwu	
	0	0	0	0	0	0	0

- **ALLOC: Endpoint Memory Allocate**

Set to allocate the endpoint memory.

Clear to free the endpoint memory.

Cleared by hardware upon receiving a USB reset (except for the endpoint 0).

Note that after setting this bit, the user should check the CFGOK bit to know whether the allocation of this endpoint is correct.

- **EPBK: Endpoint Banks**

Set to select the number of banks for the endpoint:

EPBK		Endpoint Banks
0	0	1 (single-bank endpoint)
0	1	2 (double-bank endpoint)
1	0	3 (triple-bank endpoint)
1	1	Reserved

For control endpoints, a single-bank endpoint (00b) should be selected.

Cleared by hardware upon receiving a USB reset (except for the endpoint 0).

- **EPSIZE: Endpoint Size**

Set to select the size of each endpoint bank:

EPSIZE			Endpoint Size
0	0	0	8 bytes
0	0	1	16 bytes
0	1	0	32 bytes
0	1	1	64 bytes
1	0	0	128 bytes
1	0	1	256 bytes
1	1	0	512 bytes
1	1	1	1024 bytes

Cleared by hardware upon receiving a USB reset (except for the endpoint 0).

- **EPDIR: Endpoint Direction**

Set to select the endpoint direction:

EPDIR	Endpoint Direction
0	OUT
1	IN (not for control endpoints)

Cleared by hardware upon receiving a USB reset.

- **AUTOSW: Automatic Switch**

Set to automatically switch bank when it is ready.

Clear to disable the automatic bank switching.

Cleared by hardware upon receiving a USB reset.

- **EPTYPE: Endpoint Type**

Set to select the endpoint type:

EPTYPE		Endpoint Type
0	0	Control
0	1	Isochronous
1	0	Bulk
1	1	Interrupt

Cleared by hardware upon receiving a USB reset.

## 30.8.2.11 USB Endpoint X Status Register (UESTAX)

**Offset:** 0x0130 + X . 0x04  
**Register Name:** UESTAX, X in [0..6]  
**Access Type:** Read-Only  
**Reset Value:** 0x00000100

31	30	29	28	27	26	25	24
-		BYCT					
		ru					
	0	0	0	0	0	0	0
23	22	21	20	19	18	17	16
BYCT			-		CFGOK	CTRLDIR	RWALL
ru					ru	ru	ru
0	0	0	0		0	0	0
15	14	13	12	11	10	9	8
CURRBK		NBUSYBK		-		DTSEQ	
ru		ru				ru	
0	0	0	0			0	1
7	6	5	4	3	2	1	0
SHORT PACKET	STALLED/ CRCERRI	OVERFI	NAKINI	NAKOUTI	RXSTPI/ UNDERFI	RXOUTI	TXINI
ru	ru	ru	ru	ru	ru	ru	ru
0	0	0	0	0	0	0	0

### • TXINI: Transmitted IN Data Interrupt Flag

For control endpoints:

Set by hardware when the current bank is ready to accept a new IN packet. This triggers an EPXINT interrupt if TXINE = 1.

Shall be cleared by software (by setting the TXINIC bit) to acknowledge the interrupt and to send the packet.

For isochronous, bulk and interrupt IN endpoints:

Set by hardware at the same time as FIFOCON when the current bank is free. This triggers an EPXINT interrupt if TXINE = 1.

Shall be cleared by software (by setting the TXINIC bit) to acknowledge the interrupt, what has no effect on the endpoint FIFO.

The software then writes into the FIFO and clears the FIFOCON bit to allow the USB controller to send the data. If the IN endpoint is composed of multiple banks, this also switches to the next bank. The TXINI and FIFOCON bits are updated by hardware in accordance with the status of the next bank.

TXINI shall always be cleared before clearing FIFOCON.

This bit is inactive (cleared) for isochronous, bulk and interrupt OUT endpoints.

### • RXOUTI: Received OUT Data Interrupt Flag

For control endpoints:

Set by hardware when the current bank contains a bulk OUT packet (data or status stage). This triggers an EPXINT interrupt if RXOUTE = 1.

Shall be cleared by software (by setting the RXOUTIC bit) to acknowledge the interrupt and to free the bank.

For isochronous, bulk and interrupt OUT endpoints:

Set by hardware at the same time as FIFOCON when the current bank is full. This triggers an EPXINT interrupt if RXOUTE = 1.

Shall be cleared by software (by setting the RXOUTIC bit) to acknowledge the interrupt, what has no effect on the endpoint FIFO.

The software then reads from the FIFO and clears the FIFOCON bit to free the bank. If the OUT endpoint is composed of multiple banks, this also switches to the next bank. The RXOUTI and FIFOCON bits are updated by hardware in accordance with the status of the next bank.

RXOUTI shall always be cleared before clearing FIFOCON.

This bit is inactive (cleared) for isochronous, bulk and interrupt IN endpoints.

- **RXSTPI: Received SETUP Interrupt Flag**

For control endpoints, set by hardware to signal that the current bank contains a new valid SETUP packet. This triggers an EPXINT interrupt if RXSTPE = 1.

Shall be cleared by software (by setting the RXSTPIC bit) to acknowledge the interrupt and to free the bank.

This bit is inactive (cleared) for bulk and interrupt IN/OUT endpoints and it means UNDERFI for isochronous IN/OUT endpoints.

- **UNDERFI: Underflow Interrupt Flag**

For isochronous IN/OUT endpoints, set by hardware when an underflow error occurs. This triggers an EPXINT interrupt if UNDERFE = 1.

An underflow can occur during IN stage if the host attempts to read from an empty bank. A zero-length packet is then automatically sent by the USB controller.

An underflow can also occur during OUT stage if the host sends a packet while the bank is already full. Typically, the CPU is not fast enough. The packet is lost.

Shall be cleared by software (by setting the UNDERFIC bit) to acknowledge the interrupt.

This bit is inactive (cleared) for bulk and interrupt IN/OUT endpoints and it means RXSTPI for control endpoints.

- **NAKOUTI: NAKed OUT Interrupt Flag**

Set by hardware when a NAK handshake has been sent in response to an OUT request from the host. This triggers an EPXINT interrupt if NAKOUTE = 1.

Shall be cleared by software (by setting the NAKOUTIC bit) to acknowledge the interrupt.

- **NAKINI: NAKed IN Interrupt Flag**

Set by hardware when a NAK handshake has been sent in response to an IN request from the host. This triggers an EPXINT interrupt if NAKINE = 1.

Shall be cleared by software (by setting the NAKINIC bit) to acknowledge the interrupt.

- **OVERFI: Overflow Interrupt Flag**

Set by hardware when an overflow error occurs. This triggers an EPXINT interrupt if OVERFE = 1.

For all endpoint types, an overflow can occur during OUT stage if the host attempts to write into a bank that is too small for the packet. The packet is acknowledged and the Received OUT Data interrupt (RXOUTI) is raised as if no overflow had occurred. The bank is filled with all the first bytes of the packet that fit in.

Shall be cleared by software (by setting the OVERFIC bit) to acknowledge the interrupt.

- **STALLEDI: STALLed Interrupt Flag**

Set by hardware to signal that a STALL handshake has been sent. To do that, the software has to set the STALLRQ bit (by setting the STALLRQS bit). This triggers an EPXINT interrupt if STALLEDE = 1.

Shall be cleared by software (by setting the STALLEDIC bit) to acknowledge the interrupt.

- **CRCERRI: CRC Error Interrupt Flag**

Set by hardware to signal that a CRC error has been detected in an isochronous OUT endpoint. The OUT packet is stored in the bank as if no CRC error had occurred. This triggers an EPXINT interrupt if CRCERRE = 1.

Shall be cleared by software (by setting the CRCERRIC bit) to acknowledge the interrupt.

- **SHORTPACKET: Short Packet Interrupt Flag**

For non-control OUT endpoints, set by hardware when a short packet has been received.

For non-control IN endpoints, set by hardware when a short packet is transmitted upon ending a DMA transfer, thus signaling an end of isochronous frame or a bulk or interrupt end of transfer, this only if the End of DMA Buffer Output Enable bit (DMAEND\_EN) and the Automatic Switch bit (AUTOSW) are set.

This triggers an EPXINT interrupt if SHORTPACKETE = 1.

Shall be cleared by software (by setting the SHORTPACKETC bit) to acknowledge the interrupt.

- **DTSEQ: Data Toggle Sequence**

Set by hardware to indicate the PID of the current bank:

DTSEQ		Data Toggle Sequence
0	0	Data0
0	1	Data1
1	X	Reserved

For IN transfers, it indicates the data toggle sequence that will be used for the next packet to be sent. This is not relative to the current bank.

For OUT transfers, this value indicates the last data toggle sequence received on the current bank.

Note that by default DTSEQ = 01b, as if the last data toggle sequence was Data1, so the next sent or expected data toggle sequence should be Data0.

- **NBUSYBK: Number of Busy Banks**

Set by hardware to indicate the number of busy banks:

NBUSYBK		Number of Busy Banks
0	0	0 (all banks free)
0	1	1
1	0	2
1	1	3

For IN endpoints, it indicates the number of banks filled by the user and ready for IN transfer. When all banks are free, this triggers an EPXINT interrupt if NBUSYBKE = 1.

For OUT endpoints, it indicates the number of banks filled by OUT transactions from the host. When all banks are busy, this triggers an EPXINT interrupt if NBUSYBKE = 1.

Note that when the FIFOCON bit is cleared (by setting the FIFOCONC bit) to validate a new bank, this field is updated 2 or 3 clock cycles later to calculate the address of the next bank.

An EPXINT interrupt is triggered if :

- for IN endpoint, NBUSYBKE=1 and all the banks are free.
- for OUT endpoint, NBUSYBKE=1 and all the banks are busy.

• **CURRBK: Current Bank**

For non-control endpoints, set by hardware to indicate the current bank:

CURRBK		Current Bank
0	0	Bank0
0	1	Bank1
1	0	Bank2
1	1	Reserved

Note that this field may be updated 1 clock cycle after the RWALL bit changes, so the user should not poll this field as an interrupt flag.

• **RWALL: Read/Write Allowed**

For IN endpoints, set by hardware when the current bank is not full, i.e. the software can write further data into the FIFO.

For OUT endpoints, set by hardware when the current bank is not empty, i.e. the software can read further data from the FIFO.

Never set if STALLRQ = 1 or in case of error.

Cleared by hardware otherwise.

This bit shall not be used for control endpoints.

• **CTRLDIR: Control Direction**

Set by hardware after a SETUP packet to indicate the direction of the following packet:

CTRLDIR	Control Direction
0	OUT
1	IN

Can not be set or cleared by software.

• **CFGOK: Configuration OK Status**

This bit is updated when the ALLOC bit is set.

Set by hardware if the endpoint X number of banks (EPBK) and size (EPSIZE) are correct compared to the maximal allowed number of banks and size for this endpoint and to the maximal FIFO size (i.e. the DPRAM size).

If this bit is cleared by hardware, the user should reprogram the UECFGX register with correct EPBK and EPSIZE values.

• **BYCT: Byte Count**

Set by the hardware to indicate the byte count of the FIFO.



For IN endpoints, incremented after each byte written by the software into the endpoint and decremented after each byte sent to the host.

For OUT endpoints, incremented after each byte received from the host and decremented after each byte read by the software from the endpoint.

Note that this field may be updated 1 clock cycle after the RWALL bit changes, so the user should not poll this field as an interrupt flag.

## 30.8.2.12 USB Endpoint X Status Clear Register (UESTAXCLR)

**Offset:** 0x0160 + X . 0x04  
**Register Name:** UESTAXCLR, X in [0..6]  
**Access Type:** Write-Only  
**Read Value:** 0x00000000

31	30	29	28	27	26	25	24
–	–	–	–	–	–	–	–

23	22	21	20	19	18	17	16
–	–	–	–	–	–	–	–

15	14	13	12	11	10	9	8
–	–	–	–	–	–	–	–

7	6	5	4	3	2	1	0
SHORT PACKETC	STALLEDIC/ CRCERRIC	OVERFIC	NAKINIC	NAKOUTIC	RXSTPIC/ UNDERFIC	RXOUTIC	TXINIC
w	w	w	w	w	w	w	w
0	0	0	0	0	0	0	0

- **TXINIC: Transmitted IN Data Interrupt Flag Clear**

Set to clear TXINI.

Clearing has no effect.

Always read as 0.

- **RXOUTIC: Received OUT Data Interrupt Flag Clear**

Set to clear RXOUTI.

Clearing has no effect.

Always read as 0.

- **RXSTPIC: Received SETUP Interrupt Flag Clear**

Set to clear RXSTPI.

Clearing has no effect.

Always read as 0.

- **UNDERFIC: Underflow Interrupt Flag Clear**

Set to clear UNDERFI.

Clearing has no effect.

Always read as 0.

- **NAKOUTIC: NAKed OUT Interrupt Flag Clear**

Set to clear NAKOUTI.

Clearing has no effect.

Always read as 0.

- **NAKINIC: NAKed IN Interrupt Flag Clear**

Set to clear NAKINI.

Clearing has no effect.

Always read as 0.

- **OVERFIC: Overflow Interrupt Flag Clear**

Set to clear OVERFI.

Clearing has no effect.

Always read as 0.

- **STALLEDIC: STALLed Interrupt Flag Clear**

Set to clear STALLEDI.

Clearing has no effect.

Always read as 0.

- **CRCERRIC: CRC Error Interrupt Flag Clear**

Set to clear CRCERRI.

Clearing has no effect.

Always read as 0.

- **SHORTPACKETC: Short Packet Interrupt Flag Clear**

Set to clear SHORTPACKET.

Clearing has no effect.

Always read as 0.

## 30.8.2.13 USB Endpoint X Status Set Register (UESTAXSET)

**Offset:** 0x0190 + X . 0x04  
**Register Name:** UESTAXSET, X in [0..6]  
**Access Type:** Write-Only  
**Read Value:** 0x00000000

31	30	29	28	27	26	25	24
-	-	-	-	-	-	-	-
23	22	21	20	19	18	17	16
-	-	-	-	-	-	-	-
15	14	13	12	11	10	9	8
-	-	-	NBUSYBKS	-	-	-	-
			w				
			0				
7	6	5	4	3	2	1	0
SHORT PACKETS	STALLEDIS/ CRCERRIS	OVERFIS	NAKINIS	NAKOUTIS	RXSTPIS/ UNDERFIS	RXOUTIS	TXINIS
w	w	w	w	w	w	w	w
0	0	0	0	0	0	0	0

- **TXINIS: Transmitted IN Data Interrupt Flag Set**

Set to set TXINI, what may be useful for test or debug purposes.

Clearing has no effect.

Always read as 0.

- **RXOUTIS: Received OUT Data Interrupt Flag Set**

Set to set RXOUTI, what may be useful for test or debug purposes.

Clearing has no effect.

Always read as 0.

- **RXSTPIS: Received SETUP Interrupt Flag Set**

Set to set RXSTPI, what may be useful for test or debug purposes.

Clearing has no effect.

Always read as 0.

- **UNDERFIS: Underflow Interrupt Flag Set**

Set to set UNDERFI, what may be useful for test or debug purposes.

Clearing has no effect.

Always read as 0.

- **NAKOUTIS: NAKed OUT Interrupt Flag Set**

Set to set NAKOUTI, what may be useful for test or debug purposes.

Clearing has no effect.

Always read as 0.

- **NAKINIS: NAKed IN Interrupt Flag Set**

Set to set NAKINI, what may be useful for test or debug purposes.

Clearing has no effect.

Always read as 0.

- **OVERFIS: Overflow Interrupt Flag Set**

Set to set OVERFI, what may be useful for test or debug purposes.

Clearing has no effect.

Always read as 0.

- **STALLEDIS: STALLed Interrupt Flag Set**

Set to set STALLEDI, what may be useful for test or debug purposes.

Clearing has no effect.

Always read as 0.

- **CRCERRIS: CRC Error Interrupt Flag Set**

Set to set CRCERRI, what may be useful for test or debug purposes.

Clearing has no effect.

Always read as 0.

- **SHORTPACKETS: Short Packet Interrupt Flag Set**

Set to set SHORTPACKET, what may be useful for test or debug purposes.

Clearing has no effect.

Always read as 0.

- **NBUSYBKS: Number of Busy Banks Interrupt Flag Set**

Set to force the Number of Busy Banks interrupt flag (NBUSYBK), what may be useful for test or debug purposes.

Set again to unforce the Number of Busy Banks interrupt flag (NBUSYBK).

Clearing has no effect.

Always read as 0.

## 30.8.2.14 USB Endpoint X Control Register (UECONX)

**Offset:** 0x01C0 + X . 0x04  
**Register Name:** UECONX, X in [0..6]  
**Access Type:** Read-Only  
**Reset Value:** 0x00000000

31	30	29	28	27	26	25	24
-	-	-	-	-	-	-	-
23	22	21	20	19	18	17	16
-	-	-	-	STALLRQ	RSTDT	-	EPDISHDMA
				ru	ru		r
				0	0		0
15	14	13	12	11	10	9	8
-	FIFOCON	KILLBK	NBUSYBKE	-	-	-	-
	ru	ru	r				
	0	0	0				
7	6	5	4	3	2	1	0
SHORT PACKETE	STALLEDE/ CRCERRE	OVERFE	NAKINE	NAKOUTE	RXSTPE/ UNDERFE	RXOUTE	TXINE
r	r	r	r	r	r	r	r
0	0	0	0	0	0	0	0

- **TXINE: Transmitted IN Data Interrupt Enable**

Set by software (by setting the TXINES bit) to enable the Transmitted IN Data interrupt (TXINI).

Clear by software (by setting the TXINEC bit) to disable the Transmitted IN Data interrupt (TXINI).

- **RXOUTE: Received OUT Data Interrupt Enable**

Set by software (by setting the RXOUTES bit) to enable the Received OUT Data interrupt (RXOUT).

Clear by software (by setting the RXOUTEC bit) to disable the Received OUT Data interrupt (RXOUT).

- **RXSTPE: Received SETUP Interrupt Enable**

Set by software (by setting the RXSTPES bit) to enable the Received SETUP interrupt (RXSTPI).

Clear by software (by setting the RXSTPEC bit) to disable the Received SETUP interrupt (RXSTPI).

- **UNDERFE: Underflow Interrupt Enable**

Set by software (by setting the UNDERFES bit) to enable the Underflow interrupt (UNDERFI).

Clear by software (by setting the UNDERFEC bit) to disable the Underflow interrupt (UNDERFI).

- **NAKOUTE: NAKed OUT Interrupt Enable**

Set by software (by setting the NAKOUTES bit) to enable the NAKed OUT interrupt (NAKOUTI).

Clear by software (by setting the NAKOUTEC bit) to disable the NAKed OUT interrupt (NAKOUTI).

- **NAKINE: NAKed IN Interrupt Enable**

Set by software (by setting the NAKINES bit) to enable the NAKed IN interrupt (NAKINI).

Clear by software (by setting the NAKINEC bit) to disable the NAKed IN interrupt (NAKINI).

- **OVERFE: Overflow Interrupt Enable**

Set by software (by setting the OVERFES bit) to enable the Overflow interrupt (OVERFI).

Clear by software (by setting the OVERFEC bit) to disable the Overflow interrupt (OVERFI).

- **STALLEDE: STALLed Interrupt Enable**

Set by software (by setting the STALLEDES bit) to enable the STALLed interrupt (STALLEDI).

Clear by software (by setting the STALLEDEC bit) to disable the STALLed interrupt (STALLEDI).

- **CRCERRE: CRC Error Interrupt Enable**

Set by software (by setting the CRCERRES bit) to enable the CRC Error interrupt (CRCERRI).

Clear by software (by setting the CRCERREC bit) to disable the CRC Error interrupt (CRCERRI).

- **SHORTPACKETE: Short Packet Interrupt Enable**

Set by software (by setting the SHORTPACKETES bit) to enable the Short Packet interrupt (SHORTPACKET).

Clear by software (by setting the SHORTPACKETEC bit) to disable the Short Packet interrupt (SHORTPACKET).

- **NBUSYBKE: Number of Busy Banks Interrupt Enable**

Set by software (by setting the NBUSYBKES bit) to enable the Number of Busy Banks interrupt (NBUSYBK).

Clear by software (by setting the NBUSYBKEC bit) to disable the Number of Busy Banks interrupt (NBUSYBK).

- **KILLBK: Kill IN Bank**

Set by software (by setting the KILLBKS bit) to kill the last written bank.

Cleared by hardware when the bank is killed.

Caution: The bank is really cleared when the “kill packet” procedure is accepted by the USB macro core. This bit is automatically cleared after the end of the procedure:

- The bank is really cleared or the bank is sent (IN transfer): NBUSYBK is decremented.
- The bank is not cleared but sent (IN transfer): NBUSYBK is decremented.
- The bank is not cleared because it was empty.

The software shall wait for this bit to be cleared before trying to kill another packet.

Note that this kill request is refused if at the same time an IN token is coming and the last bank is the current one being sent on the USB line. If at least 2 banks are ready to be sent, there is no problem to kill a packet even if an IN token is coming. Indeed, in this case, the current bank is sent (IN transfer) while the last bank is killed.

- **FIFOCON: FIFO Control**

For control endpoints:

The FIFOCON and RWALL bits are irrelevant. The software shall therefore never use them on these endpoints. When read, their value is always 0.

For IN endpoints:

Set by hardware when the current bank is free, at the same time as TXINI.

Clear by software (by setting the FIFOCONC bit) to send the FIFO data and to switch to the next bank.

For OUT endpoints:

Set by hardware when the current bank is full, at the same time as RXOUTI.

Clear by software (by setting the FIFOCONC bit) to free the current bank and to switch to the next bank.

- **EPDISHDMA: Endpoint Interrupts Disable HDMA Request Enable**

Set by software (by setting the EPDISHDMAS bit) to pause the on-going DMA channel X transfer on any Endpoint X interrupt (EPXINT), whatever the state of the Endpoint X Interrupt Enable bit (EPXINTE).

The software then has to acknowledge or to disable the interrupt source (e.g. RXOUTI) or to clear the EPDISHDMA bit (by setting the EPDISHDMAC bit) in order to complete the DMA transfer.

In ping-pong mode, if the interrupt is associated to a new system-bank packet (e.g. Bank1) and the current DMA transfer is running on the previous packet (Bank0), then the previous-packet DMA transfer completes normally, but the new-packet DMA transfer will not start (not requested).

If the interrupt is not associated to a new system-bank packet (NAKINI, NAKOUTI, etc.), then the request cancellation may occur at any time and may immediately pause the current DMA transfer.

This may be used for example to identify erroneous packets, to prevent them from being transferred into a buffer, to complete a DMA transfer by software after reception of a short packet, etc.

- **RSTDT: Reset Data Toggle**

Set by software (by setting the RSTDTS bit) to clear the data toggle sequence, i.e. to set to Data0 the data toggle sequence of the next sent (IN endpoints) or received (OUT endpoints) packet.

Cleared by hardware instantaneously.

The software does not have to wait for this bit to be cleared.

- **STALLRQ: STALL Request**

Set by software (by setting the STALLRQS bit) to request to send a STALL handshake to the host.

Cleared by hardware when a new SETUP packet is received.

Can also be cleared by software by setting the STALLRQC bit.



## 30.8.2.15 USB Endpoint X Control Clear Register (UECONXCLR)

**Offset:** 0x0220 + X . 0x04  
**Register Name:** UECONXCLR, X in [0..6]  
**Access Type:** Write-Only  
**Read Value:** 0x00000000

31	30	29	28	27	26	25	24
–	–	–	–	–	–	–	–
23	22	21	20	19	18	17	16
–	–	–	–	STALLRQC	–	–	EPDISHDMAC
				w			w
				0			0
15	14	13	12	11	10	9	8
–	FIFOCONC	–	NBUSYBKEC	–	–	–	–
	w		w				
	0		0				
7	6	5	4	3	2	1	0
SHORT PACKETEC	STALLEDEC/ CRCERREC	OVERFEC	NAKINEC	NAKOUTEC	RXSTPEC/ UNDERFEC	RXOUTEC	TXINEC
w	w	w	w	w	w	w	w
0	0	0	0	0	0	0	0

- **TXINEC: Transmitted IN Data Interrupt Enable Clear**

Set to clear TXINE.

Clearing has no effect.

Always read as 0.

- **RXOUTEC: Received OUT Data Interrupt Enable Clear**

Set to clear RXOUTE.

Clearing has no effect.

Always read as 0.

- **RXSTPEC: Received SETUP Interrupt Enable Clear**

Set to clear RXSTPE.

Clearing has no effect.

Always read as 0.

- **UNDERFEC: Underflow Interrupt Enable Clear**

Set to clear UNDERFE.

Clearing has no effect.

Always read as 0.

- **NAKOUTEC: NAKed OUT Interrupt Enable Clear**

Set to clear NAKOUTE.

Clearing has no effect.

Always read as 0.

- **NAKINEC: NAKed IN Interrupt Enable Clear**

Set to clear NAKINE.

Clearing has no effect.

Always read as 0.

- **OVERFEC: Overflow Interrupt Enable Clear**

Set to clear OVERFE.

Clearing has no effect.

Always read as 0.

- **STALLEDEC: STALLED Interrupt Enable Clear**

Set to clear STALLEDE.

Clearing has no effect.

Always read as 0.

- **CRCERREC: CRC Error Interrupt Enable Clear**

Set to clear CRCERRE.

Clearing has no effect.

Always read as 0.

- **SHORTPACKETEC: Short Packet Interrupt Enable Clear**

Set to clear SHORTPACKETE.

Clearing has no effect.

Always read as 0.

- **NBUSYBKEC: Number of Busy Banks Interrupt Enable Clear**

Set to clear NBUSYBKE.

Clearing has no effect.

Always read as 0.

- **FIFOCONC: FIFO Control Clear**

Set to clear FIFOCON.

Clearing has no effect.

Always read as 0.

- **EPDISHDMAC: Endpoint Interrupts Disable HDMA Request Enable Clear**

Set to clear EPDISHDMA.

Clearing has no effect.

Always read as 0.

- **STALLRQC: STALL Request Clear**

Set to clear STALLRQ.

Clearing has no effect.

Always read as 0.

## 30.8.2.16 USB Endpoint X Control Set Register (UECONXSET)

**Offset:** 0x01F0 + X . 0x04  
**Register Name:** UECONXSET, X in [0..6]  
**Access Type:** Write-Only  
**Read Value:** 0x00000000

31	30	29	28	27	26	25	24
–	–	–	–	–	–	–	–
23	22	21	20	19	18	17	16
–	–	–	–	STALLRQS	RSTDTS	–	EPDISHDMAS
				w			w
				0			0
15	14	13	12	11	10	9	8
–	–	KILLBKS	NBUSYBKES	–	–	–	–
	w		w				
	0		0				
7	6	5	4	3	2	1	0
SHORT PACKETES	STALLEDES/ CRCERRS	OVERFES	NAKINES	NAKOUTES	RXSTPES/ UNDERFES	RXOUTES	TXINES
w	w	w	w	w	w	w	w
0	0	0	0	0	0	0	0

- **TXINES: Transmitted IN Data Interrupt Enable Set**

Set to set TXINE.

Clearing has no effect.

Always read as 0.

- **RXOUTES: Received OUT Data Interrupt Enable Set**

Set to set RXOUTE.

Clearing has no effect.

Always read as 0.

- **RXSTPES: Received SETUP Interrupt Enable Set**

Set to set RXSTPE.

Clearing has no effect.

Always read as 0.

- **UNDERFES: Underflow Interrupt Enable Set**

Set to set UNDERFE.

Clearing has no effect.

Always read as 0.

- **NAKOUTES: NAKed OUT Interrupt Enable Set**

Set to set NAKOUTE.

Clearing has no effect.

Always read as 0.

- **NAKINES: NAKed IN Interrupt Enable Set**

Set to set NAKINE.

Clearing has no effect.

Always read as 0.

- **OVERFES: Overflow Interrupt Enable Set**

Set to set OVERFE.

Clearing has no effect.

Always read as 0.

- **STALLEDES: STALLED Interrupt Enable Set**

Set to set STALLEDE.

Clearing has no effect.

Always read as 0.

- **CRCERRES: CRC Error Interrupt Enable Set**

Set to set CRCERRE.

Clearing has no effect.

Always read as 0.

- **SHORTPACKETES: Short Packet Interrupt Enable Set**

Set to set SHORTPACKETE.

Clearing has no effect.

Always read as 0.

- **NBUSYBKES: Number of Busy Banks Interrupt Enable Set**

Set to set NBUSYBKE.

Clearing has no effect.

Always read as 0.

- **KILLBKS: Kill IN Bank Set**

Set to set KILLBK.

Clearing has no effect.

Always read as 0.

- **EPDISHDMAS: Endpoint Interrupts Disable HDMA Request Enable Set**

Set to set EPDISHDMA.

Clearing has no effect.

Always read as 0.

- **RSTDTS: Reset Data Toggle Set**

Set to set RSTDTS.

Clearing has no effect.

Always read as 0.

- **STALLRQS: STALL Request Set**

Set to set STALLRQ.

Clearing has no effect.

Always read as 0.

## 30.8.2.17 USB Device DMA Channel X Next Descriptor Address Register (UDDMAX\_NEXTDESC)

**Offset:** 0x0310 + (X - 1) . 0x10  
**Register Name:** UDDMAX\_NEXTDESC, X in [1..6]  
**Access Type:** Read/Write  
**Reset Value:** 0x00000000

31	30	29	28	27	26	25	24
NXT_DESC_ADDR							
rwu							
0	0	0	0	0	0	0	0
23	22	21	20	19	18	17	16
NXT_DESC_ADDR							
rwu							
0	0	0	0	0	0	0	0
15	14	13	12	11	10	9	8
NXT_DESC_ADDR							
rwu							
0	0	0	0	0	0	0	0
7	6	5	4	3	2	1	0
NXT_DESC_ADDR				-	-	-	-
rwu							
0	0	0	0				

- **NXT\_DESC\_ADDR: Next Descriptor Address**

This field contains the bits 31:4 of the 16-byte aligned address of the next channel descriptor to be processed.

Note that this field is written either by software or by descriptor loading.

## 30.8.2.18 USB Device DMA Channel X HSB Address Register (UDDMAX\_ADDR)

**Offset:** 0x0314 + (X - 1) . 0x10  
**Register Name:** UDDMAX\_ADDR, X in [1..6]  
**Access Type:** Read/Write  
**Reset Value:** 0x00000000

31	30	29	28	27	26	25	24
HSB_ADDR							
rwu							
0	0	0	0	0	0	0	0
23	22	21	20	19	18	17	16
HSB_ADDR							
rwu							
0	0	0	0	0	0	0	0
15	14	13	12	11	10	9	8
HSB_ADDR							
rwu							
0	0	0	0	0	0	0	0
7	6	5	4	3	2	1	0
HSB_ADDR							
rwu							
0	0	0	0	0	0	0	0

### • HSB\_ADDR: HSB Address

This field determines the HSB bus current address of a channel transfer.

The address set on the HSB address bus is HSB\_ADDR rounded down to the nearest word-aligned address, i.e. HSB\_ADDR[1:0] is considered as 00b since only word accesses are performed.

Channel HSB start and end addresses may be aligned on any byte boundary.

The software may write this field only when the Channel Enabled bit (CH\_EN) of the UDDMAX\_STATUS register is clear.

This field is updated at the end of the address phase of the current access to the HSB bus. It is incremented of the HSB access byte-width.

The HSB access width is 4 bytes, or less at packet start or end if the start or end address is not aligned on a word boundary.

The packet start address is either the channel start address or the next channel address to be accessed in the channel buffer.

The packet end address is either the channel end address or the latest channel address accessed in the channel buffer.

The channel start address is written by software or loaded from the descriptor, whereas the channel end address is either determined by the end of buffer or the end of USB transfer if the Buffer Close Input Enable bit (BUFF\_CLOSE\_IN\_EN) is set.



## 30.8.2.19 USB Device DMA Channel X Control Register (UDDMAX\_CONTROL)

**Offset:** 0x0318 + (X - 1) . 0x10  
**Register Name:** UDDMAX\_CONTROL, X in [1..6]  
**Access Type:** Read/Write  
**Reset Value:** 0x00000000

31	30	29	28	27	26	25	24
CH_BYTE_LENGTH							
rwu							
0	0	0	0	0	0	0	0
23	22	21	20	19	18	17	16
CH_BYTE_LENGTH							
rwu							
0	0	0	0	0	0	0	0
15	14	13	12	11	10	9	8
-	-	-	-	-	-	-	-

7	6	5	4	3	2	1	0
BURST_LOCK_EN	DESC_LD_IRQ_EN	EOBUFF_IRQ_EN	EOT_IRQ_EN	DMAEND_EN	BUFF_CLOSE_IN_EN	LD_NXT_CH_DESC_EN	CH_EN
rwu							
0	0	0	0	0	0	0	0

- **CH\_EN: Channel Enable**

Set this bit to enable this channel data transfer.

Clear this bit to disable the channel data transfer.

This may be used to start or resume any requested transfer.

This bit is cleared by hardware when the HSB source channel is disabled at end of dma buffer.

- **LD\_NXT\_CH\_DESC\_EN: Load Next Channel Descriptor Enable**

Set this bit to allow automatic next descriptor loading at the end of the channel transfer.

Clear this bit to disable this feature.

If set, the dma channel controller loads the next descriptor when the UDDMAX\_STATUS.CH\_EN bit is reset due to software of hardware event (for example at the end of the current transfer).

- **BUFF\_CLOSE\_IN\_EN: Buffer Close Input Enable**

Set this bit to automatically closed the current dma transfer at the end of the usb OUT data transfer (received short packet).

Clear this bit to disable this feature.

- **DMAEND\_EN: End of DMA Buffer Output Enable**

Set this bit to properly complete the usb transfer at the end of the dma transfer.

For IN endpoint, it means that a short packet (or a Zero Length Packet) will be sent to the usb line to properly closed the usb transfer at the end of the dma transfer.

For OUT endpoint, it means that all the banks will be properly released. (NBUSYBK=0) at the end of the dma transfer.



- **EOT\_IRQ\_EN: End of USB Transfer Interrupt Enable**

Set this bit to enable the end of usb OUT data transfer interrupt.

This interrupt is generated only if the BUFF\_CLOSE\_IN\_EN bit is set.

Clear this bit to disable this interrupt.

- **EOBUFF\_IRQ\_EN: End of Buffer Interrupt Enable**

Set this bit to enable the end of buffer interrupt.

This interrupt is generated when the channel byte count reaches zero.

Clear this bit to disable this interrupt.

- **DESC\_LD\_IRQ\_EN: Descriptor Loaded Interrupt Enable**

Set this bit to enable the Descriptor Loaded interrupt.

This interrupt is generated when a Descriptor has been loaded from the system bus.

Clear this bit to disable this interrupt.

- **BURST\_LOCK\_EN: Burst Lock Enable**

Set this bit to lock the HSB data burst for maximum optimization of HSB busses bandwidth usage and maximization of fly-by duration.

If clear, the DMA never locks HSB access.

- **CH\_BYTE\_LENGTH: Channel Byte Length**

This field determines the total number of bytes to be transferred for this buffer.

The maximum channel transfer size 64 kB is reached when this field is 0 (default value).

If the transfer size is unknown, the transfer end is controlled by the peripheral and this field should be set to 0.

This field can be written by software or descriptor loading only after the UDDMAX\_STATUS.CH\_EN bit has been cleared, otherwise this field is ignored.

## 30.8.2.20 USB Device DMA Channel X Status Register (UDDMAX\_STATUS)

**Offset:** 0x031C + (X - 1) . 0x10  
**Register Name:** UDDMAX\_STATUS, X in [1..6]  
**Access Type:** Read/Write  
**Reset Value:** 0x00000000

31	30	29	28	27	26	25	24
CH_BYTE_CNT							
ru							
0	0	0	0	0	0	0	0
23	22	21	20	19	18	17	16
CH_BYTE_CNT							
ru							
0	0	0	0	0	0	0	0
15	14	13	12	11	10	9	8
-	-	-	-	-	-	-	-
7	6	5	4	3	2	1	0
-	DESC_LD_STA	EOCH_BUFF_STA	EOT_STA	-	-	CH_ACTIVE	CH_EN
	ru	ru	ru			rwu	rwu
	0	0	0			0	0

- **CH\_EN: Channel Enabled**

If set, the DMA channel is currently enabled.

If cleared, the DMA channel does no longer transfer data.

- **CH\_ACTIVE: Channel Active**

If set, the DMA channel is currently trying to source USB data.

If cleared, the DMA channel is no longer trying to source USB data.

When a USB data transfer is completed, this bit is automatically reset.

- **EOT\_STA: End of USB Transfer Status**

Set by hardware when the completion of the usb data transfer has closed the dma transfer. It is valid only if BUFF\_CLOSE\_EN=1.

This bit is automatically cleared when read by software.

- **EOCH\_BUFF\_STA: End of Channel Buffer Status**

Set by hardware when the Channel Byte Count downcounts to zero.

This bit is automatically cleared when read by software.

- **DESC\_LD\_STA: Descriptor Loaded Status**

Set by hardware when a Descriptor has been loaded from the HSB bus.

This bit is automatically cleared when read by software.

- **CH\_BYTE\_CNT: Channel Byte Count**

This field gives the current number of bytes still to be transferred for this buffer.

This field is decremented at each dma access.

This field is reliable (stable) only if the CH\_EN flag is 0.

## 30.8.3 USB Host Registers

### 30.8.3.1 USB Host General Control Register (UHCON)

**Offset:** 0x0400  
**Register Name:** UHCON  
**Access Type:** Read/Write  
**Reset Value:** 0x00000000

31	30	29	28	27	26	25	24
-	-	-	-	-	-	-	-
23	22	21	20	19	18	17	16
-	-	-	-	-	-	-	-
15	14	13	12	11	10	9	8
-	-	-	-	-	RESUME	RESET	SOFE
					rwu	rwu	rwu
					0	0	0
7	6	5	4	3	2	1	0
-	-	-	-	-	-	-	-

- **SOFE: Start of Frame Generation Enable**

Set this bit to generate SOF on the USB bus in full speed mode and keep alive in low speed mode.

Clear this bit to disable the SOF generation and to leave the USB bus in idle state.

This bit is set by hardware when a USB reset is requested or an upstream resume interrupt is detected (UHINT.TXRSMI).

- **RESET: Send USB Reset**

Set this bit to generate a USB Reset on the USB bus.

Cleared by hardware when the USB Reset has been sent.

It may be useful to clear this bit by software when a device disconnection is detected (UHINT.DDISCI is set) whereas a USB Reset is being sent.

- **RESUME: Send USB Resume**

Set this bit to generate a USB Resume on the USB bus.

Cleared by hardware when the USB Resume has been sent or when a USB reset is requested. Clearing by software has no effect. This bit should be set only when the start of frame generation is enable. (SOFE bit set).

## 30.8.3.2 USB Host Global Interrupt Register (UHINT)

**Offset:** 0x0404  
**Register Name:** UHINT  
**Access Type:** Read-Only  
**Reset Value:** 0x00000000

31	30	29	28	27	26	25	24
–	DMA6INT	DMA5INT	DMA4INT	DMA3INT	DMA2INT	DMA1INT	–
	r	r	r	r	r	r	
	0	0	0	0	0	0	
23	22	21	20	19	18	17	16
–	–	–	–	–	–	–	–

15	14	13	12	11	10	9	8
–	P6INT	P5INT	P4INT	P3INT	P2INT	P1INT	P0INT
	r	r	r	r	r	r	r
	0	0	0	0	0	0	0
7	6	5	4	3	2	1	0
–	HWUPI	HSOFI	RXRSMI	RSMEDI	RSTI	DDISCI	DCONNI
	r	r	r	r	r	r	r
	0	0	0	0	0	0	0

- **DCONNI: Device Connection Interrupt Flag**

Set by hardware when a new device has been connected to the USB bus.

Shall be cleared by software (by setting the DCONNIC bit).

- **DDISCI: Device Disconnection Interrupt Flag**

Set by hardware when the device has been removed from the USB bus.

Shall be cleared by software (by setting the DDISCIC bit).

- **RSTI: USB Reset Sent Interrupt Flag**

Set by hardware when a USB Reset has been sent to the device.

Shall be cleared by software (by setting the RSTIC bit).

- **RSMEDI: Downstream Resume Sent Interrupt Flag**

Set by hardware when a Downstream Resume has been sent to the Device.

Shall be cleared by software (by setting the RSMEDIC bit).

- **RXRSMI: Upstream Resume Received Interrupt Flag**

Set by hardware when an Upstream Resume has been received from the Device.

Shall be cleared by software (by setting the RXRSMIC bit).

- **HSOFI: Host Start of Frame Interrupt Flag**

Set by hardware when a SOF is issued by the Host controller. This triggers a USB interrupt when HSOFI is set. When using the host controller in low speed mode, this bit is also set when a keep-alive is sent.

Shall be cleared by software (by setting the HSOFIC bit).

- **HWUPI: Host Wake-Up Interrupt Flag**

Asynchronous interrupt.

Set by hardware in the following cases :

- The Host controller is in the suspend mode (SOFE=0) and an upstream resume from the Peripheral is detected.
- The Host controller is in the suspend mode (SOFE=0) and a Peripheral disconnection is detected.
- The Host controller is in the Idle state (VBUSRQ=0, no VBus is generated), and an OTG SRP event initiated by the Peripheral is detected.

Note that this interrupt is generated even if the clock is frozen by the FRZCLK bit.

- **PXINT, X in [0..6]: Pipe X Interrupt Flag**

Set by hardware when an interrupt is triggered by the endpoint X (UPSTAX). This triggers a USB interrupt if the corresponding pipe interrupt enable bit is set (UHINTE register). Cleared by hardware when the interrupt source is served.

- **DMAXINT, X in [1..6]: DMA Channel X Interrupt Flag**

Set by hardware when an interrupt is triggered by the DMA channel X. This triggers a USB interrupt if the corresponding DMAXINTE is set (UHINTE register).

Cleared by hardware when the UHDMAX\_STATUS interrupt source is cleared.

### 30.8.3.3 USB Host Global Interrupt Clear Register (UHINTCLR)

**Offset:** 0x0408  
**Register Name:** UHINTCLR  
**Access Type:** Write-Only  
**Read Value:** 0x00000000

31	30	29	28	27	26	25	24
-	-	-	-	-	-	-	-

23	22	21	20	19	18	17	16
-	-	-	-	-	-	-	-

15	14	13	12	11	10	9	8
-	-	-	-	-	-	-	-

7	6	5	4	3	2	1	0
-	HWUPIC	HOFIC	RXRSMIC	RSMEDIC	RSTIC	DDISCIC	DCONNIC
	w	w	w	w	w	w	w
	0	0	0	0	0	0	0

- **DCONNIC: Device Connection Interrupt Flag Clear**

Set to clear DCONNI.

Clearing has no effect.

Always read as 0.

- **DDISCIC: Device Disconnection Interrupt Flag Clear**

Set to clear DDISCI.

Clearing has no effect.

Always read as 0.

- **RSTIC: USB Reset Sent Interrupt Flag Clear**

Set to clear RSTI.

Clearing has no effect.

Always read as 0.

- **RSMEDIC: Downstream Resume Sent Interrupt Flag Clear**

Set to clear RSMEDI.

Clearing has no effect.

Always read as 0.

- **RXRSMIC: Upstream Resume Received Interrupt Flag Clear**

Set to clear RXRSMI.



Clearing has no effect.

Always read as 0.

- **HSOFIC: Host Start of Frame Interrupt Flag Clear**

Set to clear HSOFI.

Clearing has no effect.

Always read as 0.

- **HWUPIC: Host Wake-Up Interrupt Flag Clear**

Set to clear HWUPI.

Clearing has no effect.

Always read as 0.

## 30.8.3.4 USB Host Global Interrupt Set Register (UHINTSET)

**Offset:** 0x040C  
**Register Name:** UHINTSET  
**Access Type:** Write-Only  
**Read Value:** 0x00000000

31	30	29	28	27	26	25	24
–	DMA6INTS	DMA5INTS	DMA4INTS	DMA3INTS	DMA2INTS	DMA1INTS	–
	w	w	w	w	w	w	
	0	0	0	0	0	0	
23	22	21	20	19	18	17	16
–	–	–	–	–	–	–	–
15	14	13	12	11	10	9	8
–	–	–	–	–	–	–	–
7	6	5	4	3	2	1	0
–	HWUPIS	HSOFIS	RXRSMIS	RSMEDIS	RSTIS	DDISCIS	DCONNIS
	w	w	w	w	w	w	w
	0	0	0	0	0	0	0

- **DCONNIS: Device Connection Interrupt Flag Set**

Set to set DCONNIS, what may be useful for test or debug purposes.

Clearing has no effect.

Always read as 0.

- **DDISCIS: Device Disconnection Interrupt Flag Set**

Set to set DDISCIS, what may be useful for test or debug purposes.

Clearing has no effect.

Always read as 0.

- **RSTIS: USB Reset Sent Interrupt Flag Set**

Set to set RSTIS, what may be useful for test or debug purposes.

Clearing has no effect.

Always read as 0.

- **RSMEDIS: Downstream Resume Sent Interrupt Flag Set**

Set to set RSMEDIS, what may be useful for test or debug purposes.

Clearing has no effect.

Always read as 0.

- **RXRSMIS: Upstream Resume Received Interrupt Flag Set**

Set to set RXRSMIS, what may be useful for test or debug purposes.

Clearing has no effect.

Always read as 0.

- **HSOFIS: Host Start of Frame Interrupt Flag Set**

Set to set HSOFI, what may be useful for test or debug purposes.

Clearing has no effect.

Always read as 0.

- **HWUPIS: Host Wake-Up Interrupt Flag Set**

Set to set HWUPI, what may be useful for test or debug purposes.

Clearing has no effect.

Always read as 0.

- **DMAXINTS, X in [1..6]: DMA Channel X Interrupt Flag Set**

Set to set DMAXINT, what may be useful for test or debug purposes.

Clearing has no effect.

Always read as 0.

## 30.8.3.5 USB Host Global Interrupt Enable Register (UHINTE)

**Offset:** 0x0410  
**Register Name:** UHINTE  
**Access Type:** Read-Only  
**Reset Value:** 0x00000000

31	30	29	28	27	26	25	24
–	DMA6INTE	DMA5INTE	DMA4INTE	DMA3INTE	DMA2INTE	DMA1INTE	–
	r	r	r	r	r	r	
	0	0	0	0	0	0	
23	22	21	20	19	18	17	16
–	–	–	–	–	–	–	–

15	14	13	12	11	10	9	8
–	P6INTE	P5INTE	P4INTE	P3INTE	P2INTE	P1INTE	POINTE
	r	r	r	r	r	r	r
	0	0	0	0	0	0	0
7	6	5	4	3	2	1	0
–	HWUPIE	HSOFIE	RXRSMIE	RSMEDIE	RSTIE	DDISCIE	DCONNIE
	r	r	r	r	r	r	r
	0	0	0	0	0	0	0

- **DCONNIE: Device Connection Interrupt Enable**

Set by software (by setting the DCONNIES bit) to enable the Device Connection interrupt (DCONNI).

Clear by software (by setting the DCONNIEC bit) to disable the Device Connection interrupt (DCONNI).

- **DDISCIE: Device Disconnection Interrupt Enable**

Set by software (by setting the DDISCIES bit) to enable the Device Disconnection interrupt (DDISCI).

Clear by software (by setting the DDISCIEC bit) to disable the Device Disconnection interrupt (DDISCI).

- **RSTIE: USB Reset Sent Interrupt Enable**

Set by software (by setting the RSTIES bit) to enable the USB Reset Sent interrupt (RSTI).

Clear by software (by setting the RSTIEC bit) to disable the USB Reset Sent interrupt (RSTI).

- **RSMEDIE: Downstream Resume Sent Interrupt Enable**

Set by software (by setting the RSMEDIES bit) to enable the Downstream Resume interrupt (RSMEDI).

Clear by software (by setting the RSMEDIEC bit) to disable the Downstream Resume interrupt (RSMEDI).

- **RXRSMIE: Upstream Resume Received Interrupt Enable**

Set by software (by setting the RXRSMIES bit) to enable the Upstream Resume Received interrupt (RXRSMI).

Clear by software (by setting the RXRSMIEC bit) to disable the Downstream Resume interrupt (RXRSMI).

- **HSOFIE: Host Start of Frame Interrupt Enable**

Set by software (by setting the HSOFIES bit) to enable the Host Start of Frame interrupt (HSOFI).

Clear by software (by setting the HSOFIEC bit) to disable the Host Start of Frame interrupt (HSOFI).

- **HWUPIE: Host Wake-Up Interrupt Enable**

Set by software (by setting the HWUPIES bit) to enable the Host Wake-up Interrupt (HWUPI).

Clear by software (by setting the HWUPIEC bit) to disable the Host Wake-up Interrupt (HWUPI).

- **PXINTE, X in [0..6]: Pipe X Interrupt Enable**

Set by software (by setting the PXINTES bit) to enable the Pipe X Interrupt (PXINT).

Clear by software (by setting the PXINTEC bit) to disable the Pipe X Interrupt (PXINT).

- **DMAXINTE, X in [1..6]: DMA Channel X Interrupt Enable**

Set by software (by setting the DMAXINTES bit) to enable the DMA Channel X Interrupt (DMAXINT).

Clear by software (by setting the DMAXINTEC bit) to disable the DMA Channel X Interrupt (DMAXINT).

## 30.8.3.6 USB Host Global Interrupt Enable Clear Register (UHINTECLR)

**Offset:** 0x0414  
**Register Name:** UHINTECLR  
**Access Type:** Write-Only  
**Read Value:** 0x00000000

31	30	29	28	27	26	25	24
–	DMA6INTEC	DMA5INTEC	DMA4INTEC	DMA3INTEC	DMA2INTEC	DMA1INTEC	–
	w	w	w	w	w	w	
	0	0	0	0	0	0	
23	22	21	20	19	18	17	16
–	–	–	–	–	–	–	–

15	14	13	12	11	10	9	8
–	P6INTEC	P5INTEC	P4INTEC	P3INTEC	P2INTEC	P1INTEC	P0INTEC
	w	w	w	w	w	w	w
	0	0	0	0	0	0	0
7	6	5	4	3	2	1	0
–	HWUPIEC	HSOFIEC	RXRSMIEC	RSMEDIEC	RSTIEC	DDISCIEC	DCONNIEC
	w	w	w	w	w	w	w
	0	0	0	0	0	0	0

- **DCONNIEC: Device Connection Interrupt Enable Clear**

Set to clear DCONNIE.

Clearing has no effect.

Always read as 0.

- **DDISCIEC: Device Disconnection Interrupt Enable Clear**

Set to clear DDISCIEC.

Clearing has no effect.

Always read as 0.

- **RSTIEC: USB Reset Sent Interrupt Enable Clear**

Set to clear RSTIEC.

Clearing has no effect.

Always read as 0.

- **RSMEDIEC: Downstream Resume Sent Interrupt Enable Clear**

Set to clear RSMEDIEC.

Clearing has no effect.

Always read as 0.

- **RXRSMIEC: Upstream Resume Received Interrupt Enable Clear**

Set to clear RSTIEC.

Clearing has no effect.

Always read as 0.

- **HSOFIEC: Host Start of Frame Interrupt Enable Clear**

Set to clear HSOFIEC.

Clearing has no effect.

Always read as 0.

- **HWUPIEC: Host Wake-Up Interrupt Enable Clear**

Set to clear HWUPIEC.

Clearing has no effect.

Always read as 0.

- **PXINTEC, X in [0..6]: Pipe X Interrupt Enable Clear**

Set to clear PXINTEC.

Clearing has no effect.

Always read as 0.

- **DMAXINTEC, X in [1..6]: DMA Channel X Interrupt Enable Clear**

Set to clear DMAXINTEC.

Clearing has no effect.

Always read as 0.

## 30.8.3.7 USB Host Global Interrupt Enable Set Register (UHINTESET)

**Offset:** 0x0418  
**Register Name:** UHINTESET  
**Access Type:** Write-Only  
**Read Value:** 0x00000000

31	30	29	28	27	26	25	24
–	DMA6INTES	DMA5INTES	DMA4INTES	DMA3INTES	DMA2INTES	DMA1INTES	–
	w	w	w	w	w	w	
	0	0	0	0	0	0	
23	22	21	20	19	18	17	16
–	–	–	–	–	–	–	–

15	14	13	12	11	10	9	8
–	P6INTES	P5INTES	P4INTES	P3INTES	P2INTES	P1INTES	POINTES
	w	w	w	w	w	w	w
	0	0	0	0	0	0	0
7	6	5	4	3	2	1	0
–	HWUPIES	HSOFIES	RXRSMIES	RSMEDIES	RSTIES	DDISCIES	DCONNIES
	w	w	w	w	w	w	w
	0	0	0	0	0	0	0

- **DCONNIES: Device Connection Interrupt Enable Set**

Set to set DCONNIE.

Clearing has no effect.

Always read as 0.

- **DDISCIES: Device Disconnection Interrupt Enable Set**

Set to set DDISCIE.

Clearing has no effect.

Always read as 0.

- **RSTIES: USB Reset Sent Interrupt Enable Set**

Set to set RSTIE.

Clearing has no effect.

Always read as 0.

- **RSMEDIES: Downstream Resume Sent Interrupt Enable Set**

Set to set RSMEDIE.

Clearing has no effect.

Always read as 0.

- **RXRSMIES: Upstream Resume Received Interrupt Enable Set**

Set to set RXRSMIE.



Clearing has no effect.

Always read as 0.

- **HSOFIES: Host Start of Frame Interrupt Enable Set**

Set to set HSOFIE.

Clearing has no effect.

Always read as 0.

- **HWUPIES: Host Wake-Up Interrupt Enable Set**

Set to set HWUPIE.

Clearing has no effect.

Always read as 0.

- **PXINTES, X in [0..6]: Pipe X Interrupt Enable Set**

Set to set PXINTE.

Clearing has no effect.

Always read as 0.

- **DMAXINTES, X in [1..6]: DMA Channel X Interrupt Enable Set**

Set to set DMAXINTE.

Clearing has no effect.

Always read as 0.

## 30.8.3.8 USB Host Frame Number Register (UHFNUM)

**Offset:** 0x0420  
**Register Name:** UHFNUM  
**Access Type:** Read/Write  
**Reset Value:** 0x00000000

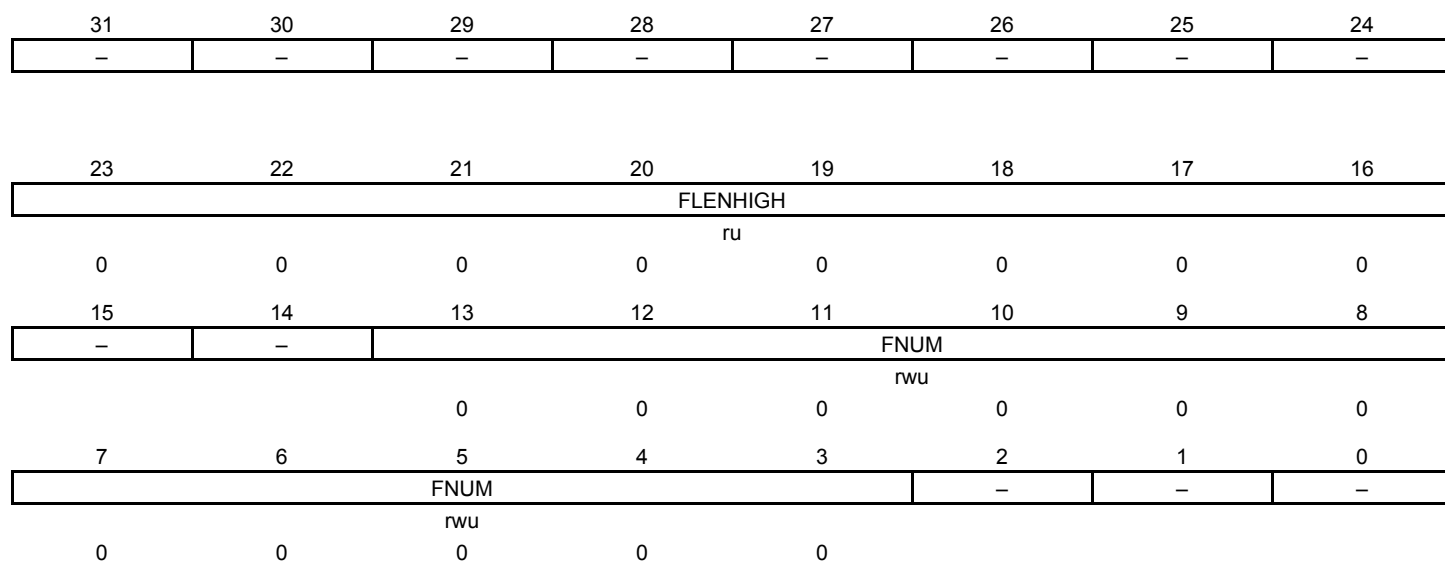

- **FNUM: Frame Number**

The value contained in this register is the current SOF number.

This value can be modified by software.

- **FLENHIGH: Frame Length**

This register gives the 8 high-order bits of the 14-bits internal frame counter (frame counter at 12 Mhz, counter length is 12000 to ensure a SOF generation every 1 ms).

## 30.8.3.9 USB Host Frame Number Register (UHADDR1)

**Offset:** 0x0424  
**Register Name:** UHADDR1  
**Access Type:** Read/Write  
**Reset Value:** 0x00000000

31	30	29	28	27	26	25	24
–	UHADDR_P3						
				rwu			
–	0	0	0	0	0	0	0
23	22	21	20	19	18	17	16
–	UHADDR_P2						
				rwu			
–	0	0	0	0	0	0	0
15	14	13	12	11	10	9	8
–	UHADDR_P1						
				rwu			
–	0	0	0	0	0	0	0
7	6	5	4	3	2	1	0
–	UHADDR_P0						
				rwu			
–	0	0	0	0	0	0	0

- **UHADDR\_P0 : USB Host Address**

These bits should contain the address of the Pipe0 of the USB Device.

Cleared by hardware when a USB reset is requested.

- **UHADDR\_P1 : USB Host Address**

These bits should contain the address of the Pipe1 of the USB Device.

Cleared by hardware when a USB reset is requested.

- **UHADDR\_P2 : USB Host Address**

These bits should contain the address of the Pipe2 of the USB Device.

Cleared by hardware when a USB reset is requested.

- **UHADDR\_P3 : USB Host Address**

These bits should contain the address of the Pipe3 of the USB Device.

Cleared by hardware when a USB reset is requested.

## 30.8.3.10 USB Host Frame Number Register (UHADDR2)

**Offset:** 0x0428  
**Register Name:** UHADDR2  
**Access Type:** Read/Write  
**Reset Value:** 0x00000000

31	30	29	28	27	26	25	24
–	–	–	–	–	–	–	–
				rwu			
–	0	0	0	0	0	0	0
23	22	21	20	19	18	17	16
–	UHADDR_P6						
				rwu			
–	0	0	0	0	0	0	0
15	14	13	12	11	10	9	8
–	UHADDR_P5						
				rwu			
–	0	0	0	0	0	0	0
7	6	5	4	3	2	1	0
–	UHADDR_P4						
				rwu			
–	0	0	0	0			

- **UHADDR\_P4 : USB Host Address**

These bits should contain the address of the Pipe4 of the USB Device.

Cleared by hardware when a USB reset is requested.

- **UHADDR\_P5 : USB Host Address**

These bits should contain the address of the Pipe5 of the USB Device.

Cleared by hardware when a USB reset is requested.

- **UHADDR\_P6 : USB Host Address**

These bits should contain the address of the Pipe6 of the USB Device.

Cleared by hardware when a USB reset is requested.

- **UHADDR\_P7 : USB Host Address**

These bits should contain the address of the Pipe7 of the USB Device.

Cleared by hardware when a USB reset is requested.

## 30.8.3.11 USB Pipe Enable/Reset Register (UPRST)

**Offset:** 0x0041C  
**Register Name:** UPRST  
**Access Type:** Read/Write  
**Reset Value:** 0x00000000

31	30	29	28	27	26	25	24
-	-	-	-	-	-	-	-

23	22	21	20	19	18	17	16
-	PRST6	PRST5	PRST4	PRST3	PRST2	PRST1	PRST0
	rwu	rwu	rwu	rwu	rwu	rwu	rwu
	0	0	0	0	0	0	0
15	14	13	12	11	10	9	8
-	-	-	-	-	-	-	-

7	6	5	4	3	2	1	0
-	PEN6	PEN5	PEN4	PEN3	PEN2	PEN1	PEN0
	rw	rw	rw	rw	rw	rw	rw
	0	0	0	0	0	0	0

- **PENX, X in [0..6]: Pipe X Enable**

Set to enable the Pipe X.

Clear to disable the Pipe X, what forces the Pipe X state to inactive and resets the pipe X registers (UPCFGX, UPSTAX, UPCONX) but not the pipe configuration (ALLOC, PBK, PSIZE).

- **PRSTX, X in [0..6]: Pipe X Reset**

Set by software to reset the Pipe X FIFO.

This resets the endpoint X registers (UPCFGX, UPSTAX, UPCONX) but not the endpoint configuration (ALLOC, PBK, PSIZE, PTOKEN, PTYPE, PEPNUM, INTFRQ).

All the endpoint mechanism (FIFO counter, reception, transmission, etc.) is reset apart from the Data Toggle management

The endpoint configuration remains active and the endpoint is still enabled.

Then, clear by software to complete the reset operation and to start using the FIFO.

### 30.8.3.12 USB Pipe X Configuration Register (UPCFGX)

**Offset:** 0x0500 + X . 0x04  
**Register Name:** UPCFGX, X in [0..6]  
**Access Type:** Read/Write  
**Reset Value:** 0x00000000

31	30	29	28	27	26	25	24
INTFRQ							
rwu							
0	0	0	0	0	0	0	0
23	22	21	20	19	18	17	16
-				PEPNUM			
rwu							
				0	0	0	0
15	14	13	12	11	10	9	8
-		PTYPE		-		PTOKEN	
		rwu				rwu	
		0	0			0	0
7	6	5	4	3	2	1	0
-		PSIZE		PBK		ALLOC	
		rwu		rwu		rwu	
		0	0	0	0	0	0

• **ALLOC: Pipe Memory Allocate**

Set to configure the pipe memory with the characteristics.

Clear to update the memory allocation.

This bit is cleared by hardware when a USB Reset is requested.

Refer to the DPRAM Management chapter for more details.

• **PBK: Pipe Banks**

Set to select the number of banks for the pipe:

PBK		Endpoint Banks
0	0	1 (single-bank pipe)
0	1	2 (double-bank pipe)
1	0	3 (triple-bank pipe)
1	1	Reserved

For control endpoints, a single-bank pipe (00b) should be selected.

Cleared by hardware upon sending a USB reset.

- **PSIZE: Pipe Size**

Set to select the size of each pipe bank:

PSIZE			Endpoint Size
0	0	0	8 bytes
0	0	1	16 bytes
0	1	0	32 bytes
0	1	1	64 bytes
1	0	0	128 bytes
1	0	1	256 bytes
1	1	0	512 bytes
1	1	1	1024 bytes

Cleared by hardware upon sending a USB reset.

- **PTOKEN: Pipe Token**

Set to select the endpoint token:

PTOKEN	Endpoint Direction
00	SETUP
01	IN
10	OUT
11	reserved

- **AUTOSW: Automatic Switch**

Set to automatically switch bank when it is ready.

Clear to disable the automatic bank switching.

Cleared by hardware upon sending a USB reset.

- **PTYPE: Pipe Type**

Set to select the pipe type:

PTYPE		Pipe Type
0	0	Control
0	1	Isochronous
1	0	Bulk
1	1	Interrupt

Cleared by hardware upon sending a USB reset.

- **PEPNUM: Pipe Endpoint Number**

Set this field according to the Pipe configuration. Set the number of the endpoint targeted by the pipe. This value is from 0 to 15.

Cleared by hardware upon sending a USB reset.

- **INTFRQ: Pipe Interrupt Request Frequency**

These bits are the maximum value in millisecond of the polling period for an Interrupt Pipe.

This value has no effect for a non-Interrupt Pipe.

Cleared by hardware upon sending a USB reset.



### 30.8.3.13 USB Pipe X Status Register (UPSTAX)

**Offset:** 0x0530 + X . 0x04  
**Register Name:** UPSTAX, X in [0..6]  
**Access Type:** Read-Only  
**Reset Value:** 0x00000000

31	30	29	28	27	26	25	24
-		PBYCT					
		r					
0		0	0	0	0	0	0
23	22	21	20	19	18	17	16
PBYCT			-	CFGOK	-	RWALL	
r				r		r	
0	0	0	0		0		0
15	14	13	12	11	10	9	8
CURRBK		NBUSYBK		-	-	DTSEQ	
r		r				r	
0	0	0	0			0	0
7	6	5	4	3	2	1	0
SHORT PACKETI	RXSTALLDI/ CRCERRI	OVERFI	NAKEDI	PERRI	TXSTPI/ UNDERFI	TXOUTI	RXINI
r	r	r	r	r	r	r	r
0	0	0	0	0	0	0	0

- **RXINI: Received IN Data Interrupt Flag**

Set by hardware when a new USB message is stored in the current bank of the Pipe. This triggers an interrupt if the RXINE bit is set. Shall be cleared by software (by setting the RXINIC bit).

- **TXOUTI: Transmitted OUT Data Interrupt Flag**

Set by hardware when the current OUT bank is free and can be filled. This triggers an interrupt if the TXOUTE bit is set. Shall be cleared by software (by setting the TXOUTIC bit).

- **TXSTPI: Transmitted SETUP Interrupt Flag**

For Control endpoints. Set by hardware when the current SETUP bank is free and can be filled. This triggers an interrupt if the TXSTPE bit is set. Shall be cleared by software (by setting the TXSTPIC bit).

- **UNDERFI: Underflow Interrupt Flag**

Set by hardware when a transaction underflow occurs in the current isochronous or interrupt pipe. (the pipe can't send the OUT data packet in time because the current bank is not ready). A zero-length-packet (ZLP) will be send instead of. This triggers an interrupt if the UNDERFLE bit is set. Shall be cleared by software (by setting the UNDERFIC bit).

- **PERRI: Pipe Error Interrupt Flag**

Set by hardware when an error occurs on the current bank of the Pipe. This triggers an interrupt if the PERRE bit is set. Refers to the UPERRX register to determine the source of the error. Automatically cleared by hardware when the error source bit is cleared.

- **NAKEDI: NAKed Interrupt Flag**

Set by hardware when a NAK has been received on the current bank of the Pipe. This triggers an interrupt if the NAKEDE bit is set. Shall be cleared by software (by setting the NAKEDIC bit).

- **OVERFI: Overflow Interrupt Flag**

Set by hardware when the current Pipe has received more data than the maximum length of the current Pipe. An interrupt is triggered if the OVERFIE bit is set. Shall be cleared by software (by setting the OVERFIC bit).

- **RXSTALLDI: Received STALLed Interrupt Flag**

For all endpoints but isochronous. Set by hardware when a STALL handshake has been received on the current bank of the Pipe. The Pipe is automatically frozen. This triggers an interrupt if the RXSTALLE bit is set. Shall be cleared to handshake the interrupt (by setting the RXSTALLDIC bit).

- **CRCERRI: CRC Error Interrupt Flag**

For isochronous endpoint, set by hardware when a CRC error occurs on the current bank of the Pipe. This triggers an interrupt if the TXSTPE bit is set. Shall be cleared to handshake the interrupt (by setting the CRCERRIC bit).

- **SHORTPACKETI: Short Packet Interrupt Flag**

Set by hardware when a short packet is received by the host controller (packet length inferior to the PSIZE programmed field). Shall be cleared to handshake the interrupt (by setting the SHORTPACKETIC bit).

- **DTSEQ: Data Toggle Sequence**

Set by hardware to indicate the data PID of the current bank.

DTSEQ		Data toggle sequence
0	0	Data0
0	1	Data1
1	0	reserved
1	1	reserved

For OUT pipe, this field indicates the data toggle of the next packet that will be sent.

For IN pipe, this field indicates the data toggle of the received packet stored in the current bank.

- **NBUSYBK: Number of Busy Banks**

Set by hardware to indicate the number of busy bank.

For OUT Pipe, it indicates the number of busy bank(s), filled by the user, ready for OUT transfer. When all banks are busy, this triggers an PXINT interrupt if UPCONX.NBUSYBKE = 1.

For IN Pipe, it indicates the number of busy bank(s) filled by IN transaction from the Device. When all banks are free, this triggers an PXINT interrupt if UPCONX.NBUSYBKE = 1..

NBUSYBK		Number of busy bank
0	0	All banks are free.
0	1	1 busy bank
1	0	2 busy banks
1	1	reserved

- **CURRBK: Current Bank**

For non-control pipe, set by hardware to indicate the number of the current bank.

CURRBK		Current Bank
0	0	Bank0
0	1	Bank1
1	0	Bank2
1	1	Reserved

Note that this field may be updated 1 clock cycle after the RWALL bit changes, so the user should not poll this field as an interrupt flag.

- **RWALL: Read/Write Allowed**

For OUT pipe, set by hardware when the current bank is not full, i.e. the software can write further data into the FIFO.

For IN pipe, set by hardware when the current bank is not empty, i.e. the software can read further data from the FIFO.

Cleared by hardware otherwise.

This bit is also cleared by hardware when the RXSTALL or the PERR bit is set.

- **CFGOK: Configuration OK Status**

This bit is updated when the ALLOC bit is set.

Set by hardware if the pipe X number of banks (PBK) and size (PSIZE) are correct compared to the maximal allowed number of banks and size for this pipe and to the maximal FIFO size (i.e. the DPRAM size).

If this bit is cleared by hardware, the user should reprogram the UPCFGX register with correct PBK and PSIZE values.

- **PBYCT: Pipe Byte Count**

Set by the hardware to indicate the byte count of the FIFO.

For OUT pipe, incremented after each byte written by the software into the pipe and decremented after each byte sent to the peripheral.

For In pipe, incremented after each byte received from the peripheral and decremented after each byte read by the software from the pipe.

Note that this field may be updated 1 clock cycle after the RWALL bit changes, so the user should not poll this field as an interrupt flag.

## 30.8.3.14 USB Pipe X Status Clear Register (UPSTAXCLR)

**Offset:** 0x0560 + X . 0x04  
**Register Name:** UPSTAXCLR, X in [0..6]  
**Access Type:** Write-Only  
**Read Value:** 0x00000000

31	30	29	28	27	26	25	24
-	-	-	-	-	-	-	-

23	22	21	20	19	18	17	16
-	-	-	-	-	-	-	-

15	14	13	12	11	10	9	8
-	-	-	-	-	-	-	-

7	6	5	4	3	2	1	0
SHORT PACKETIC	RXSTALLDIC/ CRCERRIC	OVERFIC	NAKEDIC	-	TXSTPIC/ UNDERFIC	TXOUTIC	RXINIC
w	w	w	w		w	w	w
0	0	0	0		0	0	0

- **RXINIC: Received IN Data Interrupt Flag Clear**

Set to clear RXINI.

Clearing has no effect.

Always read as 0.

- **TXOUTIC: Transmitted OUT Data Interrupt Flag Clear**

Set to clear TXOUTI.

Clearing has no effect.

Always read as 0.

- **TXSTPIC: Transmitted SETUP Interrupt Flag Clear**

Set to clear TXSTPI.

Clearing has no effect.

Always read as 0.

- **UNDERFIC: Underflow Interrupt Flag Clear**

Set to clear UNDERFI.

Clearing has no effect.

Always read as 0.

- **NAKEDIC: NAKed Interrupt Flag Clear**

Set to clear NAKEDI.

Clearing has no effect.

Always read as 0.

- **OVERFIC: Overflow Interrupt Flag Clear**

Set to clear OVERFI.

Clearing has no effect.

Always read as 0.

- **RXSTALLDIC: Received STALLed Interrupt Flag Clear**

Set to clear RXSTALLDI.

Clearing has no effect.

Always read as 0.

- **CRCERRIC: CRC Error Interrupt Flag Clear**

Set to clear CRCERRI.

Clearing has no effect.

Always read as 0.

- **SHORTPACKETIC: Short Packet Interrupt Flag Clear**

Set to clear SHORTPACKETI.

Clearing has no effect.

Always read as 0.

### 30.8.3.15 USB Pipe X Status Set Register (UPSTAXSET)

**Offset:** 0x0590 + X . 0x04  
**Register Name:** UPSTAXSET, X in [0..6]  
**Access Type:** Write-Only  
**Read Value:** 0x00000000

31	30	29	28	27	26	25	24
–	–	–	–	–	–	–	–
23	22	21	20	19	18	17	16
–	–	–	–	–	–	–	–
15	14	13	12	11	10	9	8
–	–	–	NBUSYBKS	–	–	–	–
			w				
			0				
7	6	5	4	3	2	1	0
SHORT PACKETIS	RXSTALLDIS/ CRCERRIS	OVERFIS	NAKEDIS	PERRIS	TXSTPIS/ UNDERFIS	TXOUTIS	RXINIS
w	w	w	w	w	w	w	w
0	0	0	0	0	0	0	0

- **RXINIS: Received IN Data Interrupt Flag Set**  
 Set to set RXINI, what may be useful for test or debug purposes.  
 Clearing has no effect.  
 Always read as 0.
- **TXOUTIS: Transmitted OUT Data Interrupt Flag Set**  
 Set to set TXOUTI, what may be useful for test or debug purposes.  
 Clearing has no effect.  
 Always read as 0.
- **TXSTPIS: Transmitted SETUP Interrupt Flag Set**  
 Set to set TXSTPI, what may be useful for test or debug purposes.  
 Clearing has no effect.  
 Always read as 0.
- **UNDERFIS: Underflow Interrupt Flag Set**  
 Set to set UNDERFI, what may be useful for test or debug purposes.  
 Clearing has no effect.  
 Always read as 0.
- **PERRIS: Pipe Error Interrupt Flag Set**  
 Set to set PERRI, what may be useful for test or debug purposes.

Clearing has no effect.

Always read as 0.

- **NAKEDIS: NAKed Interrupt Flag Set**

Set to set NAKEDI, what may be useful for test or debug purposes.

Clearing has no effect.

Always read as 0.

- **OVERFIS: Overflow Interrupt Flag Set**

Set to set OVERFI, what may be useful for test or debug purposes.

Clearing has no effect.

Always read as 0.

- **RXSTALLDIS: Received STALLed Interrupt Flag Set**

Set to set RXSTALLDI, what may be useful for test or debug purposes.

Clearing has no effect.

Always read as 0.

- **CRCERRIS: CRC Error Interrupt Flag Set**

Set to set CRCERRI, what may be useful for test or debug purposes.

Clearing has no effect.

Always read as 0.

- **SHORTPACKETIS: Short Packet Interrupt Flag Set**

Set to set SHORTPACKETI, what may be useful for test or debug purposes.

Clearing has no effect.

Always read as 0.

- **NBUSYBKS: Number of Busy Banks Interrupt Flag Set**

Set to set NBUSYBKI, what may be useful for test or debug purposes.

Clearing has no effect.

Always read as 0.

## 30.8.3.16 USB Pipe X Control Register (UPCONX)

**Offset:** 0x05C0 + X . 0x04

**Register Name:** UPCONX, X in [0..6]

**Access Type:** Read-Only

**Reset Value:** 0x00000000

31	30	29	28	27	26	25	24
-	-	-	-	-	-	-	-
23	22	21	20	19	18	17	16
-	-	-	-	-	RSTDT	PFREEZE	PDISHDMA
					ru	ru	ru
					0	0	0
15	14	13	12	11	10	9	8
-	FIFOCON	-	NBUSYBKE	-	-	-	-
	ru		ru				
	0		0				
7	6	5	4	3	2	1	0
SHORT PACKETIE	RXSTALLDE/ CRCERRE	OVERFIE	NAKEDE	PERRE	TXSTPE/ UNDERFIE	TXOUTE	RXINE
ru	ru	ru	ru	ru	ru	ru	ru
0	0	0	0	0	0	0	0

- **RXINE: Received IN Data Interrupt Enable**

Set by software (by setting the RXINES bit) to enable the Received IN Data interrupt (RXINE).

Clear by software (by setting the RXINEC bit) to disable the Received IN Data interrupt (RXINE).

- **TXOUTE: Transmitted OUT Data Interrupt Enable**

Set by software (by setting the TXOUTES bit) to enable the Transmitted OUT Data interrupt (TXOUTE).

Clear by software (by setting the TXOUTECbit) to disable the Transmitted OUT Data interrupt (TXOUTE).

- **TXSTPE: Transmitted SETUP Interrupt Enable**

Set by software (by setting the TXSTPES bit) to enable the Transmitted SETUP interrupt (TXSTPE).

Clear by software (by setting the TXSTPEC bit) to disable the Transmitted SETUP interrupt (TXSTPE).

- **UNDERFIE: Underflow Interrupt Enable**

Set by software (by setting the UNDERFIES bit) to enable the Underflow interrupt (UNDERFIE).

Clear by software (by setting the UNDERFIEC bit) to disable the Underflow interrupt (UNDERFIE).

- **PERRE: Pipe Error Interrupt Enable**

Set by software (by setting the PERRES bit) to enable the Pipe Error interrupt (PERRE).

Clear by software (by setting the PERREC bit) to disable the Pipe Error interrupt (PERRE).

- **NAKEDE: NAKed Interrupt Enable**

Set by software (by setting the NAKEDES bit) to enable the NAKed interrupt (NAKEDE).

Clear by software (by setting the NAKEDEC bit) to disable the NAKed interrupt (NAKEDE).



- **OVERFIE: Overflow Interrupt Enable**

Set by software (by setting the OVERFIES bit) to enable the Overflow interrupt (OVERFIE).

Clear by software (by setting the OVERFIEC bit) to disable the Overflow interrupt (OVERFIE).

- **RXSTALLDE: Received STALLed Interrupt Enable**

Set by software (by setting the RXSTALLDES bit) to enable the Received STALLed interrupt (RXSTALLDE).

Clear by software (by setting the RXSTALLDEC bit) to disable the Received STALLed interrupt (RXSTALLDE).

- **CRCERRE: CRC Error Interrupt Enable**

Set by software (by setting the CRCERRES bit) to enable the CRC Error interrupt (CRCERRE).

Clear by software (by setting the CRCERREC bit) to disable the CRC Error interrupt (CRCERRE).

- **SHORTPACKETIE: Short Packet Interrupt Enable**

Set by software (by setting the SHORTPACKETES bit) to enable the Short Packet interrupt (SHORTPACKETIE).

Clear by software (by setting the SHORTPACKETEC bit) to disable the Short Packet interrupt (SHORTPACKETIE).

- **NBUSYBKE: Number of Busy Banks Interrupt Enable**

Set by software (by setting the NBUSYBKES bit) to enable the Number of Busy Banks interrupt (NBUSYBKE).

Clear by software (by setting the NBUSYBKEC bit) to disable the Number of Busy Banks interrupt (NBUSYBKE).

- **FIFOCON: FIFO Control**

For OUT and SETUP Pipe :

Set by hardware when the current bank is free, at the same time than TXOUTI or TXSTPI.

Clear by software (by setting the FIFOCONC bit) to send the FIFO data and to switch the bank.

For IN Pipe:

Set by hardware when a new IN message is stored in the current bank, at the same time than RXINI.

Clear by software (by setting the FIFOCONC bit) to free the current bank and to switch to the next bank.

- **PDISHDMA: Pipe Interrupts Disable HDMA Request Enable**

See EPDISHDMA (UECONX register).

- **PFREEZE: Pipe Freeze**

Set by software (by setting the PFREEZES bit) to Freeze the Pipe requests generation.

Clear by software (by setting the PFREEZEC bit) to enable the Pipe request generation.

This bit is set by hardware when:

- the pipe is not configured
- a STALL handshake has been received on this Pipe
- An error occurs on the Pipe (PERR = 1)
- (INRQ+1) In requests have been processed

This bit is set at 1 by hardware after a Pipe reset or a Pipe enable.

- **RSTDT: Reset Data Toggle**

Set by software (by setting the RSTDTS bit) to reset the Data Toggle to its initial value for the current Pipe.

Cleared by hardware when proceed.

## 30.8.3.17 USB Pipe X Control Clear Register (UPCONXCLR)

**Offset:** 0x0620 + X . 0x04  
**Register Name:** UPCONXCLR, X in [0..6]  
**Access Type:** Write-Only  
**Read Value:** 0x00000000

31	30	29	28	27	26	25	24
–	–	–	–	–	–	–	–
23	22	21	20	19	18	17	16
–	–	–	–	–	–	PFREEZEC	PDISHDMAC
						w	w
						0	0
15	14	13	12	11	10	9	8
–	FIFOCONC	–	NBUSYBKEC	–	–	–	–
	w		w				
	0		0				
7	6	5	4	3	2	1	0
SHORT PACKETIEC	RXSTALLDEC/ CRCERREC	OVERFIEC	NAKEDEC	PERREC	TXSTPEC/ UNDERFIEC	TXOUTEC	RXINEC
w	w	w	w	w	w	w	w
0	0	0	0	0	0	0	0

- **RXINEC: Received IN Data Interrupt Enable Clear**

Set to clear RXINE.

Clearing has no effect.

Always read as 0.

- **TXOUTEC: Transmitted OUT Data Interrupt Enable Clear**

Set to clear TXOUTE.

Clearing has no effect.

Always read as 0.

- **TXSTPEC: Transmitted SETUP Interrupt Enable Clear**

Set to clear TXSTPE.

Clearing has no effect.

Always read as 0.

- **UNDERFIEC: Underflow Interrupt Enable Clear**

Set to clear UNDERFIE.

Clearing has no effect.

Always read as 0.

- **PERREC: Pipe Error Interrupt Enable Clear**

Set to clear PERRE.

Clearing has no effect.

Always read as 0.

- **NAKEDEC: NAKed Interrupt Enable Clear**

Set to clear NAKEDE.

Clearing has no effect.

Always read as 0.

- **OVERFIEC: Overflow Interrupt Enable Clear**

Set to clear OVERFIE.

Clearing has no effect.

Always read as 0.

- **RXSTALLDEC: Received STALLed Interrupt Enable Clear**

Set to clear RXSTALLDE.

Clearing has no effect.

Always read as 0.

- **CRCERREC: CRC Error Interrupt Enable Clear**

Set to clear CRCERRE.

Clearing has no effect.

Always read as 0.

- **SHORTPACKETIEC: Short Packet Interrupt Enable Clear**

Set to clear SHORTPACKETIE.

Clearing has no effect.

Always read as 0.

- **NBUSYBKEC: Number of Busy Banks Interrupt Enable Clear**

Set to clear NBUSYBKE.

Clearing has no effect.

Always read as 0.

- **FIFOCONC: FIFO Control Clear**

Set to clear FIFOCON.

Clearing has no effect.

Always read as 0.

- **PDISHDMAC: Pipe Interrupts Disable HDMA Request Enable Clear**

Set to clear PDISHDMA.

Clearing has no effect.

Always read as 0.

- **PFREEZEC: Pipe Freeze Clear**

Set to clear PFREEZE.

Clearing has no effect.

Always read as 0.

## 30.8.3.18 USB Pipe X Control Set Register (UPCONXSET)

**Offset:** 0x05F0 + X . 0x04  
**Register Name:** UPCONXSET, X in [0..6]  
**Access Type:** Write-Only  
**Read Value:** 0x00000000

31	30	29	28	27	26	25	24
-	-	-	-	-	-	-	-
23	22	21	20	19	18	17	16
-	-	-	-	-	RSTDTS	PFREEZES	PDISHDMAS
					w	w	w
					0	0	0
15	14	13	12	11	10	9	8
-	-	-	NBUSYBKES	-	-	-	-
			w				
			0				
7	6	5	4	3	2	1	0
SHORT PACKETIES	RXSTALLDES/ CRCERRS	OVERFIES	NAKEDS	PERRES	TXSTPES/ UNDERFIES	TXOUTES	RXINES
w	w	w	w	w	w	w	w
0	0	0	0	0	0	0	0

- **RXINES: Received IN Data Interrupt Enable Set**

Set to set RXINE.

Clearing has no effect.

Always read as 0.

- **TXOUTE: Transmitted OUT Data Interrupt Enable Set**

Set to set RXINE.

Clearing has no effect.

Always read as 0.

- **TXSTPES: Transmitted SETUP Interrupt Enable Set**

Set to set TXSTPE.

Clearing has no effect.

Always read as 0.

- **UNDERFIES: Underflow Interrupt Enable Set**

Set to set UNDERFIE.

Clearing has no effect.

Always read as 0.

- **PERRES: Pipe Error Interrupt Enable Set**

Set to set PERRE.

Clearing has no effect.

Always read as 0.

- **NAKEDES: NAKed Interrupt Enable Set**

Set to set NAKEDE.

Clearing has no effect.

Always read as 0.

- **OVERFIES: Overflow Interrupt Enable Set**

Set to set OVERFIE.

Clearing has no effect.

Always read as 0.

- **RXSTALLDES: Received STALLed Interrupt Enable Set**

Set to set RXSTALLDE.

Clearing has no effect.

Always read as 0.

- **CRCERRES: CRC Error Interrupt Enable Set**

Set to set CRCERRE.

Clearing has no effect.

Always read as 0.

- **SHORTPACKETIES: Short Packet Interrupt Enable Set**

Set to set SHORTPACKETIE.

Clearing has no effect.

Always read as 0.

- **NBUSYBKES: Number of Busy Banks Interrupt Enable Set**

Set to set NBUSYBKE.

Clearing has no effect.

Always read as 0.

- **PDISHDMAS: Pipe Interrupts Disable HDMA Request Enable Set**

Set to set PDISHDMA.

Clearing has no effect.

Always read as 0.

- **PFREEZES: Pipe Freeze Set**

Set to set PFREEZE.

Clearing has no effect.

Always read as 0.

- **RSTDTS: Reset Data Toggle Set**

Set to set RSTDT.

Clearing has no effect.

Always read as 0.

## 30.8.3.19 USB Pipe X IN Request Register (UPINRQX)

**Offset:** 0x0650 + X . 0x04  
**Register Name:** UPINRQX, X in [0..6]  
**Access Type:** Read/Write  
**Reset Value:** 0x00000000

31	30	29	28	27	26	25	24
–	–	–	–	–	–	–	–
23	22	21	20	19	18	17	16
–	–	–	–	–	–	–	–
15	14	13	12	11	10	9	8
–	–	–	–	–	–	–	INMODE
							rw
							0
7	6	5	4	3	2	1	0
<div style="border: 1px solid black; padding: 2px; display: inline-block;">                 INRQ             </div>							
rwu							
0	0	0	0	0	0	0	0

- **INRQ: IN Request Number before Freeze**

Enter the number of IN transactions before the USB controller freezes the pipe. The USB controller will perform (INRQ+1) IN requests before to freeze the Pipe. This counter is automatically decreased by 1 each time a IN request has been successfully performed.

This register has no effect when the INMODE bit is set (infinite IN requests generation till the pipe is not frozen).

- **INMODE: IN Request Mode**

Set this bit to allow the USB controller to perform infinite IN requests when the Pipe is not frozen.

Clear this bit to perform a pre-defined number of IN requests. This number is the INRQ field.



## 30.8.3.20 USB Pipe X Error Register (UPERRX)

**Offset:** 0x0680 + X . 0x04  
**Register Name:** UPERRX, X in [0..6]  
**Access Type:** Read/Write  
**Reset Value:** 0x00000000

31	30	29	28	27	26	25	24
-	-	-	-	-	-	-	-
23	22	21	20	19	18	17	16
-	-	-	-	-	-	-	-
15	14	13	12	11	10	9	8
-	-	-	-	-	-	-	-
7	6	5	4	3	2	1	0
-	COUNTER		CRC16	TIMEOUT	PID	DATAPID	DATATGL
	rwu		rwu	rwu	rwu	rwu	rwu
	0	0	0	0	0	0	0

- **DATATGL: Data Toggle Error**

Set by hardware when a data toggle error has been detected.

Shall be cleared by software. Setting by software has no effect.

- **DATAPID: Data PID Error**

Set by hardware when a data PID error has been detected.

Shall be cleared by software. Setting by software has no effect.

- **PID: PID Error**

Set by hardware when a PID error has been detected.

Shall be cleared by software. Setting by software has no effect.

- **TIMEOUT: Time-Out Error**

Set by hardware when a Timeout error has been detected.

Shall be cleared by software. Setting by software has no effect.

- **CRC16: CRC16 Error**

Set by hardware when a CRC16 error has been detected.

Shall be cleared by software. Setting by software has no effect.

- **COUNTER: Error Counter**

Set by hardware when a CRC16 error has been detected.

Shall be cleared by software. Setting by software has no effect.

## 30.8.3.21 USB Host DMA Channel X Next Descriptor Address Register (UHDMAX\_NEXTDESC)

**Offset:**  $0x0710 + (X - 1) \cdot 0x10$   
**Register Name:** *UHDMAX\_NEXTDESC*, X in [1..6]  
**Access Type:** Read/Write  
**Reset Value:** 0x00000000

31	30	29	28	27	26	25	24
NXT_DESC_ADDR							
rwu							
0	0	0	0	0	0	0	0
23	22	21	20	19	18	17	16
NXT_DESC_ADDR							
rwu							
0	0	0	0	0	0	0	0
15	14	13	12	11	10	9	8
NXT_DESC_ADDR							
rwu							
0	0	0	0	0	0	0	0
7	6	5	4	3	2	1	0
NXT_DESC_ADDR				-	-	-	-
rwu							
0	0	0	0				

Same as "USB Device DMA Channel X Next Descriptor Address Register (UDDMAX\_NEXTDESC)" on page 591.

## 30.8.3.22 USB Host DMA Channel X HSB Address Register (UHDMAX\_ADDR)

**Offset:** 0x0714 + (X - 1) . 0x10  
**Register Name:** UHDMAX\_ADDR, X in [1..6]  
**Access Type:** Read/Write  
**Reset Value:** 0x00000000

31	30	29	28	27	26	25	24
HSB_ADDR							
rwu							
0	0	0	0	0	0	0	0
23	22	21	20	19	18	17	16
HSB_ADDR							
rwu							
0	0	0	0	0	0	0	0
15	14	13	12	11	10	9	8
HSB_ADDR							
rwu							
0	0	0	0	0	0	0	0
7	6	5	4	3	2	1	0
HSB_ADDR							
rwu							
0	0	0	0	0	0	0	0

Same as "USB Device DMA Channel X HSB Address Register (UDDMAX\_ADDR)" on page 592.

### 30.8.3.23 USB Host DMA Channel X Control Register (UHDMAX\_CONTROL)

**Offset:** 0x0718 + (X - 1) . 0x10  
**Register Name:** UHDMAX\_CONTROL, X in [1..6]  
**Access Type:** Read/Write  
**Reset Value:** 0x00000000

31	30	29	28	27	26	25	24
CH_BYTE_LENGTH							
rwu							
0	0	0	0	0	0	0	0
23	22	21	20	19	18	17	16
CH_BYTE_LENGTH							
rwu							
0	0	0	0	0	0	0	0
15	14	13	12	11	10	9	8
-	-	-	-	-	-	-	-

7	6	5	4	3	2	1	0
BURST_LOCK_EN	DESC_LD_IRQ_EN	EOBUFF_IRQ_EN	EOT_IRQ_EN	DMAEND_EN	BUFF_CLOSE_IN_EN	LD_NXT_CH_DESC_EN	CH_EN
rwu							
0	0	0	0	0	0	0	0

Same as "USB Device DMA Channel X Control Register (UDDMAX\_CONTROL)" on page 593.

(just replace the IN endpoint term by OUT endpoint, and vice-versa)

## 30.8.3.24 USB Host DMA Channel X Status Register (UHDMAX\_STATUS)

**Offset:** 0x071C + (X - 1) . 0x10  
**Register Name:** UHDMAX\_STATUS, X in [1..6]  
**Access Type:** Read/Write  
**Reset Value:** 0x00000000

31	30	29	28	27	26	25	24
CH_BYTE_CNT							
ru							
0	0	0	0	0	0	0	0
23	22	21	20	19	18	17	16
CH_BYTE_CNT							
ru							
0	0	0	0	0	0	0	0
15	14	13	12	11	10	9	8
-	-	-	-	-	-	-	-
7	6	5	4	3	2	1	0
-	DESC_LD_STA	EOCH_BUFF_STA	EOT_STA	-	-	CH_ACTIVE	CH_EN
	ru	ru	ru			rwu	rwu
	0	0	0			0	0

Same as "USB Device DMA Channel X Status Register (UDDMAX\_STATUS)" on page 595.

#### **30.8.4 USB Pipe/Endpoint X FIFO Data Register (USB\_FIFOX\_DATA)**

Note that this register can be accessed even if USBE = 0 or FRZCLK = 1. Disabling the USB controller (by clearing the USBE bit) does not reset the DPRAM.

## 31. Timer/Counter (TC)

Rev: 2.2.2.1

### 31.1 Features

- **Three 16-bit Timer Counter Channels**
- **A Wide Range of Functions Including:**
  - Frequency Measurement
  - Event Counting
  - Interval Measurement
  - Pulse Generation
  - Delay Timing
  - Pulse Width Modulation
  - Up/down Capabilities
- **Each Channel is User-configurable and Contains:**
  - Three External Clock Inputs
  - Five Internal Clock Inputs
  - Two Multi-purpose Input/Output Signals
- **Internal Interrupt Signal**
- **Two Global Registers that Act on All Three TC Channels**

### 31.2 Description

The Timer Counter (TC) includes three identical 16-bit Timer Counter channels.

Each channel can be independently programmed to perform a wide range of functions including frequency measurement, event counting, interval measurement, pulse generation, delay timing and pulse width modulation.

Each channel has three external clock inputs, five internal clock inputs and two multi-purpose input/output signals which can be configured by the user. Each channel drives an internal interrupt signal which can be programmed to generate processor interrupts.

The Timer Counter block has two global registers which act upon all three TC channels.

The Block Control Register allows the three channels to be started simultaneously with the same instruction.

The Block Mode Register defines the external clock inputs for each channel, allowing them to be chained.

### 31.3 Block Diagram

Figure 31-1. Timer Counter Block Diagram

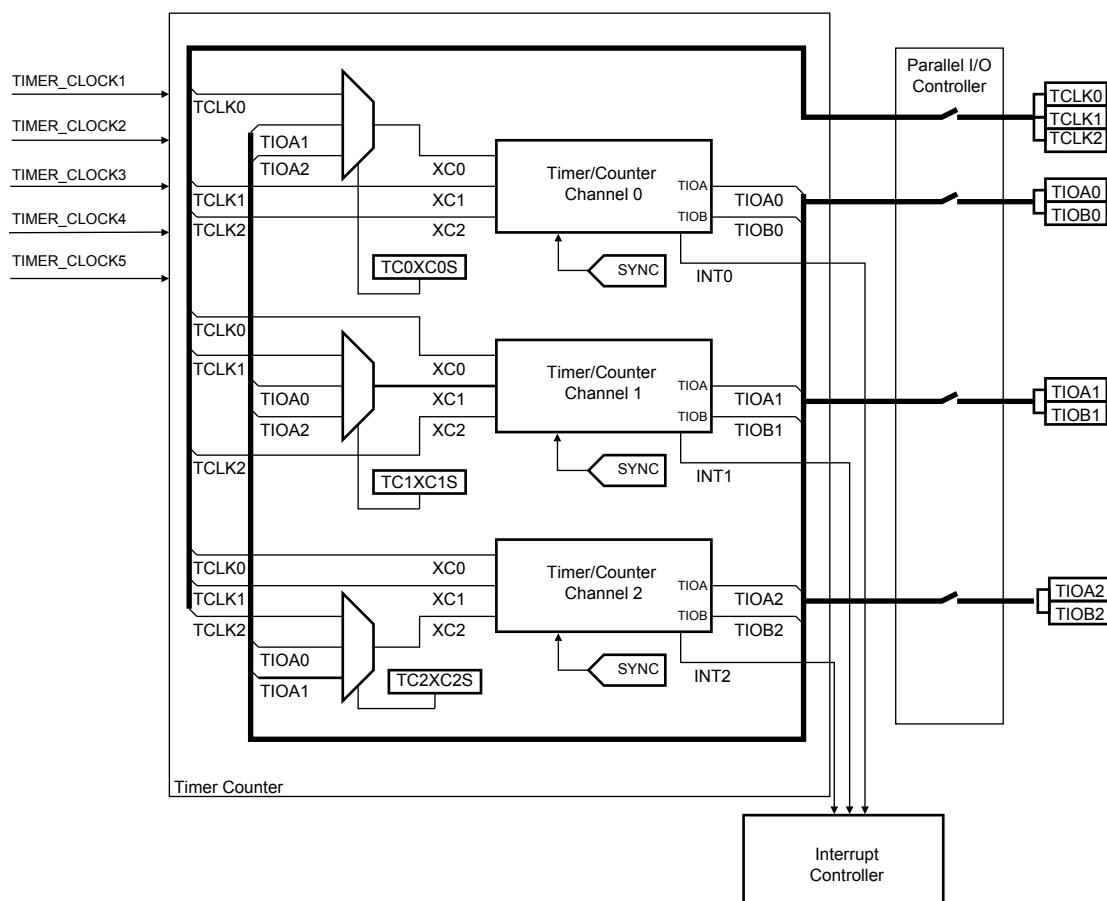

Table 31-1. Signal Name Description

Block/Channel	Signal Name	Description
Channel Signal	XC0, XC1, XC2	External Clock Inputs
	TIOA	Capture Mode: Timer Counter Input Waveform Mode: Timer Counter Output
	TIOB	Capture Mode: Timer Counter Input Waveform Mode: Timer Counter Input/Output
	INT	Interrupt Signal Output
	SYNC	Synchronization Input Signal



## 31.4 Pin Name List

**Table 31-2.** TC pin list

Pin Name	Description	Type
TCLK0-TCLK2	External Clock Input	Input
TIOA0-TIOA2	I/O Line A	I/O
TIOB0-TIOB2	I/O Line B	I/O

## 31.5 Product Dependencies

### 31.5.1 I/O Lines

The pins used for interfacing the compliant external devices may be multiplexed with PIO lines. The programmer must first program the PIO controllers to assign the TC pins to their peripheral functions.

### 31.5.2 Debug operation

The Timer Counter clocks are frozen during debug operation, unless the OCD system keeps peripherals running in debug operation.

### 31.5.3 Power Management

The Timer Counter clock is generated by the power manager. Before using the TC, the programmer must ensure that the TC clock is enabled in the power manager.

### 31.5.4 Interrupt

The TC has an interrupt line connected to the interrupt controller. Handling the TC interrupt requires programming the interrupt controller before configuring the TC.

## 31.6 Functional Description

### 31.6.1 TC Description

The three channels of the Timer Counter are independent and identical in operation. The registers for channel programming are listed in [Table 31-4 on page 654](#).

#### 31.6.1.1 16-bit Counter

Each channel is organized around a 16-bit counter. The value of the counter is incremented at each positive edge of the selected clock. When the counter has reached the value 0xFFFF and passes to 0x0000, an overflow occurs and the COVFS bit in SR (Status Register) is set.

The current value of the counter is accessible in real time by reading the Counter Value Register, CV. The counter can be reset by a trigger. In this case, the counter value passes to 0x0000 on the next valid edge of the selected clock.

#### 31.6.1.2 Clock Selection

At block level, input clock signals of each channel can either be connected to the external inputs TCLK0, TCLK1 or TCLK2, or be connected to the configurable I/O signals TIOA0, TIOA1 or TIOA2 for chaining by programming the BMR (Block Mode). See [Figure 31-2](#).

Each channel can independently select an internal or external clock source for its counter:

- Internal clock signals: TIMER\_CLOCK1, TIMER\_CLOCK2, TIMER\_CLOCK3, TIMER\_CLOCK4, TIMER\_CLOCK5. The Peripherals Chapter details the connection of these clock sources.
- External clock signals: XC0, XC1 or XC2. The Peripherals Chapter details the connection of these clock sources.

This selection is made by the TCCLKS bits in the TC Channel Mode Register .

The selected clock can be inverted with the CLKI bit in CMR. This allows counting on the opposite edges of the clock.

The burst function allows the clock to be validated when an external signal is high. The BURST parameter in the Mode Register defines this signal (none, XC0, XC1, XC2).

Note: In all cases, if an external clock is used, the duration of each of its levels must be longer than the master clock period. The external clock frequency must be at least 2.5 times lower than the master clock

**Figure 31-2.** Clock Selection

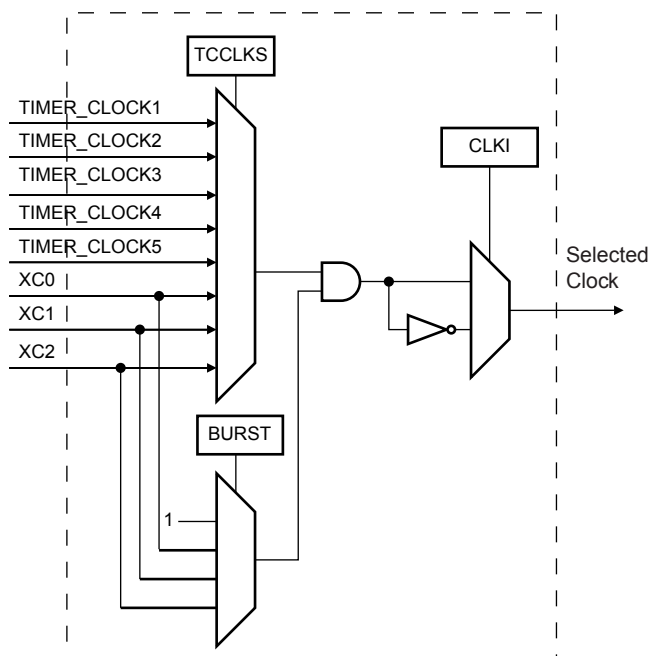

### 31.6.1.3 Clock Control

The clock of each counter can be controlled in two different ways: it can be enabled/disabled and started/stopped. See [Figure 31-3](#).

- The clock can be enabled or disabled by the user with the CLKEN and the CLKDIS commands in the Control Register. In Capture Mode it can be disabled by an RB load event if LDBDIS is set to 1 in CMR. In Waveform Mode, it can be disabled by an RC Compare event if CPCDIS is set to 1 in CMR. When disabled, the start or the stop actions have no effect: only a CLKEN command in the Control Register can re-enable the clock. When the clock is enabled, the CLKSTA bit is set in the Status Register.
- The clock can also be started or stopped: a trigger (software, synchro, external or compare) always starts the clock. The clock can be stopped by an RB load event in Capture Mode



If an external trigger is used, the duration of the pulses must be longer than the master clock period in order to be detected.

Regardless of the trigger used, it will be taken into account at the following active edge of the selected clock. This means that the counter value can be read differently from zero just after a trigger, especially when a low frequency signal is selected as the clock.

### 31.6.2 Capture Operating Mode

This mode is entered by clearing the WAVE parameter in CMR (Channel Mode Register).

Capture Mode allows the TC channel to perform measurements such as pulse timing, frequency, period, duty cycle and phase on TIOA and TIOB signals which are considered as inputs.

Figure 31-4 shows the configuration of the TC channel when programmed in Capture Mode.

#### 31.6.2.1 Capture Registers A and B

Registers A and B (RA and RB) are used as capture registers. This means that they can be loaded with the counter value when a programmable event occurs on the signal TIOA.

The LDRA parameter in CMR defines the TIOA edge for the loading of register A, and the LDRB parameter defines the TIOA edge for the loading of Register B.

RA is loaded only if it has not been loaded since the last trigger or if RB has been loaded since the last loading of RA.

RB is loaded only if RA has been loaded since the last trigger or the last loading of RB.

Loading RA or RB before the read of the last value loaded sets the Overrun Error Flag (LOVRS) in SR (Status Register). In this case, the old value is overwritten.

#### 31.6.2.2 Trigger Conditions

In addition to the SYNC signal, the software trigger and the RC compare trigger, an external trigger can be defined.

The ABETRG bit in CMR selects TIOA or TIOB input signal as an external trigger. The ETRGEDG parameter defines the edge (rising, falling or both) detected to generate an external trigger. If ETRGEDG = 0 (none), the external trigger is disabled.

Figure 31-4. Capture Mode

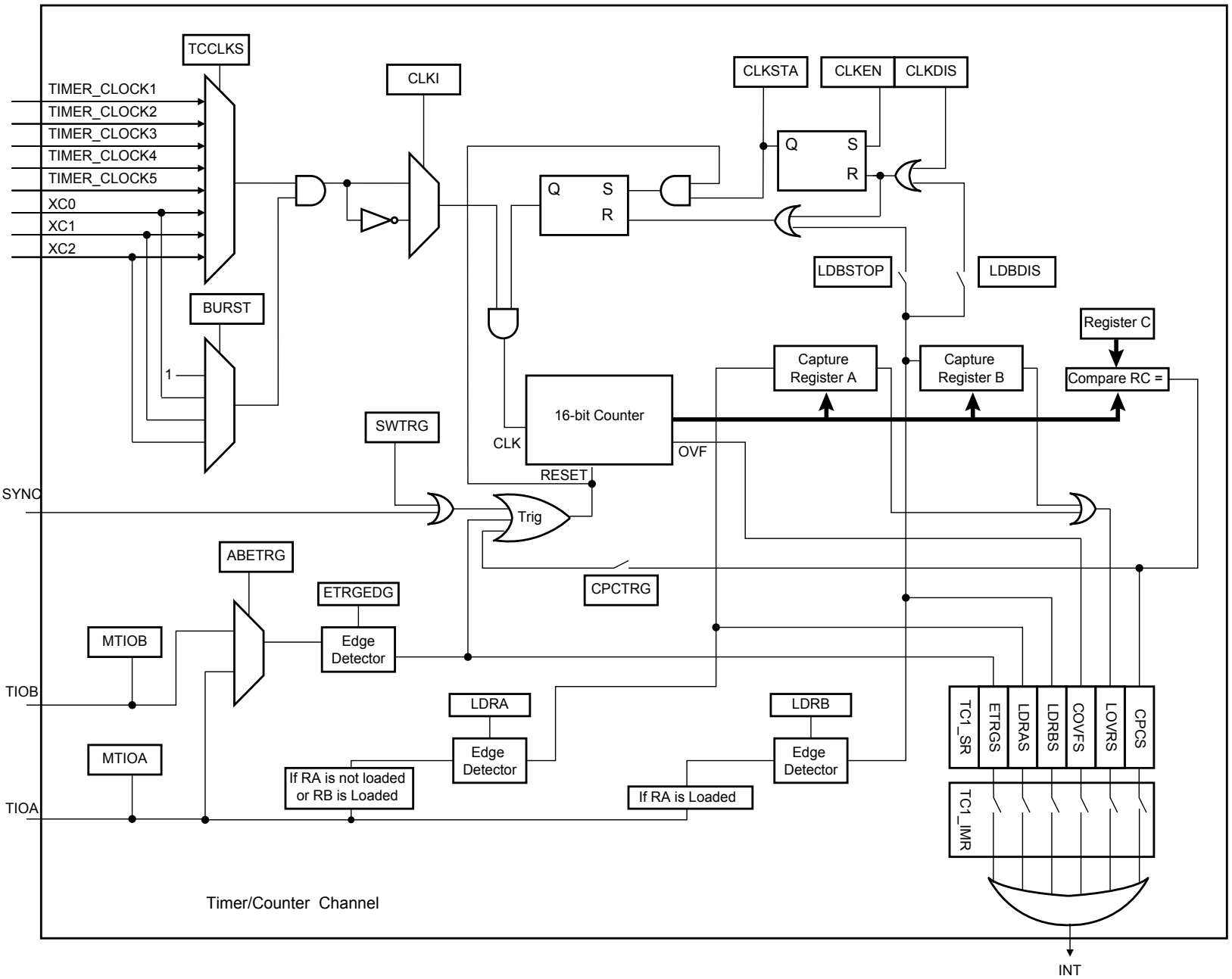

### 31.6.3 Waveform Operating Mode

Waveform operating mode is entered by setting the WAVE parameter in CMR (Channel Mode Register).

In Waveform Operating Mode the TC channel generates 1 or 2 PWM signals with the same frequency and independently programmable duty cycles, or generates different types of one-shot or repetitive pulses.

In this mode, TIOA is configured as an output and TIOB is defined as an output if it is not used as an external event (EEVT parameter in CMR).

Figure 31-5 shows the configuration of the TC channel when programmed in Waveform Operating Mode.

#### 31.6.3.1 Waveform Selection

Depending on the WAVSEL parameter in CMR (Channel Mode Register), the behavior of CV varies.

With any selection, RA, RB and RC can all be used as compare registers.

RA Compare is used to control the TIOA output, RB Compare is used to control the TIOB output (if correctly configured) and RC Compare is used to control TIOA and/or TIOB outputs.

Figure 31-5. Waveform Mode

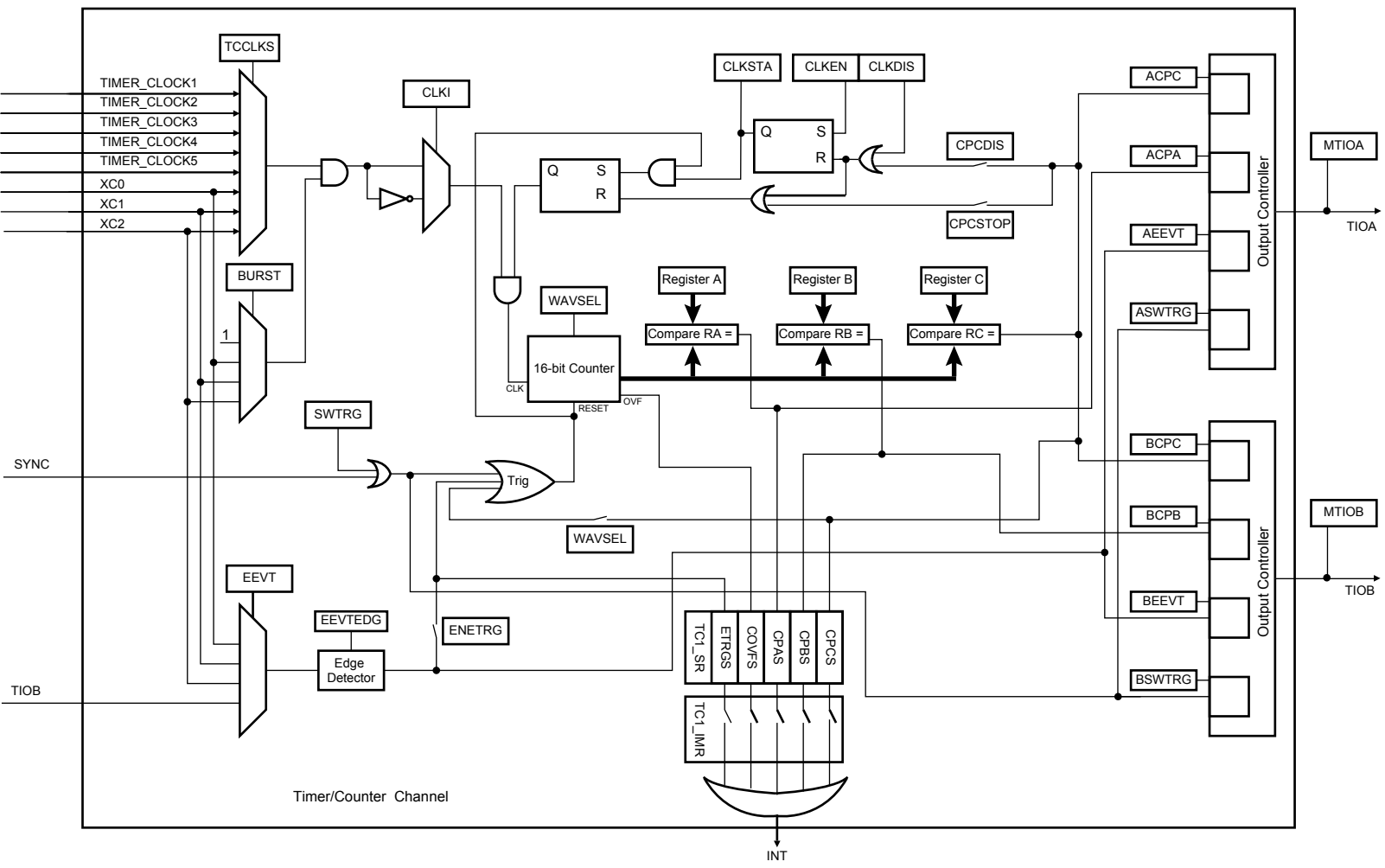

## 31.6.3.2 WAVSEL = 00

When WAVSEL = 00, the value of CV is incremented from 0 to 0xFFFF. Once 0xFFFF has been reached, the value of CV is reset. Incrementation of CV starts again and the cycle continues. See [Figure 31-6](#).

An external event trigger or a software trigger can reset the value of CV. It is important to note that the trigger may occur at any time. See [Figure 31-7](#).

RC Compare cannot be programmed to generate a trigger in this configuration. At the same time, RC Compare can stop the counter clock (CPCSTOP = 1 in CMR) and/or disable the counter clock (CPCDIS = 1 in CMR).

**Figure 31-6.** WAVSEL= 00 without trigger

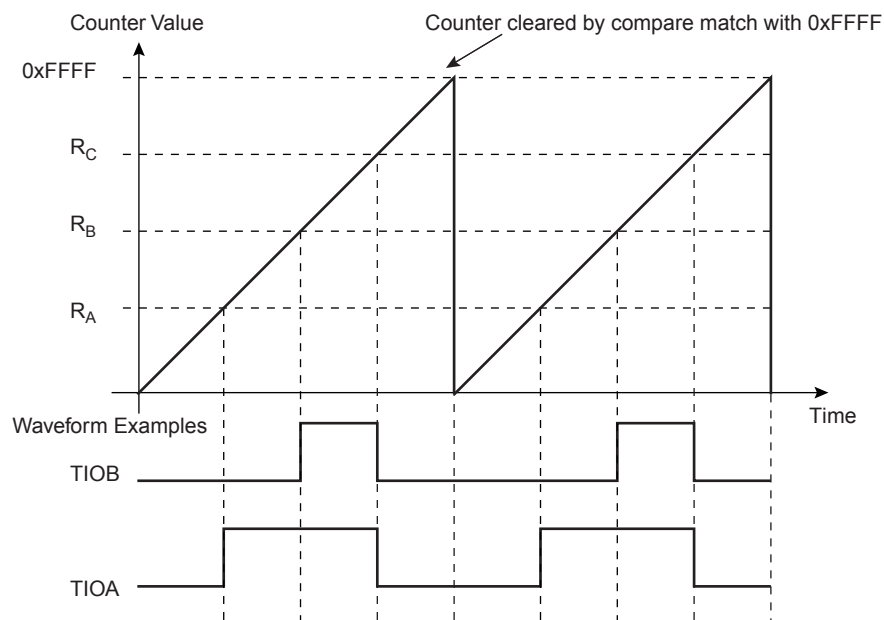



**Figure 31-7.** WAVSEL= 00 with trigger

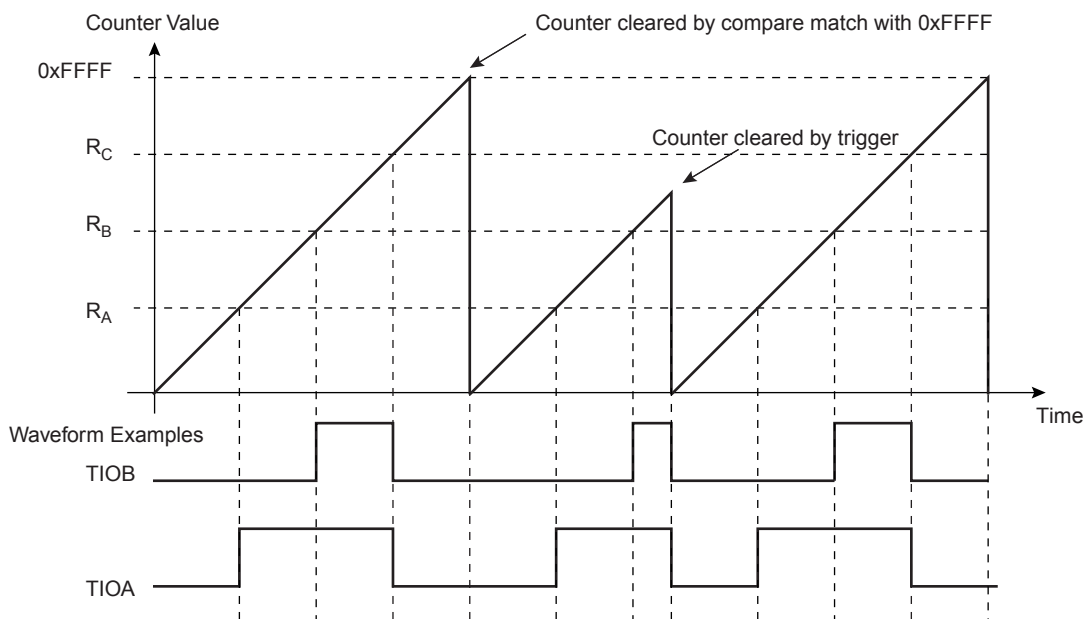

31.6.3.3 WAVSEL = 10

When WAVSEL = 10, the value of CV is incremented from 0 to the value of RC, then automatically reset on a RC Compare. Once the value of CV has been reset, it is then incremented and so on. See [Figure 31-8](#).

It is important to note that CV can be reset at any time by an external event or a software trigger if both are programmed correctly. See [Figure 31-9](#).

In addition, RC Compare can stop the counter clock (CPCSTOP = 1 in CMR) and/or disable the counter clock (CPCDIS = 1 in CMR).

**Figure 31-8.** WAVSEL = 10 Without Trigger

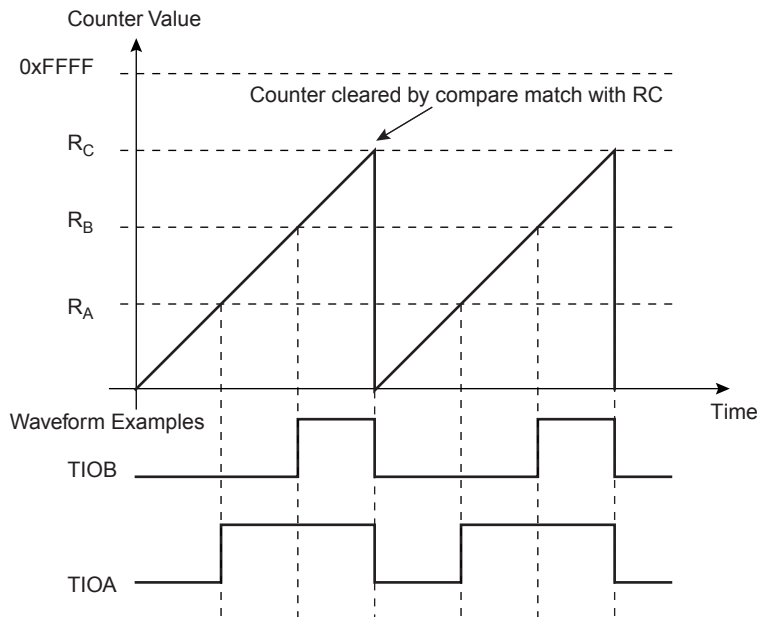

**Figure 31-9.** WAVSEL = 10 With Trigger

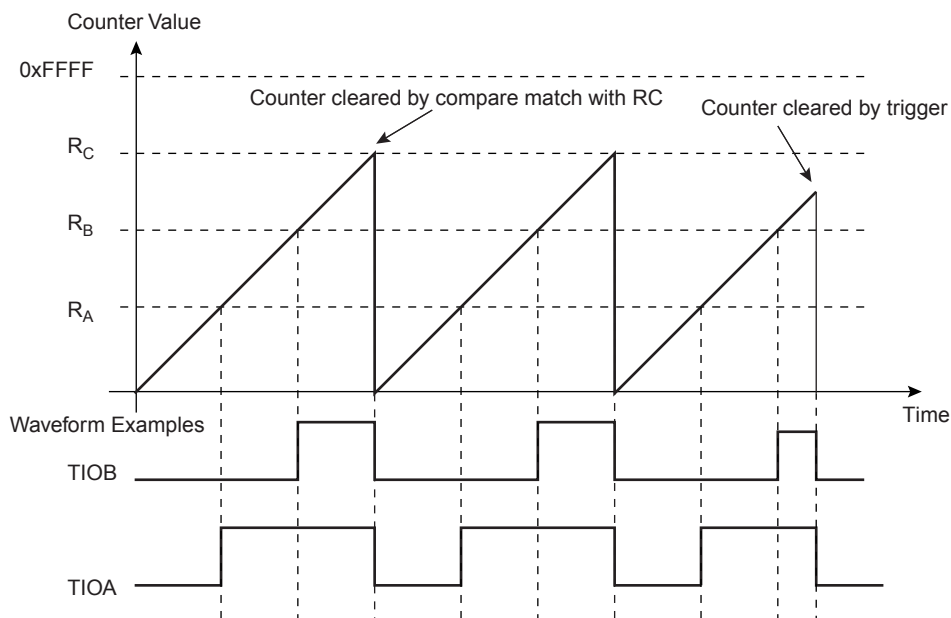

31.6.3.4 WAVSEL = 01

When WAVSEL = 01, the value of CV is incremented from 0 to 0xFFFF. Once 0xFFFF is reached, the value of CV is decremented to 0, then re-incremented to 0xFFFF and so on. See [Figure 31-10](#).

A trigger such as an external event or a software trigger can modify CV at any time. If a trigger occurs while CV is incrementing, CV then decrements. If a trigger is received while CV is decrementing, CV then increments. See [Figure 31-11](#).

RC Compare cannot be programmed to generate a trigger in this configuration.

At the same time, RC Compare can stop the counter clock (CPCSTOP = 1) and/or disable the counter clock (CPCDIS = 1).

**Figure 31-10. WAVSEL = 01 Without Trigger**

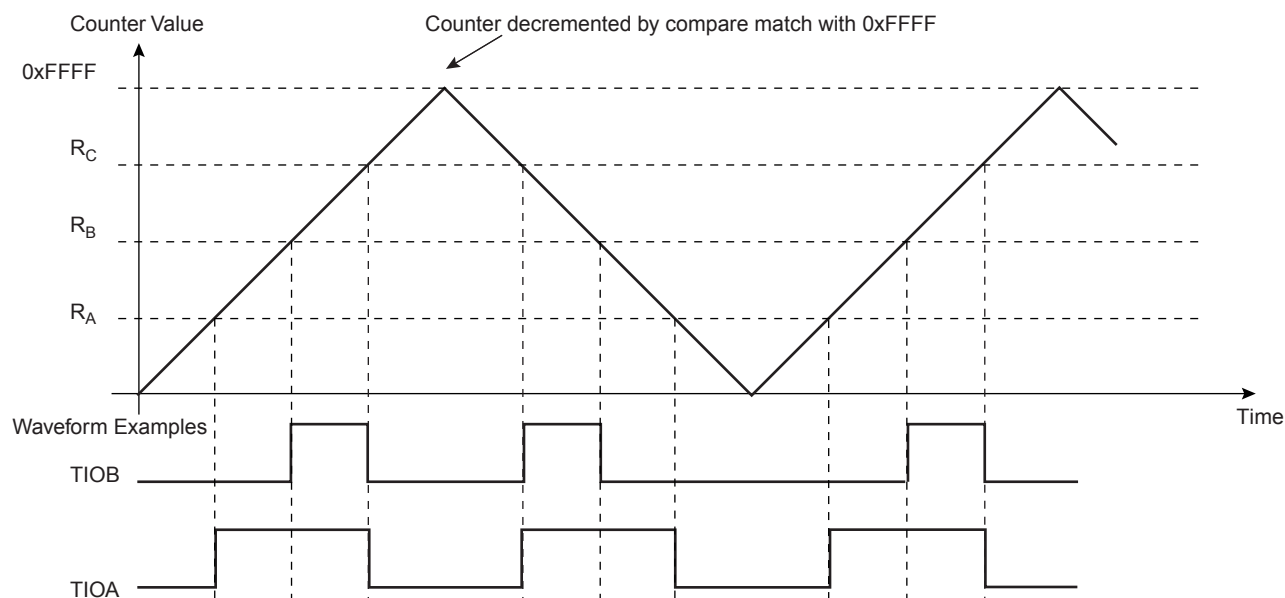

**Figure 31-11. WAVSEL = 01 With Trigger**

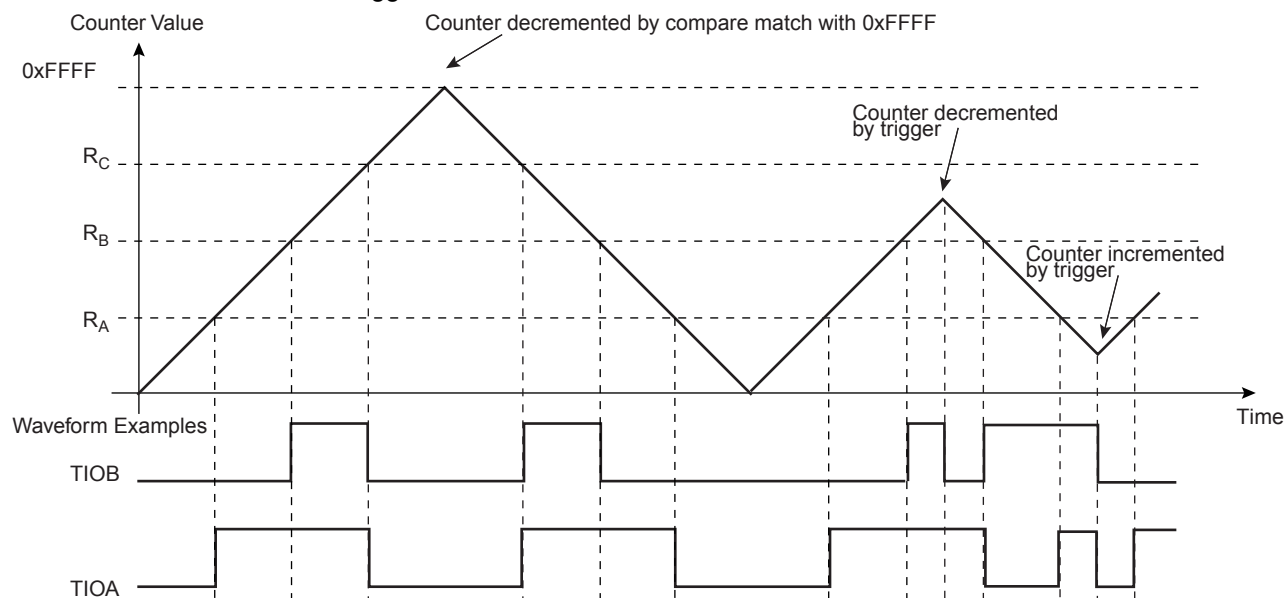

31.6.3.5 WAVSEL = 11

When WAVSEL = 11, the value of CV is incremented from 0 to RC. Once RC is reached, the value of CV is decremented to 0, then re-incremented to RC and so on. See [Figure 31-12](#).

A trigger such as an external event or a software trigger can modify CV at any time. If a trigger occurs while CV is incrementing, CV then decrements. If a trigger is received while CV is decrementing, CV then increments. See [Figure 31-13](#).

RC Compare can stop the counter clock (CPCSTOP = 1) and/or disable the counter clock (CPCDIS = 1).

**Figure 31-12. WAVSEL = 11 Without Trigger**

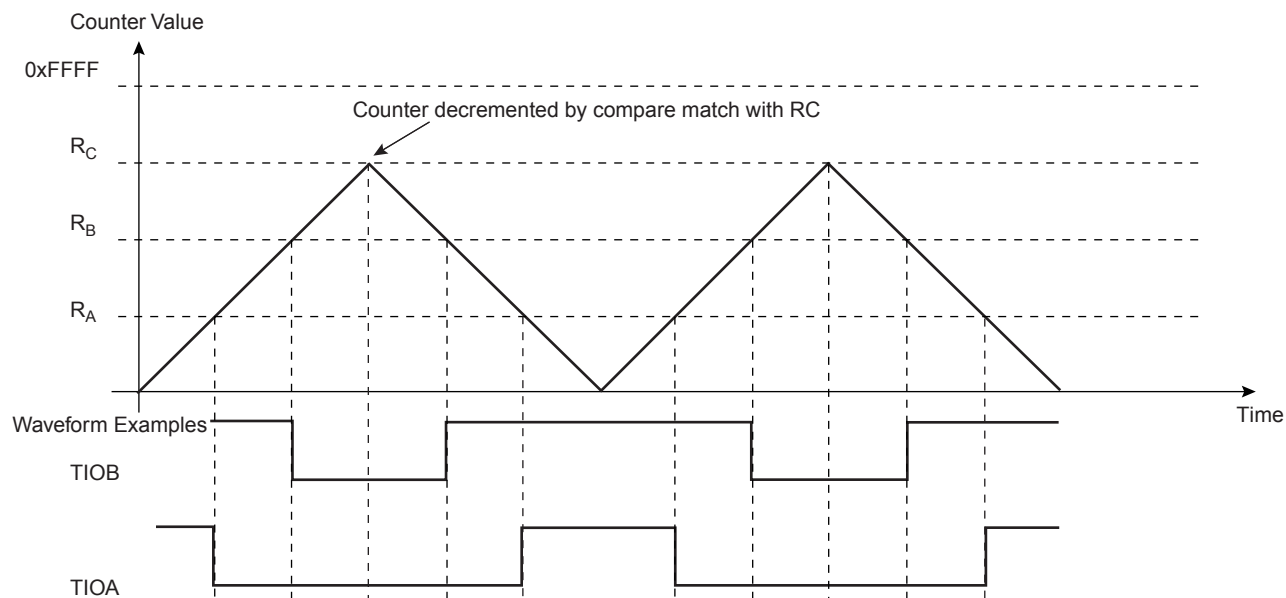

**Figure 31-13. WAVSEL = 11 With Trigger**

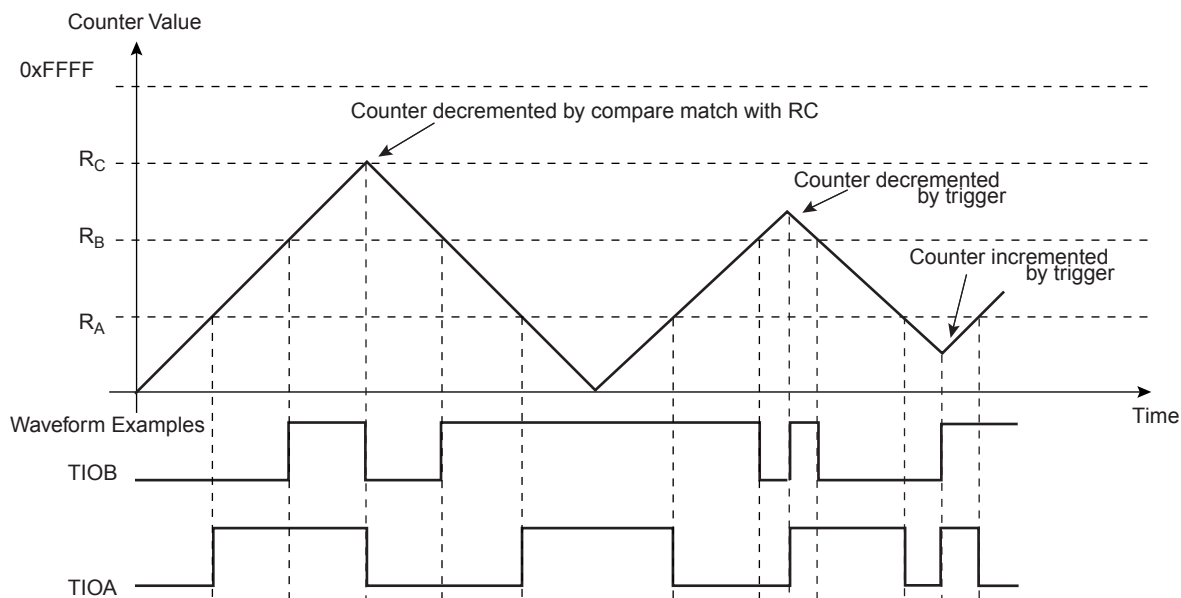

**31.6.3.6 External Event/Trigger Conditions**

An external event can be programmed to be detected on one of the clock sources (XC0, XC1, XC2) or TIOB. The external event selected can then be used as a trigger.

The EEVT parameter in CMR selects the external trigger. The EEVTEG parameter defines the trigger edge for each of the possible external triggers (rising, falling or both). If EEVTEG is cleared (none), no external event is defined.

If TIOB is defined as an external event signal (EEVT = 0), TIOB is no longer used as an output and the compare register B is not used to generate waveforms and subsequently no IRQs. In this case the TC channel can only generate a waveform on TIOA.

When an external event is defined, it can be used as a trigger by setting bit ENETRIG in CMR.

As in Capture Mode, the SYNC signal and the software trigger are also available as triggers. RC Compare can also be used as a trigger depending on the parameter WAVSEL.

#### 31.6.3.7 *Output Controller*

The output controller defines the output level changes on TIOA and TIOB following an event. TIOB control is used only if TIOB is defined as output (not as an external event).

The following events control TIOA and TIOB: software trigger, external event and RC compare. RA compare controls TIOA and RB compare controls TIOB. Each of these events can be programmed to set, clear or toggle the output as defined in the corresponding parameter in CMR.

## 31.7 Timer Counter (TC) User Interface

**Table 31-3.** TC Global Memory Map

Offset	Channel/Register	Name	Access	Reset Value
0x00	TC Channel 0		See <a href="#">Table 31-4</a>	
0x40	TC Channel 1		See <a href="#">Table 31-4</a>	
0x80	TC Channel 2		See <a href="#">Table 31-4</a>	
0xC0	TC Block Control Register	BCR	Write-only	–
0xC4	TC Block Mode Register	BMR	Read/Write	0

BCR (Block Control Register) and BMR (Block Mode Register) control the whole TC block. TC channels are controlled by the registers listed in [Table 31-4](#). The offset of each of the channel registers in [Table 31-4](#) is in relation to the offset of the corresponding channel as mentioned in [Table 31-4](#).

**Table 31-4.** TC Channel Memory Map

Offset	Register	Name	Access	Reset Value
0x00	Channel Control Register	CCR	Write-only	–
0x04	Channel Mode Register	CMR	Read/Write	0
0x08	Reserved			–
0x0C	Reserved			–
0x10	Counter Value	CV	Read-only	0
0x14	Register A	RA	Read/Write <sup>(1)</sup>	0
0x18	Register B	RB	Read/Write <sup>(1)</sup>	0
0x1C	Register C	RC	Read/Write	0
0x20	Status Register	SR	Read-only	0
0x24	Interrupt Enable Register	IER	Write-only	–
0x28	Interrupt Disable Register	IDR	Write-only	–
0x2C	Interrupt Mask Register	IMR	Read-only	0

Notes: 1. Read-only if WAVE = 0

## 31.7.1 TC Block Control Register

**Register Name:** BCR

**Access Type:** Write-only

31	30	29	28	27	26	25	24
-	-	-	-	-	-	-	-
23	22	21	20	19	18	17	16
-	-	-	-	-	-	-	-
15	14	13	12	11	10	9	8
-	-	-	-	-	-	-	-
7	6	5	4	3	2	1	0
-	-	-	-	-	-	-	SYNC

- **SYNC: Synchro Command**

0 = No effect.

1 = Asserts the SYNC signal which generates a software trigger simultaneously for each of the channels.

## 31.7.2 TC Block Mode Register

**Register Name:** BMR

**Access Type:** Read/Write

31	30	29	28	27	26	25	24
–	–	–	–	–	–	–	–
23	22	21	20	19	18	17	16
–	–	–	–	–	–	–	–
15	14	13	12	11	10	9	8
–	–	–	–	–	–	–	–
7	6	5	4	3	2	1	0
–	–	TC2XC2S		TC1XC1S		TC0XC0S	

- **TC0XC0S: External Clock Signal 0 Selection**

TC0XC0S		Signal Connected to XC0
0	0	TCLK0
0	1	none
1	0	TIOA1
1	1	TIOA2

- **TC1XC1S: External Clock Signal 1 Selection**

TC1XC1S		Signal Connected to XC1
0	0	TCLK1
0	1	none
1	0	TIOA0
1	1	TIOA2

- **TC2XC2S: External Clock Signal 2 Selection**

TC2XC2S		Signal Connected to XC2
0	0	TCLK2
0	1	none
1	0	TIOA0
1	1	TIOA1



## 31.7.3 TC Channel Control Register

**Register Name:** CCR

**Access Type:** Write-only

31	30	29	28	27	26	25	24
–	–	–	–	–	–	–	–
23	22	21	20	19	18	17	16
–	–	–	–	–	–	–	–
15	14	13	12	11	10	9	8
–	–	–	–	–	–	–	–
7	6	5	4	3	2	1	0
–	–	–	–	–	SWTRG	CLKDIS	CLKEN

- **CLKEN: Counter Clock Enable Command**

0 = No effect.

1 = Enables the clock if CLKDIS is not 1.

- **CLKDIS: Counter Clock Disable Command**

0 = No effect.

1 = Disables the clock.

- **SWTRG: Software Trigger Command**

0 = No effect.

1 = A software trigger is performed: the counter is reset and the clock is started.

## 31.7.4 TC Channel Mode Register: Capture Mode

**Register Name:** CMR

**Access Type:** Read/Write

31	30	29	28	27	26	25	24
–	–	–	–	–	–	–	–
23	22	21	20	19	18	17	16
–	–	–	–	LDRB		LDRA	
15	14	13	12	11	10	9	8
WAVE = 0	CPCTRG	–	–	–	ABETRG	ETRGEDG	
7	6	5	4	3	2	1	0
LDBDIS	LDBSTOP	BURST		CLKI	TCCLKS		

- **TCCLKS: Clock Selection**

TCCLKS			Clock Selected
0	0	0	TIMER_CLOCK1
0	0	1	TIMER_CLOCK2
0	1	0	TIMER_CLOCK3
0	1	1	TIMER_CLOCK4
1	0	0	TIMER_CLOCK5
1	0	1	XC0
1	1	0	XC1
1	1	1	XC2

- **CLKI: Clock Invert**

0 = Counter is incremented on rising edge of the clock.

1 = Counter is incremented on falling edge of the clock.

- **BURST: Burst Signal Selection**

BURST		
0	0	The clock is not gated by an external signal.
0	1	XC0 is ANDed with the selected clock.
1	0	XC1 is ANDed with the selected clock.
1	1	XC2 is ANDed with the selected clock.

- **LDBSTOP: Counter Clock Stopped with RB Loading**

0 = Counter clock is not stopped when RB loading occurs.

1 = Counter clock is stopped when RB loading occurs.

- **LDBDIS: Counter Clock Disable with RB Loading**

0 = Counter clock is not disabled when RB loading occurs.

1 = Counter clock is disabled when RB loading occurs.

- **ETRGEDG: External Trigger Edge Selection**

ETRGEDG		Edge
0	0	none
0	1	rising edge
1	0	falling edge
1	1	each edge

- **ABETRG: TIOA or TIOB External Trigger Selection**

0 = TIOB is used as an external trigger.

1 = TIOA is used as an external trigger.

- **CPCTRG: RC Compare Trigger Enable**

0 = RC Compare has no effect on the counter and its clock.

1 = RC Compare resets the counter and starts the counter clock.

- **WAVE**

0 = Capture Mode is enabled.

1 = Capture Mode is disabled (Waveform Mode is enabled).

- **LDRA: RA Loading Selection**

LDRA		Edge
0	0	none
0	1	rising edge of TIOA
1	0	falling edge of TIOA
1	1	each edge of TIOA

- **LDRB: RB Loading Selection**

LDRB		Edge
0	0	none
0	1	rising edge of TIOA
1	0	falling edge of TIOA
1	1	each edge of TIOA

## 31.7.5 TC Channel Mode Register: Waveform Mode

**Register Name:** CMR

**Access Type:** Read/Write

31	30	29	28	27	26	25	24
BSWTRG		BEEVT		BCPC		BCPB	
23	22	21	20	19	18	17	16
ASWTRG		AEEVT		ACPC		ACPA	
15	14	13	12	11	10	9	8
WAVE = 1	WAVSEL		ENETRГ	EEVT		EEVTEDG	
7	6	5	4	3	2	1	0
CPCDIS	CPCSTOP	BURST		CLKI	TCCLKS		

- **TCCLKS: Clock Selection**

TCCLKS			Clock Selected
0	0	0	TIMER_CLOCK1
0	0	1	TIMER_CLOCK2
0	1	0	TIMER_CLOCK3
0	1	1	TIMER_CLOCK4
1	0	0	TIMER_CLOCK5
1	0	1	XC0
1	1	0	XC1
1	1	1	XC2

- **CLKI: Clock Invert**

0 = Counter is incremented on rising edge of the clock.

1 = Counter is incremented on falling edge of the clock.

- **BURST: Burst Signal Selection**

BURST		
0	0	The clock is not gated by an external signal.
0	1	XC0 is ANDed with the selected clock.
1	0	XC1 is ANDed with the selected clock.
1	1	XC2 is ANDed with the selected clock.

- **CPCSTOP: Counter Clock Stopped with RC Compare**

0 = Counter clock is not stopped when counter reaches RC.

1 = Counter clock is stopped when counter reaches RC.

- **CPCDIS: Counter Clock Disable with RC Compare**

0 = Counter clock is not disabled when counter reaches RC.

1 = Counter clock is disabled when counter reaches RC.

- **EEVTEDG: External Event Edge Selection**

EEVTEDG		Edge
0	0	none
0	1	rising edge
1	0	falling edge
1	1	each edge

- **EEVT: External Event Selection**

EEVT		Signal selected as external event	TIOB Direction
0	0	TIOB	input <sup>(1)</sup>
0	1	XC0	output
1	0	XC1	output
1	1	XC2	output

Note: 1. If TIOB is chosen as the external event signal, it is configured as an input and no longer generates waveforms and subsequently no IRQs.

- **ENETRГ: External Event Trigger Enable**

0 = The external event has no effect on the counter and its clock. In this case, the selected external event only controls the TIOA output.

1 = The external event resets the counter and starts the counter clock.

- **WAVSEL: Waveform Selection**

WAVSEL		Effect
0	0	UP mode without automatic trigger on RC Compare
1	0	UP mode with automatic trigger on RC Compare
0	1	UPDOWN mode without automatic trigger on RC Compare
1	1	UPDOWN mode with automatic trigger on RC Compare

- **WAVE = 1**

0 = Waveform Mode is disabled (Capture Mode is enabled).

1 = Waveform Mode is enabled.

- **ACPA: RA Compare Effect on TIOA**

ACPA		Effect
0	0	none
0	1	set
1	0	clear
1	1	toggle

- **ACPC: RC Compare Effect on TIOA**

ACPC		Effect
0	0	none
0	1	set
1	0	clear
1	1	toggle

- **AEEVT: External Event Effect on TIOA**

AEEVT		Effect
0	0	none
0	1	set
1	0	clear
1	1	toggle

- **ASWTRG: Software Trigger Effect on TIOA**

ASWTRG		Effect
0	0	none
0	1	set
1	0	clear
1	1	toggle

- **BCPB: RB Compare Effect on TIOB**

BCPB		Effect
0	0	none

BCPB		Effect
0	1	set
1	0	clear
1	1	toggle

- **BCPC: RC Compare Effect on TIOB**

BCPC		Effect
0	0	none
0	1	set
1	0	clear
1	1	toggle

- **BEEVT: External Event Effect on TIOB**

BEEVT		Effect
0	0	none
0	1	set
1	0	clear
1	1	toggle

- **BSWTRG: Software Trigger Effect on TIOB**

BSWTRG		Effect
0	0	none
0	1	set
1	0	clear
1	1	toggle

31.7.6 TC Counter Value Register

Register Name: CV

Access Type: Read-only

31	30	29	28	27	26	25	24
–	–	–	–	–	–	–	–
23	22	21	20	19	18	17	16
–	–	–	–	–	–	–	–
15	14	13	12	11	10	9	8
CV							
7	6	5	4	3	2	1	0
CV							

- **CV: Counter Value**

CV contains the counter value in real time.



## 31.7.7 TC Register A

**Register Name:** RA

**Access Type:** Read-only if WAVE = 0, Read/Write if WAVE = 1

31	30	29	28	27	26	25	24
–	–	–	–	–	–	–	–
23	22	21	20	19	18	17	16
–	–	–	–	–	–	–	–
15	14	13	12	11	10	9	8
RA							
7	6	5	4	3	2	1	0
RA							

- **RA: Register A**

RA contains the Register A value in real time.

## 31.7.8 TC Register B

**Register Name:** RB

**Access Type:** Read-only if WAVE = 0, Read/Write if WAVE = 1

31	30	29	28	27	26	25	24
–	–	–	–	–	–	–	–
23	22	21	20	19	18	17	16
–	–	–	–	–	–	–	–
15	14	13	12	11	10	9	8
RB							
7	6	5	4	3	2	1	0
RB							

- **RB: Register B**

RB contains the Register B value in real time.

## 31.7.9 TC Register C

**Register Name:** RC

**Access Type:** Read/Write

31	30	29	28	27	26	25	24
–	–	–	–	–	–	–	–
23	22	21	20	19	18	17	16
–	–	–	–	–	–	–	–
15	14	13	12	11	10	9	8
RC							
7	6	5	4	3	2	1	0
RC							

- **RC: Register C**

RC contains the Register C value in real time.

## 31.7.10 TC Status Register

**Register Name:** SR  
**Access Type:** Read-only

31	30	29	28	27	26	25	24
–	–	–	–	–	–	–	–
23	22	21	20	19	18	17	16
–	–	–	–	–	MTIOB	MTIOA	CLKSTA
15	14	13	12	11	10	9	8
–	–	–	–	–	–	–	–
7	6	5	4	3	2	1	0
ETRGS	LDRBS	LDRAS	CPCS	CPBS	CPAS	LOVRS	COVFS

Note: Reading the Status Register will also clear the interrupt flag for the corresponding interrupts.

- **COVFS: Counter Overflow Status**

0 = No counter overflow has occurred since the last read of the Status Register.

1 = A counter overflow has occurred since the last read of the Status Register.

- **LOVRS: Load Overrun Status**

0 = Load overrun has not occurred since the last read of the Status Register or WAVE = 1.

1 = RA or RB have been loaded at least twice without any read of the corresponding register since the last read of the Status Register, if WAVE = 0.

- **CPAS: RA Compare Status**

0 = RA Compare has not occurred since the last read of the Status Register or WAVE = 0.

1 = RA Compare has occurred since the last read of the Status Register, if WAVE = 1.

- **CPBS: RB Compare Status**

0 = RB Compare has not occurred since the last read of the Status Register or WAVE = 0.

1 = RB Compare has occurred since the last read of the Status Register, if WAVE = 1.

- **CPCS: RC Compare Status**

0 = RC Compare has not occurred since the last read of the Status Register.

1 = RC Compare has occurred since the last read of the Status Register.

- **LDRAS: RA Loading Status**

0 = RA Load has not occurred since the last read of the Status Register or WAVE = 1.

1 = RA Load has occurred since the last read of the Status Register, if WAVE = 0.

- **LDRBS: RB Loading Status**

0 = RB Load has not occurred since the last read of the Status Register or WAVE = 1.

1 = RB Load has occurred since the last read of the Status Register, if WAVE = 0.

- **ETRGS: External Trigger Status**

0 = External trigger has not occurred since the last read of the Status Register.

1 = External trigger has occurred since the last read of the Status Register.



- **CLKSTA: Clock Enabling Status**

0 = Clock is disabled.

1 = Clock is enabled.

- **MTIOA: TIOA Mirror**

0 = TIOA is low. If WAVE = 0, this means that TIOA pin is low. If WAVE = 1, this means that TIOA is driven low.

1 = TIOA is high. If WAVE = 0, this means that TIOA pin is high. If WAVE = 1, this means that TIOA is driven high.

- **MTIOB: TIOB Mirror**

0 = TIOB is low. If WAVE = 0, this means that TIOB pin is low. If WAVE = 1, this means that TIOB is driven low.

1 = TIOB is high. If WAVE = 0, this means that TIOB pin is high. If WAVE = 1, this means that TIOB is driven high.

## 31.7.11 TC Interrupt Enable Register

**Register Name:** IER

**Access Type:** Write-only

31	30	29	28	27	26	25	24
–	–	–	–	–	–	–	–
23	22	21	20	19	18	17	16
–	–	–	–	–	–	–	–
15	14	13	12	11	10	9	8
–	–	–	–	–	–	–	–
7	6	5	4	3	2	1	0
ETRGS	LDRBS	LDRAS	CPCS	CPBS	CPAS	LOVRS	COVFS

Note: Reading the Status Register will also clear the interrupt flag for the corresponding interrupts.

- **COVFS: Counter Overflow**

0 = No effect.

1 = Enables the Counter Overflow Interrupt.

- **LOVRS: Load Overrun**

0 = No effect.

1 = Enables the Load Overrun Interrupt.

- **CPAS: RA Compare**

0 = No effect.

1 = Enables the RA Compare Interrupt.

- **CPBS: RB Compare**

0 = No effect.

1 = Enables the RB Compare Interrupt.

- **CPCS: RC Compare**

0 = No effect.

1 = Enables the RC Compare Interrupt.

- **LDRAS: RA Loading**

0 = No effect.

1 = Enables the RA Load Interrupt.

- **LDRBS: RB Loading**

0 = No effect.

1 = Enables the RB Load Interrupt.

- **ETRGS: External Trigger**

0 = No effect.

1 = Enables the External Trigger Interrupt.

## 31.7.12 TC Interrupt Disable Register

**Register Name:** IDR

**Access Type:** Write-only

31	30	29	28	27	26	25	24
–	–	–	–	–	–	–	–
23	22	21	20	19	18	17	16
–	–	–	–	–	–	–	–
15	14	13	12	11	10	9	8
–	–	–	–	–	–	–	–
7	6	5	4	3	2	1	0
ETRGS	LDRBS	LDRAS	CPCS	CPBS	CPAS	LOVRS	COVFS

Note: Reading the Status Register will also clear the interrupt flag for the corresponding interrupts.

- **COVFS: Counter Overflow**

0 = No effect.

1 = Disables the Counter Overflow Interrupt.

- **LOVRS: Load Overrun**

0 = No effect.

1 = Disables the Load Overrun Interrupt (if WAVE = 0).

- **CPAS: RA Compare**

0 = No effect.

1 = Disables the RA Compare Interrupt (if WAVE = 1).

- **CPBS: RB Compare**

0 = No effect.

1 = Disables the RB Compare Interrupt (if WAVE = 1).

- **CPCS: RC Compare**

0 = No effect.

1 = Disables the RC Compare Interrupt.

- **LDRAS: RA Loading**

0 = No effect.

1 = Disables the RA Load Interrupt (if WAVE = 0).

- **LDRBS: RB Loading**

0 = No effect.

1 = Disables the RB Load Interrupt (if WAVE = 0).

- **ETRGS: External Trigger**

0 = No effect.

1 = Disables the External Trigger Interrupt.

## 31.7.13 TC Interrupt Mask Register

**Register Name:** IMR

**Access Type:** Read-only

31	30	29	28	27	26	25	24
–	–	–	–	–	–	–	–
23	22	21	20	19	18	17	16
–	–	–	–	–	–	–	–
15	14	13	12	11	10	9	8
–	–	–	–	–	–	–	–
7	6	5	4	3	2	1	0
ETRGS	LDRBS	LDRAS	CPCS	CPBS	CPAS	LOVRS	COVFS

Note: Reading the Status Register will also clear the interrupt flag for the corresponding interrupts.

- **COVFS: Counter Overflow**

0 = The Counter Overflow Interrupt is disabled.

1 = The Counter Overflow Interrupt is enabled.

- **LOVRS: Load Overrun**

0 = The Load Overrun Interrupt is disabled.

1 = The Load Overrun Interrupt is enabled.

- **CPAS: RA Compare**

0 = The RA Compare Interrupt is disabled.

1 = The RA Compare Interrupt is enabled.

- **CPBS: RB Compare**

0 = The RB Compare Interrupt is disabled.

1 = The RB Compare Interrupt is enabled.

- **CPCS: RC Compare**

0 = The RC Compare Interrupt is disabled.

1 = The RC Compare Interrupt is enabled.

- **LDRAS: RA Loading**

0 = The Load RA Interrupt is disabled.

1 = The Load RA Interrupt is enabled.

- **LDRBS: RB Loading**

0 = The Load RB Interrupt is disabled.

1 = The Load RB Interrupt is enabled.

- **ETRGS: External Trigger**

0 = The External Trigger Interrupt is disabled.

1 = The External Trigger Interrupt is enabled.



## 32. Pulse Width Modulation Controller (PWM)

Rev: 1.3.0.1

### 32.1 Features

- 7 Channels
- One 20-bit Counter Per Channel
- Common Clock Generator Providing Thirteen Different Clocks
  - A Modulo n Counter Providing Eleven Clocks
  - Two Independent Linear Dividers Working on Modulo n Counter Outputs
- Independent Channels
  - Independent Enable Disable Command for Each Channel
  - Independent Clock Selection for Each Channel
  - Independent Period and Duty Cycle for Each Channel
  - Double Buffering of Period or Duty Cycle for Each Channel
  - Programmable Selection of The Output Waveform Polarity for Each Channel
  - Programmable Center or Left Aligned Output Waveform for Each Channel

### 32.2 Description

The PWM macrocell controls several channels independently. Each channel controls one square output waveform. Characteristics of the output waveform such as period, duty-cycle and polarity are configurable through the user interface. Each channel selects and uses one of the clocks provided by the clock generator. The clock generator provides several clocks resulting from the division of the PWM macrocell master clock.

All PWM macrocell accesses are made through registers mapped on the peripheral bus.

Channels can be synchronized, to generate non overlapped waveforms. All channels integrate a double buffering system in order to prevent an unexpected output waveform while modifying the period or the duty-cycle.

### 32.3 Block Diagram

Figure 32-1. Pulse Width Modulation Controller Block Diagram

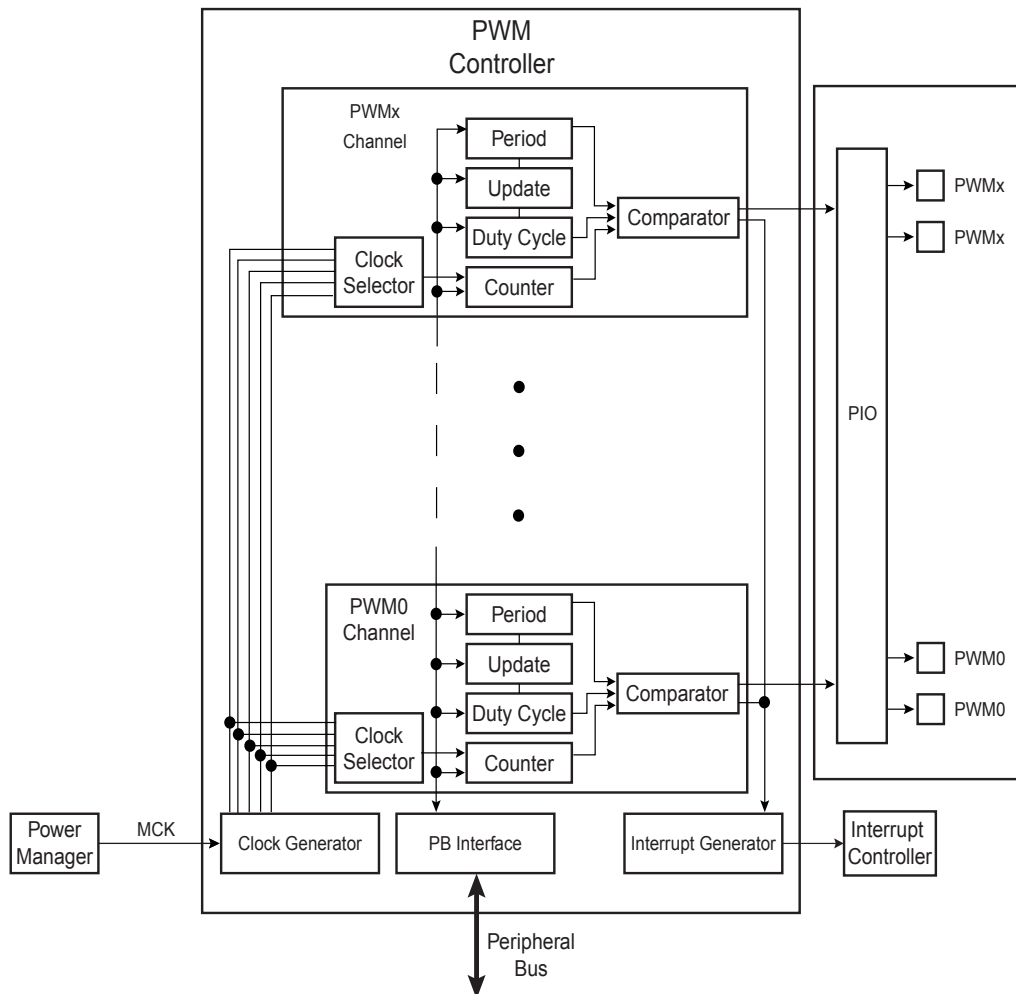

### 32.4 I/O Lines Description

Each channel outputs one waveform on one external I/O line.

Table 32-1. I/O Line Description

Name	Description	Type
PWMx	PWM Waveform Output for channel x	Output

## 32.5 Product Dependencies

### 32.5.1 I/O Lines

The pins used for interfacing the PWM may be multiplexed with PIO lines. The programmer must first program the PIO controller to assign the desired PWM pins to their peripheral function. If I/O lines of the PWM are not used by the application, they can be used for other purposes by the PIO controller.

Not all PWM outputs may be enabled. If an application requires only four channels, then only four PIO lines will be assigned to PWM outputs.

### 32.5.2 Debug operation

The PWM clock is running during debug operation.

### 32.5.3 Power Management

The PWM clock is generated by the Power Manager. Before using the PWM, the programmer must ensure that the PWM clock is enabled in the Power Manager. However, if the application does not require PWM operations, the PWM clock can be stopped when not needed and be restarted later. In this case, the PWM will resume its operations where it left off.

In the PWM description, Master Clock (MCK) is the clock of the peripheral bus to which the PWM is connected.

### 32.5.4 Interrupt Sources

The PWM interrupt line is connected to the interrupt controller. Using the PWM interrupt requires the interrupt controller to be programmed first.

## 32.6 Functional Description

The PWM macrocell is primarily composed of a clock generator module and 7 channels.

- Clocked by the system clock, MCK, the clock generator module provides 13 clocks.
- Each channel can independently choose one of the clock generator outputs.
- Each channel generates an output waveform with attributes that can be defined independently for each channel through the user interface registers.

### 32.6.1 PWM Clock Generator

**Figure 32-2.** Functional View of the Clock Generator Block Diagram

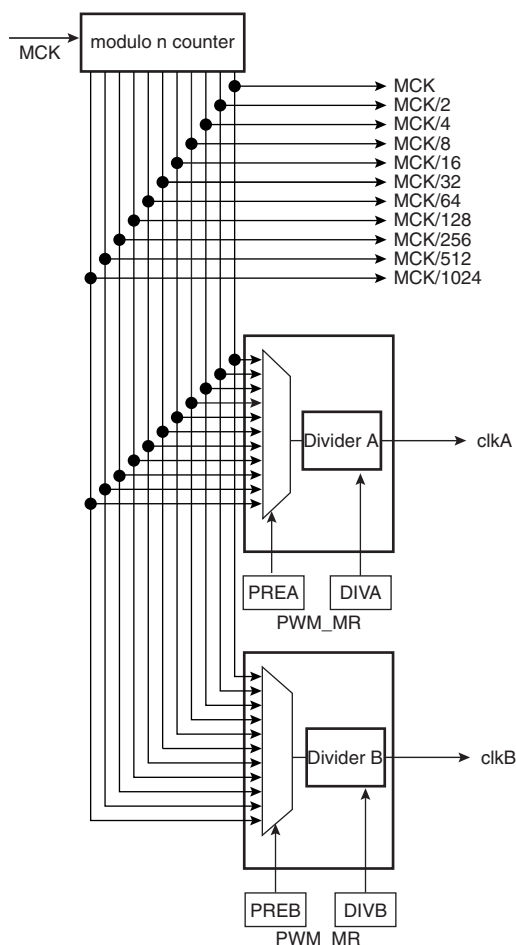

**Caution:** Before using the PWM macrocell, the programmer must ensure that the PWM clock in the Power Manager is enabled.

The PWM macrocell master clock, MCK, is divided in the clock generator module to provide different clocks available for all channels. Each channel can independently select one of the divided clocks.

The clock generator is divided in three blocks:

- a modulo n counter which provides 11 clocks:  $F_{MCK}$ ,  $F_{MCK}/2$ ,  $F_{MCK}/4$ ,  $F_{MCK}/8$ ,  $F_{MCK}/16$ ,  $F_{MCK}/32$ ,  $F_{MCK}/64$ ,  $F_{MCK}/128$ ,  $F_{MCK}/256$ ,  $F_{MCK}/512$ ,  $F_{MCK}/1024$
- two linear dividers (1, 1/2, 1/3, ... 1/255) that provide two separate clocks: clkA and clkB

Each linear divider can independently divide one of the clocks of the modulo n counter. The selection of the clock to be divided is made according to the PREA (PREB) field of the PWM Mode register (MR). The resulting clock clkA (clkB) is the clock selected divided by DIVA (DIVB) field value in the PWM Mode register (MR).

After a reset of the PWM controller, DIVA (DIVB) and PREA (PREB) in the PWM Mode register are set to 0. This implies that after reset clkA (clkB) are turned off.

At reset, all clocks provided by the modulo n counter are turned off except clock “clk”. This situation is also true when the PWM master clock is turned off through the Power Management Controller.

## 32.6.2 PWM Channel

### 32.6.2.1 Block Diagram

Figure 32-3. Functional View of the Channel Block Diagram

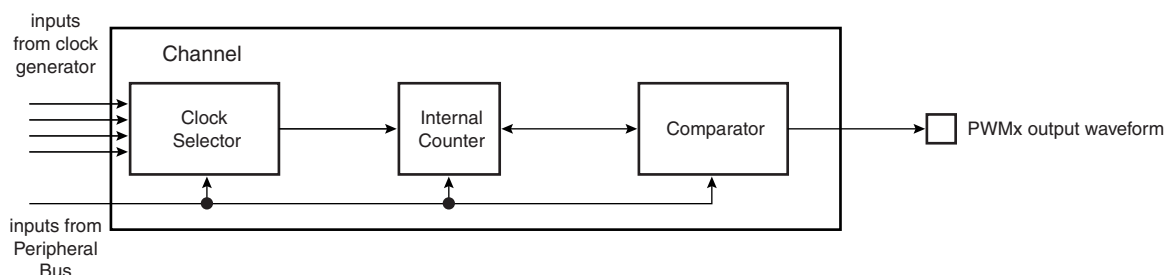

Each of the 7 channels is composed of three blocks:

- A clock selector which selects one of the clocks provided by the clock generator described in [Section 32.6.1 "PWM Clock Generator" on page 676](#).
- An internal counter clocked by the output of the clock selector. This internal counter is incremented or decremented according to the channel configuration and comparators events. The size of the internal counter is 20 bits.
- A comparator used to generate events according to the internal counter value. It also computes the PWMx output waveform according to the configuration.

### 32.6.2.2 Waveform Properties

The different properties of output waveforms are:

- the **internal clock selection**. The internal channel counter is clocked by one of the clocks provided by the clock generator described in the previous section. This channel parameter is defined in the CPRE field of the CMRx register. This field is reset at 0.
- the **waveform period**. This channel parameter is defined in the CPRD field of the CPRDx register.

- If the waveform is left aligned, then the output waveform period depends on the counter source clock and can be calculated:

By using the Master Clock (MCK) divided by an X given prescaler value

(with X being 1, 2, 4, 8, 16, 32, 64, 128, 256, 512, or 1024), the resulting period formula will be:

$$\frac{(X \times CPRD)}{MCK}$$

By using a Master Clock divided by one of both DIVA or DIVB divider, the formula becomes, respectively:

$$\frac{(CPRD \times DIVA)}{MCK} \text{ or } \frac{(CPRD \times DIVB)}{MCK}$$

If the waveform is center aligned then the output waveform period depends on the counter source clock and can be calculated:

By using the Master Clock (MCK) divided by an X given prescaler value

(with X being 1, 2, 4, 8, 16, 32, 64, 128, 256, 512, or 1024). The resulting period formula will be:

$$\frac{(2 \times X \times CPRD)}{MCK}$$

By using a Master Clock divided by one of both DIVA or DIVB divider, the formula becomes, respectively:

$$\frac{(2 \times CPRD \times DIVA)}{MCK} \text{ or } \frac{(2 \times CPRD \times DIVB)}{MCK}$$

- the **waveform duty cycle**. This channel parameter is defined in the CDTY field of the CDTYx register.

If the waveform is left aligned then:

$$\text{duty cycle} = \frac{(\text{period} - 1 / \text{fchannel\_x\_clock} \times \text{CDTY})}{\text{period}}$$

If the waveform is center aligned, then:

$$\text{duty cycle} = \frac{((\text{period}/2) - 1 / \text{fchannel\_x\_clock} \times \text{CDTY})}{(\text{period}/2)}$$

- the **waveform polarity**. At the beginning of the period, the signal can be at high or low level. This property is defined in the CPOL field of the CMRx register. By default the signal starts by a low level.
- the **waveform alignment**. The output waveform can be left or center aligned. Center aligned waveforms can be used to generate non overlapped waveforms. This property is defined in the CALG field of the CMRx register. The default mode is left aligned.

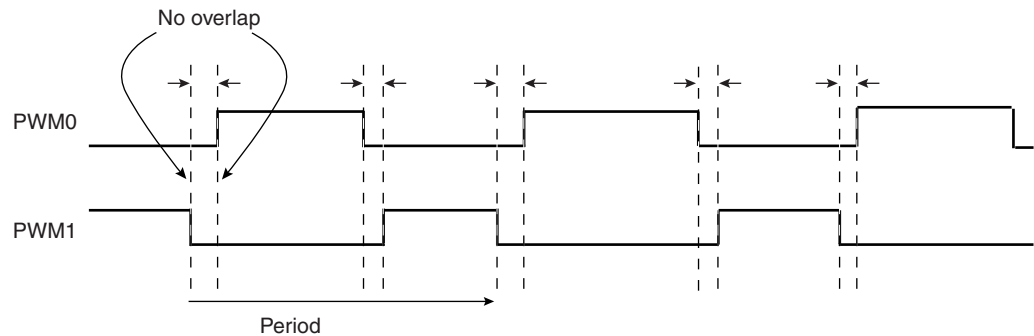
**Figure 32-4.** Non Overlapped Center Aligned Waveforms

Note: 1. See [Figure 32-5 on page 680](#) for a detailed description of center aligned waveforms. When center aligned, the internal channel counter increases up to CPRD and decreases down to 0. This ends the period.

When left aligned, the internal channel counter increases up to CPRD and is reset. This ends the period.

Thus, for the same CPRD value, the period for a center aligned channel is twice the period for a left aligned channel.

Waveforms are fixed at 0 when:

- CDTY = CPRD and CPOL = 0
- CDTY = 0 and CPOL = 1

Waveforms are fixed at 1 (once the channel is enabled) when:

- CDTY = 0 and CPOL = 0
- CDTY = CPRD and CPOL = 1

The waveform polarity must be set before enabling the channel. This immediately affects the channel output level. Changes on channel polarity are not taken into account while the channel is enabled.

Figure 32-5. Waveform Properties

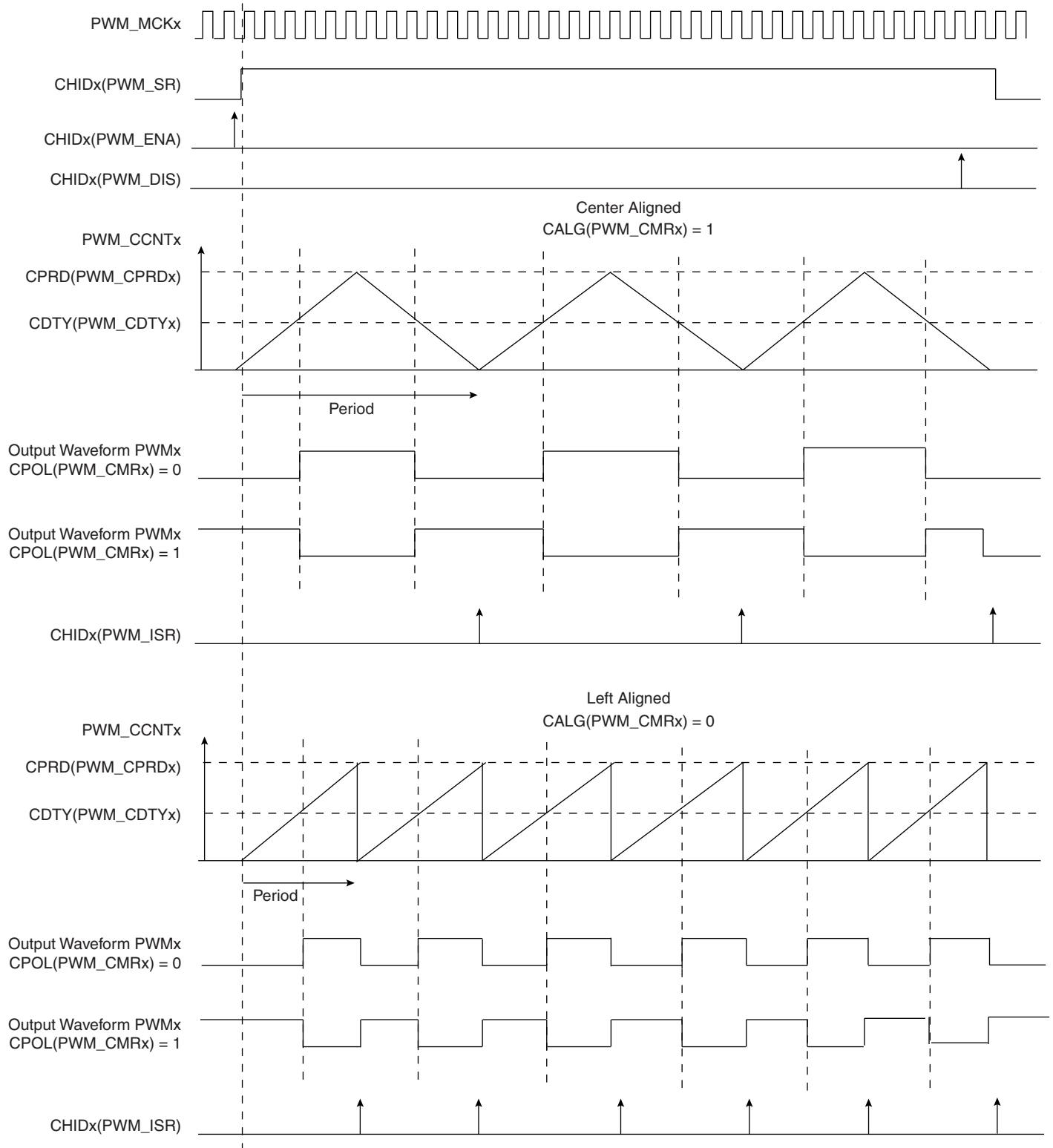



### 32.6.3 PWM Controller Operations

#### 32.6.3.1 Initialization

Before enabling the output channel, this channel must have been configured by the software application:

- Configuration of the clock generator if DIVA and DIVB are required
- Selection of the clock for each channel (CPRE field in the CMRx register)
- Configuration of the waveform alignment for each channel (CALG field in the CMRx register)
- Configuration of the period for each channel (CPRD in the CPRDx register). Writing in CPRDx Register is possible while the channel is disabled. After validation of the channel, the user must use CUPDx Register to update CPRDx as explained below.
- Configuration of the duty cycle for each channel (CDTY in the CDTYx register). Writing in CDTYx Register is possible while the channel is disabled. After validation of the channel, the user must use CUPDx Register to update CDTYx as explained below.
- Configuration of the output waveform polarity for each channel (CPOL in the CMRx register)
- Enable Interrupts (Writing CHIDx in the IER register)
- Enable the PWM channel (Writing CHIDx in the ENA register)

It is possible to synchronize different channels by enabling them at the same time by means of writing simultaneously several CHIDx bits in the ENA register.

In such a situation, all channels may have the same clock selector configuration and the same period specified.

#### 32.6.3.2 Source Clock Selection Criteria

The large number of source clocks can make selection difficult. The relationship between the value in the Period Register (CPRDx) and the Duty Cycle Register (CDTYx) can help the user in choosing. The event number written in the Period Register gives the PWM accuracy. The Duty Cycle quantum cannot be lower than  $1/CPRDx$  value. The higher the value of CPRDx, the greater the PWM accuracy.

For example, if the user sets 15 (in decimal) in CPRDx, the user is able to set a value between 1 up to 14 in CDTYx Register. The resulting duty cycle quantum cannot be lower than  $1/15$  of the PWM period.

#### 32.6.3.3 Changing the Duty Cycle or the Period

It is possible to modulate the output waveform duty cycle or period.

To prevent unexpected output waveform, the user must use the update register (PWM\_CUPDx) to change waveform parameters while the channel is still enabled. The user can write a new period value or duty cycle value in the update register (CUPDx). This register holds the new value until the end of the current cycle and updates the value for the next cycle. Depending on the CPD field in the CMRx register, CUPDx either updates CPRDx or CDTYx. Note that even if the update register is used, the period must not be smaller than the duty cycle.

**Figure 32-6.** Synchronized Period or Duty Cycle Update

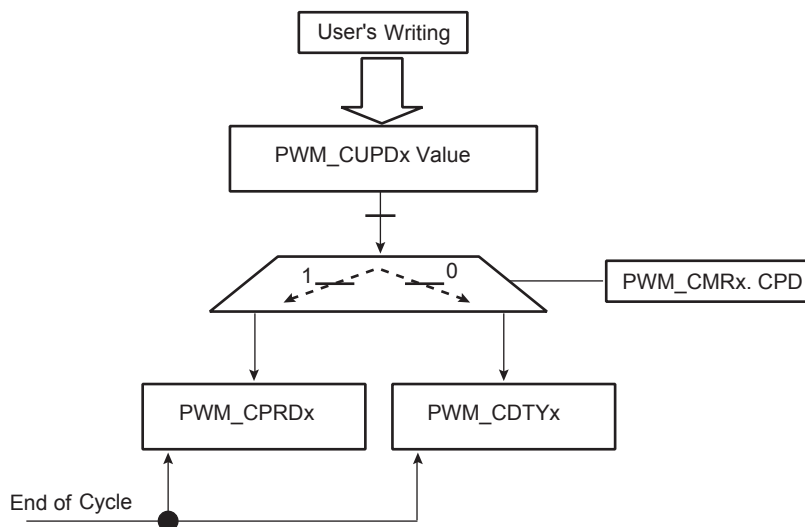

To prevent overwriting the CUPDx by software, the user can use status events in order to synchronize his software. Two methods are possible. In both, the user must enable the dedicated interrupt in IER at PWM Controller level.

The first method (polling method) consists of reading the relevant status bit in ISR Register according to the enabled channel(s). See [Figure 32-7](#).

The second method uses an Interrupt Service Routine associated with the PWM channel.

Note: Reading the ISR register automatically clears CHIDx flags.

**Figure 32-7.** Polling Method

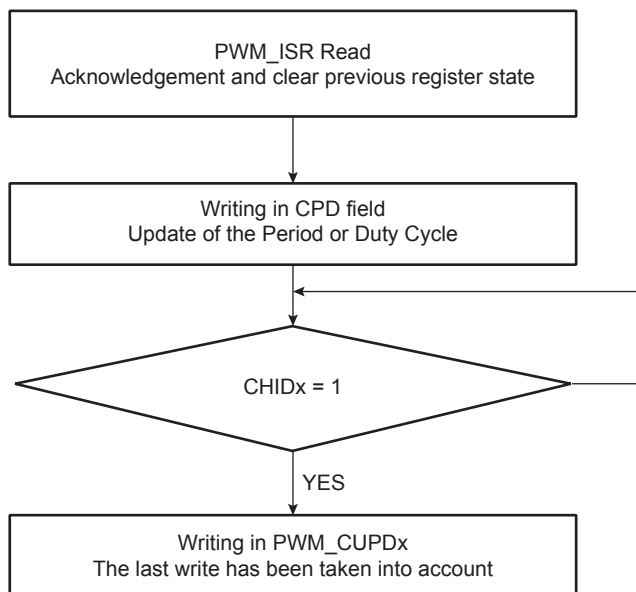

Note: Polarity and alignment can be modified only when the channel is disabled.

#### 32.6.3.4 *Interrupts*

Depending on the interrupt mask in the IMR register, an interrupt is generated at the end of the corresponding channel period. The interrupt remains active until a read operation in the ISR register occurs.

A channel interrupt is enabled by setting the corresponding bit in the IER register. A channel interrupt is disabled by setting the corresponding bit in the IDR register.

## 32.7 Pulse Width Modulation (PWM) Controller User Interface

### 32.7.1 Register Mapping

**Table 32-2.** PWM Controller Registers

Offset	Register	Name	Access	Peripheral Reset Value
0x00	PWM Mode Register	MR	Read/Write	0
0x04	PWM Enable Register	ENA	Write-only	-
0x08	PWM Disable Register	DIS	Write-only	-
0x0C	PWM Status Register	SR	Read-only	0
0x10	PWM Interrupt Enable Register	IER	Write-only	-
0x14	PWM Interrupt Disable Register	IDR	Write-only	-
0x18	PWM Interrupt Mask Register	IMR	Read-only	0
0x1C	PWM Interrupt Status Register	ISR	Read-only	0
0x4C - 0xF8	Reserved	-	-	-
0x4C - 0xFC	Reserved	-	-	-
0x100 - 0x1FC	Reserved			
0x200	Channel 0 Mode Register	CMR0	Read/Write	0x0
0x204	Channel 0 Duty Cycle Register	CDTY0	Read/Write	0x0
0x208	Channel 0 Period Register	CPRD0	Read/Write	0x0
0x20C	Channel 0 Counter Register	CCNT0	Read-only	0x0
0x210	Channel 0 Update Register	CUPD0	Write-only	-
...	Reserved			
0x220	Channel 1 Mode Register	CMR1	Read/Write	0x0
0x224	Channel 1 Duty Cycle Register	CDTY1	Read/Write	0x0
0x228	Channel 1 Period Register	CPRD1	Read/Write	0x0
0x22C	Channel 1 Counter Register	CCNT1	Read-only	0x0
0x230	Channel 1 Update Register	CUPD1	Write-only	-
...	...	...	...	...

## 32.7.2 PWM Mode Register

**Register Name:** MR  
**Access Type:** Read/Write

31	30	29	28	27	26	25	24
–	–	–	–	PREB			
23	22	21	20	19	18	17	16
DIVB							
15	14	13	12	11	10	9	8
–	–	–	–	PREA			
7	6	5	4	3	2	1	0
DIVA							

- **DIVA, DIVB: CLKA, CLKB Divide Factor**

DIVA, DIVB	CLKA, CLKB
0	CLKA, CLKB clock is turned off
1	CLKA, CLKB clock is clock selected by PREA, PREB
2-255	CLKA, CLKB clock is clock selected by PREA, PREB divided by DIVA, DIVB factor.

- **PREA, PREB**

PREA, PREB				Divider Input Clock
0	0	0	0	MCK.
0	0	0	1	MCK/2
0	0	1	0	MCK/4
0	0	1	1	MCK/8
0	1	0	0	MCK/16
0	1	0	1	MCK/32
0	1	1	0	MCK/64
0	1	1	1	MCK/128
1	0	0	0	MCK/256
1	0	0	1	MCK/512
1	0	1	0	MCK/1024
Other				Reserved

## 32.7.3 PWM Enable Register

**Register Name:** ENA

**Access Type:** Write-only

31	30	29	28	27	26	25	24
–	–	–	–	–	–	–	–
23	22	21	20	19	18	17	16
–	–	–	–	–	–	–	–
15	14	13	12	11	10	9	8
–	–	–	–	–	–	–	–
7	6	5	4	3	2	1	0
–	CHID6	CHID5	CHID4	CHID3	CHID2	CHID1	CHID0

- **CHIDx: Channel ID**

0 = No effect.

1 = Enable PWM output for channel x.

## 32.7.4 PWM Disable Register

**Register Name:** DIS

**Access Type:** Write-only

31	30	29	28	27	26	25	24
–	–	–	–	–	–	–	–
23	22	21	20	19	18	17	16
–	–	–	–	–	–	–	–
15	14	13	12	11	10	9	8
–	–	–	–	–	–	–	–
7	6	5	4	3	2	1	0
–	CHID6	CHID5	CHID4	CHID3	CHID2	CHID1	CHID0

- **CHIDx: Channel ID**

0 = No effect.

1 = Disable PWM output for channel x.

## 32.7.5 PWM Status Register

**Register Name:** SR

**Access Type:** Read-only

31	30	29	28	27	26	25	24
–	–	–	–	–	–	–	–
23	22	21	20	19	18	17	16
–	–	–	–	–	–	–	–
15	14	13	12	11	10	9	8
–	–	–	–	–	–	–	–
7	6	5	4	3	2	1	0
–	CHID6	CHID5	CHID4	CHID3	CHID2	CHID1	CHID0

- **CHIDx: Channel ID**

0 = PWM output for channel x is disabled.

1 = PWM output for channel x is enabled.



## 32.7.6 PWM Interrupt Enable Register

**Register Name:** IER

**Access Type:** Write-only

31	30	29	28	27	26	25	24
–	–	–	–	–	–	–	–
23	22	21	20	19	18	17	16
–	–	–	–	–	–	–	–
15	14	13	12	11	10	9	8
–	–	–	–	–	–	–	–
7	6	5	4	3	2	1	0
–	CHID6	CHID5	CHID4	CHID3	CHID2	CHID1	CHID0

• **CHIDx: Channel ID.**

0 = No effect.

1 = Enable interrupt for PWM channel x.

## 32.7.7 PWM Interrupt Disable Register

**Register Name:** IDR

**Access Type:** Write-only

31	30	29	28	27	26	25	24
–	–	–	–	–	–	–	–
23	22	21	20	19	18	17	16
–	–	–	–	–	–	–	–
15	14	13	12	11	10	9	8
–	–	–	–	–	–	–	–
7	6	5	4	3	2	1	0
–	CHID6	CHID5	CHID4	CHID3	CHID2	CHID1	CHID0

• **CHIDx: Channel ID.**

0 = No effect.

1 = Disable interrupt for PWM channel x.

## 32.7.8 PWM Interrupt Mask Register

**Register Name:** IMR

**Access Type:** Read-only

31	30	29	28	27	26	25	24
–	–	–	–	–	–	–	–
23	22	21	20	19	18	17	16
–	–	–	–	–	–	–	–
15	14	13	12	11	10	9	8
–	–	–	–	–	–	–	–
7	6	5	4	3	2	1	0
–	CHID6	CHID5	CHID4	CHID3	CHID2	CHID1	CHID0

- **CHIDx: Channel ID.**

0 = Interrupt for PWM channel x is disabled.

1 = Interrupt for PWM channel x is enabled.

## 32.7.9 PWM Interrupt Status Register

**Register Name:** ISR

**Access Type:** Read-only

31	30	29	28	27	26	25	24
–	–	–	–	–	–	–	–
23	22	21	20	19	18	17	16
–	–	–	–	–	–	–	–
15	14	13	12	11	10	9	8
–	–	–	–	–	–	–	–
7	6	5	4	3	2	1	0
–	CHID6	CHID5	CHID4	CHID3	CHID2	CHID1	CHID0

- **CHIDx: Channel ID**

0 = No new channel period since the last read of the ISR register.

1 = At least one new channel period since the last read of the ISR register.

Note: Reading ISR automatically clears CHIDx flags.

## 32.7.10 PWM Channel Mode Register

**Register Name:** CMRx

**Access Type:** Read/Write

31	30	29	28	27	26	25	24
–	–	–	–	–	–	–	–
23	22	21	20	19	18	17	16
–	–	–	–	–	–	–	–
15	14	13	12	11	10	9	8
–	–	–	–	–	CPD	CPOL	CALG
7	6	5	4	3	2	1	0
–	–	–	–	CPRE			

• **CPRE: Channel Pre-scaler**

CPRE				Channel Pre-scaler
0	0	0	0	MCK
0	0	0	1	MCK/2
0	0	1	0	MCK/4
0	0	1	1	MCK/8
0	1	0	0	MCK/16
0	1	0	1	MCK/32
0	1	1	0	MCK/64
0	1	1	1	MCK/128
1	0	0	0	MCK/256
1	0	0	1	MCK/512
1	0	1	0	MCK/1024
1	0	1	1	CLKA
1	1	0	0	CLKB
Other				Reserved

• **CALG: Channel Alignment**

0 = The period is left aligned.

1 = The period is center aligned.

• **CPOL: Channel Polarity**

0 = The output waveform starts at a low level.

1 = The output waveform starts at a high level.

- **CPD: Channel Update Period**

0 = Writing to the CUPDx will modify the duty cycle at the next period start event.

1 = Writing to the CUPDx will modify the period at the next period start event.

32.7.11 PWM Channel Duty Cycle Register

Register Name: CDTYx

Access Type: Read/Write

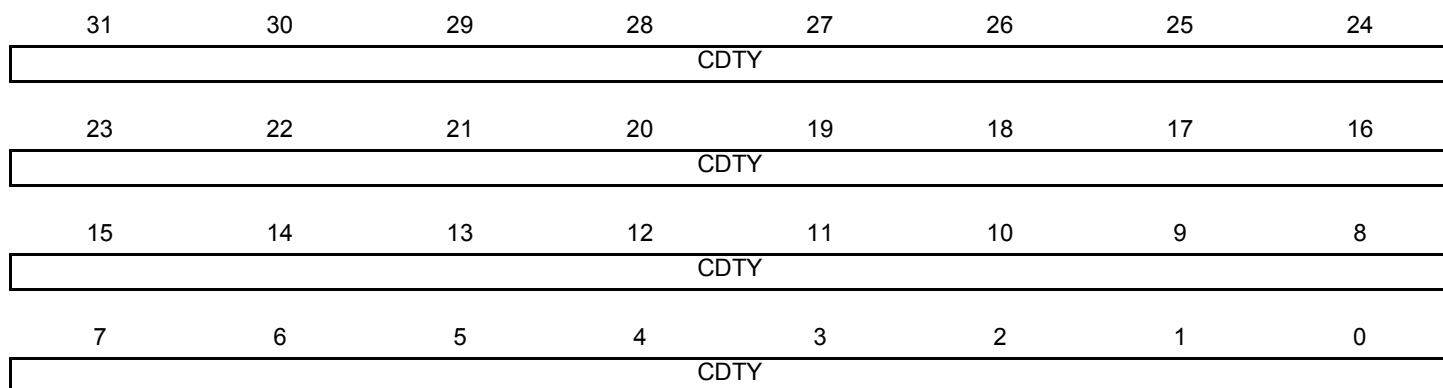

Only the first 20 bits (internal channel counter size) are significant.

- **CDTY: Channel Duty Cycle**

Defines the waveform duty cycle. This value must be defined between 0 and CPRD (CPRx).

## 32.7.12 PWM Channel Period Register

**Register Name:** CPRDx

**Access Type:** Read/Write

31	30	29	28	27	26	25	24
CPRD							
23	22	21	20	19	18	17	16
CPRD							
15	14	13	12	11	10	9	8
CPRD							
7	6	5	4	3	2	1	0
CPRD							

Only the first 20 bits (internal channel counter size) are significant.

- **CPRD: Channel Period**

If the waveform is left-aligned, then the output waveform period depends on the counter source clock and can be calculated:

- By using the Master Clock (MCK) divided by an X given prescaler value (with X being 1, 2, 4, 8, 16, 32, 64, 128, 256, 512, or 1024). The resulting period formula will be:

$$\frac{(X \times CPRD)}{MCK}$$

- By using a Master Clock divided by one of both DIVA or DIVB divider, the formula becomes, respectively:

$$\frac{(CPRD \times DIVA)}{MCK} \text{ or } \frac{(CPRD \times DIVB)}{MCK}$$

If the waveform is center-aligned, then the output waveform period depends on the counter source clock and can be calculated:

- By using the Master Clock (MCK) divided by an X given prescaler value (with X being 1, 2, 4, 8, 16, 32, 64, 128, 256, 512, or 1024). The resulting period formula will be:

$$\frac{(2 \times X \times CPRD)}{MCK}$$

- By using a Master Clock divided by one of both DIVA or DIVB divider, the formula becomes, respectively:

$$\frac{(2 \times CPRD \times DIVA)}{MCK} \text{ or } \frac{(2 \times CPRD \times DIVB)}{MCK}$$



## 32.7.13 PWM Channel Counter Register

**Register Name:** CCNTx

**Access Type:** Read-only

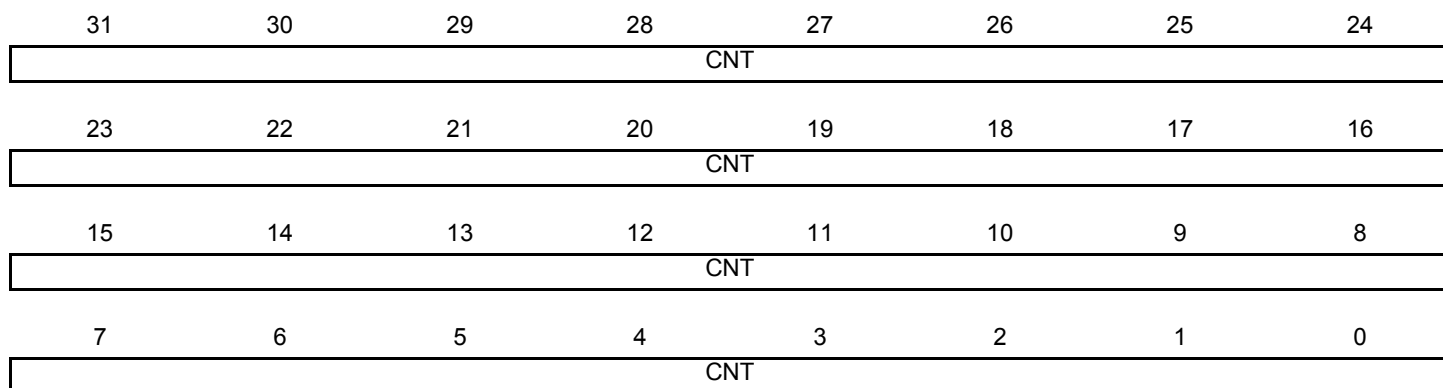

- **CNT: Channel Counter Register**

Internal counter value. This register is reset when:

- the channel is enabled (writing CHIDx in the ENA register).
- the counter reaches CPRD value defined in the CPRDx register if the waveform is left aligned.

## 32.7.14 PWM Channel Update Register

**Register Name:** CUPDx

**Access Type:** Write-only

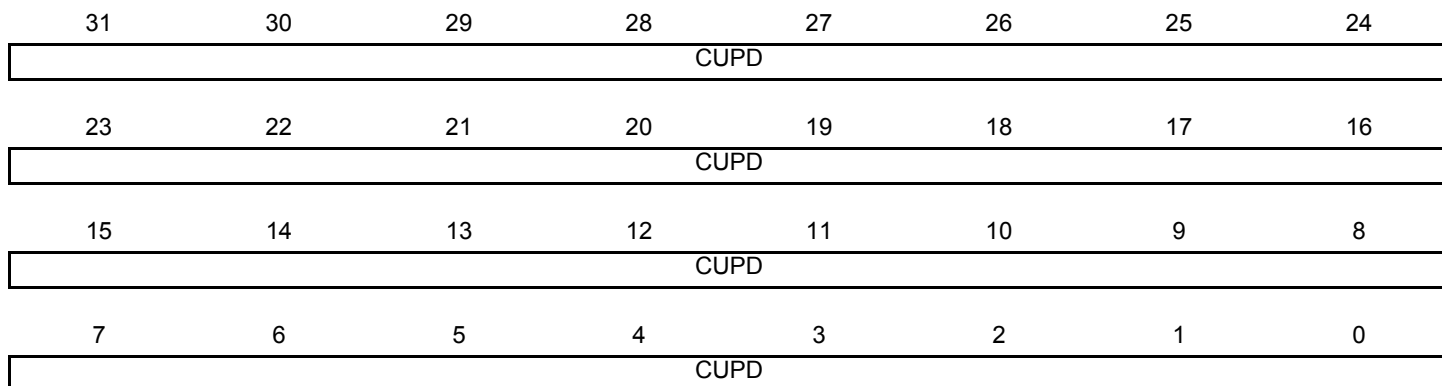

This register acts as a double buffer for the period or the duty cycle. This prevents an unexpected waveform when modifying the waveform period or duty-cycle.

Only the first 20 bits (internal channel counter size) are significant.

CPD (CMRx Register)	
0	The duty-cycle (CDTY in the CDTYx register) is updated with the CUPD value at the beginning of the next period.
1	The period (CPRD in the CPRDx register) is updated with the CUPD value at the beginning of the next period.

## 33. Analog-to-Digital Converter (ADC)

Rev: 1.0.0.3

### 33.1 Features

- **Integrated Multiplexer Offering Up to Eight Independent Analog Inputs**
- **Individual Enable and Disable of Each Channel**
- **Hardware or Software Trigger**
  - External Trigger Pin
  - Timer Counter Outputs (Corresponding TIOA Trigger)
- **PDC Support**
- **Possibility of ADC Timings Configuration**
- **Sleep Mode and Conversion Sequencer**
  - Automatic Wakeup on Trigger and Back to Sleep Mode after Conversions of all Enabled Channels

### 33.2 Overview

The ADC is based on a Successive Approximation Register (SAR) 10-bit Analog-to-Digital Converter (ADC). It also integrates an ADC\_NB\_CHANNELS-to-1 analog multiplexer, making possible the analog-to-digital conversions of ADC\_NB\_CHANNELS analog lines.

The ADC supports an 8-bit or 10-bit resolution mode, and conversion results are reported in a common register for all channels, as well as in a channel-dedicated register. Software trigger, external trigger on rising edge of the TRIGGER pin or internal triggers from Timer Counter output(s) are configurable.

The ADC also integrates a Sleep Mode and a conversion sequencer and connects with a PDC channel. These features reduce both power consumption and processor intervention.

Finally, the user can configure ADC timings, such as Startup Time and Sample & Hold Time.



### 33.5.2 Analog Inputs

The analog input pins can be multiplexed with PIO lines. In this case, the assignment of the ADC input is automatically done as soon as the corresponding channel is enabled by writing the CHER register. By default, after reset, the PIO line is configured as input with its pull-up enabled and the ADC input is connected to the GND.

### 33.5.3 Power Manager

The ADC is automatically clocked after the first conversion in Normal Mode. In Sleep Mode, the ADC clock is automatically stopped after each conversion. As the logic is small and the ADC cell can be put into Sleep Mode, the Power Manager(PM) has no effect on the ADC behavior.

### 33.5.4 Interrupt Controller

The ADC interrupt line is connected on one of the internal sources of the Interrupt Controller. Using the ADC interrupt requires the INTC to be programmed first.

### 33.5.5 Timer Triggers

Timer Counters may or may not be used as hardware triggers depending on user requirements. Thus, some or all of the timer counters may be non-connected.

### 33.5.6 Conversion Performances

For performance and electrical characteristics of the ADC, see the DC Characteristics section.

## 33.6 Functional Description

### 33.6.1 Analog-to-digital Conversion

The ADC uses the ADC Clock to perform conversions. Converting a single analog value to a 10-bit digital data requires Sample and Hold Clock cycles as defined in the field SHTIM of the MR register and 10 ADC Clock cycles. The ADC Clock frequency is selected in the PRESCAL field of the MR register.

The ADC clock range is between  $CLK\_ADC/2$ , if PRESCAL is 0, and  $CLK\_ADC/128$ , if PRESCAL is set to 63 (0x3F). PRESCAL must be programmed in order to provide an ADC clock frequency according to the parameters given in the Product definition section.

### 33.6.2 Conversion Reference

The conversion is performed on a full range between 0V and Analog inputs between these voltages convert to values based on a linear conversion.

### 33.6.3 Conversion Resolution

The ADC supports 8-bit or 10-bit resolutions. The 8-bit selection is performed by setting the bit LOWRES in the ADC Mode Register (MR). By default, after a reset, the resolution is the highest and the DATA field in the data registers is fully used. By setting the bit LOWRES, the ADC switches in the lowest resolution and the conversion results can be read in the eight lowest significant bits of the data registers. The two highest bits of the DATA field in the corresponding CDR register and of the LDATA field in the LCDR register read 0.

Moreover, when a PDC channel is connected to the ADC, 10-bit resolution sets the transfer request sizes to 16-bit. Setting the bit LOWRES automatically switches to 8-bit data transfers. In this case, the destination buffers are optimized.

## 33.6.4 Conversion Results

When a conversion is completed, the resulting 10-bit digital value is stored in the Channel Data Register (CDR) of the current channel and in the ADC Last Converted Data Register (LCDR).

The channel EOC bit in the Status Register (SR) is set and the DRDY is set. In the case of a connected PDC channel, DRDY rising triggers a data transfer request. In any case, either EOC and DRDY can trigger an interrupt.

Reading one of the CDR registers clears the corresponding EOC bit. Reading LCDR clears the DRDY bit and the EOC bit corresponding to the last converted channel.

**Figure 33-2.** EOCx and DRDY Flag Behavior

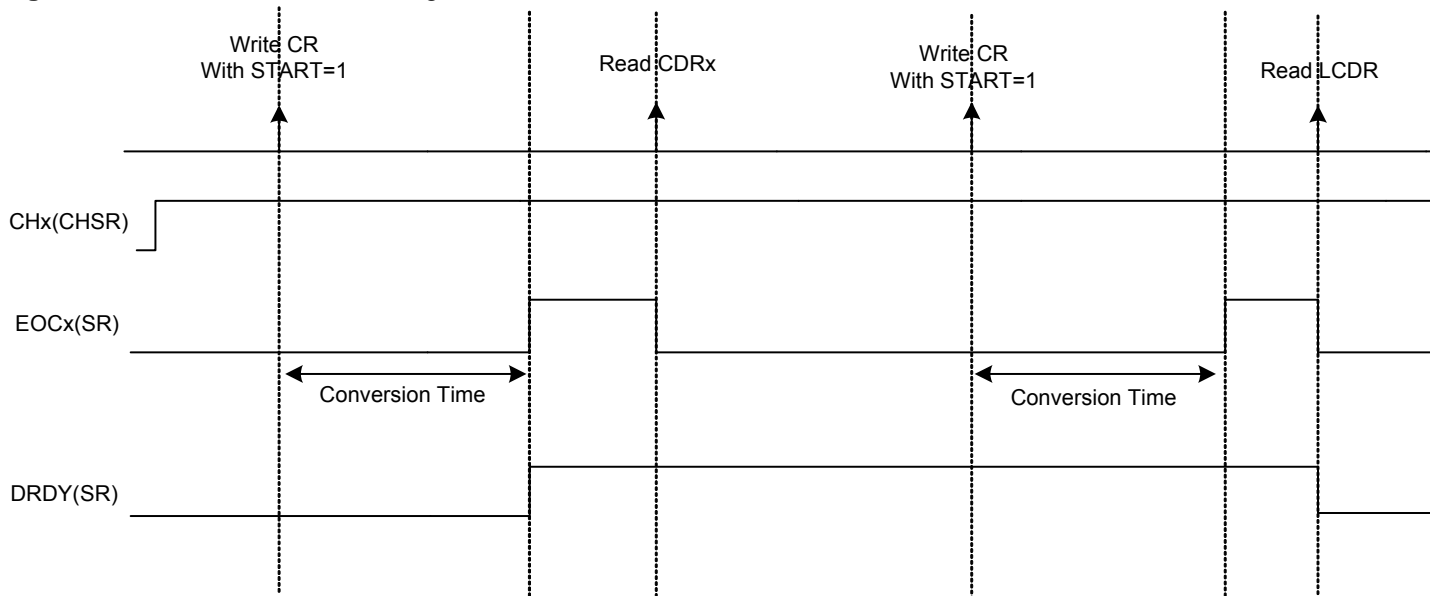

If the CDR is not read before further incoming data is converted, the corresponding Overrun Error (OVRE) flag is set in the Status Register (SR).

In the same way, new data converted when DRDY is high sets the bit GOVRE (General Overrun Error) in SR.

The OVRE and GOVRE flags are automatically cleared when SR is read.

**Figure 33-3.** GOVRE and OVREx Flag Behavior

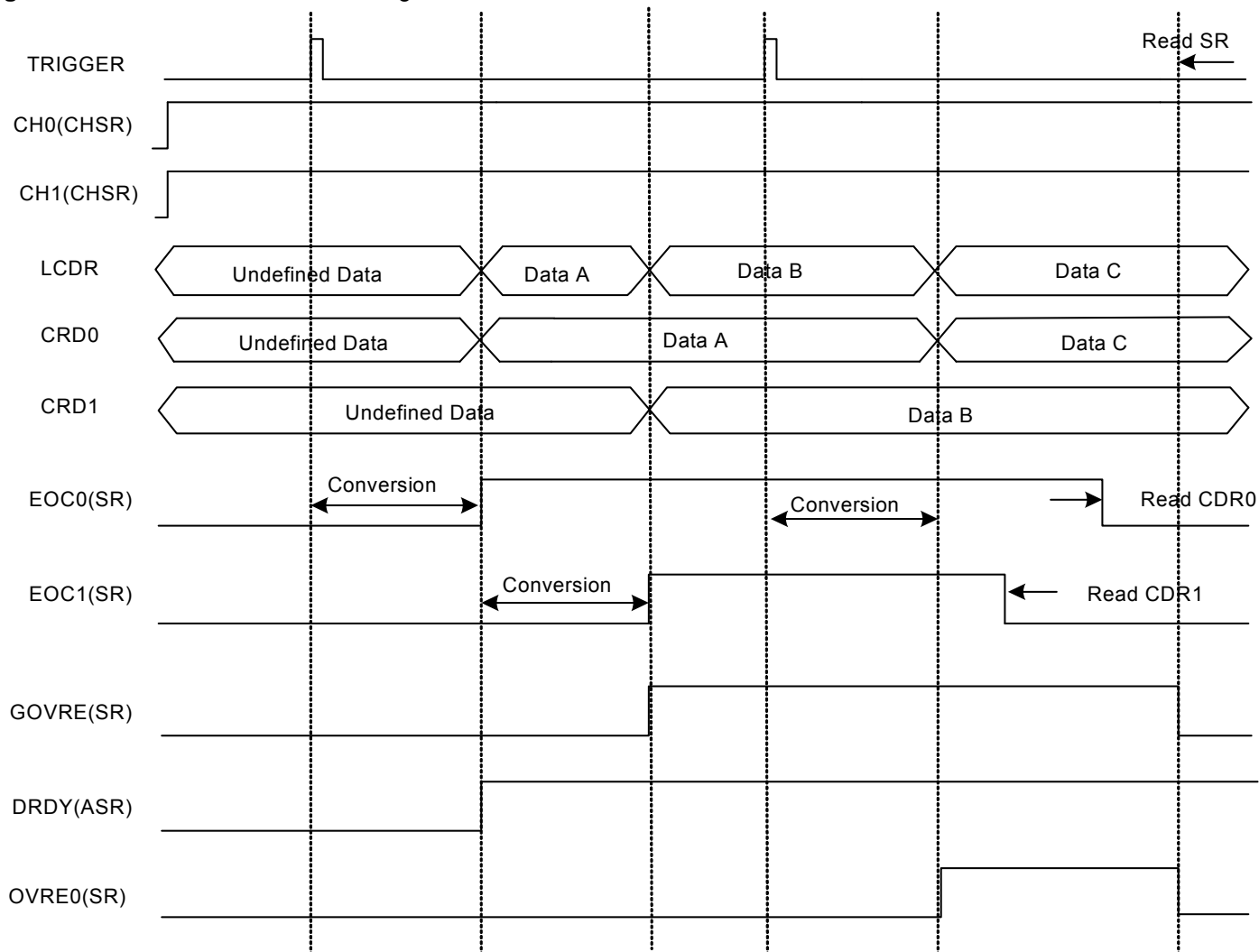

**Warning:** If the corresponding channel is disabled during a conversion or if it is disabled and then reenabled during a conversion, its associated data and its corresponding EOC and OVRE flags in SR are unpredictable.



### 33.6.5 Conversion Triggers

Conversions of the active analog channels are started with a software or a hardware trigger. The software trigger is provided by writing the Control Register (CR) with the bit START at 1.

The hardware trigger can be one of the TIOA outputs of the Timer Counter channels, or the external trigger input of the ADC (TRIGGER). The hardware trigger is selected with the field TRGSEL in the Mode Register (MR). The selected hardware trigger is enabled with the bit TRGEN in the Mode Register (MR).

If a hardware trigger is selected, the start of a conversion is detected at each rising edge of the selected signal. If one of the TIOA outputs is selected, the corresponding Timer Counter channel must be programmed in Waveform Mode.

Only one start command is necessary to initiate a conversion sequence on all the channels. The ADC hardware logic automatically performs the conversions on the active channels, then waits for a new request. The Channel Enable (CHER) and Channel Disable (CHDR) Registers enable the analog channels to be enabled or disabled independently.

If the ADC is used with a PDC, only the transfers of converted data from enabled channels are performed and the resulting data buffers should be interpreted accordingly.

**Warning:** Enabling hardware triggers does not disable the software trigger functionality. Thus, if a hardware trigger is selected, the start of a conversion can be initiated either by the hardware or the software trigger.

### 33.6.6 Sleep Mode and Conversion Sequencer

The ADC Sleep Mode maximizes power saving by automatically deactivating the ADC when it is not being used for conversions. Sleep Mode is selected by setting the bit SLEEP in the Mode Register MR.

The SLEEP mode is automatically managed by a conversion sequencer, which can automatically process the conversions of all channels at lowest power consumption.

When a start conversion request occurs, the ADC is automatically activated. As the analog cell requires a start-up time, the logic waits during this time and starts the conversion on the enabled channels. When all conversions are complete, the ADC is deactivated until the next trigger. Triggers occurring during the sequence are not taken into account.

The conversion sequencer allows automatic processing with minimum processor intervention and optimized power consumption. Conversion sequences can be performed periodically using a Timer/Counter output. The periodic acquisition of several samples can be processed automatically without any intervention of the processor thanks to the PDC.

Note: The reference voltage pins always remain connected in normal mode as in sleep mode.

### 33.6.7 ADC Timings

Each ADC has its own minimal Startup Time that is programmed through the field STARTUP in the Mode Register MR.

In the same way, a minimal Sample and Hold Time is necessary for the ADC to guarantee the best converted final value between two channels selection. This time has to be programmed through the bitfield SHTIM in the Mode Register MR.

**Warning:** No input buffer amplifier to isolate the source is included in the ADC. This must be taken into consideration to program a precise value in the SHTIM field. See the section, ADC Characteristics in the product datasheet.

### 33.7 User Interface

**Table 33-2.** ADC Register Mapping

Offset	Register	Name	Access	Reset State
0x00	Control Register	CR	Write-only	–
0x04	Mode Register	MR	Read/Write	0x00000000
0x10	Channel Enable Register	CHER	Write-only	–
0x14	Channel Disable Register	CHDR	Write-only	–
0x18	Channel Status Register	CHSR	Read-only	0x00000000
0x1C	Status Register	SR	Read-only	0x000C0000
0x20	Last Converted Data Register	LCDR	Read-only	0x00000000
0x24	Interrupt Enable Register	IER	Write-only	–
0x28	Interrupt Disable Register	IDR	Write-only	–
0x2C	Interrupt Mask Register	IMR	Read-only	0x00000000
0x30	Channel Data Register 0	CDR0	Read-only	0x00000000
...	...(if implemented)	...	...	...
0x4C	Channel Data Register 7(if implemented)	CDR7	Read-only	0x00000000
0xFC	Version Register	VERSION	Read-only	–

## 33.7.1 Control Register

**Name:** CR  
**Access Type:** Write-only  
**Offset:** 0x00  
**Reset Value:** –

31	30	29	28	27	26	25	24
–	–	–	–	–	–	–	–
23	22	21	20	19	18	17	16
–	–	–	–	–	–	–	–
15	14	13	12	11	10	9	8
–	–	–	–	–	–	–	–
7	6	5	4	3	2	1	0
–	–	–	–	–	–	START	SWRST

- **START: Start Conversion**

0 = No effect.

1 = Begins analog-to-digital conversion.

- **SWRST: Software Reset**

0 = No effect.

1 = Resets the ADC simulating a hardware reset.

## 33.7.2 Mode Register

**Name:** MR  
**Access Type:** Read/Write  
**Offset:** 0x04  
**Reset Value:** 0x00000000

31	30	29	28	27	26	25	24
–	–	–	–	SHTIM			
23	22	21	20	19	18	17	16
–	–	–	STARTUP				
15	14	13	12	11	10	9	8
–	–	PRESCAL					
7	6	5	4	3	2	1	0
–	–	SLEEP	LOWRES	TRGSEL			TRGEN

- **SHTIM: Sample & Hold Time**  
 Sample & Hold Time = (SHTIM+1) / ADCClock
- **STARTUP: Start Up Time**  
 Startup Time = (STARTUP+1) \* 8 / ADCClock
- **PRESCAL: Prescaler Rate Selection**  
 ADCClock = CLK\_ADC / ( (PRESCAL+1) \* 2 )
- **SLEEP: Sleep Mode**

SLEEP	Selected Mode
0	Normal Mode
1	Sleep Mode

- **LOWRES: Resolution**

LOWRES	Selected Resolution
0	10-bit resolution
1	8-bit resolution

- **TRGSEL: Trigger Selection**

TRGSEL			Selected TRGSEL
0	0	0	Internal Trigger 0, depending of chip integration
0	0	1	Internal Trigger 1, depending of chip integration
0	1	0	Internal Trigger 2, depending of chip integration
0	1	1	Internal Trigger 3, depending of chip integration
1	0	0	Internal Trigger 4, depending of chip integration

TRGSEL			Selected TRGSEL
1	0	1	Internal Trigger 5, depending of chip integration
1	1	0	External trigger
1	1	1	Reserved

- **TRGEN: Trigger Enable**

TRGEN	Selected TRGEN
0	Hardware triggers are disabled. Starting a conversion is only possible by software.
1	Hardware trigger selected by TRGSEL field is enabled.

### 33.7.3 Channel Enable Register

**Name:** CHER

**Access Type:** Write-only

**Offset:** 0x10

**Reset Value:** –

31	30	29	28	27	26	25	24
–	–	–	–	–	–	–	–
23	22	21	20	19	18	17	16
–	–	–	–	–	–	–	–
15	14	13	12	11	10	9	8
–	–	–	–	–	–	–	–
7	6	5	4	3	2	1	0
CH2	CH6	CH5	CH4	CH3	CH2	CH1	CH0

- **CHx: Channel x Enable**

0 = No effect.

1 = Enables the corresponding channel(if implemented).

## 33.7.4 Channel Disable Register

**Name:** CHDR

**Access Type:** Write-only

**Offset:** 0x14

**Reset Value:** –

31	30	29	28	27	26	25	24
–	–	–	–	–	–	–	–
23	22	21	20	19	18	17	16
–	–	–	–	–	–	–	–
15	14	13	12	11	10	9	8
–	–	–	–	–	–	–	–
7	6	5	4	3	2	1	0
CH7	CH6	CH5	CH4	CH3	CH2	CH1	CH0

- **CHx: Channel x Disable**

0 = No effect.

1 = Disables the corresponding channel(if implemented).

**Warning:** If the corresponding channel is disabled during a conversion or if it is disabled then reenabled during a conversion, its associated data and its corresponding EOC and OVRE flags in SR are unpredictable.



## 33.7.5 Channel Status Register

**Name:** CHSR  
**Access Type:** Read-only  
**Offset:** 0x18  
**Reset Value:** 0x00000000

31	30	29	28	27	26	25	24
–	–	–	–	–	–	–	–
23	22	21	20	19	18	17	16
–	–	–	–	–	–	–	–
15	14	13	12	11	10	9	8
–	–	–	–	–	–	–	–
7	6	5	4	3	2	1	0
CH7	CH6	CH5	CH4	CH3	CH2	CH1	CH0

- **CHx: Channel x Status**

0 = Corresponding channel is disabled(if implemented).

1 = Corresponding channel is enabled(if implemented).

## 33.7.6 Status Register

**Name:** SR  
**Access Type:** Read-only  
**Offset:** 0x1C  
**Reset Value:** 0x000C0000

31	30	29	28	27	26	25	24
–	–	–	–	–	–	–	–
23	22	21	20	19	18	17	16
–	–	–	–	RXBUFF	ENDRX	GOVRE	DRDY
15	14	13	12	11	10	9	8
OVRE7	OVRE6	OVRE5	OVRE4	OVRE3	OVRE2	OVRE1	OVRE0
7	6	5	4	3	2	1	0
EOC7	EOC6	EOC5	EOC4	EOC3	EOC2	EOC1	EOC0

- **RXBUFF: RX Buffer Full**

0 = RCR or RNCR have a value other than 0.

1 = Both RCR and RNCR have a value of 0.

- **ENDRX: End of RX Buffer**

0 = The Receive Counter Register has not reached 0 since the last write in RCR or RNCR.

1 = The Receive Counter Register has reached 0 since the last write in RCR or RNCR.

- **GOVRE: General Overrun Error**

0 = No General Overrun Error occurred since the last read of SR.

1 = At least one General Overrun Error has occurred since the last read of SR.

- **DRDY: Data Ready**

0 = No data has been converted since the last read of LCDR.

1 = At least one data has been converted and is available in LCDR.

- **OVREx: Overrun Error x**

0 = No overrun error on the corresponding channel(if implemented) since the last read of SR.

1 = There has been an overrun error on the corresponding channel (if implemented) since the last read of SR.

- **EOCx: End of Conversion x**

0 = Corresponding analog channel (if implemented) is disabled, or the conversion is not finished.

1 = Corresponding analog channel (if implemented) is enabled and conversion is complete.

## 33.7.7 Last Converted Data Register

**Name:** LCDR  
**Access Type:** Read-only  
**Offset:** 0x20  
**Reset Value:** 0x00000000

31	30	29	28	27	26	25	24
–	–	–	–	–	–	–	–
23	22	21	20	19	18	17	16
–	–	–	–	–	–	–	–
15	14	13	12	11	10	9	8
–	–	–	–	–	–	LDATA	
7	6	5	4	3	2	1	0
LDATA							

- **LDATA: Last Data Converted**

The analog-to-digital conversion data is placed into this register at the end of a conversion and remains until a new conversion is completed.

## 33.7.8 Interrupt Enable Register

**Name:** IER

**Access Type:** Write-only

**Offset:** 0x24

**Reset Value:** –

31	30	29	28	27	26	25	24
–	–	–	–	–	–	–	–
23	22	21	20	19	18	17	16
–	–	–	–	RXBUFF	ENDRX	GOVRE	DRDY
15	14	13	12	11	10	9	8
OVRE7	OVRE6	OVRE5	OVRE4	OVRE3	OVRE2	OVRE1	OVRE0
7	6	5	4	3	2	1	0
EOC7	EOC6	EOC5	EOC4	EOC3	EOC2	EOC1	EOC0

- **RXBUFF: Receive Buffer Full Interrupt Enable**

0 = No effect.

1 = Enables the corresponding interrupt. ENDRX: End of Receive Buffer Interrupt Enable

- **GOVRE: General Overrun Error Interrupt Enable**

- **DRDY: Data Ready Interrupt Enable**

- **OVREx: Overrun Error Interrupt Enable x**

- **EOCx: End of Conversion Interrupt Enable x**

## 33.7.9 Interrupt Disable Register

**Name:** IDR

**Access Type:** Write-only

**Offset:** 0x28

**Reset Value:** –

31	30	29	28	27	26	25	24
–	–	–	–	–	–	–	–
23	22	21	20	19	18	17	16
–	–	–	–	RXBUFF	ENDRX	GOVRE	DRDY
15	14	13	12	11	10	9	8
OVRE7	OVRE6	OVRE5	OVRE4	OVRE3	OVRE2	OVRE1	OVRE0
7	6	5	4	3	2	1	0
EOC7	EOC6	EOC5	EOC4	EOC3	EOC2	EOC1	EOC0

- **RXBUFF: Receive Buffer Full Interrupt Disable**

0 = No effect.

1 = Disables the corresponding interrupt.

- **ENDRX: End of Receive Buffer Interrupt Disable**
- **GOVRE: General Overrun Error Interrupt Disable**
- **DRDY: Data Ready Interrupt Disable**
- **OVREx: Overrun Error Interrupt Disable x**
- **EOCx: End of Conversion Interrupt Disable x**

### 33.7.10 Interrupt Mask Register

**Name:** IMR  
**Access Type:** Read-only  
**Offset:** 0x2C  
**Reset Value:** 0x00000000

31	30	29	28	27	26	25	24
–	–	–	–	–	–	–	–
23	22	21	20	19	18	17	16
–	–	–	–	RXBUFF	ENDRX	GOVRE	DRDY
15	14	13	12	11	10	9	8
OVRE7	OVRE6	OVRE5	OVRE4	OVRE3	OVRE2	OVRE1	OVRE0
7	6	5	4	3	2	1	0
EOC7	EOC6	EOC5	EOC4	EOC3	EOC2	EOC1	EOC0

- **RXBUFF: Receive Buffer Full Interrupt Mask**  
 0 = The corresponding interrupt is disabled.  
 1 = The corresponding interrupt is enabled.
- **ENDRX: End of Receive Buffer Interrupt Mask**
- **GOVRE: General Overrun Error Interrupt Mask**
- **DRDY: Data Ready Interrupt Mask**
- **OVREx: Overrun Error Interrupt Mask x**
- **EOCx: End of Conversion Interrupt Mask x**

## 33.7.11 Channel Data Register

**Name:** CDRx  
**Access Type:** Read-only  
**Offset:** 0x2C-0x4C  
**Reset Value:** 0x00000000

31	30	29	28	27	26	25	24
–	–	–	–	–	–	–	–
23	22	21	20	19	18	17	16
–	–	–	–	–	–	–	–
15	14	13	12	11	10	9	8
–	–	–	–	–	–	DATA	
7	6	5	4	3	2	1	0
DATA							

- DATA: Converted Data**

The analog-to-digital conversion data is placed into this register at the end of a conversion and remains until a new conversion is completed. The Convert Data Register (CDR) is only loaded if the corresponding analog channel is enabled.

## 33.7.12 Version Register

**Name:** VERSION

**Access Type:** Read-only

**Offset:** 0xFC

**Reset Value:** –

31	30	29	28	27	26	25	24
–	–	–	–	–	–	–	–
23	22	21	20	19	18	17	16
–	–	–	–	VARIANT			
15	14	13	12	11	10	9	8
–	–	–	–	VERSION[11:8]			
7	6	5	4	3	2	1	0
VERSION[7:0]							

- **VARIANT: Variant Number**

Reserved. No functionality associated.

- **VERSION: Version Number**

Version number of the module. No functionality associated.



## 34. Audio Bitstream DAC (ABDAC)

Rev: 1.0.1.1

### 34.1 Features

- Digital Stereo DAC
- Oversampled D/A conversion architecture
  - Oversampling ratio fixed 128x
  - FIR equalization filter
  - Digital interpolation filter: Comb4
  - 3rd Order Sigma-Delta D/A converters
- Digital bitstream outputs
- Parallel interface
- Connected to DMA Controller for background transfer without CPU intervention

### 34.2 Description

The Audio Bitstream DAC converts a 16-bit sample value to a digital bitstream with an average value proportional to the sample value. Two channels are supported, making the Audio Bitstream DAC particularly suitable for stereo audio. Each channel has a pair of complementary digital outputs, DACn and DACn\_N, which can be connected to an external high input impedance amplifier.

The Audio Bitstream DAC is comprised of two 3rd order Sigma Delta D/A converter with an oversampling ratio of 128. The samples are upsampled with a 4th order Sinc interpolation filter (Comb4) before being input to the Sigma Delta Modulator. In order to compensate for the pass band frequency response of the interpolation filter and flatten the overall frequency response, the input to the interpolation filter is first filtered with a simple 3-tap FIR filter. The total frequency response of the Equalization FIR filter and the interpolation filter is given in [Figure 34-2 on page 733](#). The digital output bitstreams from the Sigma Delta Modulators should be low-pass filtered to remove high frequency noise inserted by the Modulation process.

The output DACn and DACn\_N should be as ideal as possible before filtering, to achieve the best SNR quality. The output can be connected to a class D amplifier output stage, or it can be low pass filtered and connected to a high input impedance amplifier. A simple 1st order or higher low pass filter that filters all the frequencies above 50 kHz should be adequate.

### 34.3 Block Diagram

Figure 34-1. Functional Block Diagram

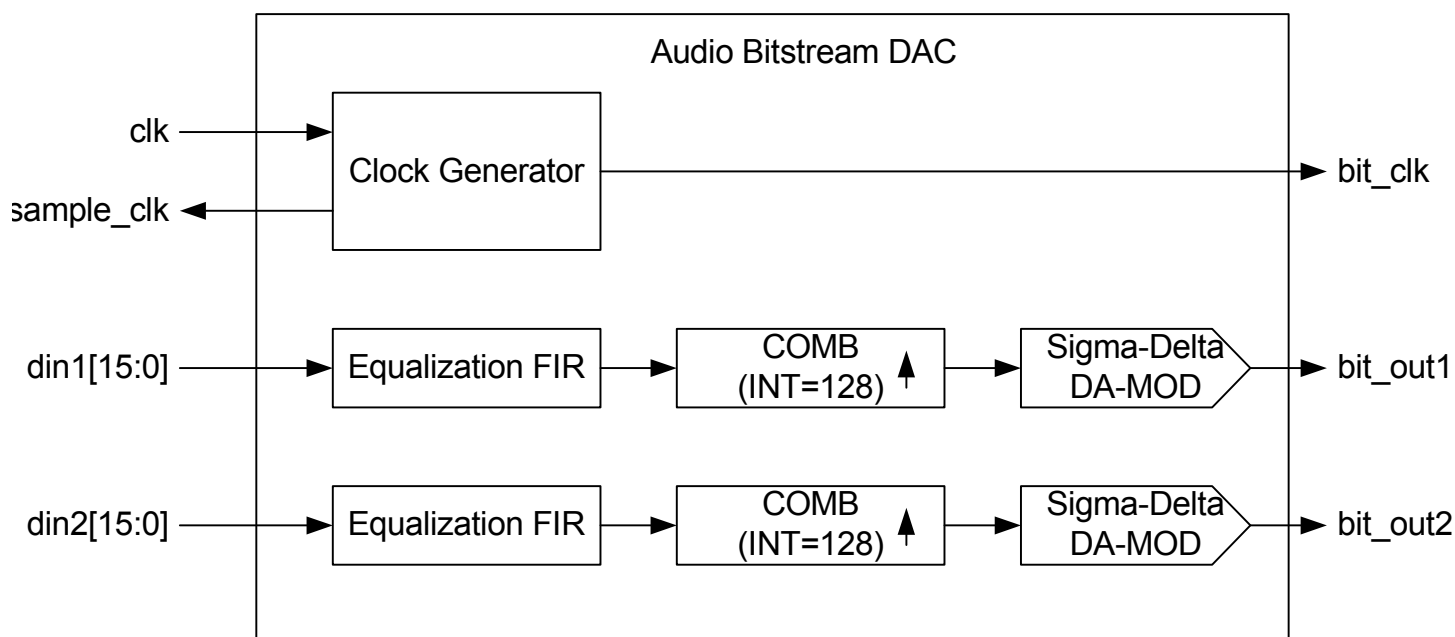

### 34.4 Pin Name List

Table 34-1. I/O Lines Description

Pin Name	Pin Description	Type
DATA0	Output from Audio Bitstream DAC Channel 0	Output
DATA1	Output from Audio Bitstream DAC Channel 1	Output
DATAN0	Inverted output from Audio Bitstream DAC Channel 0	Output
DATAN1	Inverted output from Audio Bitstream DAC Channel 1	Output

### 34.5 Product Dependencies

#### 34.5.1 I/O Lines

The output pins used for the output bitstream from the Audio Bitstream DAC may be multiplexed with PIO lines.

Before using the Audio Bitstream DAC, the PIO controller must be configured in order for the Audio Bitstream DAC I/O lines to be in Audio Bitstream DAC peripheral mode.

#### 34.5.2 Power Management

The PB-bus clock to the Audio Bitstream DAC is generated by the power manager. Before using the Audio Bitstream DAC, the programmer must ensure that the Audio Bitstream DAC clock is enabled in the power manager.

### 34.5.3 Clock Management

The Audio Bitstream DAC needs a separate clock for the D/A conversion operation. This clock should be set up in the generic clock register in the power manager. The frequency of this clock must be 256 times the frequency of the desired samplerate ( $f_s$ ). For  $f_s=48\text{kHz}$  this means that the clock must have a frequency of 12.288MHz.

### 34.5.4 Interrupts

The Audio Bitstream DAC interface has an interrupt line connected to the interrupt controller. In order to handle interrupts, the interrupt controller must be programmed before configuring the Audio Bitstream DAC.

All Audio Bitstream DAC interrupts can be enabled/disabled by writing to the Audio Bitstream DAC Interrupt Enable/Disable Registers. Each pending and unmasked Audio Bitstream DAC interrupt will assert the interrupt line. The Audio Bitstream DAC interrupt service routine can get the interrupt source by reading the Interrupt Status Register.

### 34.5.5 DMA

The Audio Bitstream DAC is connected to the DMA controller. The DMA controller can be programmed to automatically transfer samples to the Audio Bitstream DAC Sample Data Register (SDR) when the Audio Bitstream DAC is ready for new samples. This enables the Audio Bitstream DAC to operate without any CPU intervention such as polling the Interrupt Status Register (ISR) or using interrupts. See the DMA controller documentation for details on how to setup DMA transfers.

## 34.6 Functional Description

In order to use the Audio Bitstream DAC the product dependencies given in [Section 34.5 on page 722](#) must be resolved. Particular attention should be given to the configuration of clocks and I/O lines in order to ensure correct operation of the Audio Bitstream DAC.

The Audio Bitstream DAC is enabled by writing the ENABLE bit in the Audio Bitstream DAC Control Register (CR). The two 16-bit sample values for channel 0 and 1 can then be written to the least and most significant halfword of the Sample Data Register (SDR), respectively. The TX\_READY bit in the Interrupt Status Register (ISR) will be set whenever the DAC is ready to receive a new sample. A new sample value should be written to SDR before 256 DAC clock cycles, or an underrun will occur, as indicated by the UNDERRUN status flags in ISR. ISR is cleared when read, or when writing one to the corresponding bits in the Interrupt Clear Register (ICR).

For interrupt-based operation, the relevant interrupts must be enabled by writing one to the corresponding bits in the Interrupt Enable Register (IER). Interrupts can be disabled by the Interrupt Disable Register (IDR), and active interrupts are indicated in the read-only Interrupt Mask Register (IMR).

The Audio Bitstream DAC can also be configured for peripheral DMA access, in which case only the enable bit in the control register needs to be set in the Audio Bitstream DAC module.

### 34.6.1 Equalization Filter

The equalization filter is a simple 3-tap FIR filter. The purpose of this filter is to compensate for the pass band frequency response of the sinc interpolation filter. The equalization filter makes the pass band response more flat and moves the -3dB corner a little higher.

### 34.6.2 Interpolation filter

The interpolation filter interpolates from  $f_s$  to  $128f_s$ . This filter is a 4th order Cascaded Integrator-Comb filter, and the basic building blocks of this filter is a comb part and an integrator part.

### 34.6.3 Sigma Delta Modulator

This part is a 3rd order Sigma Delta Modulator consisting of three differentiators (delta blocks), three integrators (sigma blocks) and a one bit quantizer. The purpose of the integrators is to shape the noise, so that the noise is reduced in the band of interest and increased at the higher frequencies, where it can be filtered.

### 34.6.4 Data Format

Input data is on two's complement format.

### 34.7 Audio Bitstream DAC User Interface

Table 34-2. Register Mapping

Offset	Register	Register Name	Access	Reset
0x0	Sample Data Register	SDR	Read/Write	0x0
0x4	Reserved	-	-	-
0x8	Control Register	CR	Read/Write	0x0
0xc	Interrupt Mask Register	IMR	Read	0x0
0x10	Interrupt Enable Register	IER	Write	-
0x14	Interrupt Disable Register	IDR	Write	-
0x18	Interrupt Clear Register	ICR	Write	-
0x1C	Interrupt Status Register	ISR	Read	0x0

## 34.7.1 Audio Bitstream DAC Sample Data Register

**Name:** SDR  
**Access Type:** Read-Write

31	30	29	28	27	26	25	24
CHANNEL1							
23	22	21	20	19	18	17	16
CHANNEL1							
15	14	13	12	11	10	9	8
CHANNEL0							
7	6	5	4	3	2	1	0
CHANNEL0							

- **CHANNEL0: Sample Data for Channel 0**

Signed 16-bit Sample Data for channel 0. When the SWAP bit in the DAC Control Register (CR) is set writing to the Sample Data Register (SDR) will cause the values written to CHANNEL0 and CHANNEL1 to be swapped.

- **CHANNEL1: Sample Data for Channel 1**

Signed 16-bit Sample Data for channel 1. When the SWAP bit in the DAC Control Register (CR) is set writing to the Sample Data Register (SDR) will cause the values written to CHANNEL0 and CHANNEL1 to be swapped.

## 34.7.2 Audio Bitstream DAC Control Register

**Name:** CR  
**Access Type:** Read-Write

31	30	29	28	27	26	25	24
EN	SWAP	-	-	-	-	-	-
23	22	21	20	19	18	17	16
-	-	-	-	-	-	-	-
15	14	13	12	11	10	9	8
-	-	-	-	-	-	-	-
7	6	5	4	3	2	1	0
-	-	-	-	-	-	-	-

- **SWAP: Swap Channels**

0: The CHANNEL0 and CHANNEL1 samples will not be swapped when writing the Audio Bitstream DAC Sample Data Register (SDR).

1: The CHANNEL0 and CHANNEL1 samples will be swapped when writing the Audio Bitstream DAC Sample Data Register (SDR).

- **EN: Enable Audio Bitstream DAC**

0: Audio Bitstream DAC is disabled.

1: Audio Bitstream DAC is enabled.

### 34.7.3 Audio Bitstream DAC Interrupt Mask Register

**Name:** IMR  
**Access Type:** Read-only

31	30	29	28	27	26	25	24
-	-	TX_READY	UNDERRUN	-	-	-	-
23	22	21	20	19	18	17	16
-	-	-	-	-	-	-	-
15	14	13	12	11	10	9	8
-	-	-	-	-	-	-	-
7	6	5	4	3	2	1	0
-	-	-	-	-	-	-	-

- **UNDERRUN: Underrun Interrupt Mask**

0: The Audio Bitstream DAC Underrun interrupt is disabled.

1: The Audio Bitstream DAC Underrun interrupt is enabled.

- **TX\_READY: TX Ready Interrupt Mask**

0: The Audio Bitstream DAC TX Ready interrupt is disabled.

1: The Audio Bitstream DAC TX Ready interrupt is enabled.



## 34.7.4 Audio Bitstream DAC Interrupt Enable Register

**Name:** IER  
**Access Type:** Write-only

31	30	29	28	27	26	25	24
-	-	TX_READY	UNDERRUN	-	-	-	-
23	22	21	20	19	18	17	16
-	-	-	-	-	-	-	-
15	14	13	12	11	10	9	8
-	-	-	-	-	-	-	-
7	6	5	4	3	2	1	0
-	-	-	-	-	-	-	-

- **UNDERRUN: Underrun Interrupt Enable**

0: No effect.

1: Enables the Audio Bitstream DAC Underrun interrupt.

- **TX\_READY: TX Ready Interrupt Enable**

0: No effect.

1: Enables the Audio Bitstream DAC TX Ready interrupt.

## 34.7.5 Audio Bitstream DAC Interrupt Disable Register

**Name:** IDR  
**Access Type:** Write-only

31	30	29	28	27	26	25	24
-	-	TX_READY	UNDERRUN	-	-	-	-
23	22	21	20	19	18	17	16
-	-	-	-	-	-	-	-
15	14	13	12	11	10	9	8
-	-	-	-	-	-	-	-
7	6	5	4	3	2	1	0
-	-	-	-	-	-	-	-

- **UNDERRUN: Underrun Interrupt Disable**

0: No effect.

1: Disable the Audio Bitstream DAC Underrun interrupt.

- **TX\_READY: TX Ready Interrupt Disable**

0: No effect.

1: Disable the Audio Bitstream DAC TX Ready interrupt.

## 34.7.6 Audio Bitstream DAC Interrupt Clear Register

**Name:** ICR  
**Access Type:** Write-only

31	30	29	28	27	26	25	24
-	-	TX_READY	UNDERRUN	-	-	-	-
23	22	21	20	19	18	17	16
-	-	-	-	-	-	-	-
15	14	13	12	11	10	9	8
-	-	-	-	-	-	-	-
7	6	5	4	3	2	1	0
-	-	-	-	-	-	-	-

- **UNDERRUN: Underrun Interrupt Clear**

0: No effect.

1: Clear the Audio Bitstream DAC Underrun interrupt.

- **TX\_READY: TX Ready Interrupt Clear**

0: No effect.

1: Clear the Audio Bitstream DAC TX Ready interrupt.

## 34.7.7 Audio Bitstream DAC Interrupt Status Register

**Name:** ISR  
**Access Type:** Read-only

31	30	29	28	27	26	25	24
-	-	TX_READY	UNDERRUN	-	-	-	-
23	22	21	20	19	18	17	16
-	-	-	-	-	-	-	-
15	14	13	12	11	10	9	8
-	-	-	-	-	-	-	-
7	6	5	4	3	2	1	0
-	-	-	-	-	-	-	-

- **UNDERRUN: Underrun Interrupt Status**

0: No Audio Bitstream DAC Underrun has occurred since the last time ISR was read or since reset.

1: At least one Audio Bitstream DAC Underrun has occurred since the last time ISR was read or since reset.

- **TX\_READY: TX Ready Interrupt Status**

0: No Audio Bitstream DAC TX Ready has occurred since the last time ISR was read.

1: At least one Audio Bitstream DAC TX Ready has occurred since the last time ISR was read.

## 34.8 Frequency Response

Figure 34-2. Frequency response, EQ-FIR+COMB<sup>4</sup>

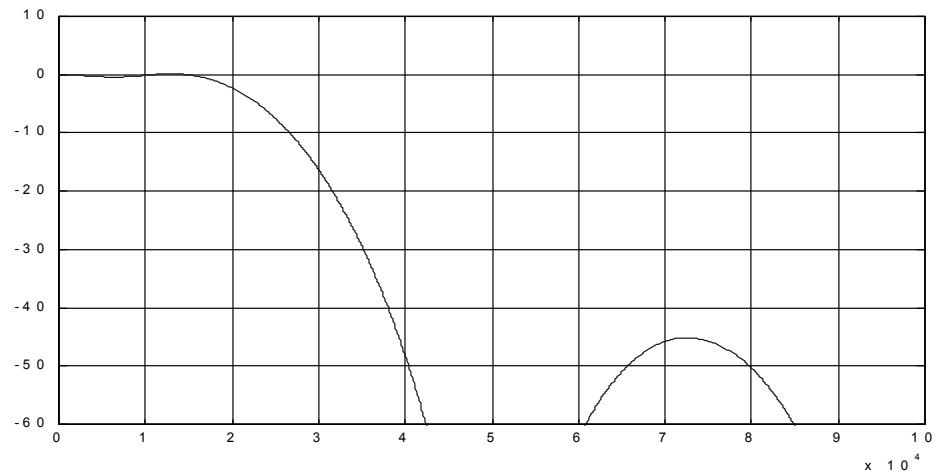

## 35. On-Chip Debug

Rev: 1.3.0.0

### 35.1 Features

- Debug interface in compliance with IEEE-ISTO 5001-2003 (Nexus 2.0) Class 2+
- JTAG access to all on-chip debug functions
- Advanced Program, Data, Ownership, and Watchpoint trace supported
- NanoTrace JTAG-based trace access
- Auxiliary port for high-speed trace information
- Hardware support for 6 Program and 2 Data breakpoints
- Unlimited number of software breakpoints supported
- Automatic CRC check of memory regions

### 35.2 Overview

Debugging on the AT32UC3A is facilitated by a powerful On-Chip Debug (OCD) system. The user accesses this through an external debug tool which connects to the JTAG port and the Auxiliary (AUX) port. The AUX port is primarily used for trace functions, and a JTAG-based debugger is sufficient for basic debugging.

The debug system is based on the Nexus 2.0 standard, class 2+, which includes:

- Basic run-time control
- Program breakpoints
- Data breakpoints
- Program trace
- Ownership trace
- Data trace

In addition to the mandatory Nexus debug features, the AT32UC3A implements several useful OCD features, such as:

- Debug Communication Channel between CPU and JTAG
- Run-time PC monitoring
- CRC checking
- NanoTrace
- Software Quality Assurance (SQA) support

The OCD features are controlled by OCD registers, which can be accessed by JTAG when the NEXUS\_ACCESS JTAG instruction is loaded. The CPU can also access OCD registers directly using mtdr/mfdr instructions in any privileged mode. The OCD registers are implemented based on the recommendations in the Nexus 2.0 standard, and are detailed in the AVR32UC Technical Reference Manual.

### 35.3 Block diagram

Figure 35-1. On-Chip Debug block diagram

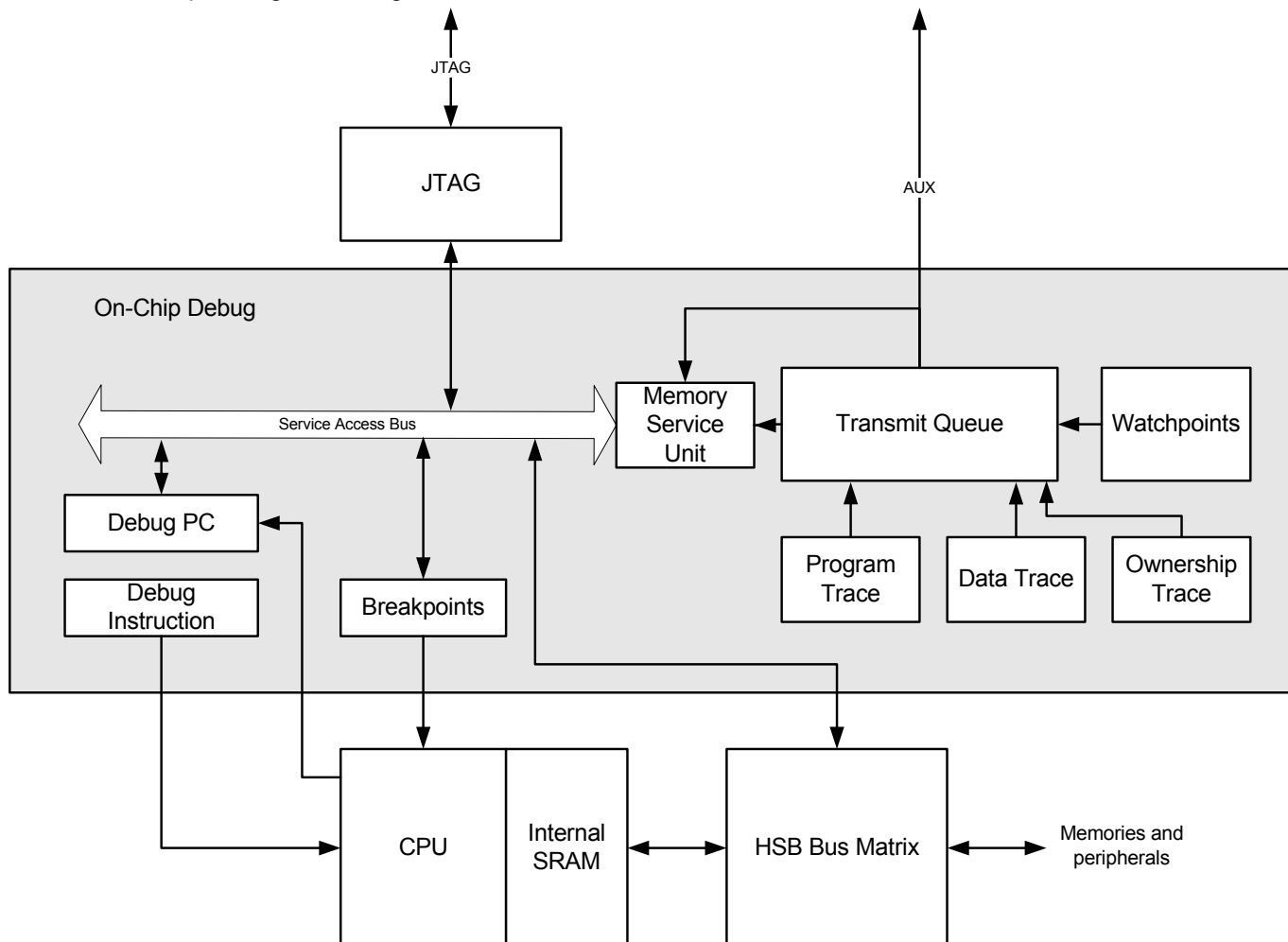

### 35.4 Functional description

#### 35.4.1 JTAG-based debug features

A debugger can control all OCD features by writing OCD registers over the JTAG interface. Many of these do not depend on output on the AUX port, allowing a JTAG-based debugger to be used.

A JTAG-based debugger should connect to the device through a standard 10-pin IDC connector as described in the AVR32UC Technical Reference Manual.

Figure 35-2. JTAG-based debugger

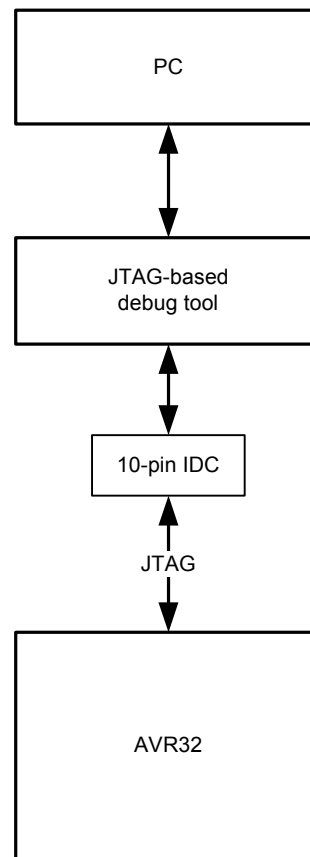

#### 35.4.1.1 Debug Communication Channel

The Debug Communication Channel (DCC) consists of a pair of OCD registers with associated handshake logic, accessible to both CPU and JTAG. The registers can be used to exchange data between the CPU and the JTAG master, both runtime as well as in debug mode.

#### 35.4.1.2 Breakpoints

One of the most fundamental debug features is the ability to halt the CPU, to examine registers and the state of the system. This is accomplished by breakpoints, of which many types are available:

- Unconditional breakpoints are set by writing OCD registers by JTAG, halting the CPU immediately.
- Program breakpoints halt the CPU when a specific address in the program is executed.
- Data breakpoints halt the CPU when a specific memory address is read or written, allowing variables to be watched.
- Software breakpoints halt the CPU when the breakpoint instruction is executed.

When a breakpoint triggers, the CPU enters debug mode, and the D bit in the status register is set. This is a privileged mode with dedicated return address and return status registers. All privileged instructions are permitted. Debug mode can be entered as either OCD Mode, running instructions from JTAG, or Monitor Mode, running instructions from program memory.



### 35.4.1.3 *OCD Mode*

When a breakpoint triggers, the CPU enters OCD mode, and instructions are fetched from the Debug Instruction OCD register. Each time this register is written by JTAG, the instruction is executed, allowing the JTAG to execute CPU instructions directly. The JTAG master can e.g. read out the register file by issuing mtdr instructions to the CPU, writing each register to the Debug Communication Channel OCD registers.

### 35.4.1.4 *Monitor Mode*

Since the OCD registers are directly accessible by the CPU, it is possible to build a software-based debugger that runs on the CPU itself. Setting the Monitor Mode bit in the Development Control register causes the CPU to enter Monitor Mode instead of OCD mode when a breakpoint triggers. Monitor Mode is similar to OCD mode, except that instructions are fetched from the debug exception vector in regular program memory, instead of issued by JTAG.

### 35.4.1.5 *Program Counter monitoring*

Normally, the CPU would need to be halted for a JTAG-based debugger to examine the current PC value. However, the AT32UC3A also provides a Debug Program Counter OCD register, where the debugger can continuously read the current PC without affecting the CPU. This allows the debugger to generate a simple statistic of the time spent in various areas of the code, easing code optimization.

## 35.4.2 **Memory Service Unit**

The Memory Service Unit (MSU) is a block dedicated to test and debug functionality. It is controlled through a dedicated set of registers addressed through the MEMORY\_SERVICE JTAG command.

### 35.4.2.1 *Cyclic Redundancy Check (CRC)*

The MSU can be used to automatically calculate the CRC of a block of data in memory. The OCD will then read out each word in the specified memory block and report the CRC32-value in an OCD register.

### 35.4.2.2 *NanoTrace*

The MSU additionally supports NanoTrace. This is an AVR32-specific feature, in which trace data is output to memory instead of the AUX port. This allows the trace data to be extracted by JTAG MEMORY\_ACCESS, enabling trace features for JTAG-based debuggers. The user must write MSU registers to configure the address and size of the memory block to be used for NanoTrace. The NanoTrace buffer can be anywhere in the physical address range, including internal and external RAM, through an EBI, if present. This area may not be used by the application running on the CPU.

## 35.4.3 **AUX-based debug features**

Utilizing the Auxiliary (AUX) port gives access to a wide range of advanced debug features. Of prime importance are the trace features, which allow an external debugger to receive continuous information on the program execution in the CPU. Additionally, Event In and Event Out pins allow external events to be correlated with the program flow.

The AUX port contains a number of pins, as shown in [Table 35-1 on page 738](#). These are multiplexed with PIO lines, and must explicitly be enabled by writing OCD registers before the debug session starts. The AUX port is mapped to two different locations, selectable by OCD Registers, minimizing the chance that the AUX port will need to be shared with an application.

Debug tools utilizing the AUX port should connect to the device through a Nexus-compliant Micror-38 connector, as described in the AVR32UC Technical Reference manual. This connector includes the JTAG signals and the RESET\_N pin, giving full access to the programming and debug features in the device.

**Table 35-1.** Auxiliary port signals

Signal	Direction	Description
MCKO	Output	Trace data output clock
MDO[5:0]	Output	Trace data output
MSEO[1:0]	Output	Trace frame control
EVTI_N	Input	Event In
EVTO_N	Output	Event Out

**Figure 35-3.** AUX+JTAG based debugger

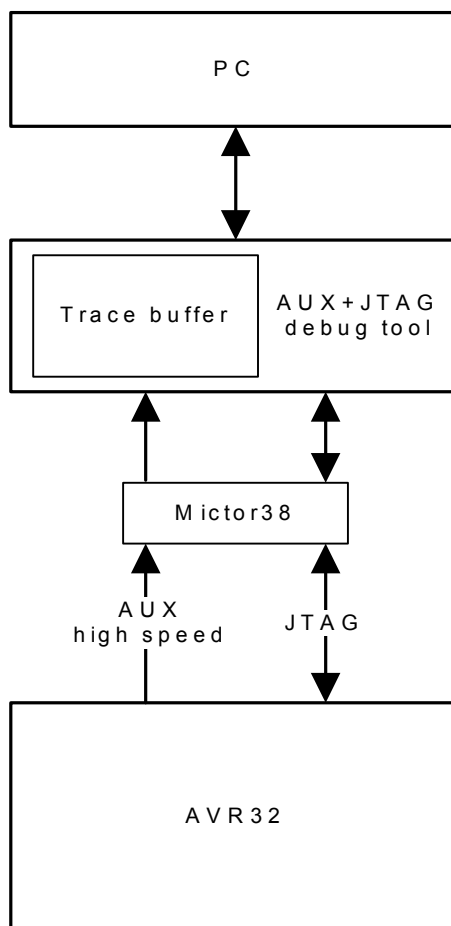

### 35.4.3.1 Trace operation

Trace features are enabled by writing OCD registers by JTAG. The OCD extracts the trace information from the CPU, compresses this information and formats it into variable-length messages according to the Nexus standard. The messages are buffered in a 16-frame transmit queue, and are output on the AUX port one frame at a time.

The trace features can be configured to be very selective, to reduce the bandwidth on the AUX port. In case the transmit queue overflows, error messages are produced to indicate loss of data. The transmit queue module can optionally be configured to halt the CPU when an overflow occurs, to prevent the loss of messages, at the expense of longer run-time for the program.

#### 35.4.3.2 *Program Trace*

Program trace allows the debugger to continuously monitor the program execution in the CPU. Program trace messages are generated for every branch in the program, and contains compressed information, which allows the debugger to correlate the message with the source code to identify the branch instruction and target address.

#### 35.4.3.3 *Data Trace*

Data trace outputs a message every time a specific location is read or written. The message contains information about the type (read/write) and size of the access, as well as the address and data of the accessed location. The AT32UC3A contains two data trace channels, each of which are controlled by a pair of OCD registers which determine the range of addresses (or single address) which should produce data trace messages.

#### 35.4.3.4 *Ownership Trace*

Program and data trace operate on virtual addresses. In cases where an operating system runs several processes in overlapping virtual memory segments, the Ownership Trace feature can be used to identify the process switch. When the O/S activates a process, it will write the process ID number to an OCD register, which produces an Ownership Trace Message, allowing the debugger to switch context for the subsequent program and data trace messages. As the use of this feature depends on the software running on the CPU, it can also be used to extract other types of information from the system.

#### 35.4.3.5 *Watchpoint messages*

The breakpoint modules normally used to generate program and data breakpoints can also be used to generate Watchpoint messages, allowing a debugger to monitor program and data events without halting the CPU. Watchpoints can be enabled independently of breakpoints, so a breakpoint module can optionally halt the CPU when the trigger condition occurs. Data trace modules can also be configured to produce watchpoint messages instead of regular data trace messages.

#### 35.4.3.6 *Event In and Event Out pins*

The AUX port also contains an Event In pin (EVTI\_N) and an Event Out pin (EVTO\_N). EVTI\_N can be used to trigger a breakpoint when an external event occurs. It can also be used to trigger specific program and data trace synchronization messages, allowing an external event to be correlated to the program flow.

When the CPU enters debug mode, a Debug Status message is transmitted on the trace port. All trace messages can be timestamped when they are received by the debug tool. However, due to the latency of the transmit queue buffering, the timestamp will not be 100% accurate. To improve this, EVTO\_N can toggle every time a message is inserted into the transmit queue, allowing trace messages to be timestamped precisely. EVTO\_N can also toggle when a breakpoint module triggers, or when the CPU enters debug mode, for any reason. This can be used to measure precisely when the respective internal event occurs.

#### 35.4.3.7 Software Quality Analysis (SQA)

Software Quality Analysis (SQA) deals with two important issues regarding embedded software development. *Code coverage* involves identifying untested parts of the embedded code, to improve test procedures and thus the quality of the released software. *Performance analysis* allows the developer to precisely quantify the time spent in various parts of the code, allowing bottlenecks to be identified and optimized.

Program trace must be used to accomplish these tasks without instrumenting (altering) the code to be examined. However, traditional program trace cannot reconstruct the current PC value without correlating the trace information with the source code, which cannot be done on-the-fly. This limits program trace to a relatively short time segment, determined by the size of the trace buffer in the debug tool.

The OCD system in AT32UC3A extends program trace with SQA capabilities, allowing the debug tool to reconstruct the PC value on-the-fly. Code coverage and performance analysis can thus be reported for an unlimited execution sequence.

## 36. JTAG and Boundary Scan

Rev.: 2.0.0.2

### 36.1 Features

- IEEE1149.1 compliant JTAG Interface
- Boundary-Scan Chain for board-level testing
- Direct memory access and programming capabilities through JTAG interface
- On-Chip Debug access in compliance with IEEE-ISTO 5001-2003 (Nexus 2.0)

### 36.2 Overview

[Figure 36-1 on page 742](#) shows how the JTAG is connected in an AVR32 device. The TAP Controller is a state machine controlled by the TCK and TMS signals. The TAP Controller selects either the JTAG Instruction Register or one of several Data Registers as the scan chain (shift register) between the TDI-input and TDO-output. The Instruction Register holds JTAG instructions controlling the behavior of a Data Register.

The ID Register, Bypass Register, and the Boundary-Scan Chain are the Data Registers used for board-level testing. The Reset Register can be used to keep the device reset during test or programming.

The Service Access Bus (SAB) interface contains address and data registers for the Service Access Bus, which gives access to on-chip debug, programming, and other functions in the device. The SAB offers several modes of access to the address and data registers, as discussed in [Section 36.6.4](#).

[Section 36.7](#) lists the supported JTAG instructions, with references to the description in this document.

### 36.3 Block diagram

Figure 36-1. JTAG and Boundary Scan access

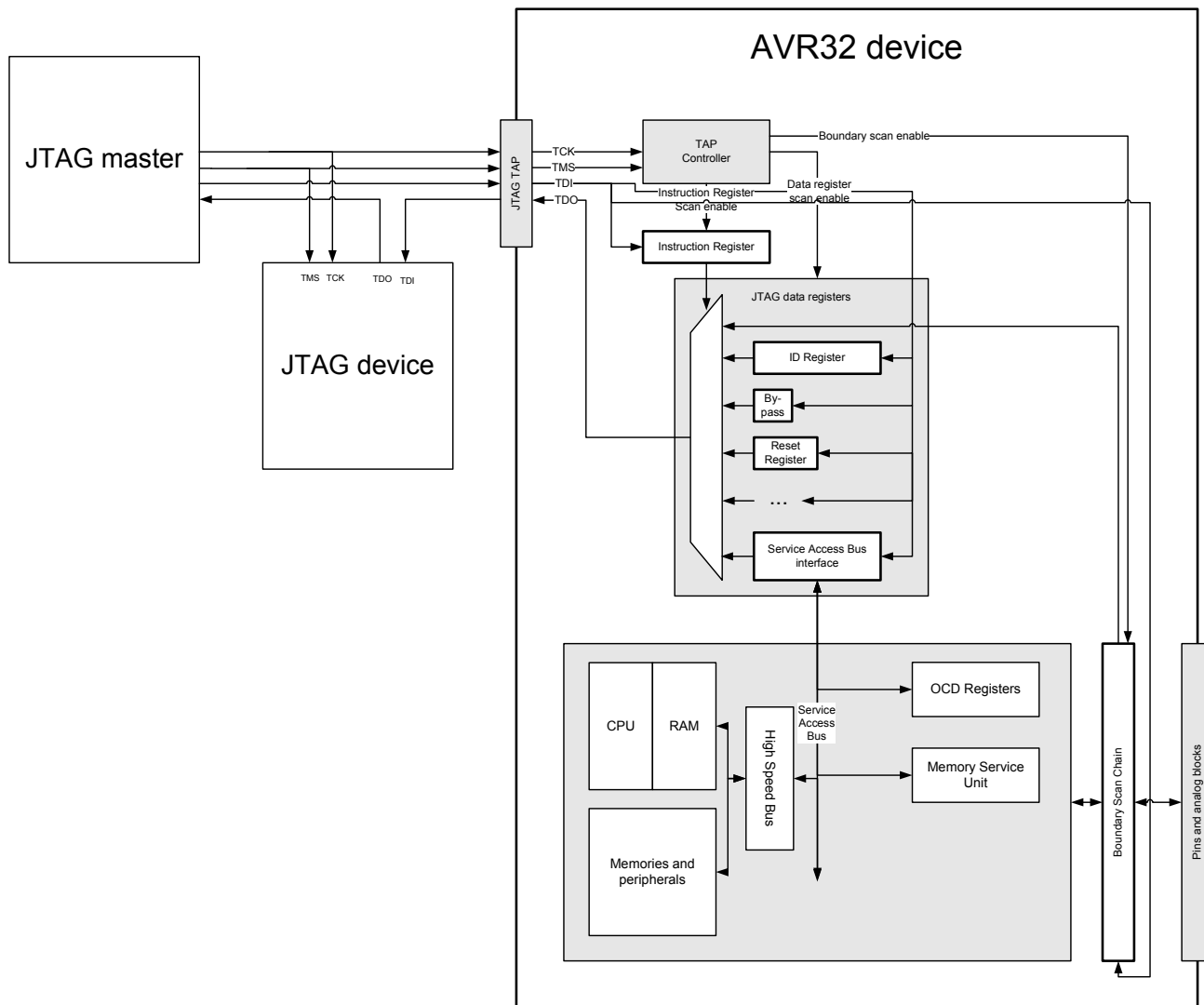

## 36.4 I/O Lines Description

Table 36-1. I/O Lines Description

Name	Description	Type
TCK	Test Clock Input. Fully asynchronous to system clock frequency.	Input
TMS	Test Mode Select, sampled on rising TCK	Input
TDI	Test Data In, sampled on rising TCK.	Input
TDO	Test Data Out, driven on falling TCK.	Output

## 36.5 Product Dependencies

In order to use this module, other parts of the system must be configured correctly, as described below.

### 36.5.1 I/O Lines

The JTAG interface pins are multiplexed with IO lines. When the JTAG is used the associated pins must be enabled. To enable the JTAG pins TCK must be zero while RESET\_N has a zero to one transition. To disable the JTAG pins TCK must be one while RESET\_N has a zero to one transition.

While using the JTAG lines all normal peripheral activity on these lines are disabled. The user must make sure that no external peripheral is blocking the JTAG lines while debugging.

## 36.6 Functional description

### 36.6.1 JTAG interface

The JTAG interface is accessed through the dedicated JTAG pins shown in [Table 36-1 on page 743](#). The TMS control line navigates the TAP controller, as shown in [Figure 36-2 on page 744](#). The TAP controller manages the serial access to the JTAG Instruction and Data registers. Data is scanned into the selected instruction or data register on TDI, and out of the register on TDO, in the Shift-IR and Shift-DR states, respectively. The LSB is shifted in and out first. TDO is high-Z in other states than Shift-IR and Shift-DR.

Independent of the initial state of the TAP Controller, the Test-Logic-Reset state can always be entered by holding TMS high for 5 TCK clock periods. This sequence should always be applied at the start of a JTAG session to bring the TAP Controller into a defined state before applying JTAG commands. Applying a 0 on TMS for 1 TCK period brings the TAP Controller to the Run-Test/Idle state, which is the starting point for JTAG operations.

The device implements a 5-bit Instruction Register (IR). A number of public JTAG instructions defined by the JTAG standard are supported, as described in [Section 36.8](#), as well as a number of AVR32-specific private JTAG instructions described in [Section 36.9](#). Each instruction selects a specific data register for the Shift-DR path, as described for each instruction.

Figure 36-2. TAP Controller State Diagram

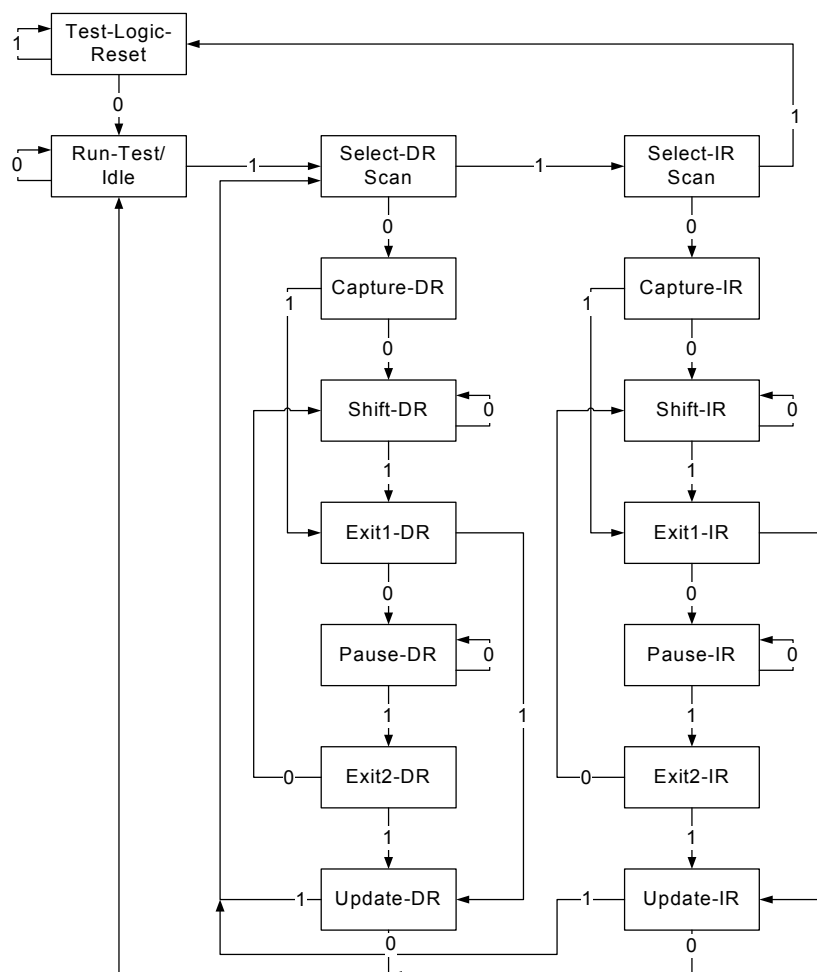

### 36.6.2 Typical sequence

Assuming Run-Test/Idle is the present state, a typical scenario for using the JTAG interface is:

#### 36.6.2.1 Scanning in JTAG instruction

At the TMS input, apply the sequence 1, 1, 0, 0 at the rising edges of TCK to enter the Shift Instruction Register - Shift-IR state. While in this state, shift the 5 bits of the JTAG instructions into the JTAG instruction register from the TDI input at the rising edge of TCK. The TMS input must be held low during input of the 4 LSBs in order to remain in the Shift-IR state. The JTAG Instruction selects a particular Data Register as path between TDI and TDO and controls the circuitry surrounding the selected Data Register.

Apply the TMS sequence 1, 1, 0 to re-enter the Run-Test/Idle state. The instruction is latched onto the parallel output from the shift register path in the Update-IR state. The Exit-IR, Pause-IR, and Exit2-IR states are only used for navigating the state machine.



Figure 36-3. Scanning in JTAG instruction

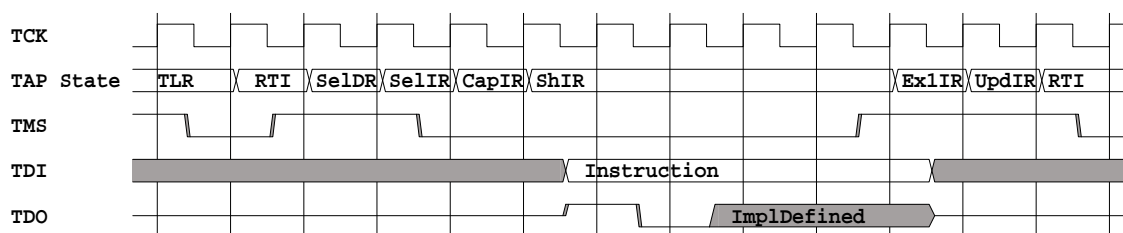

### 36.6.2.2 Scanning in/out data

At the TMS input, apply the sequence 1, 0, 0 at the rising edges of TCK to enter the Shift Data Register - Shift-DR state. While in this state, upload the selected Data Register (selected by the present JTAG instruction in the JTAG Instruction Register) from the TDI input at the rising edge of TCK. In order to remain in the Shift-DR state, the TMS input must be held low. While the Data Register is shifted in from the TDI pin, the parallel inputs to the Data Register captured in the Capture-DR state is shifted out on the TDO pin.

Apply the TMS sequence 1, 1, 0 to re-enter the Run-Test/Idle state. If the selected Data Register has a latched parallel-output, the latching takes place in the Update-DR state. The Exit-DR, Pause-DR, and Exit2-DR states are only used for navigating the state machine.

As shown in the state diagram, the Run-Test/Idle state need not be entered between selecting JTAG instruction and using Data Registers.

### 36.6.3 Boundary-Scan

The Boundary-Scan chain has the capability of driving and observing the logic levels on the digital I/O pins, as well as the boundary between digital and analog logic for analog circuitry having off-chip connections. At system level, all ICs having JTAG capabilities are connected serially by the TDI/TDO signals to form a long shift register. An external controller sets up the devices to drive values at their output pins, and observe the input values received from other devices. The controller compares the received data with the expected result. In this way, Boundary-Scan provides a mechanism for testing interconnections and integrity of components on Printed Circuits Boards by using the 4 TAP signals only.

The four IEEE 1149.1 defined mandatory JTAG instructions IDCODE, BYPASS, SAMPLE/PRELOAD, and EXTEST can be used for testing the Printed Circuit Board. Initial scanning of the data register path will show the ID-code of the device, since IDCODE is the default JTAG instruction. It may be desirable to have the AVR32 device in reset during test mode. If not reset, inputs to the device may be determined by the scan operations, and the internal software may be in an undetermined state when exiting the test mode. Entering reset, the outputs of any Port Pin will instantly enter the high impedance state, making the HIGHZ instruction redundant. If needed, the BYPASS instruction can be issued to make the shortest possible scan chain through the device. The device can be set in the reset state either by pulling the external RESETn pin low, or issuing the AVR\_RESET instruction with appropriate setting of the Reset Data Register.

The EXTEST instruction is used for sampling external pins and loading output pins with data. The data from the output latch will be driven out on the pins as soon as the EXTEST instruction is loaded into the JTAG IR-register. Therefore, the SAMPLE/PRELOAD should also be used for setting initial values to the scan ring, to avoid damaging the board when issuing the EXTEST

instruction for the first time. SAMPLE/PRELOAD can also be used for taking a snapshot of the external pins during normal operation of the part.

When using the JTAG interface for Boundary-Scan, the JTAG TCK clock is independent of the internal chip clock, which is not required to run.

### 36.6.4 Service Access Bus

A number of private instructions are used to access Service Access Bus (SAB) resources. Each of these are described in detail in SAB address map in the Service Access Bus chapter. The MEMORY\_SIZED\_ACCESS instruction allows a sized read or write to any 36-bit address on the bus. MEMORY\_WORD\_ACCESS is a shorthand instruction for 32-bit accesses to any 36-bit address, while the NEXUS\_ACCESS instruction is a Nexus-compliant shorthand instruction for accessing the 32-bit OCD registers in the 7-bit address space reserved for these. These instructions require two passes through the Shift-DR TAP state: one for the address and control information, and one for data.

To increase the transfer rate, consecutive memory accesses can be accomplished by the MEMORY\_BLOCK\_ACCESS instruction, which only requires a single pass through Shift-DR for data transfer only. The address is automatically incremented according to the size of the last SAB transfer.

The access time to SAB resources depends on the type of resource being accessed. It is possible to read external memory through the EBI, in which case the latency may be very long. It is possible to abort an ongoing SAB access by the CANCEL\_ACCESS instruction, to avoid hanging the bus due to an extremely slow slave.

"The access time to SAB resources depends on the type of resource being accessed. It is possible to abort an ongoing SAB access by the CANCEL\_ACCESS instruction, to avoid hanging the bus due to an extremely slow slave."

#### 36.6.4.1 Busy reporting

As the time taken to perform an access may vary depending on system activity and current chip frequency, all the SAB access JTAG instructions can return a busy indicator. This indicates whether a delay needs to be inserted, or an operation needs to be repeated in order to be successful. If a new access is requested while the SAB is busy, the request is ignored.

The SAB becomes busy when:

- Entering Update-DR in the address phase of any read operation, e.g. after scanning in a NEXUS\_ACCESS address with the read bit set.
- Entering Update-DR in the data phase of any write operation, e.g. after scanning in data for a NEXUS\_ACCESS write.
- Entering Update-DR during a MEMORY\_BLOCK\_ACCESS.
- Entering Update-DR after scanning in a counter value for SYNC.
- Entering Update-IR after scanning in a MEMORY\_BLOCK\_ACCESS if the previous access was a read and data was scanned after scanning the address.

The SAB becomes ready again when:

- A read or write operation completes.



- A SYNC countdown completed.
- A operation is cancelled by the CANCEL\_ACCESS instruction.

What to do if the busy bit is set:

- During Shift-IR: The new instruction is selected, but the previous operation has not yet completed and will continue (unless the new instruction is CANCEL\_ACCESS). You may continue shifting the same instruction until the busy bit clears, or start shifting data. If shifting data, you must be prepared that the data shift may also report busy.
- During Shift-DR of an address: The new address is ignored. The SAB stays in address mode, so no data must be shifted. Repeat the address until the busy bit clears.
- During Shift-DR of read data: The read data are invalid. The SAB stays in data mode. Repeat scanning until the busy bit clears.
- During Shift-DR of write data: The write data are ignored. The SAB stays in data mode. Repeat scanning until the busy bit clears.

#### 36.6.4.2 Error reporting

The Service access port may not be able to complete all accesses as requested. This may be because the address is invalid, the addressed area is read-only or cannot handle byte/halfword accesses, or because the chip is set in a protected mode where only limited accesses are allowed.

The error bit is updated when an access completes, and is cleared when a new access starts.

What to do if the error bit is set:

- During Shift-IR: The new instruction is selected. The last operation performed using the old instruction did not complete successfully.
- During Shift-DR of an address: The previous operation failed. The new address is accepted. If the read bit is set, a read operation is started.
- During Shift-DR of read data: The read operation failed, and the read data are invalid.
- During Shift-DR of write data: The previous write operation failed. The new data are accepted and a write operation started. This should only occur during block writes or stream writes. No error can occur between scanning a write address and the following write data.
- While polling with CANCEL\_ACCESS: The previous access was cancelled. It may or may not have actually completed.

#### 36.6.5 Memory programming

The High-Speed Bus (HSB) in the device is mapped as a slave on the SAB. This enables all HSB-mapped memories to be read or written through the SAB using JTAG instructions, as described in [Section 36.6.4](#).

Internal SRAM can always be directly accessed. External static memory or SDRAM can be accessed if the EBI has been correctly configured to access this memory. It is also possible to access the configuration registers for these modules to set up the correct configuration. Similarly, external parallel flash can be programmed by accessing the registers for the flash device through the EBI.

The internal flash and fuses can likewise be programmed by accessing the registers in the Flash Controller. When the security fuse is set, access to internal memory is blocked, and the CHIP\_ERASE instruction must be used to erase the fuse and flash contents. For detail see the SAB address map section.



Memory can be written while the CPU is executing, which can be utilized for debug purposes. When downloading a new program, the JTAG HALT instruction should be used to freeze the CPU, to prevent partially downloaded code from being executed.

## 36.7 JTAG Instruction Summary

The implemented JTAG instructions in the AVR32 are shown in the table below.

**Table 36-2.** JTAG Instruction Summary

Instruction OPCODE	Instruction	Description	Page
0x01	IDCODE	Select the 32-bit ID register as data register.	749
0x02	SAMPLE_PRELOAD	Take a snapshot of external pin values without affecting system operation.	749
0x03	EXTEST	Select boundary scan chain as data register for testing circuitry external to the device.	749
0x04	INTEST	Select boundary scan chain for internal testing of the device.	749
0x06	CLAMP	Bypass device through Bypass register, while driving outputs from boundary scan register.	750
0x0C	AVR_RESET	Apply or remove a static reset to the device	757
0x0F	CHIP_ERASE	Erase the device	757
0x10	NEXUS_ACCESS	Select the SAB Address and Data registers as data register for the TAP. The registers are accessed in Nexus mode.	751
0x11	MEMORY_WORD_ACCESS	Select the SAB Address and Data registers as data register for the TAP.	754
0x12	MEMORY_BLOCK_ACCESS	Select the SAB Data register as data register for the TAP. The address is auto-incremented.	755
0x13	CANCEL_ACCESS	Cancel an ongoing Nexus or Memory access.	756
0x14	MEMORY_SERVICE	Select the SAB Address and Data registers as data register for the TAP. The registers are accessed in Memory Service mode.	752
0x15	MEMORY_SIZED_ACCESS	Select the SAB Address and Data registers as data register for the TAP.	753
0x17	SYNC	Synchronization counter	757
0x1C	HALT	Halt the CPU for safe programming.	758
0x1F	BYPASS	Bypass this device through the bypass register.	750
Others	N/A	Acts as BYPASS	

### 36.7.1 Security restrictions

When the security fuse in the Flash is programmed, the following JTAG instructions are restricted:

- NEXUS\_ACCESS
- MEMORY\_WORD\_ACCESS
- MEMORY\_BLOCK\_ACCESS
- MEMORY\_SIZED\_ACCESS

For description of what memory locations remain accessible, please refer to the SAB address map.

Full access to these instructions is re-enabled when the security fuse is erased by the CHIP\_ERASE JTAG instruction.

Note that the security bit will read as programmed and block these instructions also if the Flash Controller is statically reset.

Other security mechanisms can also restrict these functions. If such mechanisms are present they are listed in the SAB address map section.

## 36.8 Public JTAG instructions

### 36.8.1 IDCODE

This instruction selects the 32 bit ID register as Data Register. The ID register consists of a version number, a device number and the manufacturer code chosen by JEDEC. This is the default instruction after power-up.

The active states are:

- Capture-DR: The static IDCODE value is latched into the shift register.
- Shift-DR: The IDCODE scan chain is shifted by the TCK input.

### 36.8.2 SAMPLE\_PRELOAD

JTAG instruction for taking a snap-shot of the input/output pins without affecting the system operation, and pre-loading the scan chain without updating the DR-latch. The Boundary-Scan Chain is selected as Data Register.

The active states are:

- Capture-DR: Data on the external pins are sampled into the Boundary-Scan Chain.
- Shift-DR: The Boundary-Scan Chain is shifted by the TCK input.

### 36.8.3 EXTEST

JTAG instruction for selecting the Boundary-Scan Chain as Data Register for testing circuitry external to the AVR32 package. The contents of the latched outputs of the Boundary-Scan chain is driven out as soon as the JTAG IR-register is loaded with the EXTEST instruction.

The active states are:

- Capture-DR: Data on the external pins is sampled into the Boundary-Scan Chain.
- Shift-DR: The Internal Scan Chain is shifted by the TCK input.
- Update-DR: Data from the scan chain is applied to output pins.

### 36.8.4 INTEST

This instruction selects the Boundary-Scan Chain as Data Register for testing internal logic in the device. The logic inputs are determined by the Boundary-Scan Chain, and the logic outputs are captured by the Boundary-Scan chain. The device output pins are driven from the Boundary-Scan Chain.

The active states are:

- Capture-DR: Data from the internal logic is sampled into the Boundary-Scan Chain.

- Shift-DR: The Internal Scan Chain is shifted by the TCK input.
- Update-DR: Data from the scan chain is applied to internal logic inputs.

## 36.8.5 CLAMP

This instruction selects the Bypass register as Data Register. The device output pins are driven from the Boundary-Scan Chain.

The active states are:

- Capture-DR: Loads a logic '0' into the Bypass Register.
- Shift-DR: Data is scanned from TDI to TDO through the Bypass register.

## 36.8.6 BYPASS

JTAG instruction selecting the 1-bit Bypass Register for Data Register.

The active states are:

- Capture-DR: Loads a logic '0' into the Bypass Register.
- Shift-DR: Data is scanned from TDI to TDO through the Bypass register.

## 36.9 Private JTAG Instructions

### 36.9.1 Notation

The AVR32 defines a number of private JTAG instructions. Each instruction is briefly described in text, with details following in table form.

[Table 36-4 on page 751](#) shows bit patterns to be shifted in a format like "**peb01**". Each character corresponds to one bit, and eight bits are grouped together for readability. The rightmost bit is always shifted first, and the leftmost bit shifted last. The symbols used are shown in [Table 36-3](#).

**Table 36-3.** Symbol description

Symbol	Description
0	Constant low value - always reads as zero.
1	Constant high value - always reads as one.
a	An address bit - always scanned with the least significant bit first
b	A busy bit. Reads as one if the SAB was busy, or zero if it was not. See <a href="#">Section 36.6.4.1</a> for details on how the busy reporting works.
d	A data bit - always scanned with the least significant bit first.
e	An error bit. Reads as one if an error occurred, or zero if not. See <a href="#">Section 36.6.4.2</a> for details on how the error reporting works.
p	The chip protected bit. Some devices may be set in a protected state where access to chip internals are severely restricted. See the documentation for the specific device for details. On devices without this possibility, this bit always reads as zero.
r	A direction bit. Set to one to request a read, set to zero to request a write.
s	A size bit. The size encoding is described where used.
x	A don't care bit. Any value can be shifted in, and output data should be ignored.

In many cases, it is not required to shift all bits through the data register. Bit patterns are shown using the full width of the shift register, but the suggested or required bits are emphasized using

**bold** text. I.e. given the pattern "**aaaaaar** xxxxxxxx xxxxxxxx xxxxxxxx xx", the shift register is 34 bits, but the test or debug unit may choose to shift only 8 bits "**aaaaaar**".

The following describes how to interpret the fields in the instruction description tables:

**Table 36-4.** Instruction description

Instruction	Description
IR input value	Shows the bit pattern to shift into IR in the Shift-IR state in order to select this instruction. The pattern is show both in binary and in hexadecimal form for convenience. Example: <b>10000</b> (0x10)
IR output value	Shows the bit pattern shifted out of IR in the Shift-IR state when this instruction is active. Example: peb01
DR Size	Shows the number of bits in the data register chain when this instruction is active. Example: 34 bits
DR input value	Shows which bit pattern to shift into the data register in the Shift-DR state when this instruction is active. Multiple such lines may exist, e.g. to distinguish between reads and writes. Example: aaaaaaar xxxxxxxx xxxxxxxx xxxxxxxx xx
DR output value	Shows the bit pattern shifted out of the data register in the Shift-DR state when this instruction is active. Multiple such lines may exist, e.g. to distinguish between reads and writes. Example: xx xxxxxxxx xxxxxxxx xxxxxxxx xxxxxx <b>eb</b>

## 36.9.2 NEXUS\_ACCESS

This instruction allows Nexus-compliant access to on-chip debug registers through the SAB. OCD registers are addressed by their register index, as listed in the AVR32 Technical Reference Manual. The 7-bit register index and a read/write control bit, and the 32-bit data is accessed through the JTAG port.

The data register is alternately interpreted by the SAB as an address register and a data register. The SAB starts in address mode after the NEXUS\_ACCESS instruction is selected, and toggles between address and data mode each time a data scan completes with the busy bit cleared.

Starting in Run-Test/Idle, OCD registers are accessed in the following way:

1. Select the DR Scan path.
2. Scan in the 7-bit address for the OCD register and a direction bit (1=read, 0=write).
3. Go to Update-DR and re-enter Select-DR Scan.
4. For a read operation, scan out the contents of the addressed register. For a write operation, scan in the new contents of the register.
5. Return to Run-Test/Idle.

For any operation, the full 7 bits of the address must be provided. For write operations, 32 data bits must be provided, or the result will be undefined. For read operations, shifting may be terminated once the required number of bits have been acquired.

**Table 36-5.** NEXUS\_ACCESS details

Instructions	Details
IR input value	<b>10000</b> (0x10)
IR output value	peb01
DR Size	34 bits
DR input value (Address phase)	<b>aaaaaaar</b> xxxxxxxx xxxxxxxx xxxxxxxx xx
DR input value (Data read phase)	<b>xxxxxxxx xxxxxxxx xxxxxxxx xxxxxxxx</b> xx
DR input value (Data write phase)	<b>dddddddd dddddddd dddddddd dddddddd</b> xx
DR output value (Address phase)	xx xxxxxxxx xxxxxxxx xxxxxxxx xxxxxx <b>eb</b>
DR output value (Data read phase)	<b>eb dddddddd dddddddd dddddddd dddddddd</b>
DR output value (Data write phase)	xx <b>xxxxxxxx xxxxxxxx xxxxxxxx xxxxxx</b> <b>eb</b>

### 36.9.3 MEMORY\_SERVICE

This instruction allows access to registers in an optional Memory Service unit. Memory Service registers are addressed by their register index, as listed in the Memory Service documentation. The 7-bit register index and a read/write control bit, and the 32-bit data is accessed through the JTAG port.

The Memory Service unit may offer features such as CRC calculation of memory, debug trace support, and test features. Please refer to the Memory Service Unit documentation and the part specific documentation for details.

The data register is alternately interpreted by the SAB as an address register and a data register. The SAB starts in address mode after the MEMORY\_SERVICE instruction is selected, and toggles between address and data mode each time a data scan completes with the busy bit cleared.

Starting in Run-Test/Idle, Memory Service registers are accessed in the following way:

1. Select the DR Scan path.
2. Scan in the 7-bit address for the Memory Service register and a direction bit (1=read, 0=write).
3. Go to Update-DR and re-enter Select-DR Scan.
4. For a read operation, scan out the contents of the addressed register. For a write operation, scan in the new contents of the register.
5. Return to Run-Test/Idle.



For any operation, the full 7 bits of the address must be provided. For write operations, 32 data bits must be provided, or the result will be undefined. For read operations, shifting may be terminated once the required number of bits have been acquired.

**Table 36-6.** MEMORY\_SERVICE details

Instructions	Details
IR input value	<b>10100</b> (0x14)
IR output value	peb01
DR Size	34 bits
DR input value (Address phase)	<b>aaaaaar</b> xxxxxxxx xxxxxxxx xxxxxxxx xx
DR input value (Data read phase)	<b>xxxxxxxx xxxxxxxx xxxxxxxx xxxxxxxx</b> xx
DR input value (Data write phase)	<b>dddddddd dddddddd dddddddd dddddddd</b> xx
DR output value (Address phase)	xx xxxxxxxx xxxxxxxx xxxxxxxx xxxxxx <b>eb</b>
DR output value (Data read phase)	<b>eb dddddddd dddddddd dddddddd dddddddd</b>
DR output value (Data write phase)	xx <b>xxxxxxxx xxxxxxxx xxxxxxxx xxxxxx</b> <b>eb</b>

### 36.9.4 MEMORY\_SIZED\_ACCESS

This instruction allows access to the entire Service Access Bus data area. Data are accessed through a 36-bit byte index, a 2-bit size, a direction bit, and 8, 16, or 32 bits of data. Not all units mapped on the SAB bus may support all sizes of accesses, e.g. some may only support word accesses.

The data register is alternately interpreted by the SAB as an address register and a data register. The SAB starts in address mode after the MEMORY\_SIZED\_ACCESS instruction is selected, and toggles between address and data mode each time a data scan completes with the busy bit cleared.

The size field is encoded as in [Table 36-7](#).

**Table 36-7.** Size Field Semantics

Size field value	Access size	Data alignment
00	Byte (8 bits)	Address modulo 4 : data alignment 0: <b>ddddddd</b> xxxxxxxx xxxxxxxx xxxxxxxx 1: xxxxxxxx <b>ddddddd</b> xxxxxxxx xxxxxxxx 2: xxxxxxxx xxxxxxxx <b>ddddddd</b> xxxxxxxx 3: xxxxxxxx xxxxxxxx xxxxxxxx <b>ddddddd</b>

**Table 36-7.** Size Field Semantics

Size field value	Access size	Data alignment
01	Halfword (16 bits)	Address modulo 4 : data alignment 0: <b>ddddddd ddddddd</b> xxxxxxxx xxxxxxxx 1: Not allowed 2: xxxxxxxx xxxxxxxx <b>ddddddd ddddddd</b> 3: Not allowed
10	Word (32 bits)	Address modulo 4 : data alignment 0: <b>ddddddd ddddddd ddddddd ddddddd</b> 1: Not allowed 2: Not allowed 3: Not allowed
11	Reserved	N/A

Starting in Run-Test/Idle, SAB data are accessed in the following way:

1. Select the DR Scan path.
2. Scan in the 36-bit address of the data to access, a 2-bit access size, and a direction bit (1=read, 0=write).
3. Go to Update-DR and re-enter Select-DR Scan.
4. For a read operation, scan out the contents of the addressed area. For a write operation, scan in the new contents of the area.
5. Return to Run-Test/Idle.

For any operation, the full 36 bits of the address must be provided. For write operations, 32 data bits must be provided, or the result will be undefined. For read operations, shifting may be terminated once the required number of bits have been acquired.

**Table 36-8.** MEMORY\_SIZED\_ACCESS details

Instructions	Details
IR input value	<b>10101</b> (0x15)
IR output value	peb01
DR Size	39 bits
DR input value (Address phase)	aaaaaaaa aaaaaaaaa aaaaaaaaa aaaaaaaaa aaassr
DR input value (Data read phase)	<b>xxxxxxxx xxxxxxxx xxxxxxxx xxxxxxxx xxxxxxx</b>
DR input value (Data write phase)	<b>ddddddd ddddddd ddddddd ddddddd</b> xxxxxxx
DR output value (Address phase)	xxxxxxx xxxxxxxx xxxxxxxx xxxxxxxx xxxxxeb
DR output value (Data read phase)	xxxxxeb <b>ddddddd ddddddd ddddddd ddddddd</b>
DR output value (Data write phase)	xxxxxxx <b>xxxxxxxx xxxxxxxx xxxxxxxx xxxxxeb</b>

### 36.9.5 MEMORY\_WORD\_ACCESS

This instruction allows access to the entire Service Access Bus data area. Data are accessed through a 34-bit word index, a direction bit, and 32 bits of data. This instruction is identical to MEMORY\_SIZED\_ACCESS except that it always does word sized accesses. The size field is implied, and the two lowest address bits are removed.

Note: This instruction was previously known as MEMORY\_ACCESS, and is provided for backwards compatibility.

The data register is alternately interpreted by the SAB as an address register and a data register. The SAB starts in address mode after the MEMORY\_WORD\_ACCESS instruction is selected, and toggles between address and data mode each time a data scan completes with the busy bit cleared.

Starting in Run-Test/Idle, SAB data are accessed in the following way:

1. Select the DR Scan path.
2. Scan in the 34-bit address of the data to access, and a direction bit (1=read, 0=write).
3. Go to Update-DR and re-enter Select-DR Scan.
4. For a read operation, scan out the contents of the addressed area. For a write operation, scan in the new contents of the area.
5. Return to Run-Test/Idle.

For any operation, the full 34 bits of the address must be provided. For write operations, 32 data bits must be provided, or the result will be undefined. For read operations, shifting may be terminated once the required number of bits have been acquired.

**Table 36-9.** MEMORY\_WORD\_ACCESS details

Instructions	Details
IR input value	<b>10001</b> (0x11)
IR output value	peb01
DR Size	35 bits
DR input value (Address phase)	aaaaaaaa aaaaaaaaa aaaaaaaaa aaaaaaaaa aar
DR input value (Data read phase)	xxxxxxxx xxxxxxxx xxxxxxxx xxxxxxxx xxx
DR input value (Data write phase)	dddddddd dddddddd dddddddd dddddddd xxx
DR output value (Address phase)	xxxxxxxx xxxxxxxx xxxxxxxx xxxxxxxx xeb
DR output value (Data read phase)	xeb dddddddd dddddddd dddddddd dddddddd
DR output value (Data write phase)	xxx xxxxxxxx xxxxxxxx xxxxxxxx xxxxxeb

### 36.9.6 MEMORY\_BLOCK\_ACCESS

This instruction allows access to the entire SAB data area. Up to 32 bits of data are accessed at a time, while the address is sequentially incremented from the previously used address.

In this mode, the SAB address, size, and access direction is not provided with each access. Instead, the previous address is auto-incremented depending on the specified size and the previous operation repeated. The address must be set up in advance with MEMORY\_SIZE\_ACCESS or MEMORY\_WORD\_ACCESS. It is allowed, but not required, to shift data after shifting the address.

This instruction is primarily intended to speed up large quantities of sequential word accesses. It is possible to use it also for byte and halfword accesses, but the overhead in this is case much larger as 32 bits must still be shifted for each access.

The following sequence should be used:

1. Use the MEMORY\_SIZE\_ACCESS or MEMORY\_WORD\_ACCESS to read or write the first location.
2. Apply MEMORY\_BLOCK\_ACCESS in the IR Scan path.
3. Select the DR Scan path. The address will now have incremented by 1, 2, or 4 (corresponding to the next byte, halfword, or word location).
4. For a read operation, scan out the contents of the next addressed location. For a write operation, scan in the new contents of the next addressed location.
5. Go to Update-DR.
6. If the block access is not complete, return to Select-DR Scan and repeat the access.
7. If the block access is complete, return to Run-Test/Idle.

For write operations, 32 data bits must be provided, or the result will be undefined. For read operations, shifting may be terminated once the required number of bits have been acquired.

**Table 36-10.** MEMORY\_BLOCK\_ACCESS details

Instructions	Details
IR input value	<b>10010</b> (0x12)
IR output value	peb01
DR Size	34 bits
DR input value (Data read phase)	xxxxxxxx xxxxxxxx xxxxxxxx xxxxxxxx xx
DR input value (Data write phase)	dddddddd dddddddd dddddddd dddddddd xx
DR output value (Data read phase)	eb dddddddd dddddddd dddddddd dddddddd
DR output value (Data write phase)	xx xxxxxxxx xxxxxxxx xxxxxxxx xxxxxxeb

The overhead using block word access is 4 cycles per 32 bits of data, resulting in an 88% transfer efficiency, or 2.1 MBytes per second with a 20 MHz TCK frequency.

### 36.9.7 CANCEL\_ACCESS

If a very slow memory location is accessed during a SAB memory access, it could take a very long time until the busy bit is cleared, and the SAB becomes ready for the next operation. The CANCEL\_ACCESS instruction provides a possibility to abort an ongoing transfer and report a timeout to the user.

When the CANCEL\_ACCESS instruction is selected, the current access will be terminated as soon as possible. There are no guarantees about how long this will take, as the hardware may not always be able to cancel the access immediately. The SAB is ready to respond to a new command when the busy bit clears.

**Table 36-11.** CANCEL\_ACCESS details

Instructions	Details
IR input value	<b>10011</b> (0x13)
IR output value	peb01
DR Size	1
DR input value	x
DR output value	0

## 36.9.8 SYNC

This instruction allows external debuggers and testers to measure the ratio between the external JTAG clock and the internal system clock. The SYNC data register is a 16-bit counter that counts down to zero using the internal system clock. The busy bit stays high until the counter reaches zero.

Starting in Run-Test/Idle, SYNC instruction is used in the following way:

1. Select the DR Scan path.
2. Scan in an 16-bit counter value.
3. Go to Update-DR and re-enter Select-DR Scan.
4. Scan out the busy bit, and retry until the busy bit clears.
5. Calculate an approximation to the internal clock speed using the elapsed time and the counter value.
6. Return to Run-Test/Idle.

The full 16-bit counter value must be provided when starting the synch operation, or the result will be undefined. When reading status, shifting may be terminated once the required number of bits have been acquired.

**Table 36-12.** SYNC\_ACCESS details

Instructions	Details
IR input value	<b>10111</b> (0x17)
IR output value	peb01
DR Size	16 bits
DR input value	dddddddd dddddddd
DR output value	xxxxxxxx xxxxxxeb

## 36.9.9 AVR\_RESET

This instruction allows a debugger or tester to directly control separate reset domains inside the chip. The shift register contains one bit for each controllable reset domain. Setting a bit to one resets that domain and holds it in reset. Setting a bit to zero releases the reset for that domain.

See the device specific documentation for the number of reset domains, and what these domains are.

For any operation, all bits must be provided or the result will be undefined.

**Table 36-13.** AVR\_RESET details

Instructions	Details
IR input value	<b>01100</b> (0x0C)
IR output value	p0001
DR Size	Device specific.
DR input value	Device specific.
DR output value	Device specific.

## 36.9.10 CHIP\_ERASE

This instruction allows a programmer to completely erase all nonvolatile memories in a chip. This will also clear any security bits that are set, so the device can be accessed normally. In

devices without non-volatile memories this instruction does nothing, and appears to complete immediately.

The erasing of non-volatile memories starts as soon as the CHIP\_ERASE instruction is selected. The CHIP\_ERASE instruction selects a 1 bit bypass data register.

A chip erase operation should be performed as:

1. Scan in the HALT instruction
2. Scan in the value 1 to halt the CPU
3. Stay in Run-Test/Idle for 10 TCK cycles to let the halt command propagate properly
4. Scan in the CHIP\_ERASE instruction
5. Keep scanning the CHIP\_ERASE instruction until the busy bit is cleared and the protection bit is cleared.
6. Scan in the HALT instruction
7. Scan in the value 0 to release the CPU
8. Return to Run-Test/Idle
9. Stay in Run-Test/Idle for 10 TCK cycles to let the halt command propagate properly.

**Table 36-14.** CHIP\_ERASE details

Instructions	Details
IR input value	01111 (0x0F)
IR output value	p0b01 Where b is the <i>busy</i> bit.
DR Size	1 bit
DR input value	x
DR output value	0

## 36.9.11 HALT

This instruction allows a programmer to easily stop the CPU to ensure that it does not execute invalid code during programming.

This instruction selects a 1-bit halt register. Setting this bit to one halts the CPU. Setting this bit to zero releases the CPU to run normally. The value shifted out from the data register is one if the CPU is halted.

The HALT instruction can be used in the following way:

10. Scan in the value 1 to halt the CPU
11. Stay in Run-Test/Idle for 10 TCK cycles to let the command propagate properly
12. Use any MEMORY\_\* instructions to program the device
13. Scan in the HALT instruction
14. Scan in the value 0 to release the CPU
15. Return to Run-Test/Idle

16. Stay in Run-Test/Idle for 10 TCK cycles to let the command propagate properly - the device now runs with the new code.

**Table 36-15.** HALT details

Instructions	Details
IR input value	<b>11100</b> (0x1C)
IR output value	p0001
DR Size	1 bit
DR input value	d
DR output value	d

## 36.10 JTAG Data Registers

The following device specific registers can be selected as JTAG scan chain depending on the instruction loaded in the JTAG Instruction Register. Additional registers exist, but are implicitly described in the functional description of the relevant instructions.

### 36.10.1 Device Identification Register

The Device Identification Register contains a unique identifier for each product. The register is selected by the IDCODE instruction, which is the default instruction after a JTAG reset.

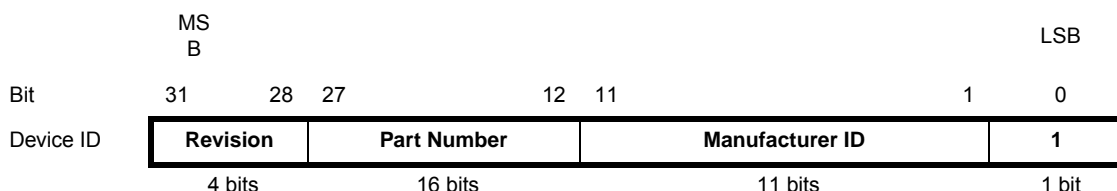

**Revision** This is a 4 bit number identifying the revision of the component. Rev A = 0x0, B = 0x1, etc.

**Part Number** The part number is a 16 bit code identifying the component.

**Manufacturer ID** The Manufacturer ID is a 11 bit code identifying the manufacturer. The JTAG manufacturer ID for ATMEL is 0x01F.

#### 36.10.1.1 Device specific ID codes

The different device configurations have different JTAG ID codes, as shown in [Table 36-16](#). Note that if the flash controller is statically reset, the ID code will be undefined.

**Table 36-16.** Device and JTAG ID

Device name	JTAG ID code (r is the revision number)
AT32UC3A0512	0xr1EDC03F
AT32UC3A0256	0xr1EDF03F
AT32UC3A0128	0xr1EE203F
AT32UC3A1512	0xr1EDD03F
AT32UC3A1256	0xr1EE003F
AT32UC3A1128	0xr1EE303F

### 36.10.2 Reset register

The reset register is selected by the AVR\_RESET instruction and contains one bit for each reset domain in the device. Setting each bit to one will keep that domain reset until the bit is cleared.

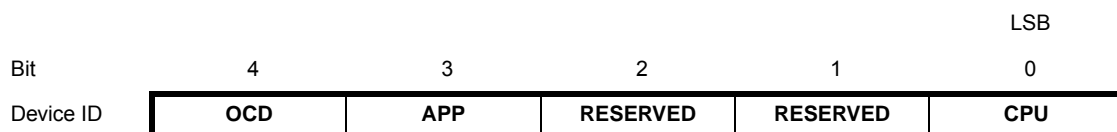



<b>CPU</b>	CPU
<b>APP</b>	HSB and PB buses
<b>OCD</b>	On-Chip Debug logic and registers
<b>RSERVED</b>	No effect

Note: This register is primarily intended for compatibility with other AVR32 devices. Certain operations may not function correctly when parts of the system are reset. It is generally recommended to only write 0x11111 or 0x00000 to these bits to ensure no unintended side effects occur.

### 36.10.3 Boundary-Scan Chain

The Boundary-Scan Chain has the capability of driving and observing the logic levels on the digital I/O pins, as well as driving and observing the logic levels between the digital I/O pins and the internal logic. Typically, output value, output enable, and input data are all available in the boundary scan chain.

The boundary scan chain is described in the BDSL (Boundary Scan Description Language) file available at the Atmel web site.

### 36.11 SAB address map

The Service Access Bus (SAB) gives the user access to the internal address space and other features through a 36 bits address space. The 4 MSBs identify the slave number, while the 32 LSBs are decoded within the slave's address space. The SAB slaves are shown in [Table 36-17](#).

**Table 36-17.** SAB Slaves, addresses and descriptions.

Slave	Address [35:32]	Description
Unallocated	0x0	Intentionally unallocated
OCD	0x1	OCD registers
HSB	0x4	HSB memory space, as seen by the CPU
HSB	0x5	Alternative mapping for HSB space, for compatibility with other AVR32 devices.
Memory Service Unit	0x6	Memory Service Unit registers
Reserved	Other	Unused

## 37. Boot Sequence

This chapter summarizes the boot sequence of the AT32UC3A. The behaviour after power-up is controlled by the Power Manager. For specific details, refer to [Section 13. "Power Manager \(PM\)" on page 53](#).

### 37.1 Starting of clocks

After power-up, the device will be held in a reset state by the Power-On Reset circuitry, until the power has stabilized throughout the device. Once the power has stabilized, the device will use the internal RC Oscillator as clock source.

On system start-up, the PLLs are disabled. All clocks to all modules are running. No clocks have a divided frequency, all parts of the system receives a clock with the same frequency as the internal RC Oscillator.

### 37.2 Fetching of initial instructions

After reset has been released, the AVR32 UC CPU starts fetching instructions from the reset address, which is 0x8000\_0000. This address points to the first address in the internal Flash.

The code read from the internal Flash is free to configure the system to use for example the PLLs, to divide the frequency of the clock routed to some of the peripherals, and to gate the clocks to unused peripherals.

### 38. Electrical Characteristics

#### 38.1 Absolute Maximum Ratings\*

Operating Temperature.	
Storage Temperature.	-60°C to +150°C
Voltage on Input Pin with respect to Ground except for PC00, PC01, PC02, PC03, PC04, PC05.....	-0.3V to 5.5V
Voltage on Input Pin with respect to Ground for PC00, PC01, PC02, PC03, PC04, PC05.....	-0.3V to 3.6V
Maximum Operating Voltage (VDDCORE, VDDPLL).	1.95V
Maximum Operating Voltage (VDDIO, VDDIN, VDDANA).	3.6V
Total DC Output Current on all I/O Pin for TQFP100 package .	370 mA
for LQGP144 package .	470 mA

-40-C to +85-C \*NOTICE:  
Stresses beyond those listed under “Absolute Maximum Ratings” may cause permanent damage to the device. This is a stress rating only and functional operation of the device at these or other conditions beyond those indicated in the operational sections of this specification is not implied. Exposure to absolute maximum rating conditions for extended periods may affect

## 38.2 DC Characteristics

The following characteristics are applicable to the operating temperature range:  $T_A = -40^{\circ}\text{C}$  to  $85^{\circ}\text{C}$ , unless otherwise specified and are certified for a junction temperature up to  $T_J = 100^{\circ}\text{C}$ .

**Table 38-1.** DC Characteristics

Symbol	Parameter	Condition	Min.	Typ.	Max	Units
$V_{VDDCORE}$	DC Supply Core		1.65		1.95	V
$V_{VDDPLL}$	DC Supply PLL		1.65		1.95	V
$V_{VDDIO}$	DC Supply Peripheral I/Os		3.0		3.6	V
$V_{REF}$	Analog reference voltage		2.6		3.6	V
$V_{IL}$	Input Low-level Voltage		-0.3		+0.8	V
$V_{IH}$	Input High-level Voltage	All GPIOs except for PC00, PC01, PC02, PC03, PC04, PC05.	2.0		5.5V	V
		PC00, PC01, PC02, PC03, PC04, PC05.	2.0		3.6V	V
$V_{OL}$	Output Low-level Voltage	$I_{OL} = -4\text{mA}$ for PA0-PA20, PB0, PB4-PB9, PB11-PB18, PB24-PB26, PB29-PB31, PX0-PX39			0.4	V
		$I_{OL} = -8\text{mA}$ for PA21-PA30, PB1-PB3, PB10, PB19-PB23, PB27-PB28, PC0-PC5			0.4	V
$V_{OH}$	Output High-level Voltage	$I_{OH} = 4\text{mA}$ for PA0-PA20, PB0, PB4-PB9, PB11-PB18, PB24-PB26, PB29-PB31, PX0-PX39	$V_{VDDIO} - 0.4$			V
		$I_{OH} = 8\text{mA}$ for PA21-PA30, PB1-PB3, PB10, PB19-PB23, PB27-PB28, PC0-PC5	$V_{VDDIO} - 0.4$			V
$I_{OL}$	Output Low-level Current	PA0-PA20, PB0, PB4-PB9, PB11-PB18, PB24-PB26, PB29-PB31, PX0-PX39			-4	mA
		PA21-PA30, PB1-PB3, PB10, PB19-PB23, PB27-PB28, PC0-PC5			-8	mA
$I_{OH}$	Output High-level Current	PA0-PA20, PB0, PB4-PB9, PB11-PB18, PB24-PB26, PB29-PB31, PX0-PX39			4	mA
		PA21-PA30, PB1-PB3, PB10, PB19-PB23, PB27-PB28, PC0-PC5			8	mA
$I_{LEAK}$	Input Leakage Current	Pullup resistors disabled			1	$\mu\text{A}$
$C_{IN}$ Input Capacitance		TQFP100 Package		7		pF
		LQFP144 Package		7		pF
$R_{PULLUP}$	Pull-up Resistance	All GPIO and RESET_N pin.	10K	15K		Ohm

## 38.3 Regulator characteristics

**Table 38-2.** Electrical characteristics

Symbol	Parameter	Condition	Min.	Typ.	Max.	Units
V <sub>VDDIN</sub>	Supply voltage (input)		3	3.3	3.6	V
V <sub>VDDOUT</sub>	Supply voltage (output)		1.81	1.85	1.89	V
I <sub>OUT</sub>	Maximum DC output current with V <sub>VDDIN</sub> = 3.3V				100	mA
	Maximum DC output current with V <sub>VDDIN</sub> = 2.7V				90	mA
I <sub>SCR</sub>	Static Current of internal regulator	Low Power mode (stop, deep stop or static) at T <sub>A</sub> =25°C		10		µA

**Table 38-3.** Decoupling requirements

Symbol	Parameter	Condition	Typ.	Techno.	Units
C <sub>IN1</sub>	Input Regulator Capacitor 1		1	NPO	nF
C <sub>IN2</sub>	Input Regulator Capacitor 2		4.7	X7R	µF
C <sub>OUT1</sub>	Output Regulator Capacitor 1		470	NPO	pF
C <sub>OUT2</sub>	Output Regulator Capacitor 2		2.2	X7R	µF

## 38.4 Analog characteristics

**Table 38-4.** Electrical characteristics

Symbol	Parameter	Condition	Min.	Typ.	Max.	Units
V <sub>ADVREF</sub>	Analog voltage reference (input)		2.6		3.6	V

**Table 38-5.** Decoupling requirements

Symbol	Parameter	Condition	Typ.	Techno	Units
C <sub>VREF1</sub>	Voltage reference Capacitor 1		10	-	nF
C <sub>VREF2</sub>	Voltage reference Capacitor 2		1	-	µF

### 38.4.1 BOD

**Table 38-6.** BODLEVEL Values

BODLEVEL Value	Typ.	Typ.	Typ.	Units.
00 0000b	1.40	1.47	1.55	V
01 0111b	1.45	1.52	1.6	V
01 1111b	1.55	1.6	1.65	V
10 0111b	1.65	1.69	1.75	V

The values in [Table 38-6](#) describes the values of the BODLEVEL in the flash FGPFRR register.

**Table 38-7.** BOD Timing

Symbol	Parameter	Test Conditions	Typ.	Max.	Units.
$T_{BOD}$	Minimum time with $V_{DDCORE} < V_{BOD}$ to detect power failure	Falling $V_{DDCORE}$ from 1.8V to 1.1V	300	800	ns

## 38.4.2 POR

**Table 38-8.** Electrical Characteristic

Symbol	Parameter	Test Conditions	Min.	Typ.	Max.	Units.
$V_{DDRR}$	$V_{DDCORE}$ rise rate to ensure power-on-reset		0.01			V/ms
$V_{SSFR}$	$V_{DDCORE}$ fall rate to ensure power-on-reset		0.01		400	V/ms
$V_{POR+}$	Rising threshold voltage: voltage up to which device is kept under reset by POR on rising $V_{DDCORE}$	Rising $V_{DDCORE}$ : $V_{RESTART} \rightarrow V_{POR+}$	1.35	1.5	1.6	V
$V_{POR-}$	Falling threshold voltage: voltage when POR resets device on falling $V_{DDCORE}$	Falling $V_{DDCORE}$ : 1.8V $\rightarrow V_{POR+}$	1.25	1.3	1.4	V
$V_{RESTART}$	On falling $V_{DDCORE}$ , voltage must go down to this value before supply can rise again to ensure reset signal is released at $V_{POR+}$	Falling $V_{DDCORE}$ : 1.8V $\rightarrow V_{RESTART}$	-0.1		0.5	V
$T_{POR}$	Minimum time with $V_{DDCORE} < V_{POR-}$	Falling $V_{DDCORE}$ : 1.8V $\rightarrow$ 1.1V		15		us
$T_{RST}$	Time for reset signal to be propagated to system			200	400	us

## 38.5 Power Consumption

The values in [Table 38-9](#) and [Table 38-10 on page 769](#) are measured values of power consumption with operating conditions as follows:

- $V_{DDIO} = 3.3V$
- $V_{DDCORE} = V_{DDPLL} = 1.8V$
- $T_A = 25^{\circ}C, T_A = 85^{\circ}C$
- I/Os are configured in input, pull-up enabled.

**Figure 38-1.** Measurement setup

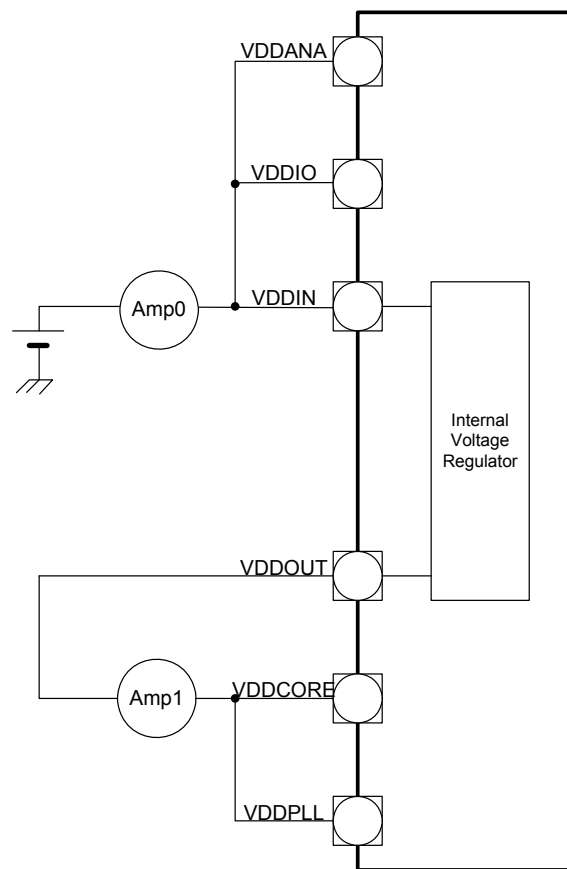

These figures represent the power consumption measured on the power supplies.

**Table 38-9.** Power Consumption for Different Modes

Mode	Conditions		Typ.	Unit
Active	Typ : Ta =25 °C CPU running from flash <sup>(1)</sup> . VDDIN=3.3 V. VDDCORE =1.8V. CPU clocked from PLL0 at f MHz Voltage regulator is on. XIN0 : external clock. <sup>(1)</sup> XIN1 stopped. XIN32 stopped PLL0 running All peripheral clocks activated. GPIOs on internal pull-up. JTAG unconnected with ext pull-up.	f = 12 MHz	9	mA
		f = 24 MHz	15	mA
		f = 36MHz	20	mA
		f = 50 MHz	28	mA
		f = 66 MHz	36.3	mA
Idle	Typ : Ta = 25 °C CPU running from flash <sup>(1)</sup> . VDDIN=3.3 V. VDDCORE =1.8V. CPU clocked from PLL0 at f MHz Voltage regulator is on. XIN0 : external clock. XIN1 stopped. XIN32 stopped PLL0 running All peripheral clocks activated. GPIOs on internal pull-up. JTAG unconnected with ext pull-up.	f = 12 MHz	5	mA
		f = 24 MHz	10	mA
		f = 36MHz	14	mA
		f = 50 MHz	19	mA
		f = 66 MHz	25.5	mA
Frozen	Typ : Ta = 25 °C CPU running from flash <sup>(1)</sup> . CPU clocked from PLL0 at f MHz Voltage regulator is on. XIN0 : external clock. XIN1 stopped. XIN32 stopped PLL0 running All peripheral clocks activated. GPIOs on internal pull-up. JTAG unconnected with ext pull-up.	f = 12 MHz	3	mA
		f = 24 MHz	6	mA
		f = 36MHz	9	mA
		f = 50 MHz	13	mA
		f = 66 MHz	16.8	mA
Standby	Typ : Ta = 25 °C CPU running from flash <sup>(1)</sup> . CPU clocked from PLL0 at f MHz Voltage regulator is on. XIN0 : external clock. XIN1 stopped. XIN32 stopped PLL0 running All peripheral clocks activated. GPIOs on internal pull-up. JTAG unconnected with ext pull-up.	f = 12 MHz	1	mA
		f = 24 MHz	2	mA
		f = 36MHz	3	mA
		f = 50 MHz	4	mA
		f = 66 MHz	4.8	mA



**Table 38-9.** Power Consumption for Different Modes

Mode	Conditions		Typ.	Unit
Stop	Typ : Ta = 25 °C. CPU is in stop mode GPIOs on internal pull-up. All peripheral clocks de-activated. DM and DP pins connected to ground. XIN0,Xin1 and XIN2 are stopped	on Amp0	47	uA
		on Amp1	40	uA
Deepstop	Typ : Ta = 25 °C.CPU is in deepstop mode GPIOs on internal pull-up. All peripheral clocks de-activated. DM and DP pins connected to ground. XIN0,Xin1 and XIN2 are stopped	on Amp0	36	uA
		on Amp1	28	uA
Static	Typ : Ta = 25 °C. CPU is in static mode GPIOs on internal pull-up. All peripheral clocks de-activated. DM and DP pins connected to ground. XIN0,Xin1 and XIN2 are stopped	on Amp0	25	uA
		on Amp1	14	uA

1. Core frequency is generated from XIN0 using the PLL so that 140 MHz < fpll0 < 160 MHz and 10 MHz < fxin0 < 12MHz

**Table 38-10.** Power Consumption by Peripheral in Active Mode

Peripheral	Typ.	Unit
GPIO	37	μA/MHz
SMC	10	
SDRAMC	4	
ADC	18	
EBI	31	
INTC	25	
TWI	14	
MACB	45	
PDCA	30	
PWM	36	
RTC	7	
SPI	13	
SSC	13	
TC	10	
USART	35	
USB	45	

## 38.6 Clock Characteristics

These parameters are given in the following conditions:

- $V_{DDCORE} = 1.8V$
- Ambient Temperature = 25°C

### 38.6.1 CPU/HSB Clock Characteristics

**Table 38-11.** Core Clock Waveform Parameters

Symbol	Parameter	Conditions	Min	Max	Units
$1/(t_{CPCPU})$	CPU Clock Frequency			66	MHz
$t_{CPCPU}$	CPU Clock Period		15,15		ns

### 38.6.2 PBA Clock Characteristics

**Table 38-12.** PBA Clock Waveform Parameters

Symbol	Parameter	Conditions	Min	Max	Units
$1/(t_{CPPBA})$	PBA Clock Frequency			66	MHz
$t_{CPPBA}$	PBA Clock Period		15,15		ns

### 38.6.3 PBB Clock Characteristics

**Table 38-13.** PBB Clock Waveform Parameters

Symbol	Parameter	Conditions	Min	Max	Units
$1/(t_{CPPBB})$	PBB Clock Frequency			66	MHz
$t_{CPPBB}$	PBB Clock Period		15,15		ns

## 38.7 Crystal Oscillator Characteristics

The following characteristics are applicable to the operating temperature range:  $T_A = -40^{\circ}C$  to  $85^{\circ}C$  and worst case of power supply, unless otherwise specified.

### 38.7.1 32 KHz Oscillator Characteristics

**Table 38-14.** 32 KHz Oscillator Characteristics

Symbol	Parameter	Conditions	Min	Typ	Max	Unit
$1/(t_{CP32KHz})$	Crystal Oscillator Frequency				32 768	Hz
$C_L$	Equivalent Load Capacitance		6		12.5	pF
$t_{ST}$	Startup Time	$C_L = 6pF^{(1)}$ $C_L = 12.5pF^{(1)}$			600 1200	ms
$I_{OSC}$	Current Consumption	Active mode			1.8	$\mu A$
		Standby mode			0.1	$\mu A$

Note: 1.  $C_L$  is the equivalent load capacitance.

## 38.7.2 Main Oscillators Characteristics

**Table 38-15.** Main Oscillator Characteristics

Symbol	Parameter	Conditions	Min	Typ	Max	Unit
$1/(t_{CPMAIN})$	Crystal Oscillator Frequency		0.45		16	MHz
$C_{L1}, C_{L2}$	Internal Load Capacitance ( $C_{L1} = C_{L2}$ )			12		pF
	Duty Cycle		40	50	60	%
$t_{ST}$	Startup Time	8 MHz			4	ms
$1/(t_{CPXIN})$	XIN Clock Frequency	External clock			50	MHz
		Crystal	0.45		16	MHz
$t_{CHXIN}$	XIN Clock High Half-period		$0.4 \times t_{CPXIN}$		$0.6 \times t_{CPXIN}$	
$t_{CLXIN}$	XIN Clock Low Half-period		$0.4 \times t_{CPXIN}$		$0.6 \times t_{CPXIN}$	
$C_{IN}$	XIN Input Capacitance			7		pF

## 38.7.3 PLL Characteristics

**Table 38-16.** Phase Lock Loop Characteristics

Symbol	Parameter	Conditions	Min	Typ	Max	Unit
$F_{OUT}$	Output Frequency		80		240	MHz
$F_{IN}$	Input Frequency		4		16	MHz
$I_{PLL}$	Current Consumption	active mode ( $F_{out}=80\text{MHz}$ )		250		$\mu\text{A}$
		active mode ( $F_{out}=240\text{MHz}$ )		600		$\mu\text{A}$

## 38.8 ADC Characteristics

**Table 38-17.** Channel Conversion Time and ADC Clock

Parameter	Conditions	Min	Typ	Max	Units
ADC Clock Frequency	10-bit resolution mode			5	MHz
ADC Clock Frequency	8-bit resolution mode			8	MHz
Startup Time	Return from Idle Mode			20	μs
Track and Hold Acquisition Time		600			ns
Conversion Time	ADC Clock = 5 MHz			2	μs
Conversion Time	ADC Clock = 8 MHz			1.25	μs
Throughput Rate	ADC Clock = 5 MHz			384 <sup>(1)</sup>	kSPS
Throughput Rate	ADC Clock = 8 MHz			533 <sup>(2)</sup>	kSPS

- Notes:
1. Corresponds to 13 clock cycles at 5 MHz: 3 clock cycles for track and hold acquisition time and 10 clock cycles for conversion.
  2. Corresponds to 15 clock cycles at 8 MHz: 5 clock cycles for track and hold acquisition time and 10 clock cycles for conversion.

**Table 38-18.** External Voltage Reference Input

Parameter	Conditions	Min	Typ	Max	Units
ADVREF Input Voltage Range		2.6		VDDANA	V
ADVREF Average Current	On 13 samples with ADC Clock = 5 MHz		200	250	μA
Current Consumption on VDDANA				1.25	mA

Note: ADVREF should be connected to GND to avoid extra consumption in case ADC is not used.

**Table 38-19.** Analog Inputs

Parameter	Min	Typ	Max	Units
Input Voltage Range	0		V <sub>ADVREF</sub>	
Input Leakage Current		1		μA
Input Capacitance		17		pF

**Table 38-20.** Transfer Characteristics in 8-bit mode

Parameter	Conditions	Min	Typ	Max	Units
Resolution			8		Bit
Absolute Accuracy	f=5MHz			0.8	LSB
	f=8MHz			1.5	LSB
Integral Non-linearity	f=5MHz		0.35	0.5	LSB
	f=8MHz		0.5	1.0	LSB
Differential Non-linearity	f=5MHz		0.3	0.5	LSB
	f=8MHz		0.5	1.0	LSB
Offset Error	f=5MHz	-0.5		0.5	LSB
Gain Error	f=5MHz	-0.5		0.5	LSB

**Table 38-21.** Transfer Characteristics in 10-bit mode

Parameter	Conditions	Min	Typ	Max	Units
Resolution			10		Bit
Absolute Accuracy	f=5MHz			3	LSB
Integral Non-linearity	f=5MHz		1.5	2	LSB
Differential Non-linearity	f=5MHz		1	2	LSB
	f=2.5MHz		0.6	1	LSB
Offset Error	f=5MHz	-2		2	LSB
Gain Error	f=5MHz	-2		2	LSB

## 38.9 EBI Timings

These timings are given for worst case process, T = 85-C, VDDCORE = 1.65V, VDDIO = 3V and 40 pF load capacitance.

**Table 38-22.** SMC Clock Signal.

Symbol	Parameter	Max <sup>(1)</sup>	Units
1/(t <sub>CPSMC</sub> )	SMC Controller Clock Frequency	1/(t <sub>CPCPU</sub> )	MHz

Note: 1. The maximum frequency of the SMC interface is the same as the max frequency for the HSB.

**Table 38-23.** SMC Read Signals with Hold Settings

Symbol	Parameter	Min	Units
<b>NRD Controlled (READ_MODE = 1)</b>			
SMC <sub>1</sub>	Data Setup before NRD High	12	ns
SMC <sub>2</sub>	Data Hold after NRD High	0	
SMC <sub>3</sub>	NRD High to NBS0/A0 Change <sup>(1)</sup>	nrd hold length * t <sub>CPSMC</sub> - 1.3	
SMC <sub>4</sub>	NRD High to NBS1 Change <sup>(1)</sup>	nrd hold length * t <sub>CPSMC</sub> - 1.3	
SMC <sub>5</sub>	NRD High to NBS2/A1 Change <sup>(1)</sup>	nrd hold length * t <sub>CPSMC</sub> - 1.3	
SMC <sub>6</sub>	NRD High to NBS3 Change <sup>(1)</sup>	nrd hold length * t <sub>CPSMC</sub> - 1.3	
SMC <sub>7</sub>	NRD High to A2 - A25 Change <sup>(1)</sup>	nrd hold length * t <sub>CPSMC</sub> - 1.3	
SMC <sub>8</sub>	NRD High to NCS Inactive <sup>(1)</sup>	(nrd hold length - ncs rd hold length) * t <sub>CPSMC</sub> - 2.3	
SMC <sub>9</sub>	NRD Pulse Width	nrd pulse length * t <sub>CPSMC</sub> - 1.4	
<b>NRD Controlled (READ_MODE = 0)</b>			
SMC <sub>10</sub>	Data Setup before NCS High	11.5	ns
SMC <sub>11</sub>	Data Hold after NCS High	0	
SMC <sub>12</sub>	NCS High to NBS0/A0 Change <sup>(1)</sup>	ncs rd hold length * t <sub>CPSMC</sub> - 2.3	
SMC <sub>13</sub>	NCS High to NBS0/A0 Change <sup>(1)</sup>	ncs rd hold length * t <sub>CPSMC</sub> - 2.3	
SMC <sub>14</sub>	NCS High to NBS2/A1 Change <sup>(1)</sup>	ncs rd hold length * t <sub>CPSMC</sub> - 2.3	
SMC <sub>15</sub>	NCS High to NBS3 Change <sup>(1)</sup>	ncs rd hold length * t <sub>CPSMC</sub> - 2.3	
SMC <sub>16</sub>	NCS High to A2 - A25 Change <sup>(1)</sup>	ncs rd hold length * t <sub>CPSMC</sub> - 4	
SMC <sub>17</sub>	NCS High to NRD Inactive <sup>(1)</sup>	ncs rd hold length - nrd hold length) * t <sub>CPSMC</sub> - 1.3	
SMC <sub>18</sub>	NCS Pulse Width	ncs rd pulse length * t <sub>CPSMC</sub> - 3.6	

Note: 1. hold length = total cycle duration - setup duration - pulse duration. "hold length" is for "ncs rd hold length" or "nrd hold length".

**Table 38-24.** SMC Read Signals with no Hold Settings

Symbol	Parameter	Min	Units
<b>NRD Controlled (READ_MODE = 1)</b>			
SMC <sub>19</sub>	Data Setup before NRD High	13.7	ns
SMC <sub>20</sub>	Data Hold after NRD High	1	
<b>NRD Controlled (READ_MODE = 0)</b>			
SMC <sub>21</sub>	Data Setup before NCS High	13.3	ns
SMC <sub>22</sub>	Data Hold after NCS High	0	

**Table 38-25.** SMC Write Signals with Hold Settings

Symbol	Parameter	Min	Units
<b>NRD Controlled (READ_MODE = 1)</b>			
SMC <sub>23</sub>	Data Out Valid before NWE High	$(nwe \text{ pulse length} - 1) * t_{CPSMC} - 0.9$	ns
SMC <sub>24</sub>	Data Out Valid after NWE High <sup>(1)</sup>	$nwe \text{ hold length} * t_{CPSMC} - 6$	
SMC <sub>25</sub>	NWE High to NBS0/A0 Change <sup>(1)</sup>	$nwe \text{ hold length} * t_{CPSMC} - 1.9$	
SMC <sub>26</sub>	NWE High to NBS1 Change <sup>(1)</sup>	$nwe \text{ hold length} * t_{CPSMC} - 1.9$	
SMC <sub>29</sub>	NWE High to NBS2/A1 Change <sup>(1)</sup>	$nwe \text{ hold length} * t_{CPSMC} - 1.9$	
SMC <sub>30</sub>	NWE High to NBS3 Change <sup>(1)</sup>	$nwe \text{ hold length} * t_{CPSMC} - 1.9$	
SMC <sub>31</sub>	NWE High to A2 - A25 Change <sup>(1)</sup>	$nwe \text{ hold length} * t_{CPSMC} - 1.7$	
SMC <sub>32</sub>	NWE High to NCS Inactive <sup>(1)</sup>	$(nwe \text{ hold length} - ncs \text{ wr hold length}) * t_{CPSMC} - 2.9$	
SMC <sub>33</sub>	NWE Pulse Width	$nwe \text{ pulse length} * t_{CPSMC} - 0.9$	
<b>NRD Controlled (READ_MODE = 0)</b>			
SMC <sub>34</sub>	Data Out Valid before NCS High	$(ncs \text{ wr pulse length} - 1) * t_{CPSMC} - 4.6$	ns
SMC <sub>35</sub>	Data Out Valid after NCS High <sup>(1)</sup>	$ncs \text{ wr hold length} * t_{CPSMC} - 5.8$	
SMC <sub>36</sub>	NCS High to NWE Inactive <sup>(1)</sup>	$(ncs \text{ wr hold length} - nwe \text{ hold length}) * t_{CPSMC} - 0.6$	

Note: 1. hold length = total cycle duration - setup duration - pulse duration. "hold length" is for "ncs wr hold length" or "nwe hold length"

**Table 38-26.** SMC Write Signals with No Hold Settings (NWE Controlled only).

Symbol	Parameter	Min	Units
SMC <sub>37</sub>	NWE Rising to A2-A25 Valid	5.4	ns
SMC <sub>38</sub>	NWE Rising to NBS0/A0 Valid	5	
SMC <sub>39</sub>	NWE Rising to NBS1 Change	5	
SMC <sub>40</sub>	NWE Rising to A1/NBS2 Change	5	
SMC <sub>41</sub>	NWE Rising to NBS3 Change	5	
SMC <sub>42</sub>	NWE Rising to NCS Rising	5.1	
SMC <sub>43</sub>	Data Out Valid before NWE Rising	$(nwe \text{ pulse length} - 1) * t_{CPSMC} - 1.2$	
SMC <sub>44</sub>	Data Out Valid after NWE Rising	5	
SMC <sub>45</sub>	NWE Pulse Width	$nwe \text{ pulse length} * t_{CPSMC} - 0.9$	

**Figure 38-2.** SMC Signals for NCS Controlled Accesses.

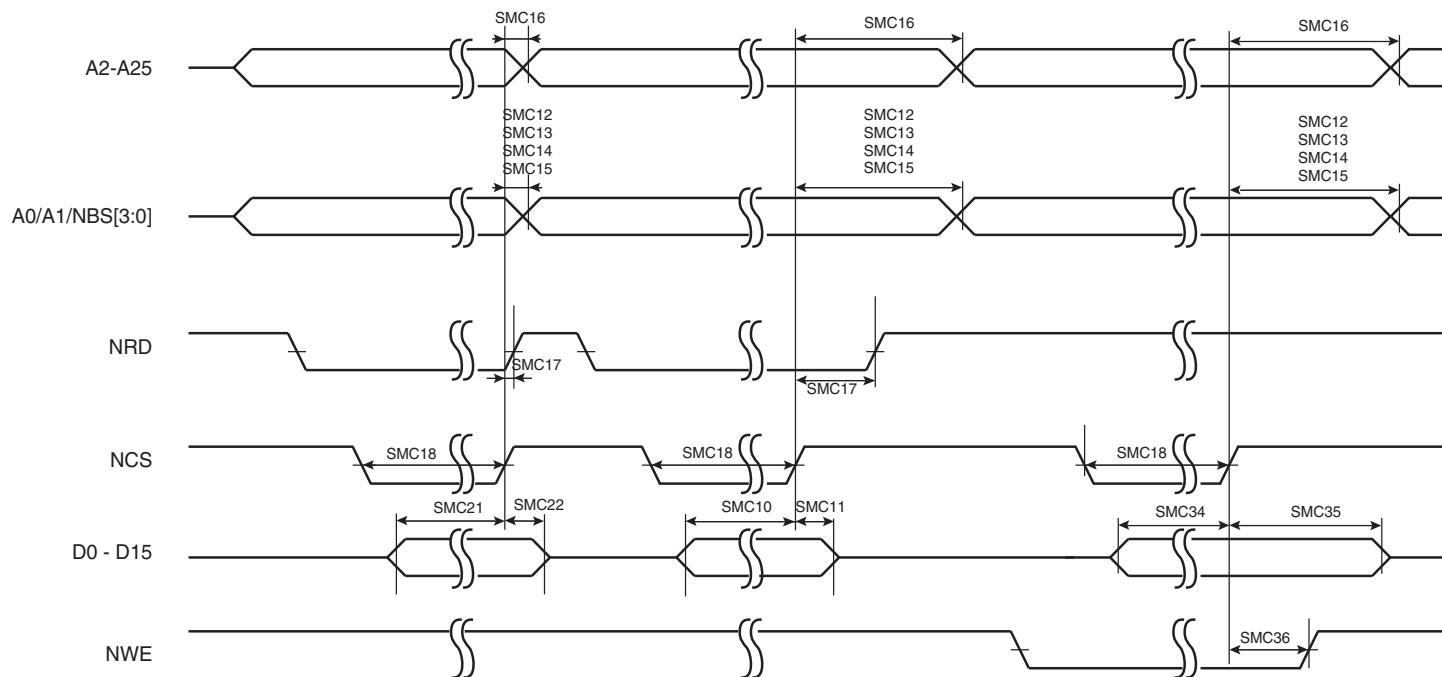



**Figure 38-3.** SMC Signals for NRD and NRW Controlled Accesses.

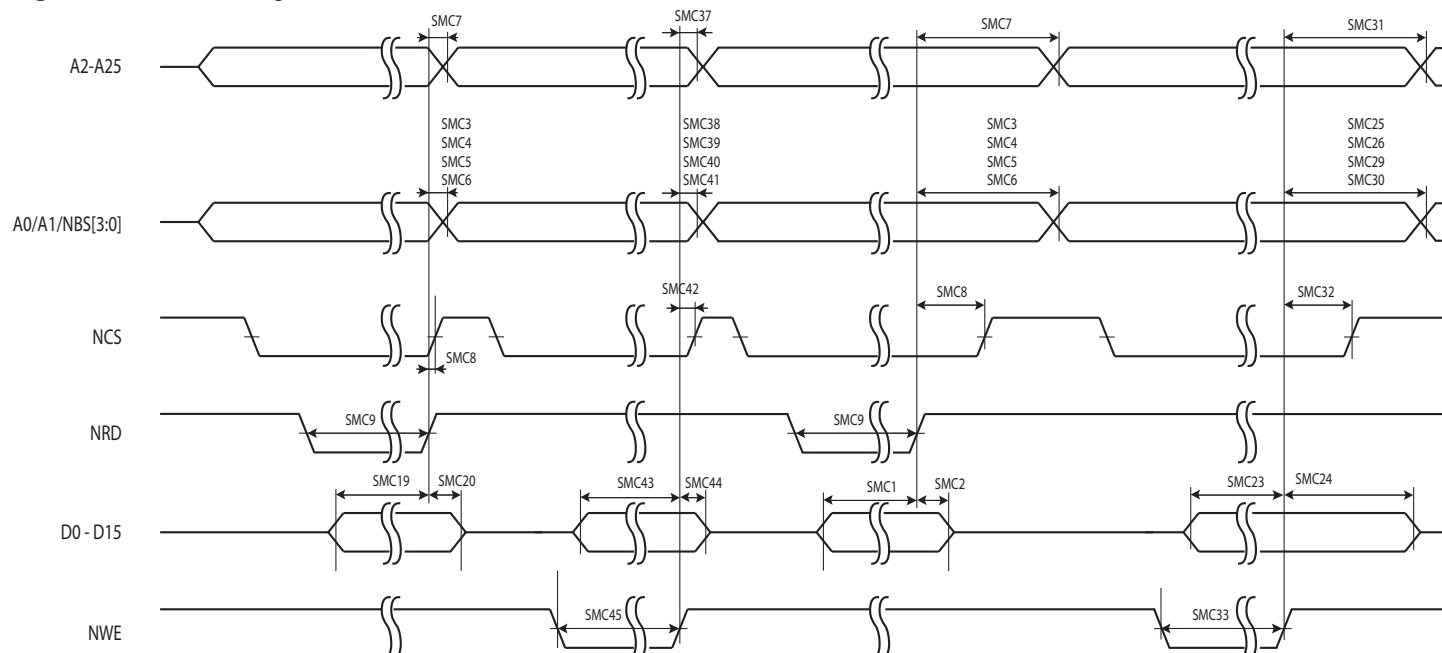

### 38.9.1 SDRAM Signals

These timings are given for 10 pF load on SDCK and 40 pF on other signals.

**Table 38-27.** SDRAM Clock Signal.

Symbol	Parameter	Max <sup>(1)</sup>	Units
$1/(t_{CPDCK})$	SDRAM Controller Clock Frequency	$1/(t_{cpCPU})$	MHz

Note: 1. The maximum frequency of the SDRAMC interface is the same as the max frequency for the HSB.

**Table 38-28.** SDRAM Clock Signal.

Symbol	Parameter	Min	Units
SDRAMC <sub>1</sub>	SDCKE High before SDCK Rising Edge	7.4	ns
SDRAMC <sub>2</sub>	SDCKE Low after SDCK Rising Edge	3.2	
SDRAMC <sub>3</sub>	SDCKE Low before SDCK Rising Edge	7	
SDRAMC <sub>4</sub>	SDCKE High after SDCK Rising Edge	2.9	
SDRAMC <sub>5</sub>	SDCS Low before SDCK Rising Edge	7.5	
SDRAMC <sub>6</sub>	SDCS High after SDCK Rising Edge	1.6	
SDRAMC <sub>7</sub>	RAS Low before SDCK Rising Edge	7.2	
SDRAMC <sub>8</sub>	RAS High after SDCK Rising Edge	2.3	
SDRAMC <sub>9</sub>	SDA10 Change before SDCK Rising Edge	7.6	
SDRAMC <sub>10</sub>	SDA10 Change after SDCK Rising Edge	1.9	

**Table 38-28.** SDRAM Clock Signal.

Symbol	Parameter	Min	Units
SDRAMC <sub>11</sub>	Address Change before SDCK Rising Edge	6.2	ns
SDRAMC <sub>12</sub>	Address Change after SDCK Rising Edge	2.2	
SDRAMC <sub>13</sub>	Bank Change before SDCK Rising Edge	6.3	
SDRAMC <sub>14</sub>	Bank Change after SDCK Rising Edge	2.4	
SDRAMC <sub>15</sub>	CAS Low before SDCK Rising Edge	7.4	
SDRAMC <sub>16</sub>	CAS High after SDCK Rising Edge	1.9	
SDRAMC <sub>17</sub>	DQM Change before SDCK Rising Edge	6.4	
SDRAMC <sub>18</sub>	DQM Change after SDCK Rising Edge	2.2	
SDRAMC <sub>19</sub>	D0-D15 in Setup before SDCK Rising Edge	9	
SDRAMC <sub>20</sub>	D0-D15 in Hold after SDCK Rising Edge	0	
SDRAMC <sub>23</sub>	SDWE Low before SDCK Rising Edge	7.6	
SDRAMC <sub>24</sub>	SDWE High after SDCK Rising Edge	1.8	
SDRAMC <sub>25</sub>	D0-D15 Out Valid before SDCK Rising Edge	7.1	
SDRAMC <sub>26</sub>	D0-D15 Out Valid after SDCK Rising Edge	1.5	

Figure 38-4. SDRAMC Signals relative to SDCK.

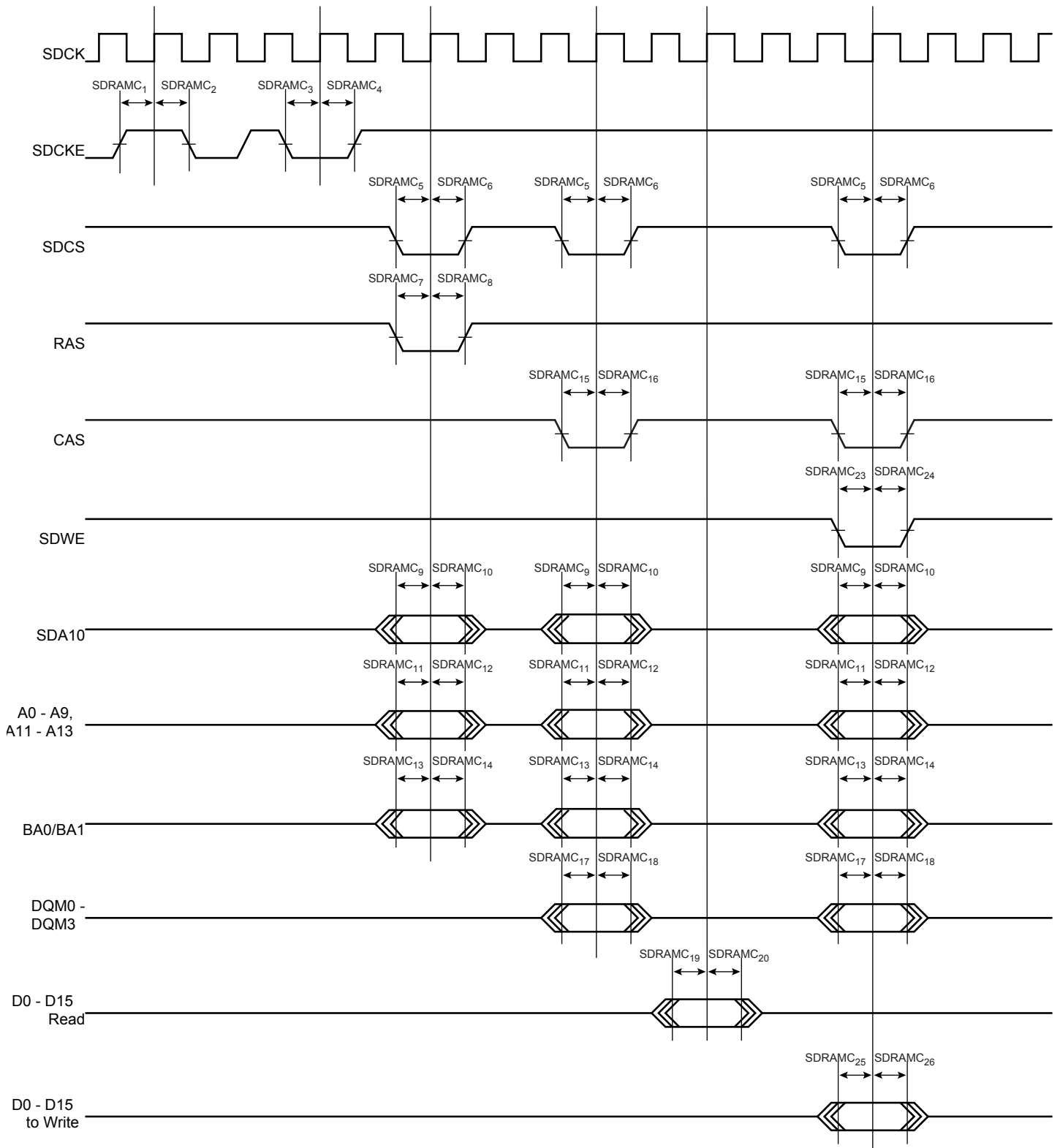

## 38.10 JTAG Timings

### 38.10.1 JTAG Interface Signals

**Table 38-29.** JTAG Interface Timing specification

Symbol	Parameter	Conditions	Min	Max	Units
JTAG <sub>0</sub>	TCK Low Half-period	(1)	6		ns
JTAG <sub>1</sub>	TCK High Half-period	(1)	3		ns
JTAG <sub>2</sub>	TCK Period	(1)	9		ns
JTAG <sub>3</sub>	TDI, TMS Setup before TCK High	(1)	1		ns
JTAG <sub>4</sub>	TDI, TMS Hold after TCK High	(1)	0		ns
JTAG <sub>5</sub>	TDO Hold Time	(1)	4		ns
JTAG <sub>6</sub>	TCK Low to TDO Valid	(1)		6	ns
JTAG <sub>7</sub>	Device Inputs Setup Time	(1)			ns
JTAG <sub>8</sub>	Device Inputs Hold Time	(1)			ns
JTAG <sub>9</sub>	Device Outputs Hold Time	(1)			ns
JTAG <sub>10</sub>	TCK to Device Outputs Valid	(1)			ns

Note: 1.  $V_{DDIO}$  from 3.0V to 3.6V, maximum external capacitor = 40pF

Figure 38-5. JTAG Interface Signals

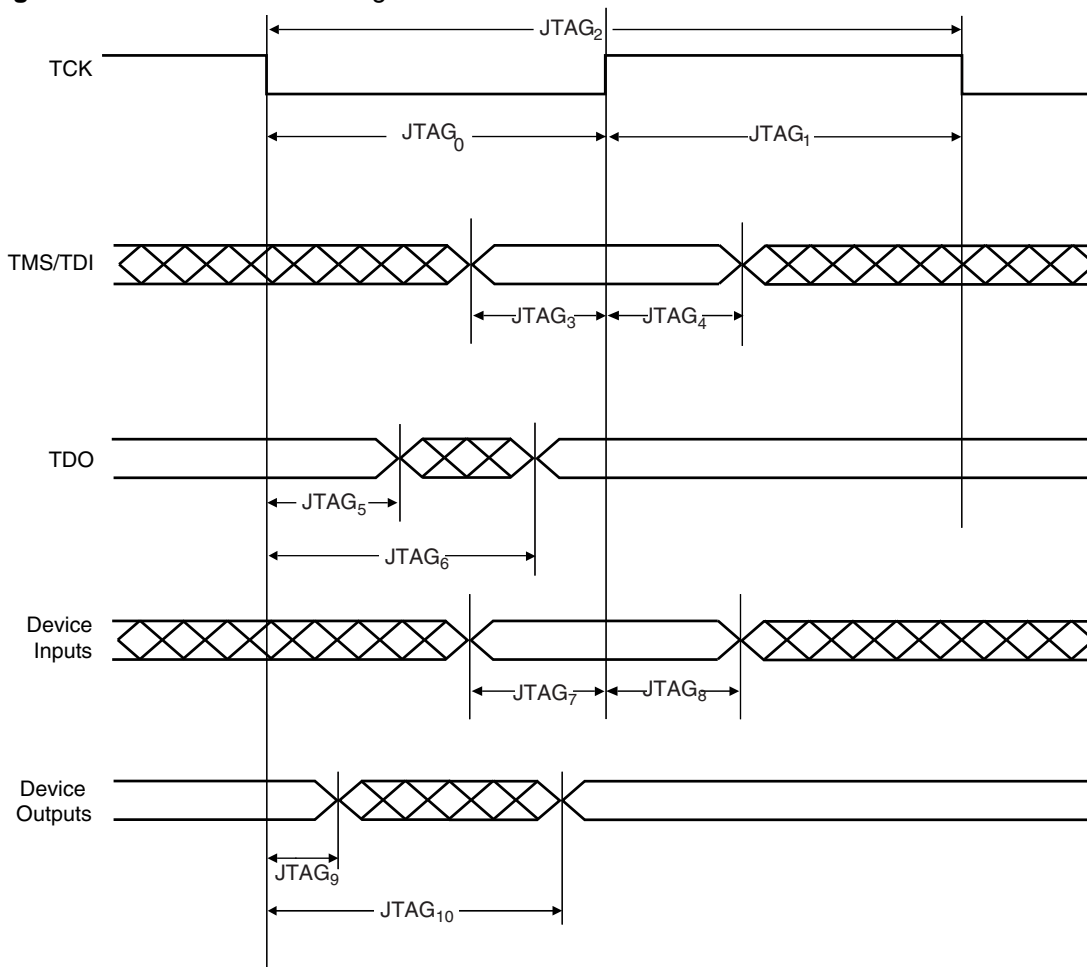

### 38.11 SPI Characteristics

Figure 38-6. SPI Master mode with (CPOL = NCPHA = 0) or (CPOL= NCPHA= 1)

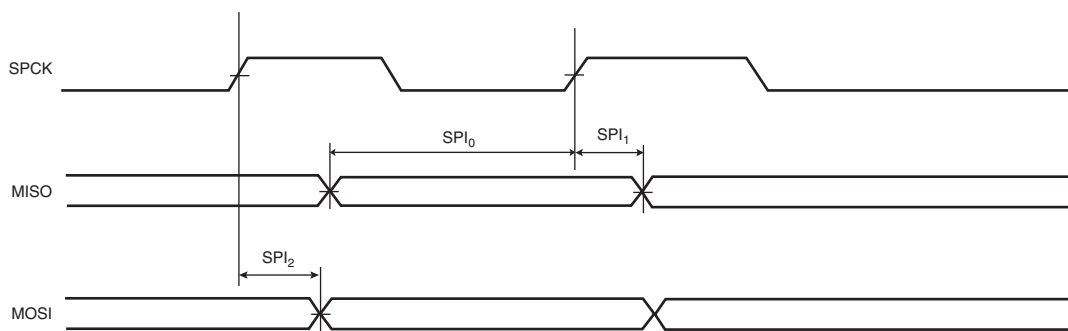

**Figure 38-7.** SPI Master mode with (CPOL=0 and NCPHA=1) or (CPOL=1 and NCPHA=0)

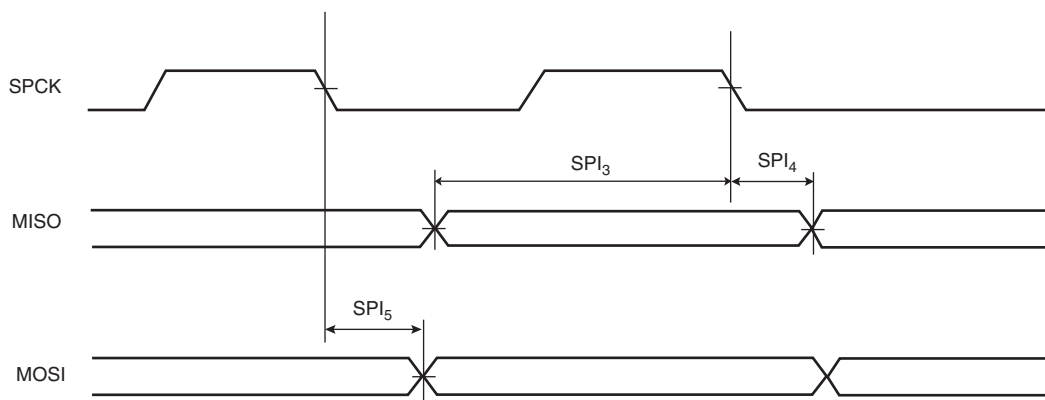

**Figure 38-8.** SPI Slave mode with (CPOL=0 and NCPHA=1) or (CPOL=1 and NCPHA=0)

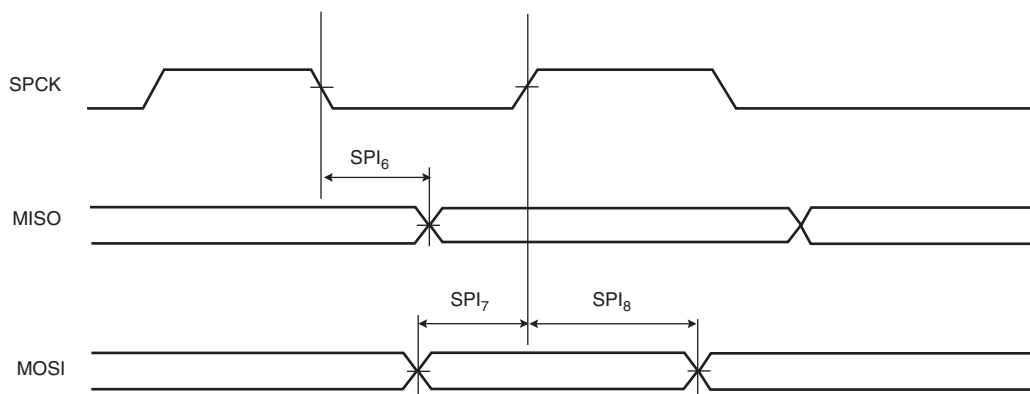

**Figure 38-9.** SPI Slave mode with (CPOL = NCPHA = 0) or (CPOL= NCPHA= 1)

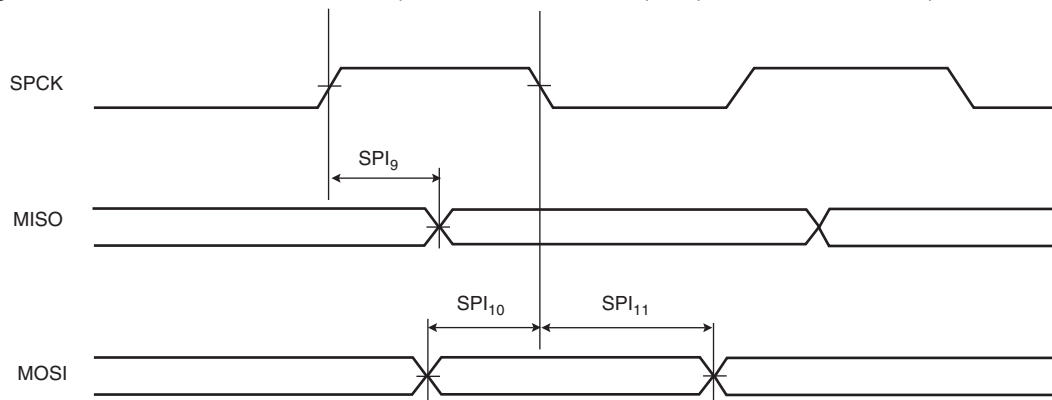

**Table 38-30.** SPI Timings

Symbol	Parameter	Conditions	Min	Max	Units
SPI <sub>0</sub>	MISO Setup time before SPCK rises (master)	3.3V domain <sup>(1)</sup>	22 + (t <sub>CPMCK</sub> )/2 <sup>(2)</sup>		ns
SPI <sub>1</sub>	MISO Hold time after SPCK rises (master)	3.3V domain <sup>(1)</sup>	0		ns
SPI <sub>2</sub>	SPCK rising to MOSI Delay (master)	3.3V domain <sup>(1)</sup>		7	ns
SPI <sub>3</sub>	MISO Setup time before SPCK falls (master)	3.3V domain <sup>(1)</sup>	22 + (t <sub>CPMCK</sub> )/2 <sup>(2)</sup>		ns
SPI <sub>4</sub>	MISO Hold time after SPCK falls (master)	3.3V domain <sup>(1)</sup>	0		ns
SPI <sub>5</sub>	SPCK falling to MOSI Delay (master)	3.3V domain <sup>(1)</sup>		7	ns
SPI <sub>6</sub>	SPCK falling to MISO Delay (slave)	3.3V domain <sup>(1)</sup>		26.5	ns
SPI <sub>7</sub>	MOSI Setup time before SPCK rises (slave)	3.3V domain <sup>(1)</sup>	0		ns
SPI <sub>8</sub>	MOSI Hold time after SPCK rises (slave)	3.3V domain <sup>(1)</sup>	1.5		ns
SPI <sub>9</sub>	SPCK rising to MISO Delay (slave)	3.3V domain <sup>(1)</sup>		27	ns
SPI <sub>10</sub>	MOSI Setup time before SPCK falls (slave)	3.3V domain <sup>(1)</sup>	0		ns
SPI <sub>11</sub>	MOSI Hold time after SPCK falls (slave)	3.3V domain <sup>(1)</sup>	1		ns

Notes: 1. 3.3V domain: V<sub>VDDIO</sub> from 3.0V to 3.6V, maximum external capacitor = 40 pF.  
 2. t<sub>CPMCK</sub>: Master Clock period in ns.

## 38.12 MACB Characteristics

**Table 38-31.** Ethernet MAC Signals

Symbol	Parameter	Conditions	Min (ns)	Max (ns)
EMAC <sub>1</sub>	Setup for EMDIO from EMDC rising	Load: 20pF <sup>(2)</sup>		
EMAC <sub>2</sub>	Hold for EMDIO from EMDC rising	Load: 20pF <sup>(2)</sup>		
EMAC <sub>3</sub>	EMDIO toggling from EMDC falling	Load: 20pF <sup>(2)</sup>		

Notes: 1. f: MCK frequency (MHz)  
 2. V<sub>VDDIO</sub> from 3.0V to 3.6V, maximum external capacitor = 20 pF

**Table 38-32.** Ethernet MAC MII Specific Signals

Symbol	Parameter	Conditions	Min (ns)	Max (ns)
EMAC <sub>4</sub>	Setup for ECOL from ETXCK rising	Load: 20pF <sup>(1)</sup>	3	
EMAC <sub>5</sub>	Hold for ECOL from ETXCK rising	Load: 20pF <sup>(1)</sup>	0	
EMAC <sub>6</sub>	Setup for ECRS from ETXCK rising	Load: 20pF <sup>(1)</sup>	3	
EMAC <sub>7</sub>	Hold for ECRS from ETXCK rising	Load: 20pF <sup>(1)</sup>	0	
EMAC <sub>8</sub>	ETXER toggling from ETXCK rising	Load: 20pF <sup>(1)</sup>		15
EMAC <sub>9</sub>	ETXEN toggling from ETXCK rising	Load: 20pF <sup>(1)</sup>		15
EMAC <sub>10</sub>	ETX toggling from ETXCK rising	Load: 20pF <sup>(1)</sup>		15
EMAC <sub>11</sub>	Setup for ERX from ERXCK	Load: 20pF <sup>(1)</sup>	1	

**Table 38-32.** Ethernet MAC MII Specific Signals

Symbol	Parameter	Conditions	Min (ns)	Max (ns)
EMAC <sub>12</sub>	Hold for ERX from ERXCK	Load: 20pF <sup>(1)</sup>	1.5	
EMAC <sub>13</sub>	Setup for ERXER from ERXCK	Load: 20pF <sup>(1)</sup>	1	
EMAC <sub>14</sub>	Hold for ERXER from ERXCK	Load: 20pF <sup>(1)</sup>	0.5	
EMAC <sub>15</sub>	Setup for ERXDV from ERXCK	Load: 20pF <sup>(1)</sup>	1.5	
EMAC <sub>16</sub>	Hold for ERXDV from ERXCK	Load: 20pF <sup>(1)</sup>	1	

Note: 1. V<sub>VDDIO</sub> from 3.0V to 3.6V, maximum external capacitor = 20 pF

**Figure 38-10.** Ethernet MAC MII Mode

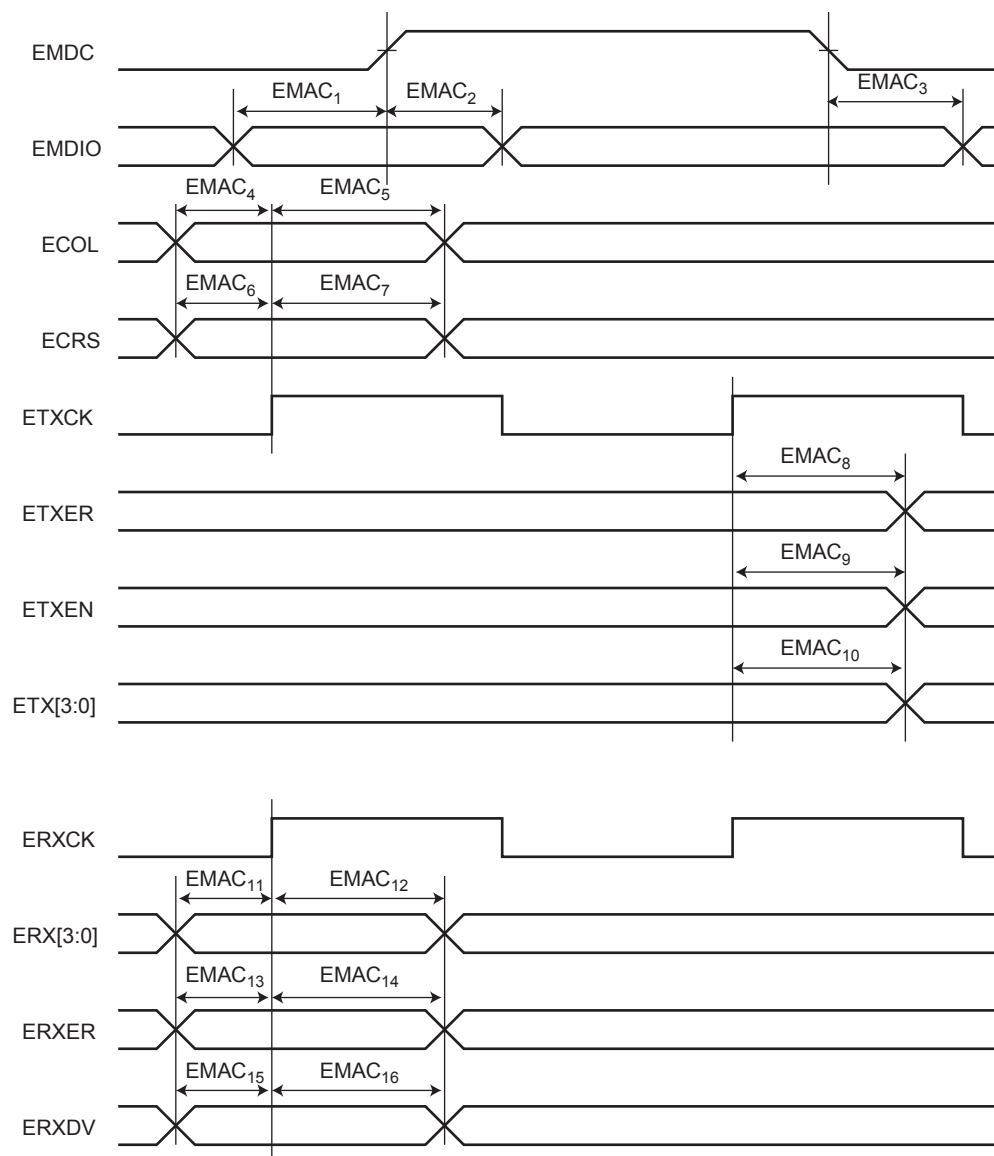
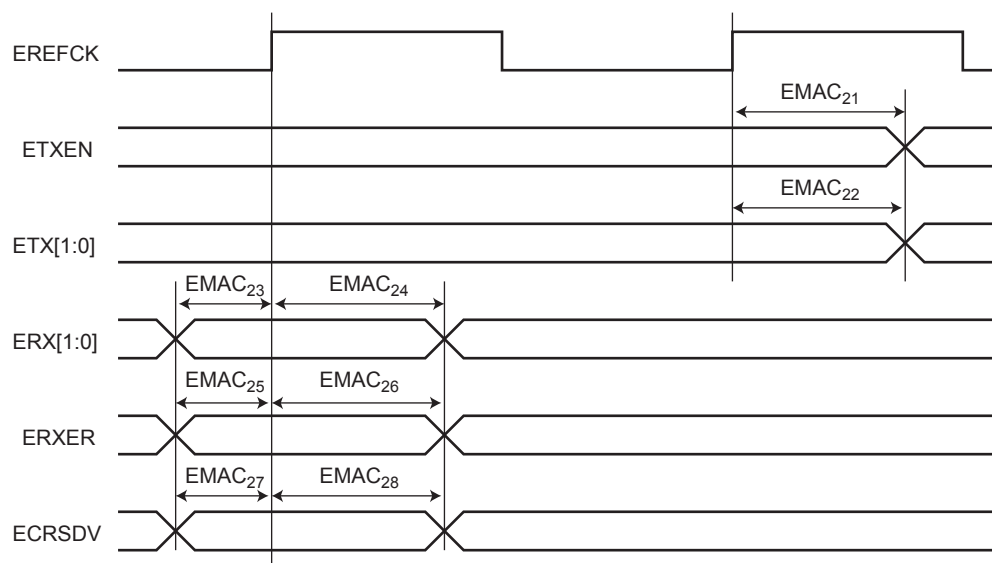



**Table 38-33.** Ethernet MAC RMII Specific Signals

Symbol	Parameter	Min (ns)	Max (ns)
EMAC <sub>21</sub>	ETXEN toggling from EREFCK rising	7	14.5
EMAC <sub>22</sub>	ETX toggling from EREFCK rising	7	14.7
EMAC <sub>23</sub>	Setup for ERX from EREFCK	1.5	
EMAC <sub>24</sub>	Hold for ERX from EREFCK	0	
EMAC <sub>25</sub>	Setup for ERXER from EREFCK	1.5	
EMAC <sub>26</sub>	Hold for ERXER from EREFCK	0	
EMAC <sub>27</sub>	Setup for ECRSDV from EREFCK	1.5	
EMAC <sub>28</sub>	Hold for ECRSDV from EREFCK	0	

**Figure 38-11.** Ethernet MAC RMII Mode



### 38.13 Flash Characteristics

The following table gives the device maximum operating frequency depending on the field FWS of the Flash FSR register. This field defines the number of wait states required to access the Flash Memory.

**Table 38-34.** Flash Wait States

FWS	Read Operations	Maximum Operating Frequency (MHz)
0	1 cycle	33
1	2 cycles	66

Table 38-35. Programming Time

Temperature Operating Range Part	Page Programming Time (ms)	Chip Erase Time (ms)
Industrial	4	4
Automotive	16	16

## 39. Mechanical Characteristics

### 39.1 Thermal Considerations

#### 39.1.1 Thermal Data

Table 39-1 summarizes the thermal resistance data depending on the package.

**Table 39-1.** Thermal Resistance Data

Symbol	Parameter	Condition	Package	Typ	Unit
$\theta_{JA}$	Junction-to-ambient thermal resistance	Still Air	TQFP100	43.4	.C/W
$\theta_{JC}$	Junction-to-case thermal resistance		TQFP100	5.5	
$\theta_{JA}$	Junction-to-ambient thermal resistance	Still Air	LQFP144	39.8	.C/W
$\theta_{JC}$	Junction-to-case thermal resistance		LQFP144	8.9	

#### 39.1.2 Junction Temperature

The average chip-junction temperature,  $T_J$ , in °C can be obtained from the following:

1.  $T_J = T_A + (P_D \times \theta_{JA})$
2.  $T_J = T_A + (P_D \times (\theta_{HEATSINK} + \theta_{JC}))$

where:

- $\theta_{JA}$  = package thermal resistance, Junction-to-ambient (°C/W), provided in [Table 39-1 on page 787](#).
- $\theta_{JC}$  = package thermal resistance, Junction-to-case thermal resistance (°C/W), provided in [Table 39-1 on page 787](#).
- $\theta_{HEAT\ SINK}$  = cooling device thermal resistance (°C/W), provided in the device datasheet.
- $P_D$  = device power consumption (W) estimated from data provided in the section "[Power Consumption](#)" on page 767.
- $T_A$  = ambient temperature (°C).

From the first equation, the user can derive the estimated lifetime of the chip and decide if a cooling device is necessary or not. If a cooling device is to be fitted on the chip, the second equation should be used to compute the resulting average chip-junction temperature  $T_J$  in °C.

## 39.2 Package Drawings

Figure 39-1. TQFP-100 package drawing

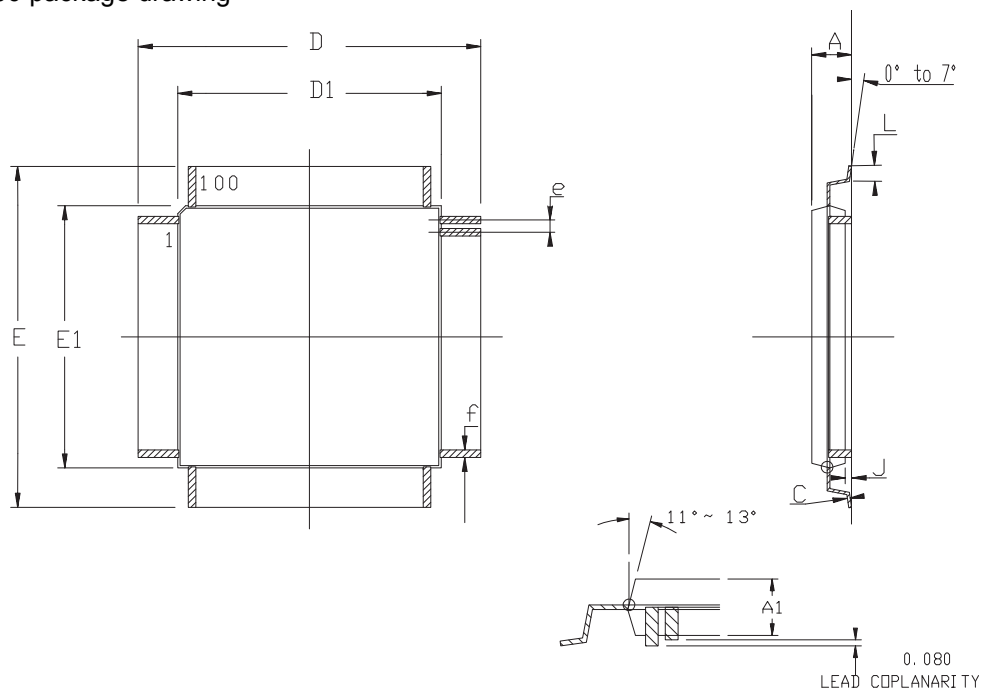

	MM		INCH	
	Min	Max	Min	Max
A	----	1.20	----	.047
A1	0.95	1.05	.037	.041
C	0.09	0.20	.004	.008
D	16.00 BSC		.630 BSC	
D1	14.00 BSC		.551 BSC	
E	16.00 BSC		.630 BSC	
E1	14.00 BSC		.551 BSC	
J	0.05	0.15	.002	.006
L	0.45	0.75	.018	.030
e	0.50 BSC		.020 BSC	
f	0.17	0.27	.007	.011

Table 39-2. Device and Package Maximum Weight

500	mg
-----	----

Table 39-3. Package Characteristics

Moisture Sensitivity Level	Jdec J-STD0-20D - MSL 3
----------------------------	-------------------------

Table 39-4. Package Reference

JEDEC Drawing Reference	MS-026
JESD97 Classification	E3

**Figure 39-2.** LQFP-144 package drawing

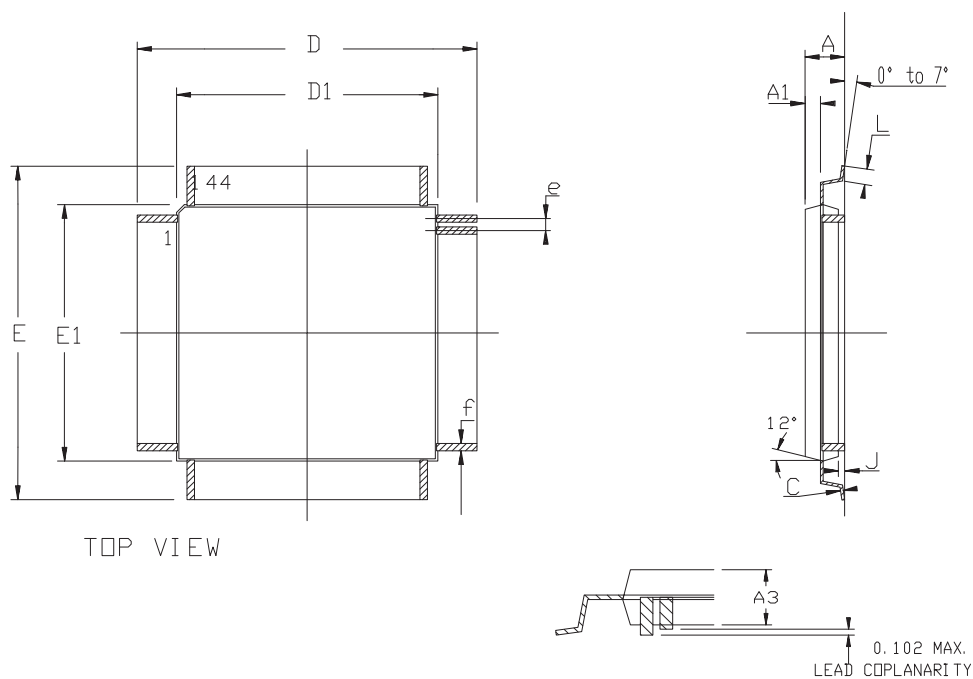

	MM		INCH	
	Min	Max	Min	Max
A	-	1.60	-	.063
C	0.09	0.20	.004	.008
A3	1.35	1.45	.053	.057
D	21.90	22.10	.862	.870
D1	19.90	20.10	.783	.791
E	21.90	22.10	.862	.870
E1	19.90	20.10	.783	.791
J	0.05	0.15	.002	.006
L	0.45	0.75	.018	.030
e	0.50 BSC		.0197 BSC	
f	0.22 BSC		.009 BSC	

**Table 39-5.** Device and Package Maximum Weight

1300	mg
------	----

**Table 39-6.** Package Characteristics

Moisture Sensitivity Level	Jdec J-STD0-20D - MSL 3
----------------------------	-------------------------

**Table 39-7.** Package Reference

JEDEC Drawing Reference	MS-026
JESD97 Classification	E3

**Figure 39-3.** FFBGA-144 package drawing

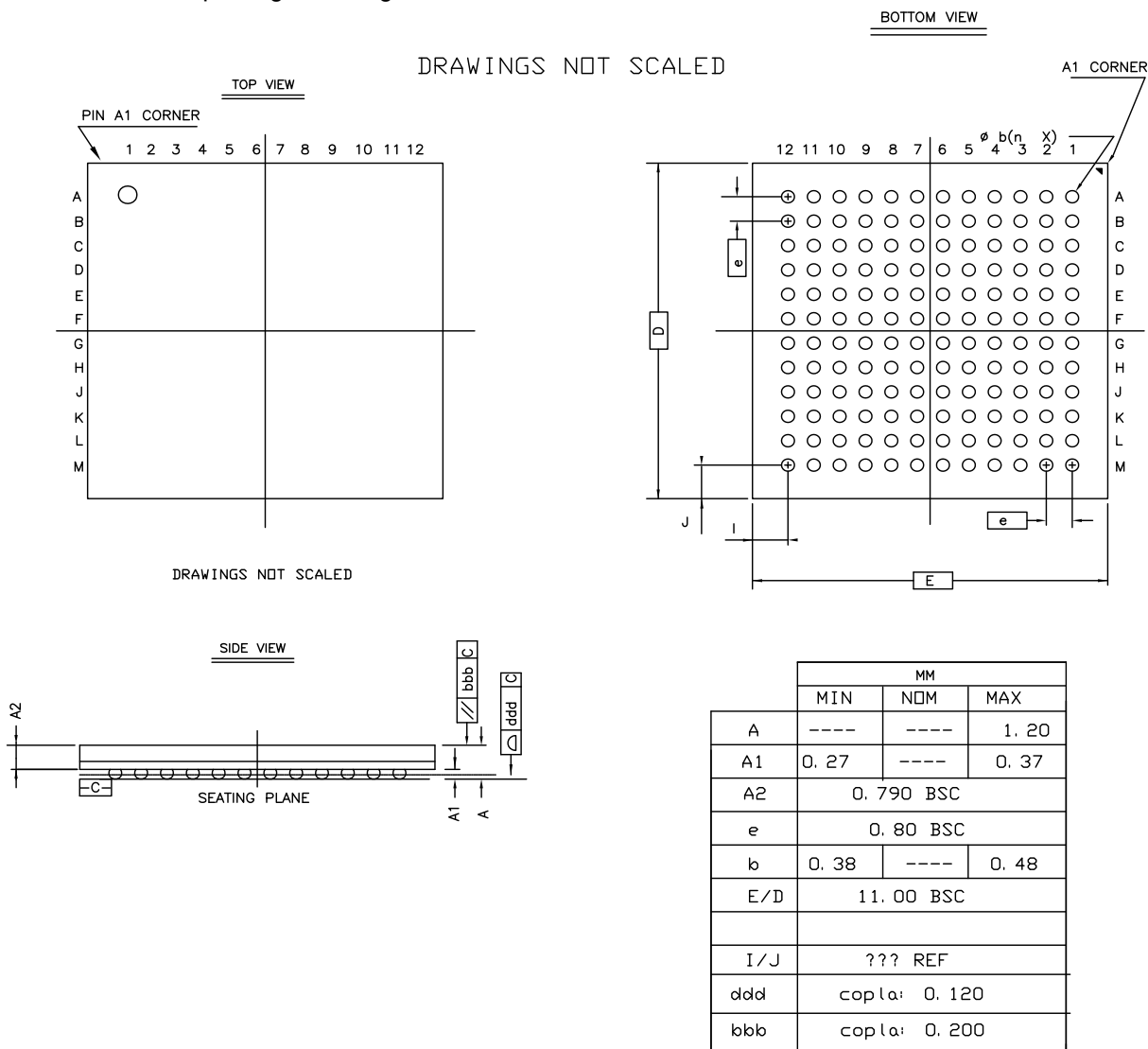

**Table 39-8.** Device and Package Maximum Weight

1300	mg
------	----

**Table 39-9.** Package Characteristics

Moisture Sensitivity Level	MSL3
----------------------------	------

**Table 39-10.** Package Reference

JEDEC Drawing Reference	MS-026
JESD97 Classification	E3

### 39.3 Soldering Profile

Table 39-11 gives the recommended soldering profile from J-STD-20.

**Table 39-11.** Soldering Profile

Profile Feature	Green Package
Average Ramp-up Rate (217°C to Peak)	3°C/sec
Preheat Temperature 175°C ±25°C	Min. 150 °C, Max. 200 °C
Time Maintained Above 217°C	60-150 sec
Time within 5-C of Actual Peak Temperature	30 sec
Peak Temperature Range	260 °C
Ramp-down Rate	6 °C/sec
Time 25-C to Peak Temperature	Max. 8 minutes

Note: It is recommended to apply a soldering temperature higher than 250°C. A maximum of three reflow passes is allowed per component.

## 40. Ordering Information

Table 40-1. Ordering Information

Device	Ordering Code	Package	Conditioning	Temperature Operating Range
<b>AT32UC3A0512</b>	AT32UC3A0512-ALUT	144 LQFP	Tray	Industrial (-40-C to 85-C)
	AT32UC3A0512-ALUR	144 LQFP	Reel	Industrial (-40-C to 85-C)
	AT32UC3A0512-ALTRA	144 LQFP	Reel	Automotive (-40-C to 85-C)
	AT32UC3A0512-ALTTA	144 LQFP	Tray	Automotive (-40-C to 85-C)
	AT32UC3A0512-CTUT	144 FFBGA	Tray	Industrial (-40-C to 85-C)
	AT32UC3A0512-CTUR	144 FFBGA	Reel	Industrial (-40-C to 85-C)
<b>AT32UC3A0256</b>	AT32UC3A0256-ALUT	144 LQFP	Tray	Industrial (-40-C to 85-C)
	AT32UC3A0256-ALUR	144 LQFP	Reel	Industrial (-40-C to 85-C)
	AT32UC3A0256-CTUT	144 FFBGA	Tray	Industrial (-40-C to 85-C)
	AT32UC3A0256-CTUR	144 FFBGA	Reel	Industrial (-40-C to 85-C)
<b>AT32UC3A0128</b>	AT32UC3A0128-ALUT	144 LQFP	Tray	Industrial (-40-C to 85-C)
	AT32UC3A0128-ALUR	144 LQFP	Reel	Industrial (-40-C to 85-C)
	AT32UC3A0128-CTUT	144 FFBGA	Tray	Industrial (-40-C to 85-C)
	AT32UC3A0128-CTUR	144 FFBGA	Reel	Industrial (-40-C to 85-C)
<b>AT32UC3A1512</b>	AT32UC3A1512-AUT	100 TQFP	Tray	Industrial (-40-C to 85-C)
	AT32UC3A1512-AUR	100 TQFP	Reel	Industrial (-40-C to 85-C)
<b>AT32UC3A1256</b>	AT32UC3A1256-AUT	100 TQFP	Tray	Industrial (-40-C to 85-C)
	AT32UC3A1256-AUR	100 TQFP	Reel	Industrial (-40-C to 85-C)
<b>AT32UC3A1128</b>	AT32UC3A1128-AUT	100 TQFP	Tray	Industrial (-40-C to 85-C)
	AT32UC3A1128-AUR	100 TQFP	Reel	Industrial (-40-C to 85-C)

### 40.1 Automotive Quality Grade

The AT32UC3A have been developed and manufactured according to the most stringent requirements of the international standard ISO-TS-16949. This data sheet will contain limit values extracted from the results of extensive characterization (Temperature and Voltage). The quality and reliability of the AT32UC3A is verified during regular product qualification as per AEC-Q100 grade 3.

As indicated in the ordering information paragraph, the product is available in only one temperature grade T: -40°C / + 85°C.



## 41. Errata

All industrial parts labelled with -UES (engineering samples) are revision E parts.  
All automotive parts labelled with AT32UC3A0512-ALTRA or AT32UC3A0512-ALTTA are revision K parts.

### 41.1 Rev. K, L, M

#### 41.1.1 PWM

##### 1. PWM channel interrupt enabling triggers an interrupt

When enabling a PWM channel that is configured with center aligned period (CALG=1), an interrupt is signalled.

##### Fix/Workaround

When using center aligned mode, enable the channel and read the status before channel interrupt is enabled.

##### 2. PWM counter restarts at 0x0001

The PWM counter restarts at 0x0001 and not 0x0000 as specified. Because of this the first PWM period has one more clock cycle.

##### Fix/Workaround

- The first period is 0x0000, 0x0001, ..., period
- Consecutive periods are 0x0001, 0x0002, ..., period

##### 3. PWM update period to a 0 value does not work

It is impossible to update a period equal to 0 by the using the PWM update register (PWM\_CUPD).

##### Fix/Workaround

Do not update the PWM\_CUPD register with a value equal to 0.

#### 41.1.2 ADC

##### 1. Sleep Mode activation needs additional A to D conversion

If the ADC sleep mode is activated when the ADC is idle the ADC will not enter sleep mode before after the next AD conversion.

##### Fix/Workaround

Activate the sleep mode in the mode register and then perform an AD conversion.

#### 41.1.3 SPI

##### 1. SPI Slave / PDCA transfer: no TX UNDERRUN flag

There is no TX UNDERRUN flag available, therefore in SPI slave mode, there is no way to be informed of a character lost in transmission.

##### Fix/Workaround

For PDCA transfer: none.

##### 2. SPI FDIV option does not work

Selecting clock signal using FDIV = 1 does not work as specified.

##### Fix/Workaround

Do not set FDIV = 1.

### 3. SPI Bad Serial Clock Generation on 2nd chip\_select when SCBR = 1, CPOL=1 and NCPHA=0

When multiple CS are in use, if one of the baudrate equals to 1 and one of the others doesn't equal to 1, and CPOL=1 and CPHA=0, then an additional pulse will be generated on SCK.

#### Fix/workaround

When multiple CS are in use, if one of the baudrate equals 1, the other must also equal 1 if CPOL=1 and CPHA=0.

### 4. SPI Glitch on RXREADY flag in slave mode when enabling the SPI or during the first transfer

In slave mode, the SPI can generate a false RXREADY signal during enabling of the SPI or during the first transfer.

#### Fix/Workaround

1. Set slave mode, set required CPOL/CPHA.
2. Enable SPI.
3. Set the polarity CPOL of the line in the opposite value of the required one.
4. Set the polarity CPOL to the required one.
5. Read the RXHOLDING register.

Transfers can now begin and RXREADY will now behave as expected.

### 5. SPI Disable does not work in Slave mode

#### Fix/workaround

Read the last received data then perform a Software reset.

## 41.1.4 Power Manager

### 1. If the BOD level is higher than VDDCORE, the part is constantly under reset

If the BOD level is set to a value higher than VDDCORE and enabled by fuses, the part will be in constant reset.

#### Fix/Workaround

Apply an external voltage on VDDCORE that is higher than the BOD level and is lower than VDDCORE max and disable the BOD.

## 41.1.5 PDCA

### 1. Wrong PDCA behavior when using two PDCA channels with the same PID.

#### Fix/Workaround

The same PID should not be assigned to more than one channel.

## 41.1.6 TWI

### 1. The TWI RXRDY flag in SR register is not reset when a software reset is performed.

#### Fix/Workaround

After a Software Reset, the register TWI RHR must be read.

## 41.1.7 USART

### 1. ISO7816 info register US\_NER cannot be read

The NER register always returns zero.

#### Fix/Workaround

None

## 41.1.8 Processor and Architecture

### 1. LDM instruction with PC in the register list and without ++ increments Rp

For LDM with PC in the register list: the instruction behaves as if the ++ field is always set, ie the pointer is always updated. This happens even if the ++ field is cleared. Specifically, the increment of the pointer is done in parallel with the testing of R12.

**Fix/Workaround**

None.

#### 41.1.9 FLASHC

**1. Reading from on-chip flash may fail after a flash fuse write operation (FLASHC LP, UP, WGPB, EGPB, SSB, PGPFB, EAGPF commands).**

After a flash fuse write operation (FLASHC LP, UP, WGPB, EGPB, SSB, PGPFB, EAGPF commands), the following flash read access may return corrupted data. This erratum does not affect write operations to regular flash memory.

**Fix/Workaround**

The flash fuse write operation (FLASHC LP, UP, WGPB, EGPB, SSB, PGPFB, EAGPF commands) must be issued from internal RAM. After the write operation, perform a dummy flash page write operation (FLASHC WP). Content and location of this page is not important and filling the write buffer with all one (FFh) will leave the current flash content unchanged. It is then safe to read and fetch code from the flash.

## 41.2 Rev. J

### 41.2.1 PWM

#### 1. PWM channel interrupt enabling triggers an interrupt

When enabling a PWM channel that is configured with center aligned period (CALG=1), an interrupt is signalled.

##### Fix/Workaround

When using center aligned mode, enable the channel and read the status before channel interrupt is enabled.

#### 2. PWM counter restarts at 0x0001

The PWM counter restarts at 0x0001 and not 0x0000 as specified. Because of this the first PWM period has one more clock cycle.

##### Fix/Workaround

- The first period is 0x0000, 0x0001, ..., period
- Consecutive periods are 0x0001, 0x0002, ..., period

#### 3. PWM update period to a 0 value does not work

It is impossible to update a period equal to 0 by the using the PWM update register (PWM\_CUPD).

##### Fix/Workaround

Do not update the PWM\_CUPD register with a value equal to 0.

### 41.2.2 ADC

#### 1. Sleep Mode activation needs additional A to D conversion

If the ADC sleep mode is activated when the ADC is idle the ADC will not enter sleep mode before after the next AD conversion.

##### Fix/Workaround

Activate the sleep mode in the mode register and then perform an AD conversion.

### 41.2.3 SPI

#### 1. SPI Slave / PDCA transfer: no TX UNDERRUN flag

There is no TX UNDERRUN flag available, therefore in SPI slave mode, there is no way to be informed of a character lost in transmission.

##### Fix/Workaround

For PDCA transfer: none.

#### 2. SPI FDIV option does not work

Selecting clock signal using FDIV = 1 does not work as specified.

##### Fix/Workaround

Do not set FDIV = 1.

#### 3. SPI Bad Serial Clock Generation on 2nd chip\_select when SCBR = 1, CPOL=1 and NCPHA=0

When multiple CS are in use, if one of the baudrate equals to 1 and one of the others doesn't equal to 1, and CPOL=1 and CPHA=0, then an additional pulse will be generated on SCK.

##### Fix/workaround

When multiple CS are in use, if one of the baudrate equals 1, the other must also equal 1 if CPOL=1 and CPHA=0.

**4. SPI Glitch on RXREADY flag in slave mode when enabling the SPI or during the first transfer**

In slave mode, the SPI can generate a false RXREADY signal during enabling of the SPI or during the first transfer.

**Fix/Workaround**

1. Set slave mode, set required CPOL/CPHA.
2. Enable SPI.
3. Set the polarity CPOL of the line in the opposite value of the required one.
4. Set the polarity CPOL to the required one.
5. Read the RXHOLDING register.

Transfers can now begin and RXREADY will now behave as expected.

**5. SPI Disable does not work in Slave mode**

**Fix/workaround**

Read the last received data then perform a Software reset.

## 41.2.4 Power Manager

**1. If the BOD level is higher than VDDCORE, the part is constantly under reset**

If the BOD level is set to a value higher than VDDCORE and enabled by fuses, the part will be in constant reset.

**Fix/Workaround**

Apply an external voltage on VDDCORE that is higher than the BOD level and is lower than VDDCORE max and disable the BOD.

## 41.2.5 PDCA

**1. Wrong PDCA behavior when using two PDCA channels with the same PID.**

**Fix/Workaround**

The same PID should not be assigned to more than one channel.

## 41.2.6 TWI

**1. The TWI RXRDY flag in SR register is not reset when a software reset is performed.**

**Fix/Workaround**

After a Software Reset, the register TWI RHR must be read.

## 41.2.7 SDRAMC

**1. Code execution from external SDRAM does not work**

Code execution from SDRAM does not work.

**Fix/Workaround**

Do not run code from SDRAM.

## 41.2.8 GPIO

**1. PA29 (TWI SDA) and PA30 (TWI SCL) GPIO VIH (input high voltage) is 3.6V max instead of 5V tolerant**

The following GPIOs are not 5V tolerant : PA29 and PA30.

**Fix/Workaround**

## 41.2.9 USART

None.

1. **ISO7816 info register US\_NER cannot be read**

The NER register always returns zero.

**Fix/Workaround**

None

## 41.2.10 Processor and Architecture

1. **LDM instruction with PC in the register list and without ++ increments Rp**

For LDM with PC in the register list: the instruction behaves as if the ++ field is always set, ie the pointer is always updated. This happens even if the ++ field is cleared. Specifically, the increment of the pointer is done in parallel with the testing of R12.

**Fix/Workaround**

None.

2. **RETE instruction does not clear SREG[L] from interrupts.**

The RETE instruction clears SREG[L] as expected from exceptions.

**Fix/Workaround**

When using the STCOND instruction, clear SREG[L] in the stacked value of SR before returning from interrupts with RETE.

3. **Exceptions when system stack is protected by MPU**

RETS behaves incorrectly when MPU is enabled and MPU is configured so that system stack is not readable in unprivileged mode.

**Fix/Woraround**

Workaround 1: Make system stack readable in unprivileged mode,  
or

Workaround 2: Return from supervisor mode using rete instead of rets. This requires :

1. Changing the mode bits from 001b to 110b before issuing the instruction. Updating the mode bits to the desired value must be done using a single mt-sr instruction so it is done atomically. Even if this step is described in general as not safe in the UC technical reference guide, it is safe in this very specific case.
2. Execute the RETE instruction.

## 41.2.11 FLASHC

1. **Reading from on-chip flash may fail after a flash fuse write operation (FLASHC LP, UP, WGPB, EGPB, SSB, PGPFB, EAGPF commands).**

After a flash fuse write operation (FLASHC LP, UP, WGPB, EGPB, SSB, PGPFB, EAGPF commands), the following flash read access may return corrupted data. This erratum does not affect write operations to regular flash memory.

**Fix/Workaround**

The flash fuse write operation (FLASHC LP, UP, WGPB, EGPB, SSB, PGPFB, EAGPF commands) must be issued from internal RAM. After the write operation, perform a dummy flash page write operation (FLASHC WP). Content and location of this page is not important and filling the write buffer with all one (FFh) will leave the current flash content unchanged. It is then safe to read and fetch code from the flash.

## 41.3 Rev. I

### 41.3.1 PWM

#### 1. PWM channel interrupt enabling triggers an interrupt

When enabling a PWM channel that is configured with center aligned period (CALG=1), an interrupt is signalled.

##### Fix/Workaround

When using center aligned mode, enable the channel and read the status before channel interrupt is enabled.

#### 2. PWM counter restarts at 0x0001

The PWM counter restarts at 0x0001 and not 0x0000 as specified. Because of this the first PWM period has one more clock cycle.

##### Fix/Workaround

- The first period is 0x0000, 0x0001, ..., period
- Consecutive periods are 0x0001, 0x0002, ..., period

#### 3. PWM update period to a 0 value does not work

It is impossible to update a period equal to 0 by the using the PWM update register (PWM\_CUPD).

##### Fix/Workaround

Do not update the PWM\_CUPD register with a value equal to 0.

### 41.3.2 ADC

#### 1. Sleep Mode activation needs additional A to D conversion

If the ADC sleep mode is activated when the ADC is idle the ADC will not enter sleep mode before after the next AD conversion.

##### Fix/Workaround

Activate the sleep mode in the mode register and then perform an AD conversion.

### 41.3.3 SPI

#### 1. SPI Slave / PDCA transfer: no TX UNDERRUN flag

There is no TX UNDERRUN flag available, therefore in SPI slave mode, there is no way to be informed of a character lost in transmission.

##### Fix/Workaround

For PDCA transfer: none.

#### 2. SPI FDIV option does not work

Selecting clock signal using FDIV = 1 does not work as specified.

##### Fix/Workaround

Do not set FDIV = 1.

#### 3. SPI Bad Serial Clock Generation on 2nd chip\_select when SCBR = 1, CPOL=1 and NCPHA=0

When multiple CS are in use, if one of the baudrate equals to 1 and one of the others doesn't equal to 1, and CPOL=1 and CPHA=0, then an additional pulse will be generated on SCK.

##### Fix/workaround

When multiple CS are in use, if one of the baudrate equals 1, the other must also equal 1 if CPOL=1 and CPHA=0.

#### 4. **SPI Glitch on RXREADY flag in slave mode when enabling the SPI or during the first transfer**

In slave mode, the SPI can generate a false RXREADY signal during enabling of the SPI or during the first transfer.

##### **Fix/Workaround**

1. Set slave mode, set required CPOL/CPHA.
2. Enable SPI.
3. Set the polarity CPOL of the line in the opposite value of the required one.
4. Set the polarity CPOL to the required one.
5. Read the RXHOLDING register.

Transfers can now begin and RXREADY will now behave as expected.

#### 5. **SPI Disable does not work in Slave mode**

##### **Fix/workaround**

Read the last received data then perform a Software reset.

### 41.3.4 Power Manager

#### 1. **If the BOD level is higher than VDDCORE, the part is constantly under reset**

If the BOD level is set to a value higher than VDDCORE and enabled by fuses, the part will be in constant reset.

##### **Fix/Workaround**

Apply an external voltage on VDDCORE that is higher than the BOD level and is lower than VDDCORE max and disable the BOD.

### 41.3.5 Flashc

#### 1. **On AT32UC3A0512 and AT32UC3A1512, corrupted read in flash after FLASHC WP, EP, EA, WUP, EUP commands may happen**

- After a FLASHC Write Page (WP) or Erase Page (EP) command applied to a page in a given half of the flash (first or last 256 kB of flash), reading (data read or code fetch) the other half of the flash may fail. This may lead to an exception or to other errors derived from this corrupted read access.

- After a FLASHC Erase All (EA) command, reading (data read or code fetch) the flash may fail. This may lead to an exception or to other errors derived from this corrupted read access.

- After a FLASHC Write User Page (WUP) or Erase User Page (EUP) command, reading (data read or code fetch) the second half (last 256 kB) of the flash may fail. This may lead to an exception or to other errors derived from this corrupted read access.

##### **Fix/Workaround**

Flashc WP, EP, EA, WUP, EUP commands: these commands must be issued from RAM or through the EBI. After these commands, read twice one flash page initialized to 00h in each half part of the flash.

### 41.3.6 PDCA

#### 1. **Wrong PDCA behavior when using two PDCA channels with the same PID.**



**Workaround/fix**

The same PID should not be assigned to more than one channel.

**41.3.7 GPIO****1. Some GPIO VIH (input high voltage) are 3.6V max instead of 5V tolerant**

Only 11 GPIOs remain 5V tolerant (VIHmax=5V):PB01, PB02, PB03, PB10, PB19, PB20, PB21, PB22, PB23, PB27, PB28.

**Workaround/fix**

None.

**41.3.8 USART****1. ISO7816 info register US\_NER cannot be read**

The NER register always returns zero.

**Fix/Workaround**

None.

**41.3.9 TWI****1. The TWI RXRDY flag in SR register is not reset when a software reset is performed.****Fix/Workaround**

After a Software Reset, the register TWI RHR must be read.

**41.3.10 SDRAMC****1. Code execution from external SDRAM does not work**

Code execution from SDRAM does not work.

**Fix/Workaround**

Do not run code from SDRAM.

**41.3.11 Processor and Architecture****1. LDM instruction with PC in the register list and without ++ increments Rp**

For LDM with PC in the register list: the instruction behaves as if the ++ field is always set, ie the pointer is always updated. This happens even if the ++ field is cleared. Specifically, the increment of the pointer is done in parallel with the testing of R12.

**Fix/Workaround**

None.

**2. RETE instruction does not clear SREG[L] from interrupts.**

The RETE instruction clears SREG[L] as expected from exceptions.

**Fix/Workaround**

When using the STCOND instruction, clear SREG[L] in the stacked value of SR before returning from interrupts with RETE.

**3. Exceptions when system stack is protected by MPU**

RETS behaves incorrectly when MPU is enabled and MPU is configured so that system stack is not readable in unprivileged mode.

**Fix/Woraround**

Workaround 1: Make system stack readable in unprivileged mode,  
or

Workaround 2: Return from supervisor mode using rete instead of rets. This requires :

1. Changing the mode bits from 001b to 110b before issuing the instruction. Updating the mode bits to the desired value must be done using a single mtsr instruction so it is done atomically. Even if this step is described in general as not safe in the UC technical reference guide, it is safe in this very

- specific case.
2. Execute the RETE instruction.

#### 41.3.12 FLASHC

1. **Reading from on-chip flash may fail after a flash fuse write operation (FLASHC LP, UP, WGPB, EGPB, SSB, PGPFB, EAGPF commands).**

After a flash fuse write operation (FLASHC LP, UP, WGPB, EGPB, SSB, PGPFB, EAGPF commands), the following flash read access may return corrupted data. This erratum does not affect write operations to regular flash memory.

**Fix/Workaround**

The flash fuse write operation (FLASHC LP, UP, WGPB, EGPB, SSB, PGPFB, EAGPF commands) must be issued from internal RAM. After the write operation, perform a dummy flash page write operation (FLASHC WP). Content and location of this page is not important and filling the write buffer with all one (FFh) will leave the current flash content unchanged. It is then safe to read and fetch code from the flash.

## 41.4 Rev. H

### 41.4.1 PWM

#### 1. PWM channel interrupt enabling triggers an interrupt

When enabling a PWM channel that is configured with center aligned period (CALG=1), an interrupt is signalled.

##### Fix/Workaround

When using center aligned mode, enable the channel and read the status before channel interrupt is enabled.

#### 2. PWM counter restarts at 0x0001

The PWM counter restarts at 0x0001 and not 0x0000 as specified. Because of this the first PWM period has one more clock cycle.

##### Fix/Workaround

- The first period is 0x0000, 0x0001, ..., period
- Consecutive periods are 0x0001, 0x0002, ..., period

#### 3. PWM update period to a 0 value does not work

It is impossible to update a period equal to 0 by the using the PWM update register (PWM\_CUPD).

##### Fix/Workaround

Do not update the PWM\_CUPD register with a value equal to 0.

### 41.4.2 ADC

#### 1. Sleep Mode activation needs additional A to D conversion

If the ADC sleep mode is activated when the ADC is idle the ADC will not enter sleep mode before after the next AD conversion.

##### Fix/Workaround

Activate the sleep mode in the mode register and then perform an AD conversion.

### 41.4.3 SPI

#### 1. SPI Slave / PDCA transfer: no TX UNDERRUN flag

There is no TX UNDERRUN flag available, therefore in SPI slave mode, there is no way to be informed of a character lost in transmission.

##### Fix/Workaround

For PDCA transfer: none.

#### 2. SPI FDIV option does not work

Selecting clock signal using FDIV = 1 does not work as specified.

##### Fix/Workaround

Do not set FDIV = 1

#### 3. SPI disable does not work in SLAVE mode.

##### Fix/Workaround

Read the last received data, then perform a Software Reset.

**4. SPI Bad Serial Clock Generation on 2nd chip\_select when SCBR = 1, CPOL=1 and NCPHA=0**

When multiple CS are in use, if one of the baudrate equals to 1 and one of the others doesn't equal to 1, and CPOL=1 and CPHA=0, then an additional pulse will be generated on SCK.

**Fix/workaround**

When multiple CS are in use, if one of the baudrate equals 1, the other must also equal 1 if CPOL=1 and CPHA=0.

**5. SPI Glitch on RXREADY flag in slave mode when enabling the SPI or during the first transfer**

In slave mode, the SPI can generate a false RXREADY signal during enabling of the SPI or during the first transfer.

**Fix/Workaround**

1. Set slave mode, set required CPOL/CPHA.
2. Enable SPI.
3. Set the polarity CPOL of the line in the opposite value of the required one.
4. Set the polarity CPOL to the required one.
5. Read the RXHOLDING register.

Transfers can now begin and RXREADY will now behave as expected.

**6. SPI Disable does not work in Slave mode**

**Fix/workaround**

Read the last received data then perform a Software reset.

## 41.4.4 Power Manager

**1. Wrong reset causes when BOD is activated**

Setting the BOD enable fuse will cause the Reset Cause Register to list BOD reset as the reset source even though the part was reset by another source.

**Fix/Workaround**

Do not set the BOD enable fuse, but activate the BOD as soon as your program starts.

**2. If the BOD level is higher than VDDCORE, the part is constantly under reset**

If the BOD level is set to a value higher than VDDCORE and enabled by fuses, the part will be in constant reset.

**Fix/Workaround**

Apply an external voltage on VDDCORE that is higher than the BOD level and is lower than VDDCORE max and disable the BOD.

## 41.4.5 FLASHC

**1. On AT32UC3A0512 and AT32UC3A1512, corrupted read in flash after FLASHC WP, EP, EA, WUP, EUP commands may happen**

- After a FLASHC Write Page (WP) or Erase Page (EP) command applied to a page in a given half of the flash (first or last 256 kB of flash), reading (data read or code fetch) the other half of the flash may fail. This may lead to an exception or to other errors derived from this corrupted read access.

- After a FLASHC Erase All (EA) command, reading (data read or code fetch) the flash may fail. This may lead to an exception or to other errors derived from this corrupted read access.

- After a FLASHC Write User Page (WUP) or Erase User Page (EUP) command, reading

(data read or code fetch) the second half (last 256 kB) of the flash may fail. This may lead to an exception or to other errors derived from this corrupted read access.

**Fix/Workaround**

Flashc WP, EP, EA, WUP, EUP commands: these commands must be issued from RAM or through the EBI. After these commands, read twice one flash page initialized to 00h in each half part of the flash.

**41.4.6 PDCA**

- 1. Wrong PDCA behavior when using two PDCA channels with the same PID.**

**Workaround/fix**

The same PID should not be assigned to more than one channel.

**41.4.7 TWI**

- 1. The TWI RXRDY flag in SR register is not reset when a software reset is performed.**

**Fix/Workaround**

After a Software Reset, the register TWI RHR must be read.

**41.4.8 SDRAMC**

- 1. Code execution from external SDRAM does not work**

Code execution from SDRAM does not work.

**Fix/Workaround**

Do not run code from SDRAM.

**41.4.9 GPIO**

- 1. Some GPIO VIH (input high voltage) are 3.6V max instead of 5V tolerant**

Only 11 GPIOs remain 5V tolerant (VIHmax=5V):PB01, PB02, PB03, PB10, PB19, PB20, PB21, PB22, PB23, PB27, PB28.

**Workaround/fix**

None.

**41.4.10 USART**

- 1. ISO7816 info register US\_NER cannot be read**

The NER register always returns zero.

**Fix/Workaround**

None.

**41.4.11 Processor and Architecture**

- 1. LDM instruction with PC in the register list and without ++ increments Rp**

For LDM with PC in the register list: the instruction behaves as if the ++ field is always set, ie the pointer is always updated. This happens even if the ++ field is cleared. Specifically, the increment of the pointer is done in parallel with the testing of R12.

**Fix/Workaround**

None.

- 2. RETE instruction does not clear SREG[L] from interrupts.**

The RETE instruction clears SREG[L] as expected from exceptions.

**Fix/Workaround**

When using the STCOND instruction, clear SREG[L] in the stacked value of SR before returning from interrupts with RETE.

- 3. Exceptions when system stack is protected by MPU**

RETS behaves incorrectly when MPU is enabled and MPU is configured so that system stack is not readable in unprivileged mode.

**Fix/Workaround**

Workaround 1: Make system stack readable in unprivileged mode,

or

Workaround 2: Return from supervisor mode using rete instead of rets. This requires :

1. Changing the mode bits from 001b to 110b before issuing the instruction.

Updating the mode bits to the desired value must be done using a single mtsr instruction so it is done atomically. Even if this step is described in general as not safe in the UC technical reference guide, it is safe in this very specific case.

2. Execute the RETE instruction.

#### 41.4.12 FLASHC

1. **Reading from on-chip flash may fail after a flash fuse write operation (FLASHC LP, UP, WGPB, EGPB, SSB, PGPFB, EAGPF commands).**

After a flash fuse write operation (FLASHC LP, UP, WGPB, EGPB, SSB, PGPFB, EAGPF commands), the following flash read access may return corrupted data. This erratum does not affect write operations to regular flash memory.

**Fix/Workaround**

The flash fuse write operation (FLASHC LP, UP, WGPB, EGPB, SSB, PGPFB, EAGPF commands) must be issued from internal RAM. After the write operation, perform a dummy flash page write operation (FLASHC WP). Content and location of this page is not important and filling the write buffer with all one (FFh) will leave the current flash content unchanged. It is then safe to read and fetch code from the flash.

## 41.5 Rev. E

## 41.5.1 SPI

**1. SPI FDIV option does not work**

Selecting clock signal using  $FDIV = 1$  does not work as specified.

**Fix/Workaround**

Do not set  $FDIV = 1$ .

**2. SPI Slave / PDCA transfer: no TX UNDERRUN flag**

There is no TX UNDERRUN flag available, therefore in SPI slave mode, there is no way to be informed of a character lost in transmission.

**Fix/Workaround**

For PDCA transfer: none.

**3. SPI Bad serial clock generation on 2nd chip select when SCBR=1, CPOL=1 and CNCPHA=0**

When multiple CS are in use, if one of the baudrate equals to 1 and one of the others doesn't equal to 1, and  $CPOL=1$  and  $CPHA=0$ , then an additional pulse will be generated on SCK.

**Fix/Workaround**

When multiple CS are in use, if one of the baudrate equals to 1, the other must also equal 1 if  $CPOL=1$  and  $CPHA=0$ .

**4. SPI Glitch on RXREADY flag in slave mode when enabling the SPI or during the first transfer**

In slave mode, the SPI can generate a false RXREADY signal during enabling of the SPI or during the first transfer.

**Fix/Workaround**

1. Set slave mode, set required CPOL/CPHA.
  2. Enable SPI.
  3. Set the polarity CPOL of the line in the opposite value of the required one.
  4. Set the polarity CPOL to the required one.
  5. Read the RXHOLDING register.
- Transfers can now begin and RXREADY will now behave as expected.

**5. SPI CSNAAT bit 2 in register CSR0...CSR3 is not available.****Fix/Workaround**

Do not use this bit.

**6. SPI disable does not work in SLAVE mode.****Fix/Workaround**

Read the last received data, then perform a Software Reset.

**7. SPI Bad Serial Clock Generation on 2nd chip\_select when SCBR = 1, CPOL=1 and NCPHA=0**

When multiple CS are in use, if one of the baudrate equals to 1 and one of the others doesn't equal to 1, and  $CPOL=1$  and  $CPHA=0$ , then an additional pulse will be generated on SCK.



**Fix/workaround**

When multiple CS are in use, if one of the baudrate equals 1, the other must also equal 1 if CPOL=1 and CPHA=0.

**41.5.2 PWM****1. PWM counter restarts at 0x0001**

The PWM counter restarts at 0x0001 and not 0x0000 as specified. Because of this the first PWM period has one more clock cycle.

**Fix/Workaround**

- The first period is 0x0000, 0x0001, ..., period
- Consecutive periods are 0x0001, 0x0002, ..., period

**2. PWM channel interrupt enabling triggers an interrupt**

When enabling a PWM channel that is configured with center aligned period (CALG=1), an interrupt is signalled.

**Fix/Workaround**

When using center aligned mode, enable the channel and read the status before channel interrupt is enabled.

**3. PWM update period to a 0 value does not work**

It is impossible to update a period equal to 0 by the using the PWM update register (PWM\_CUPD).

**Fix/Workaround**

Do not update the PWM\_CUPD register with a value equal to 0.

**4. PWM channel status may be wrong if disabled before a period has elapsed**

Before a PWM period has elapsed, the read channel status may be wrong. The CHIDx-bit for a PWM channel in the PWM Enable Register will read '1' for one full PWM period even if the channel was disabled before the period elapsed. It will then read '0' as expected.

**Fix/Workaround**

Reading the PWM channel status of a disabled channel is only correct after a PWM period has elapsed.

**41.5.3 SSC****1. SSC does not trigger RF when data is low**

The SSC cannot transmit or receive data when CKS = CKDIV and CKO = none, in TCMR or RCMR respectively.

**Fix/Workaround**

Set CKO to a value that is not "none" and bypass the output of the TK/RK pin with the PIO.

**2. SSC Data is not sent unless clock is set as output**

The SSC cannot transmit or receive data when CKS = CKDIV and CKO = none, in TCMR or RCMR respectively.

**Fix/Workaround**

Set CKO to a value that is not "none" and bypass the output of the TK/RK pin with the PIO.





#### 41.5.4 USB

##### 1. USB No end of host reset signaled upon disconnection

In host mode, in case of an unexpected device disconnection whereas a usb reset is being sent by the usb controller, the UHCON.RESET bit may not be cleared by the hardware at the end of the reset.

###### Fix/Workaround

A software workaround consists in testing (by polling or interrupt) the disconnection (UHINT.DDISCI == 1) while waiting for the end of reset (UHCON.RESET == 0) to avoid being stuck.

##### 2. USBFSM and UHADDR1/2/3 registers are not available.

Do not use USBFSM register.

###### Fix/Workaround

Do not use USBFSM register and use HCON[6:0] field instead for all the pipes.

#### 41.5.5 Processor and Architecture

##### 1. Incorrect Processor ID

The processor ID reads 0x01 and not 0x02 as it should.

###### Fix/Workaround

None.

##### 2. Bus error should be masked in Debug mode

If a bus error occurs during debug mode, the processor will not respond to debug commands through the DINST register.

###### Fix/Workaround

A reset of the device will make the CPU respond to debug commands again.

##### 3. Read Modify Write (RMW) instructions on data outside the internal RAM does not work.

Read Modify Write (RMW) instructions on data outside the internal RAM does not work.

###### Fix/Workaround

Do not perform RMW instructions on data outside the internal RAM.

##### 4. CRC calculation of a locked device will calculate CRC for 512 kB of flash memory, even though the part has less flash.

###### Fix/Workaround

The flash address space is wrapping, so it is possible to use the CRC value by calculating CRC of the flash content concatenated with itself N times. Where N is 512 kB/flash size.

##### 5. Need two NOPs instruction after instructions masking interrupts

The instructions following in the pipeline the instruction masking the interrupt through SR may behave abnormally.

###### Fix/Workaround

Place two NOPs instructions after each SSRF or MTSR instruction setting IxM or GM in SR.

- 6. CPU Cycle Counter does not reset the COUNT system register on COMPARE match.**  
 The device revision E does not reset the COUNT system register on COMPARE match. In this revision, the COUNT register is clocked by the CPU clock, so when the CPU clock stops, so does incrementing of COUNT.

**Fix/Workaround**

None.

- 7. Memory Protection Unit (MPU) is non functional.**

**Fix/Workaround**

Do not use the MPU.

- 8. The following alternate GPIO function C are not available in revE**

MACB-WOL on GPIO9 (PA09), MACB-WOL on GPIO18 (PA18), USB-USB\_ID on GPIO21 (PA21), USB-USB\_VBOF on GPIO22 (PA22), and all function B and C on GPIO70 to GPIO101 (PX00 to PX39).

**Fix/Workaround**

Do not use these alternate B and C functions on the listed GPIO pins.

- 9. Clock connection table on Rev E**

Here is the table of Rev E

**Figure 41-1.** Timer/Counter clock connections on RevE

Source	Name	Connection
Internal	TIMER_CLOCK1	32 KHz Oscillator
	TIMER_CLOCK2	PBA Clock / 4
	TIMER_CLOCK3	PBA Clock / 8
	TIMER_CLOCK4	PBA Clock / 16
	TIMER_CLOCK5	PBA Clock / 32
External	XC0	
	XC1	
	XC2	

- 10. Local Bus fast GPIO not available in RevE.**

**Fix/Workaround**

Do not use on this silicon revision.

- 11. Spurious interrupt may corrupt core SR mode to exception**

If the rules listed in the chapter 'Masking interrupt requests in peripheral modules' of the AVR32UC Technical Reference Manual are not followed, a spurious interrupt may occur. An interrupt context will be pushed onto the stack while the core SR mode will indicate an exception. A RETE instruction would then corrupt the stack..

**Fix/Workaround**

Follow the rules of the AVR32UC Technical Reference Manual. To increase software robustness, if an exception mode is detected at the beginning of an interrupt handler, change the stack interrupt context to an exception context and issue a RETE instruction.

**12. CPU cannot operate on a divided slow clock (internal RC oscillator)****Fix/Workaround**

Do not run the CPU on a divided slow clock.

**13. LDM instruction with PC in the register list and without ++ increments Rp**

For LDM with PC in the register list: the instruction behaves as if the ++ field is always set, ie the pointer is always updated. This happens even if the ++ field is cleared. Specifically, the increment of the pointer is done in parallel with the testing of R12.

**Fix/Workaround**

None.

**14. RETE instruction does not clear SREG[L] from interrupts.**

The RETE instruction clears SREG[L] as expected from exceptions.

**Fix/Workaround**

When using the STCOND instruction, clear SREG[L] in the stacked value of SR before returning from interrupts with RETE.

**15. Exceptions when system stack is protected by MPU**

RETS behaves incorrectly when MPU is enabled and MPU is configured so that system stack is not readable in unprivileged mode.

**Fix/Woraround**

Workaround 1: Make system stack readable in unprivileged mode,  
or

Workaround 2: Return from supervisor mode using rete instead of rets. This requires :

1. Changing the mode bits from 001b to 110b before issuing the instruction. Updating the mode bits to the desired value must be done using a single mtsr instruction so it is done atomically. Even if this step is described in general as not safe in the UC technical reference guide, it is safe in this very specific case.

2. Execute the RETE instruction.

**41.5.6 SDRAMC****1. Code execution from external SDRAM does not work**

Code execution from SDRAM does not work.

**Fix/Workaround**

Do not run code from SDRAM.

**2. SDRAM SDCKE rise at the same time as SDCK while exiting self-refresh mode**

SDCKE rise at the same time as SDCK while exiting self-refresh mode.

**Fix/Workaround**

None.

**41.5.7 USART****1. USART Manchester Encoder Not Working**

Manchester encoding/decoding is not working.

**Fix/Workaround**

Do not use manchester encoding.

**2. USART RXBREAK problem when no timeguard**

In asynchronous mode the RXBREAK flag is not correctly handled when the timeguard is 0 and the break character is located just after the stop bit.

**Fix/Workaround**

If the NBSTOP is 1, timeguard should be different from 0.

**3. USART Handshaking: 2 characters sent / CTS rises when TX**

If CTS switches from 0 to 1 during the TX of a character, if the Holding register is not empty, the TXHOLDING is also transmitted.

**Fix/Workaround**

None.

**4. USART PDC and TIMEGUARD not supported in MANCHESTER**

Manchester encoding/decoding is not working.

**Fix/Workaround**

Do not use manchester encoding.

**5. USART SPI mode is non functional on this revision.****Fix/Workaround**

Do not use the USART SPI mode.

**6. DCD is active High instead of Low.**

In modem mode the DCD signal is assumed to be active high by the USART, but should have been active low.

**Fix/Workaround**

Add an external inverter to the DCD line.

**7. ISO7816 info register US\_NER cannot be read**

The NER register always returns zero.

**Fix/Workaround**

None.

**41.5.8 Power Manager****1. Voltage regulator input and output is connected to VDDIO and VDDCORE inside the device**

The voltage regulator input and output is connected to VDDIO and VDDCORE respectively inside the device.

**Fix/Workaround**

Do not supply VDDCORE externally, as this supply will work in parallel with the regulator.

**2. Wrong reset causes when BOD is activated**

Setting the BOD enable fuse will cause the Reset Cause Register to list BOD reset as the reset source even though the part was reset by another source.

**Fix/Workaround**

Do not set the BOD enable fuse, but activate the BOD as soon as your program starts.

**3. PLL0/1 Lock control does not work**

Lock Control does not work for PLL0 and PLL1.

## Fix/Workaround

In PLL0/1 Control register, the bit 7 should be set in order to prevent unexpected behaviour.

### 4. Peripheral Bus A maximum frequency is 33MHz instead of 66MHz.

#### Fix/Workaround

Do not set PBA frequency higher than 33 MHz.

### 5. PCx pins go low in stop mode

In sleep mode stop all PCx pins will be controlled by GPIO module instead of oscillators. This can cause drive contention on the XINx in worst case.

#### Fix/Workaround

Before entering stop mode set all PCx pins to input and GPIO controlled.

### 6. On some rare parts, the maximum HSB and CPU speed is 50MHz instead of 66MHz.

#### Fix/Workaround

Do not set the HSB/CPU speed higher than 50MHz when the firmware generate exceptions.

### 7. If the BOD level is higher than VDDCORE, the part is constantly under reset

If the BOD level is set to a value higher than VDDCORE and enabled by fuses, the part will be in constant reset.

#### Fix/Workaround

Apply an external voltage on VDDCORE that is higher than the BOD level and is lower than VDDCORE max and disable the BOD.

### 8. System Timer mask (Bit 16) of the PM CPUMASK register is not available.

#### Fix/Workaround

Do not use this bit.

## 41.5.9 HMatrix

### 1. HMatrix fixed priority arbitration does not work

Fixed priority arbitration does not work.

#### Fix/Workaround

Use Round-Robin arbitration instead.

## 41.5.10 ADC

### 1. ADC possible miss on DRDY when disabling a channel

The ADC does not work properly when more than one channel is enabled.

#### Fix/Workaround

Do not use the ADC with more than one channel enabled at a time.

### 2. ADC OVRE flag sometimes not reset on Status Register read

The OVRE flag does not clear properly if read simultaneously to an end of conversion.

#### Fix/Workaround

None.

### 3. Sleep Mode activation needs additional A to D conversion

If the ADC sleep mode is activated when the ADC is idle the ADC will not enter sleep mode before after the next AD conversion.

**Fix/Workaround**

Activate the sleep mode in the mode register and then perform an AD conversion.

## 41.5.11 ABDAC

1. **Audio Bitstream DAC is not functional.**

**Fix/Workaround**

Do not use the ABDAC on revE.

## 41.5.12 FLASHC

1. **The address of Flash General Purpose Fuse Register Low (FGPFRLO) is 0xFFFE140C on revE instead of 0xFFFE1410.**

**Fix/Workaround**

None.

2. **The command Quick Page Read User Page(QPRUP) is not functional.**

**Fix/Workaround**

None.

3. **PAGEN Semantic Field for Program GP Fuse Byte is WriteData[7:0], ByteAddress[1:0] on revision E instead of WriteData[7:0], ByteAddress[2:0].**

**Fix/Workaround**

None.

4. **On AT32UC3A0512 and AT32UC3A1512, corrupted read in flash after FLASHC WP, EP, EA, WUP, EUP commands may happen**

- After a FLASHC Write Page (WP) or Erase Page (EP) command applied to a page in a given half of the flash (first or last 256 kB of flash), reading (data read or code fetch) the other half of the flash may fail. This may lead to an exception or to other errors derived from this corrupted read access.

- After a FLASHC Erase All (EA) command, reading (data read or code fetch) the flash may fail. This may lead to an exception or to other errors derived from this corrupted read access.

- After a FLASHC Write User Page (WUP) or Erase User Page (EUP) command, reading (data read or code fetch) the second half (last 256 kB) of the flash may fail. This may lead to an exception or to other errors derived from this corrupted read access.

**Fix/Workaround**

Flashc WP, EP, EA, WUP, EUP commands: these commands must be issued from RAM or through the EBI. After these commands, read twice one flash page initialized to 00h in each half part of the flash.

## 41.5.13 RTC

1. **Writes to control (CTRL), top (TOP) and value (VAL) in the RTC are discarded if the RTC peripheral bus clock (PBA) is divided by a factor of four or more relative to the HSB clock.**

**Fix/Workaround**

Do not write to the RTC registers using the peripheral bus clock (PBA) divided by a factor of four or more relative to the HSB clock.

2. **The RTC CLKEN bit (bit number 16) of CTRL register is not available.**

**Fix/Workaround**

Do not use the CLKEN bit of the RTC on Rev E.

#### 41.5.14 OCD

1. **Stalled memory access instruction writeback fails if followed by a HW breakpoint.**

Consider the following assembly code sequence:

A

B

If a hardware breakpoint is placed on instruction B, and instruction A is a memory access instruction, register file updates from instruction A can be discarded.

**Fix/Workaround**

Do not place hardware breakpoints, use software breakpoints instead.

Alternatively, place a hardware breakpoint on the instruction before the memory access instruction and then single step over the memory access instruction.

#### 41.5.15 PDCA

1. **Wrong PDCA behavior when using two PDCA channels with the same PID.**

**Workaround/fix**

The same PID should not be assigned to more than one channel.

#### 41.5.16 TWI

1. **The TWI RXRDY flag in SR register is not reset when a software reset is performed.**

**Fix/Workaround**

After a Software Reset, the register TWI RHR must be read.

#### 41.5.17 FLASHC

1. **Reading from on-chip flash may fail after a flash fuse write operation (FLASHC LP, UP, WGPB, EGPB, SSB, PGPFB, EAGPF commands).**

After a flash fuse write operation (FLASHC LP, UP, WGPB, EGPB, SSB, PGPFB, EAGPF commands), the following flash read access may return corrupted data. This erratum does not affect write operations to regular flash memory.

**Fix/Workaround**

The flash fuse write operation (FLASHC LP, UP, WGPB, EGPB, SSB, PGPFB, EAGPF commands) must be issued from internal RAM. After the write operation, perform a dummy flash page write operation (FLASHC WP). Content and location of this page is not important and filling the write buffer with all one (FFh) will leave the current flash content unchanged. It is then safe to read and fetch code from the flash.

## 42. Datasheet Revision History

Please note that the referring page numbers in this section are referred to this document. The referring revision in this section are referring to the document revision.

### 42.1 Rev. K – 01/12

1. Update Errata Section
2. Update Electrical characteristic Section

### 42.2 Rev. I – 11/09

1. Remove ordering code for automotive engineering samples
2. Replace old automotive ordering codes AT32UC3A0512-ALTR (revision I) by AT32UC3A0512-ALTRA (revision K).  
Replace old automotive ordering codes AT32UC3A0512-ALTT (revision I) by AT32UC3A0512-ALTTA (revision K).

### 42.3 Rev. H – 03/09

1. Update ["Errata" on page 779](#).
2. Update electrical characteristic in ["DC Characteristics" on page 2](#).
3. Add BGA144 package information.

### 42.4 Rev. G – 01/09

1. Update ["Errata" on page 779](#).
2. Update GPIO electrical characteristic in ["DC Characteristics" on page 2](#).

### 42.5 Rev. F – 08/08

1. Add revision J to ["Errata" on page 779](#).
2. Update DMIPS number in ["Features" on page 1](#).



**42.6 Rev. E – 04/08**

1. Open Drain Mode removed from "General-Purpose Input/Output Controller (GPIO)" on page 151.

**42.7 Rev. D – 04/08**

1. Updated "Signal Description List" on page 8. Removed RXDN and TXDN from USART section.
2. Updated "Errata" on page 779. Rev G replaced by rev H.

**42.8 Rev. C – 10/07**

1. Updated "Signal Description List" on page 8. Removed RXDN and TXDN from USART section.
2. Updated "Errata" on page 779. Rev G replaced by rev H.

**42.9 Rev. B – 10/07**

1. Updated "Features" on page 1.
2. Update "Blockdiagram" on page 4 with local bus.
3. Updated "Peripherals" on page 34 with local bus.
4. Add SPI feature in "Universal Synchronous/Asynchronous Receiver/Transmitter (USART)" on page 315.
5. Updated "USB On-The-Go Interface (USBB)" on page 517.
6. Updated "JTAG and Boundary Scan" on page 750 with programming procedure .
7. Add description for silicon Rev G.

**42.10 Rev. A – 03/07**

1. Initial revision.

## Table of Contents

<b>1</b>	<b>Description</b> .....	<b>3</b>
<b>2</b>	<b>Configuration Summary</b> .....	<b>4</b>
<b>3</b>	<b>Abbreviations</b> .....	<b>4</b>
<b>4</b>	<b>Blockdiagram</b> .....	<b>5</b>
	4.1 Processor and architecture .....	6
<b>5</b>	<b>Signals Description</b> .....	<b>8</b>
<b>6</b>	<b>Power Considerations</b> .....	<b>13</b>
	6.1 Power Supplies .....	13
	6.2 Voltage Regulator .....	14
	6.3 Analog-to-Digital Converter (A.D.C) reference. ....	15
<b>7</b>	<b>Package and Pinout</b> .....	<b>16</b>
<b>8</b>	<b>I/O Line Considerations</b> .....	<b>20</b>
	8.1 JTAG pins .....	20
	8.2 RESET_N pin .....	20
	8.3 TWI pins .....	20
	8.4 GPIO pins .....	20
<b>9</b>	<b>Processor and Architecture</b> .....	<b>21</b>
	9.1 AVR32 Architecture .....	21
	9.2 The AVR32UC CPU .....	21
	9.3 Programming Model .....	25
	9.4 Exceptions and Interrupts .....	29
<b>10</b>	<b>Memories</b> .....	<b>33</b>
	10.1 Embedded Memories .....	33
	10.2 Physical Memory Map .....	33
	10.3 Bus Matrix Connections .....	34
<b>11</b>	<b>Fuses Settings</b> .....	<b>36</b>
	11.1 Flash General Purpose Fuse Register (FGPFRLO) .....	36
	11.2 Default Fuse Value .....	37
<b>12</b>	<b>Peripherals</b> .....	<b>38</b>
	12.1 Peripheral address map .....	38
	12.2 CPU Local Bus Mapping .....	39

12.3	Interrupt Request Signal Map . . . . .	41
12.4	Clock Connections . . . . .	43
12.5	Nexus OCD AUX port connections . . . . .	44
12.6	PDC handshake signals . . . . .	44
12.7	Peripheral Multiplexing on I/O lines . . . . .	45
12.8	Oscillator Pinout . . . . .	48
12.9	USART Configuration . . . . .	48
12.10	GPIO . . . . .	49
12.11	Peripheral overview . . . . .	49
<b>13</b>	<b>Power Manager (PM) . . . . .</b>	<b>53</b>
13.1	Features . . . . .	53
13.2	Description . . . . .	53
13.3	Block Diagram . . . . .	54
13.4	Product Dependencies . . . . .	55
13.5	Functional Description . . . . .	55
13.6	User Interface . . . . .	66
<b>14</b>	<b>Real Time Counter (RTC) . . . . .</b>	<b>86</b>
14.1	Features . . . . .	86
14.2	Description . . . . .	86
14.3	Block Diagram . . . . .	87
14.4	Product Dependencies . . . . .	87
14.5	Functional Description . . . . .	87
14.6	User Interface . . . . .	89
<b>15</b>	<b>Watchdog Timer (WDT) . . . . .</b>	<b>94</b>
15.1	Features . . . . .	94
15.2	Description . . . . .	94
15.3	Block Diagram . . . . .	94
15.4	Product Dependencies . . . . .	94
15.5	Functional Description . . . . .	95
15.6	User Interface . . . . .	96
<b>16</b>	<b>Interrupt Controller (INTC) . . . . .</b>	<b>99</b>
16.1	Description . . . . .	99
16.2	Block Diagram . . . . .	99
16.3	Operation . . . . .	99
16.4	User Interface . . . . .	101

<b>17</b>	<b><i>External Interrupts Controller (EIC)</i></b>	<b>105</b>
17.1	Features	105
17.2	Description	105
17.3	Block Diagram	106
17.4	Product Dependencies	106
17.5	Functional Description	107
17.6	User Interface	109
<b>18</b>	<b><i>Flash Controller (FLASHC)</i></b>	<b>115</b>
18.1	Features	115
18.2	Description	115
18.3	Product dependencies	115
18.4	Functional description	116
18.5	Flash commands	118
18.6	General-purpose fuse bits	120
18.7	Security bit	122
18.8	User interface	123
<b>19</b>	<b><i>HSB Bus Matrix (HMATRIX)</i></b>	<b>132</b>
19.1	Features	132
19.2	Description	132
19.3	Memory Mapping	132
19.4	Special Bus Granting Mechanism	132
19.5	Arbitration	133
19.6	Slave and Master assignation	135
19.7	User Interface	136
<b>20</b>	<b><i>External Bus Interface (EBI)</i></b>	<b>145</b>
20.1	Features	145
20.2	Description	145
20.3	Block Diagram	146
20.4	I/O Lines Description	147
20.5	Application Example	148
20.6	Product Dependencies	151
20.7	Functional Description	151
<b>21</b>	<b><i>Peripheral DMA Controller (PDCA)</i></b>	<b>153</b>
21.1	Features	153
21.2	Overview	153

12.3	Interrupt Request Signal Map .....	41
12.4	Clock Connections .....	43
12.5	Nexus OCD AUX port connections .....	44
12.6	PDC handshake signals .....	44
12.7	Peripheral Multiplexing on I/O lines .....	45
12.8	Oscillator Pinout .....	48
12.9	USART Configuration .....	48
12.10	GPIO .....	49
12.11	Peripheral overview .....	49
<b>13</b>	<b>Power Manager (PM) .....</b>	<b>53</b>
13.1	Features .....	53
13.2	Description .....	53
13.3	Block Diagram .....	54
13.4	Product Dependencies .....	55
13.5	Functional Description .....	55
13.6	User Interface .....	66
<b>14</b>	<b>Real Time Counter (RTC) .....</b>	<b>86</b>
14.1	Features .....	86
14.2	Description .....	86
14.3	Block Diagram .....	87
14.4	Product Dependencies .....	87
14.5	Functional Description .....	87
14.6	User Interface .....	89
<b>15</b>	<b>Watchdog Timer (WDT) .....</b>	<b>94</b>
15.1	Features .....	94
15.2	Description .....	94
15.3	Block Diagram .....	94
15.4	Product Dependencies .....	94
15.5	Functional Description .....	95
15.6	User Interface .....	96
<b>16</b>	<b>Interrupt Controller (INTC) .....</b>	<b>99</b>
16.1	Description .....	99
16.2	Block Diagram .....	99
16.3	Operation .....	99
16.4	User Interface .....	101

25.1	<b>Features</b>	<b>259</b>
25.2	Overview	259
25.3	Block Diagram	260
25.4	Application Block Diagram	260
25.5	I/O Lines Description	261
25.6	Product Dependencies	261
25.7	Functional Description	261
25.8	SSC Application Examples	273
25.9	User Interface	275
<b>26</b>	<b>Universal Synchronous/Asynchronous Receiver/Transmitter (USART)</b>	<b>299</b>
26.1	Features	299
26.2	Overview	299
26.3	Block Diagram	300
26.4	Application Block Diagram	301
26.5	I/O Lines Description	302
26.6	Product Dependencies	303
26.7	Functional Description	304
26.8	Universal Synchronous/Asynchronous Receiver/Transmitter (USART) User Interface	339
<b>27</b>	<b>Static Memory Controller (SMC)</b>	<b>366</b>
27.1	Features	366
27.2	Overview	366
27.3	Block Diagram	367
27.4	I/O Lines Description	367
27.5	Product Dependencies	368
27.6	Functional Description	368
27.7	User Interface	403
<b>28</b>	<b>SDRAM Controller (SDRAMC)</b>	<b>410</b>
28.1	Features	410
28.2	Description	410
28.3	Block Diagram	411
28.4	I/O Lines Description	411
28.5	Application Example	412
28.6	Product Dependencies	415
28.7	Functional Description	417
28.8	SDRAM Controller User Interface	424

<b>29</b>	<b><i>Ethernet MAC (MACB)</i></b>	<b>437</b>
29.1	Features	437
29.2	Description	437
29.3	Block Diagram	438
29.4	Product Dependencies	438
29.5	Functional Description	439
29.6	Programming Interface	451
29.7	Ethernet MAC (MACB) User Interface	454
<b>30</b>	<b><i>USB On-The-Go Interface (USBB)</i></b>	<b>497</b>
30.1	Features	497
30.2	Description	497
30.3	Block Diagram	499
30.4	Application Block Diagram	500
30.5	I/O Lines Description	501
30.6	Product Dependencies	502
30.7	Functional Description	503
30.8	USB User Interface	530
<b>31</b>	<b><i>Timer/Counter (TC)</i></b>	<b>639</b>
31.1	Features	639
31.2	Description	639
31.3	Block Diagram	640
31.4	Pin Name List	641
31.5	Product Dependencies	641
31.6	Functional Description	641
31.7	Timer Counter (TC) User Interface	654
<b>32</b>	<b><i>Pulse Width Modulation Controller (PWM)</i></b>	<b>673</b>
32.1	Features	673
32.2	Description	673
32.3	Block Diagram	674
32.4	I/O Lines Description	674
32.5	Product Dependencies	675
32.6	Functional Description	676
32.7	Pulse Width Modulation (PWM) Controller User Interface	684
<b>33</b>	<b><i>Analog-to-Digital Converter (ADC)</i></b>	<b>699</b>
33.1	Features	699

33.2	Overview . . . . .	699
33.3	Block Diagram . . . . .	700
33.4	I/O Lines Description . . . . .	700
33.5	Product Dependencies . . . . .	700
33.6	Functional Description . . . . .	702
33.7	User Interface . . . . .	707
<b>34</b>	<b>Audio Bitstream DAC (ABDAC) . . . . .</b>	<b>721</b>
34.1	Features . . . . .	721
34.2	Description . . . . .	721
34.3	Block Diagram . . . . .	722
34.4	Pin Name List . . . . .	722
34.5	Product Dependencies . . . . .	722
34.6	Functional Description . . . . .	723
34.7	Audio Bitstream DAC User Interface . . . . .	725
34.8	Frequency Response . . . . .	733
<b>35</b>	<b>On-Chip Debug . . . . .</b>	<b>734</b>
35.1	Features . . . . .	734
35.2	Overview . . . . .	734
35.3	Block diagram . . . . .	735
35.4	Functional description . . . . .	735
<b>36</b>	<b>JTAG and Boundary Scan . . . . .</b>	<b>741</b>
36.1	Features . . . . .	741
36.2	Overview . . . . .	741
36.3	Block diagram . . . . .	742
36.4	I/O Lines Description . . . . .	743
36.5	Product Dependencies . . . . .	743
36.6	Functional description . . . . .	743
36.7	JTAG Instruction Summary . . . . .	748
36.8	Public JTAG instructions . . . . .	749
36.9	Private JTAG Instructions . . . . .	750
36.10	JTAG Data Registers . . . . .	760
36.11	SAB address map . . . . .	761
<b>37</b>	<b>Boot Sequence . . . . .</b>	<b>762</b>
37.1	Starting of clocks . . . . .	762
37.2	Fetching of initial instructions . . . . .	762



<b>38</b>	<b><i>Electrical Characteristics</i></b>	<b>763</b>
38.1	Absolute Maximum Ratings*	763
38.2	DC Characteristics	764
38.3	Regulator characteristics	765
38.4	Analog characteristics	765
38.5	Power Consumption	767
38.6	Clock Characteristics	769
38.7	Crystal Oscillator Characteristis	770
38.8	ADC Characteristics	772
38.9	EBI Timings	774
38.10	JTAG Timings	780
38.11	SPI Characteristics	781
38.12	MACB Characteristics	783
38.13	Flash Characteristics	785
<b>39</b>	<b><i>Mechanical Characteristics</i></b>	<b>787</b>
39.1	Thermal Considerations	787
39.2	Package Drawings	788
39.3	Soldering Profile	791
<b>40</b>	<b><i>Ordering Information</i></b>	<b>792</b>
40.1	Automotive Quality Grade	792
<b>41</b>	<b><i>Errata</i></b>	<b>793</b>
41.1	Rev. K	793
41.2	Rev. J	796
41.3	Rev. I	799
41.4	Rev. H	803
41.5	Rev. E	807
<b>42</b>	<b><i>Datasheet Revision History</i></b>	<b>816</b>
42.1	Rev. K – 01/12	816
42.2	Rev. G – 01/09	816
42.3	Rev. F – 08/08	816
42.4	Rev. E – 04/08	816
42.5	Rev. D – 04/08	816
42.6	Rev. C – 10/07	817
42.7	Rev. B – 10/07	817
42.8	Rev. A – 03/07	817

**Atmel Corporation**

2325 Orchard Parkway  
San Jose, CA 95131  
USA

**Tel:** (+1)(408) 441-0311

**Fax:** (+1)(408) 487-2600

[www.atmel.com](http://www.atmel.com)

**Atmel Asia Limited**

Unit 1-5 & 16, 19/F  
BEA Tower, Millennium City 5  
418 Kwun Tong Road  
Kwun Tong, Kowloon  
HONG KONG

**Tel:** (+852) 2245-6100

**Fax:** (+852) 2722-1369

**Atmel Munich GmbH**

Business Campus  
Parkring 4  
D-85748 Garching b. Munich  
GERMANY

**Tel:** (+49) 89-31970-0

**Fax:** (+49) 89-3194621

**Atmel Japan**

16F, Shin Osaki Kangyo Bldg.  
1-6-4 Osaka Shinagawa-ku  
Tokyo 104-0032  
JAPAN

**Tel:** (+81) 3-6417-0300

**Fax:** (+81) 3-6417-0370

© 2012 Atmel Corporation. All rights reserved.

Atmel®, Atmel logo and combinations thereof, AVR® and others are registered trademarks or trademarks of Atmel Corporation or its subsidiaries. Other terms and product names may be trademarks of others.

**Disclaimer:** The information in this document is provided in connection with Atmel products. No license, express or implied, by estoppel or otherwise, to any intellectual property right is granted by this document or in connection with the sale of Atmel products. **EXCEPT AS SET FORTH IN THE ATMEL TERMS AND CONDITIONS OF SALES LOCATED ON THE ATMEL WEBSITE, ATMEL ASSUMES NO LIABILITY WHATSOEVER AND DISCLAIMS ANY EXPRESS, IMPLIED OR STATUTORY WARRANTY RELATING TO ITS PRODUCTS INCLUDING, BUT NOT LIMITED TO, THE IMPLIED WARRANTY OF MERCHANTABILITY, FITNESS FOR A PARTICULAR PURPOSE, OR NON-INFRINGEMENT. IN NO EVENT SHALL ATMEL BE LIABLE FOR ANY DIRECT, INDIRECT, CONSEQUENTIAL, PUNITIVE, SPECIAL OR INCIDENTAL DAMAGES (INCLUDING, WITHOUT LIMITATION, DAMAGES FOR LOSS AND PROFITS, BUSINESS INTERRUPTION, OR LOSS OF INFORMATION) ARISING OUT OF THE USE OR INABILITY TO USE THIS DOCUMENT, EVEN IF ATMEL HAS BEEN ADVISED OF THE POSSIBILITY OF SUCH DAMAGES.** Atmel makes no representations or warranties with respect to the accuracy or completeness of the contents of this document and reserves the right to make changes to specifications and product descriptions at any time without notice. Atmel does not make any commitment to update the information contained herein. Unless specifically provided otherwise, Atmel products are not suitable for, and shall not be used in, automotive applications. Atmel products are not intended, authorized, or warranted for use as components in applications intended to support or sustain life.