



Features

- Identification Transponder in Plastic Brick Package
- Includes Ferrite Coil and Capacitor for Tuned Circuit Antenna
- Basic Component: Atmel® ATA5577M1330C IDIC®
- Contactless Power Supply
- Contactless Downlink Data Transmission
- Radio Frequency $f_{RF} = 125\text{kHz}$
- 363-bit EEPROM Memory in Total: 11 Blocks \times (32 Bits + 1 Lock-Bit)
 - 7 \times 32 Bits EEPROM User Memory Including 32-bit Password Memory
 - 2 \times 32 Bits Unique ID
 - 1 \times 32-bit Option Register in EEPROM to Set Up the Analog Front End:
 - Clock Detection Level
 - Gap Detection Level
 - Improved Downlink Timing
 - Clamp Voltage
 - Modulation Voltage
 - Soft Modulation Switching
 - Write Damping like the Atmel T5557/ATA5567 or with Resistor
 - Downlink Protocol
 - 1 \times 32-bit Configuration Register in EEPROM to Set Up:
 - Data Rate:
 - RF/2 to RF/128, Binary Selectable or
 - Fixed Basic Mode Rates
 - Modulation/Coding:
 - ASK, FSK, PSK, Manchester, Bi-phase, NRZ
 - Other Options:
 - Password Mode
 - Max Block Feature
 - Direct Access Mode
 - Sequence Terminator(s)
 - Block-wise Write Protection (Lock Bit)
 - Answer-On-Request (AOR) Mode
 - Inverse Data Output
 - Disable Test Mode Access
 - Fast Downlink (~6Kbits/s vs. ~3Kbits/s)
 - OTP Functionality
 - Init Delay (~67ms)

1. Description

The Atmel® ATA5577M1330C-PP is a contactless read/write identification transponder (IDIC®) for applications in the 125kHz frequency band. It consists of a plastic brick which accommodates the read/write IDIC ATA5577M1330C. The antenna comprises an LC circuit which serves as power supply and bi-directional communication interface.

The on-chip 363-bit EEPROM (11 blocks with 33 bits each) can be read and written block-wise from a base station (reader). Two dedicated blocks are reserved for setting the IDIC operating modes. Another block may be used for a password to prevent unauthorized writing.

Data is transmitted from the IDIC (uplink) using load modulation. This is achieved by damping the RF field with a resistive load. The IC receives and decodes serial base station commands (downlink) which are encoded as 100% amplitude-modulated (OOK) pulse-interval-encoded bit streams.

Figure 1-1. RFID System Using Atmel ATA5577M1-PP Transponder

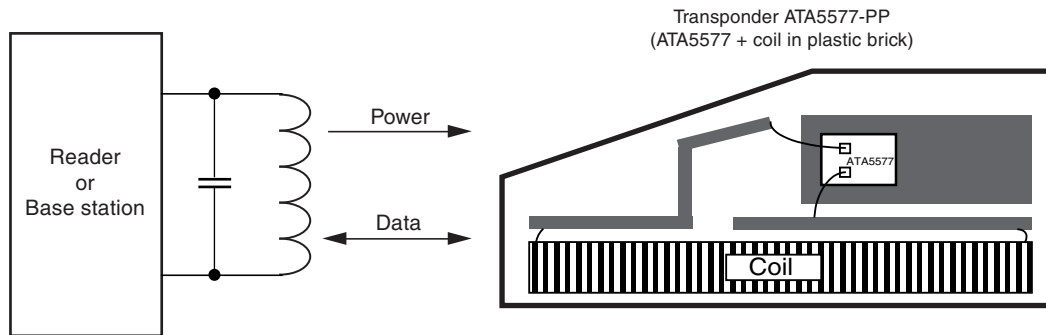

2. General

The transponder consists of a plastic brick which accommodates the following components:

- Atmel® ATA5577M1330C Read/Write IDIC®
- Coil with Ferrite Core

Note: The antenna is implemented as a tuned LC circuit

2.1 Transponder Antenna

The antenna consists of a coil and an on-chip capacitor of Atmel ATA5577M1330C for tuning the circuit to the nominal carrier frequency of 125kHz. The coil has a ferrite core for improving the distance of read, write and programming operations.

2.2 Atmel ATA5577M1-PP Transponder Operation

The Atmel read/write IDIC ATA5577M1330C is part of the Atmel transponder ATA5577M1330C-PP. The data is transmitted bi-directionally between the base station and the transponder. The transponder receives power via a single coil from the RF signal generated by the base station. The single coil is connected to the chip and also serves as the IC's bi-directional communication interface.

Data is transmitted by modulating the amplitude of the RF signal. The register contents are read by damping the coil voltage using an internal load. Writing into registers occurs by interrupting the RF field in a specific way. The Atmel ATA5577M1330C-PP transponder operates at a nominal frequency of 125kHz. There are varying bit rates and encoding schemes. The on-chip 363-bit EEPROM (11 blocks with 33 bits each) can be read and written block-wise from a base station (reader). The blocks can be protected against overwriting by using lock bits. Two blocks contain Atmel's production information and form a unique ID numbering system. Another block may contain a password to prevent unauthorized writing. Two blocks are reserved for setting the IC's operating modes. See the Atmel ATA5577C datasheet for more detailed information about Atmel ATA5577M1330C operating modes.

3. Absolute Maximum Ratings

Stresses beyond those listed under “Absolute Maximum Ratings” may cause permanent damage to the device. This is a stress rating only and functional operation of the device at these or any other conditions beyond those indicated in the operational sections of this specification is not implied. Exposure to absolute maximum rating conditions for extended periods may affect device reliability.

Parameters	Symbol	Value	Unit
Operating temperature range	Tamb	-40 to +85	°C
Storage temperature range (data retention reduced)	Tamb	-40 to +125	°C
Maximum assembly temperature, t < 5min	Tass	170	°C
Magnetic field strength at f = 125kHz	Hpp	1000	A/m

4. Electrical Characteristics

No.	Parameters	Test Conditions	Symbol	Min.	Typ.	Max.	Unit	Type*
1	Inductance		L	4.8	4.9	5.0	mH	Q
2.1	LC Circuit	Hpp = 14.5A/m	fr	120	125	130	kHz	T
2.2		Hpp = 1.5A/m	QLC	15	20	35	1	T
3	Max. field strength where tag does not modulate	Quiet mode	Hpp not	-	2	-	A/m	Q
4	Min. field for modulation	Read mode	Hpp mod	-	14.5	-	A/m	T
5	Min. field for programming	Write mode	Hpp prog	-	29	-	A/m	T
6	Maximum field strength		Hpp max			600	A/m	Q

*) Type means: T: directly or indirectly tested during production; Q: guaranteed based on initial product qualification data

5. Measurement Assembly

All parameters are measured in a Helmholtz arrangement, which generates a homogenous magnetic field (see [Figure 5-1](#) and [Figure 5-2](#)). A function generator drives the field generating coils, so magnetic field frequency and strength can be varied.

Figure 5-1. Testing Application

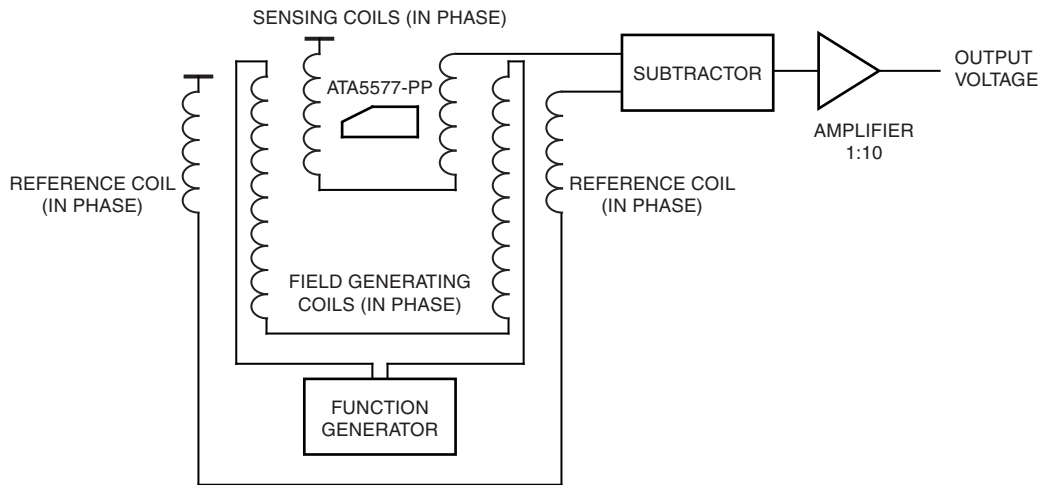
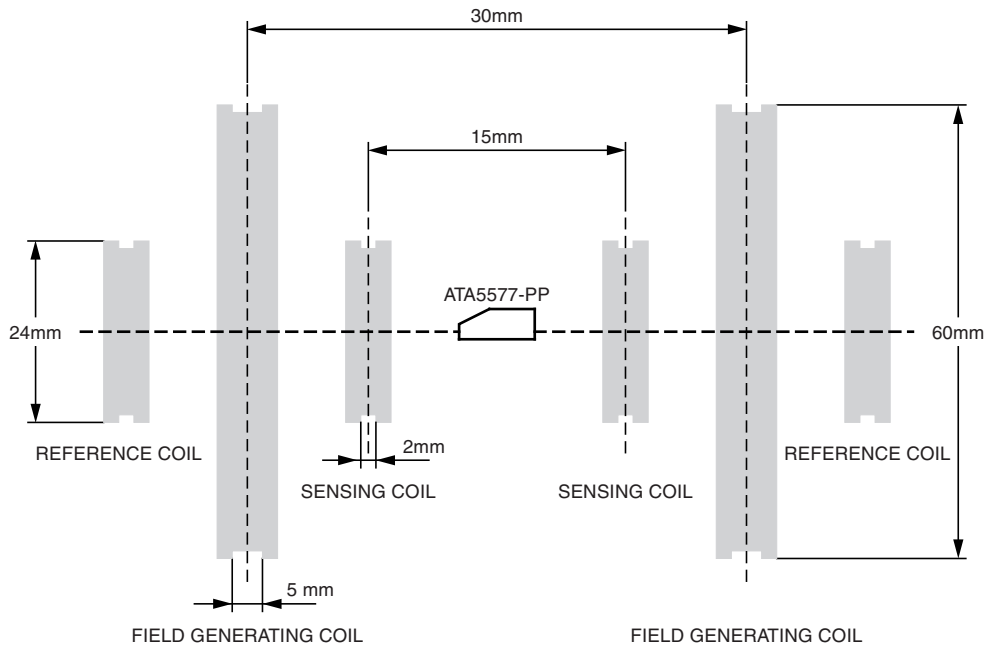

Figure 5-2. Testing Geometry



6. Ordering Information

6.1 Available Order Codes

ATA5577M1330C-PP

6.2 Configuration on Delivery

After Atmel® completes production, the transponder is configured as shown in [Table 6-1](#). Unlike the ATA5577M1330C chip, the AFE option setup (block 3, page 1) is adjusted to the transponder operating mode suitable for most applications.

All blocks in page 0 are not locked and may be re-programmed by the customer. Block 0 in page 0 is the configuration register and is pre-programmed to the Atmel default operating mode: Manchester modulation with a data rate of RF/32. 2 data blocks (block 1 and block 2 in page 0) are transferred. The data of this 2 blocks is set to 0.

Table 6-1. Configuration on Delivery State

Block	Address	Value	Comment
AFE option setup	block 3, page 1	0x 6DC0 0000	Soft modulation 2 pulses, clamp high, modulation low
Configregister	block 0, page 0	0x 0008 8040	RF/32, Manchester, Maxblock = 2
User data block 1	block 1, page 0	0x 0000 0000	All '0'
User data block 2	block 2, page 0	0x 0000 0000	All '0'

7. Package Information

Package: Transponder
Dimensions in mm

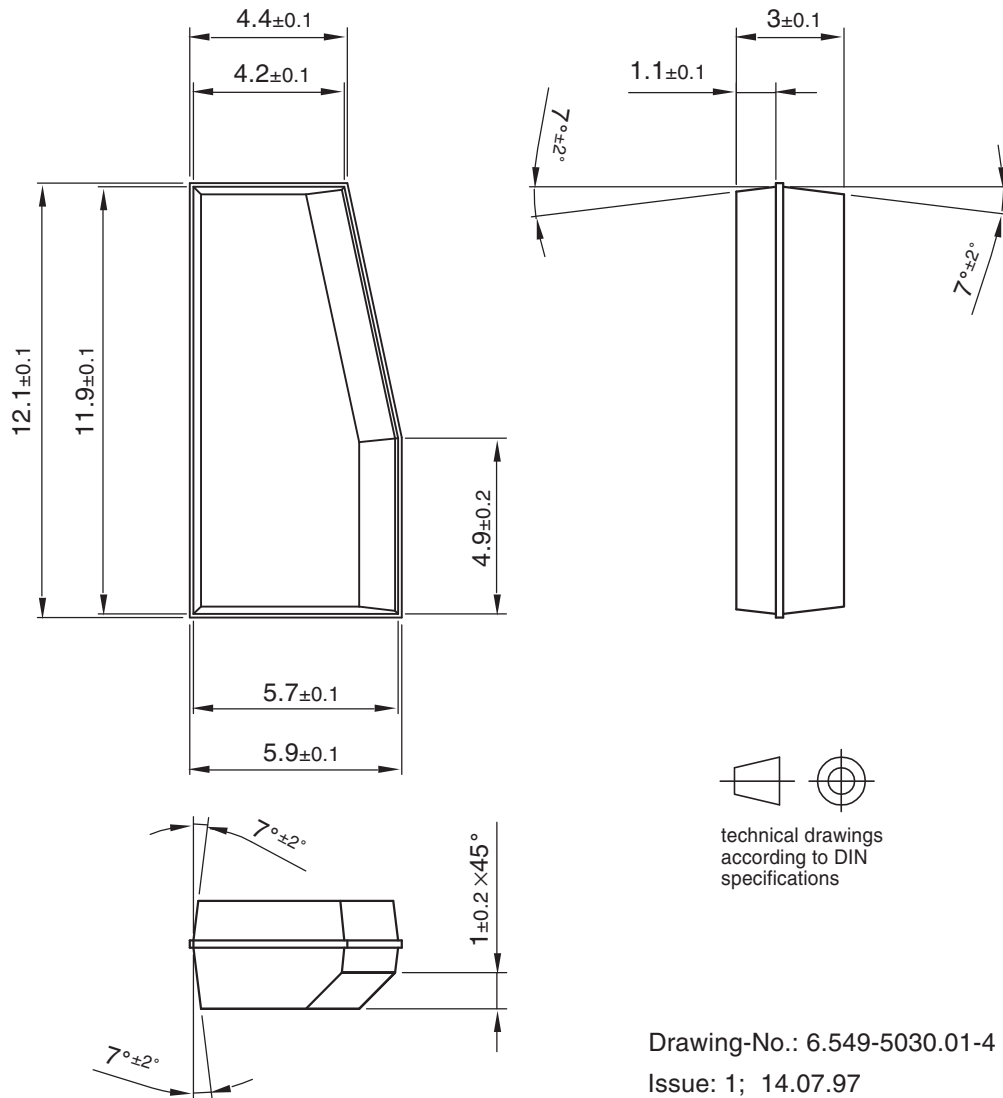

8. Revision History

Please note that the following page numbers referred to in this section refer to the specific revision mentioned, not to this document.

Revision No.	History
9225B-RFID-04/12	<ul style="list-style-type: none"> Set datasheet from Preliminary to Standard



Enabling Unlimited Possibilities™

Atmel Corporation

2325 Orchard Parkway
San Jose, CA 95131
USA

Tel: (+1) (408) 441-0311

Fax: (+1) (408) 487-2600

www.atmel.com

Atmel Asia Limited

Unit 01-5 & 16, 19F
BEA Tower, Millennium City 5
418 Kwun Tong Roa
Kwun Tong, Kowloon

HONG KONG

Tel: (+852) 2245-6100

Fax: (+852) 2722-1369

Atmel Munich GmbH

Business Campus
Parkring 4
D-85748 Garching b. Munich
GERMANY

Tel: (+49) 89-31970-0

Fax: (+49) 89-3194621

Atmel Japan G.K.

16F Shin-Osaki Kangyo Building
1-6-4 Osaki
Shinagawa-ku, Tokyo 141-0032
JAPAN

Tel: (+81) (3) 6417-0300

Fax: (+81) (3) 6417-0370

© 2012 Atmel Corporation. All rights reserved. / Rev.: 9225B–RFID–04/12

Atmel®, Atmel logo and combinations thereof, IDIC®, Enabling Unlimited Possibilities®, and others are registered trademarks or trademarks of Atmel Corporation or its subsidiaries. Other terms and product names may be trademarks of others.

Disclaimer: The information in this document is provided in connection with Atmel products. No license, express or implied, by estoppel or otherwise, to any intellectual property right is granted by this document or in connection with the sale of Atmel products. EXCEPT AS SET FORTH IN THE ATMEL TERMS AND CONDITIONS OF SALES LOCATED ON THE ATMEL WEBSITE, ATMEL ASSUMES NO LIABILITY WHATSOEVER AND DISCLAIMS ANY EXPRESS, IMPLIED OR STATUTORY WARRANTY RELATING TO ITS PRODUCTS INCLUDING, BUT NOT LIMITED TO, THE IMPLIED WARRANTY OF MERCHANTABILITY, FITNESS FOR A PARTICULAR PURPOSE, OR NON-INFRINGEMENT. IN NO EVENT SHALL ATMEL BE LIABLE FOR ANY DIRECT, INDIRECT, CONSEQUENTIAL, PUNITIVE, SPECIAL OR INCIDENTAL DAMAGES (INCLUDING, WITHOUT LIMITATION, DAMAGES FOR LOSS AND PROFITS, BUSINESS INTERRUPTION, OR LOSS OF INFORMATION) ARISING OUT OF THE USE OR INABILITY TO USE THIS DOCUMENT, EVEN IF ATMEL HAS BEEN ADVISED OF THE POSSIBILITY OF SUCH DAMAGES. Atmel makes no representations or warranties with respect to the accuracy or completeness of the contents of this document and reserves the right to make changes to specifications and products descriptions at any time without notice. Atmel does not make any commitment to update the information contained herein. Unless specifically provided otherwise, Atmel products are not suitable for, and shall not be used in, automotive applications. Atmel products are not intended, authorized, or warranted for use as components in applications intended to support or sustain life.