

Features

- Number of keys:
 - One
- Technology:
 - Patented spread-spectrum charge-transfer
- Key outline sizes:
 - 6 mm x 6 mm or larger (panel thickness dependent); widely different sizes and shapes possible
- Electrode design:
 - Solid or ring electrode shapes
- PCB layers required:
 - One
- Electrode materials:
 - Etched copper, silver, carbon, Indium Tin Oxide (ITO)
- Electrode substrates:
 - PCB, FPCB, plastic films, glass
- Panel materials:
 - Plastic, glass, composites, painted surfaces (low particle density metallic paints possible)
- Panel thickness:
 - Up to 50 mm glass, 20 mm plastic (electrode size and Cs dependent)
- Key sensitivity:
 - Settable via capacitor (Cs)
- Interface:
 - Digital output, active high
- Moisture tolerance:
 - Good
- Power:
 - 2.5V – 5.5V, 600 μ A single supply operation
- Package:
 - 8-pin SOIC RoHS compliant
- Signal processing:
 - Self-calibration, auto drift compensation, noise filtering
- Applications:
 - Light switches
 - Proximity sensors
 - Appliance control
 - Security systems
 - Access systems
 - Pointing devices
 - Elevator buttons
 - Consumer devices



QProx[®] Charge-transfer Touch Sensor

QT113B



1. Pinout and Schematic

1.1 Pinout Configuration

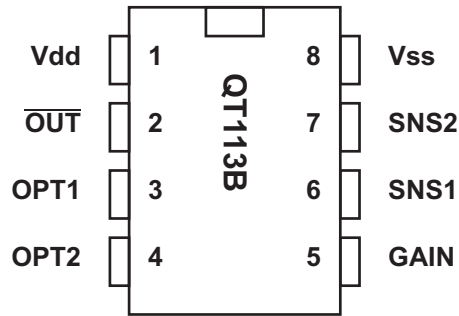

1.2 Pin Descriptions

Table 1-1. Pin Listing

Pin	Name	Type	Comments	If Unused, Connect To...
1	Vdd	P	Power	–
2	$\overline{\text{OUT}}$	O	Output state inverse – 0 when touched	–
3	OPT1	I	Option pin 1	–
4	OPT2	I	Option pin 2	–
5	GAIN	I	Gain setting	–
6	SNS1	I/O	Sense pin	–
7	SNS2	I/O	Sense pin	–
8	Vss	P	Supply ground	–

I Input only
 O Output only, push-pull

I/O Input and output
 P Ground or power

1.3 Schematic

Figure 1-1. Typical Circuit

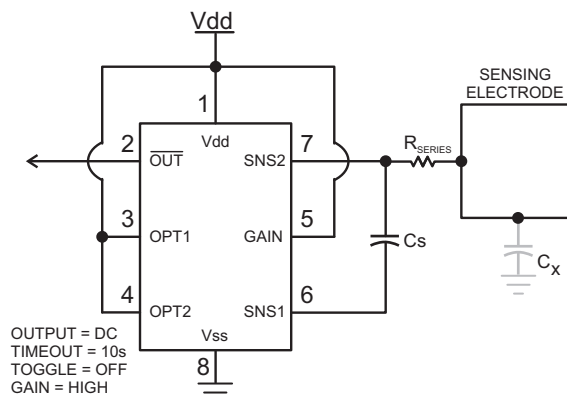

Re [Figure 1-1 on page 3](#) check the following sections for component values:

- [Section 4.1 on page 12](#): Cs capacitor
- [Section 5.2 on page 15](#): Voltage levels

2. Overview of the QT113B

2.1 Introduction

The QT113B charge-transfer (QT™) touch sensor is a self-contained digital IC capable of detecting near-proximity or touch. It will project a proximity sense field through air, and any dielectric like glass, plastic, stone, ceramic, and most kinds of wood. It can also turn small metal-bearing objects into intrinsic sensors, making them responsive to proximity or touch. This capability coupled with its ability to self-calibrate continuously can lead to entirely new product concepts.

It is designed specifically for human interfaces, like control panels, appliances, toys, lighting controls, or anywhere a mechanical switch or button may be found; it may also be used for some material sensing and control applications provided that the presence duration of objects does not exceed the recalibration timeout interval.

Power consumption is only 600 μ A in most applications. In most cases the power supply need only be minimally regulated, for example by Zener diodes or an inexpensive 3-terminal regulator. The QT113B requires only a common inexpensive capacitor in order to function.

The QT113B's RISC core employs signal processing techniques pioneered by Atmel®; these are specifically designed to make the device survive real-world challenges, such as “stuck sensor” conditions and signal drift.

The option-selectable toggle mode permits on/off touch control, for example for light switch replacement. The Atmel-pioneered HeartBeat™ signal is also included, allowing a microcontroller to monitor the health of the QT113B continuously if desired. By using the charge transfer principle, the IC delivers a level of performance clearly superior to older technologies in a highly cost-effective package.

The QT113B is a direct replacement for the QT113. The only circuit change required in most cases is the reduction of the value of the C_s capacitor to compensate for the fact that the QT113B is slightly more sensitive than the older part. A reduction by a factor of 2x is often required, but some experimentation is necessary to ascertain the correct value of C_s .

2.2 Basic Operation

The QT113B employs bursts of charge-transfer cycles to acquire its signal. Burst mode permits power consumption in the microamp range, dramatically reduces RF emissions, lowers susceptibility to EMI, and yet permits excellent response time. Internally the signals are digitally processed to reject impulse noise, using a 'consensus' filter which requires three consecutive confirmations of a detection before the output is activated.

The QT switches and charge measurement hardware functions are all internal to the QT113B (Figure 2-1 on page 4). A 14-bit single-slope switched capacitor analog-to-digital converter (ADC) includes both the required QT charge and transfer switches in a configuration that provides direct ADC conversion. The ADC is designed to dynamically optimize the QT burst length according to the rate of charge buildup on C_s , which in turn depends on the values of C_s , C_x , and V_{dd} . V_{dd} is used as the charge reference voltage. Larger values of C_x cause the charge transferred into C_s to rise more rapidly, reducing available resolution; as a minimum resolution is required for proper operation, this can result in dramatically reduced apparent gain. Conversely, larger values of C_s reduce the rise of differential voltage across it, increasing available resolution by permitting longer QT bursts. The value of C_s can thus be increased to allow larger values of C_x to be tolerated (see Appendix A on page 20).

The IC is responsive to both C_x and C_s , and changes in C_s can result in substantial changes in sensor gain.

Option pins allow the selection or alteration of several special features and sensitivity.

Figure 2-1. Internal Switching and Timing

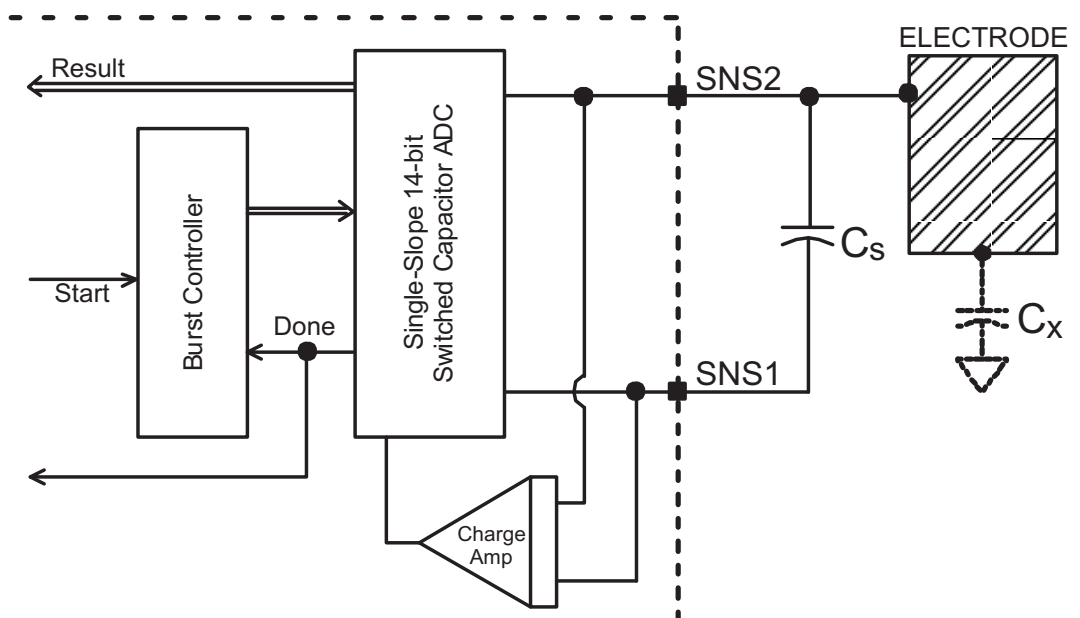

2.3 Electrode Drive

The internal ADC treats C_s as a floating transfer capacitor; as a result, the sense electrode can in theory be connected to either SNS1 or SNS2 with no performance difference. However the electrode should only be connected to pin SNS2 for optimum noise immunity.

In all cases the rule $C_s \gg C_x$ must be observed for proper operation; a typical load capacitance (C_x) ranges from 10-20 pF while C_s is usually around 10-50 nF.

Increasing amounts of C_x destroy gain; therefore it is important to limit the amount of stray capacitance on both SNS terminals, for example by minimizing trace lengths and widths and keeping these traces away from power or ground traces or copper pours.

The traces and any components associated with SNS1 and SNS2 will become touch sensitive and should be treated with caution to limit the touch area to the desired location.

A series resistor, R_{series} , should be placed inline with the SNS2 pin to the electrode to suppress ESD and EMC effects.

2.4 Electrode Design

2.4.1 Electrode Geometry and Size

There is no restriction on the shape of the electrode; in most cases common sense and a little experimentation can result in a good electrode design. The QT113B operates equally well with long, thin electrodes as with round or square ones; even random shapes are acceptable. The electrode can also be a 3-dimensional surface or object. Sensitivity is related to electrode surface area, orientation with respect to the object being sensed, object composition, and the ground coupling quality of both the sensor circuit and the sensed object.

If a relatively large electrode surface is desired, and if tests show that the electrode has more capacitance than the QT113B can tolerate, the electrode can be made into a sparse mesh (see [Figure 2-2](#)) having lower C_x than a solid plane. Sensitivity may even remain the same, as the sensor will be operating in a lower region of the gain curves.

2.4.2 Kirchoff's Current Law

Like all capacitance sensors, the QT113B relies on Kirchoff's Current Law (see [Figure 2-2](#)) to detect the change in capacitance of the electrode. This law as applied to capacitive sensing requires that the sensor's field current must complete a loop, returning back to its source in order for capacitance to be sensed. Although most designers relate to Kirchoff's law with regard to hardwired circuits, it applies equally to capacitive field flows. By implication it requires that the signal ground and the target object must both be coupled together in some manner for a capacitive sensor to operate properly. Note that there is no need to provide actual hardwired ground connections; capacitive coupling to ground (C_{x1}) is always sufficient, even if the coupling might seem very tenuous. For example, powering the sensor via an isolated transformer will provide ample ground coupling, since there is capacitance between the windings and/or the transformer core, and from the power wiring itself directly to "local earth". Even when battery powered, just the physical size of the PCB and the object into which the electronics is embedded will generally be enough to couple a few picofarads back to local earth.

Figure 2-2. Kirchoff's Current Law

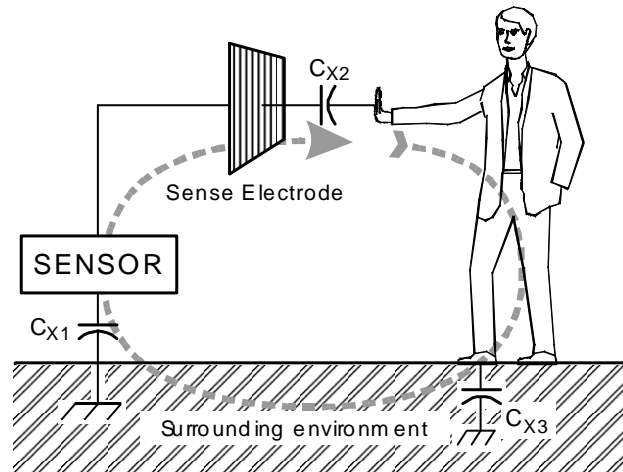

2.4.3 Virtual Capacitive Grounds

When detecting human contact (for example, a fingertip), grounding of the person is never required. The human body naturally has several hundred picofarads of “free space” capacitance to the local environment (C_{x3} in Figure 2-2), which is more than two orders of magnitude greater than that required to create a return path to the QT113B via earth. The QT113B’s PCB however can be physically quite small, so there may be little “free space” coupling (C_{x1} in Figure 2-2) between it and the environment to complete the return path. If the QT113B circuit ground cannot be earth grounded by wire, for example via the supply connections, then a virtual capacitive ground may be required to increase return coupling.

A virtual capacitive ground can be created by connecting the QT113B’s own circuit ground to:

- A nearby piece of metal or metallized housing;
- A floating conductive ground plane;
- Another electronic device (to which its output might be connected anyway).

Free-floating ground planes such as metal foils should maximize exposed surface area in a flat plane if possible. A square of metal foil will have little effect if it is rolled up or crumpled into a ball. Virtual ground planes are more effective and can be made smaller if they are physically bonded to other surfaces, for example a wall or floor.

2.4.4 Field Shaping

The electrode can be prevented from sensing in undesired directions with the assistance of metal shielding connected to circuit ground (see Figure 2-3). For example, on flat surfaces, the field can spread laterally and create a larger touch area than desired. To stop field spreading, it is only necessary to surround the touch electrode on all sides with a ring of metal connected to circuit ground; the ring can be on the same or opposite side from the electrode. The ring will kill field spreading from that point outwards.

Figure 2-3. Shielding Against Fringe Fields

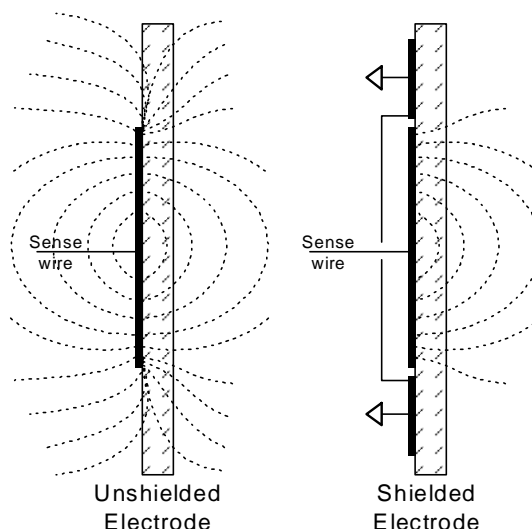

If one side of the panel to which the electrode is fixed has moving traffic near it, these objects can cause inadvertent detections. This is called walk-by and is caused by the fact that the fields radiate from either surface of the electrode equally well. Shielding in the form of a metal sheet or foil connected to circuit ground will prevent walk-by; putting a small air gap between the grounded shield and the electrode will keep the value of C_x lower to reduce loading and keep gain high.

2.4.5 Sensitivity

The QT113B can be set for one of two gain levels using option pin 5 (see [Table 3-1 on page 9](#)). This sensitivity change is made by altering the internal numerical threshold level required for a detection. Note that sensitivity is also a function of other things: like the value of C_s , electrode size and capacitance, electrode shape and orientation, the composition and aspect of the object to be sensed, the thickness and composition of any overlying panel material, and the degree of ground coupling of both sensor and object.

Increasing Sensitivity

In some cases it may be desirable to increase sensitivity further, for example when using the sensor with very thick panels having a low dielectric constant.

Sensitivity can often be increased by using a bigger electrode, reducing panel thickness, or altering panel composition. Increasing electrode size can have diminishing returns, as high values of C_x will reduce sensor gain (see the figures in [Appendix A on page 20](#)). The value of C_s also has a dramatic effect on sensitivity, and this can be increased in value with the tradeoff of reduced response time. Increasing the electrode's surface area will not substantially increase touch sensitivity if its diameter is already much larger in surface area than the object being detected. Panel material can also be changed to one having a higher dielectric constant, which will help propagate the field. Metal areas near the electrode will reduce the field strength and increase C_x loading.

Ground planes around and under the electrode and its SNS trace will cause high C_x loading and destroy gain. The possible signal-to-noise ratio benefits of ground area are more than negated by the decreased gain from the circuit, and so ground areas around electrodes are discouraged. Keep ground away from the electrodes and traces.

Decreasing Sensitivity

In some cases the QT113B may be too sensitive, even on low gain. In this case gain can be lowered further by decreasing Cs.

3. Detailed Operation

3.1 Signal Processing

3.1.1 Introduction

The QT113B processes all signals using 16-bit math, using a number of algorithms pioneered by Atmel. The algorithms are specifically designed to provide for high survivability in the face of numerous adverse environmental changes.

3.1.2 Drift Compensation Algorithm

Signal drift can occur because of changes in Cx and Cs over time. It is crucial that drift be compensated for, otherwise false detections, non-detections, and sensitivity shifts will follow.

Drift compensation (see [Figure 3-1 on page 8](#)) is performed by making the reference level track the raw signal at a slow rate, but only while there is no detection in effect. The rate of adjustment must be performed slowly, otherwise legitimate detections could be ignored. The QT113B drift compensates using a slew-rate limited change to the reference level; the threshold and hysteresis values are slaved to this reference.

Figure 3-1. Drift Compensation

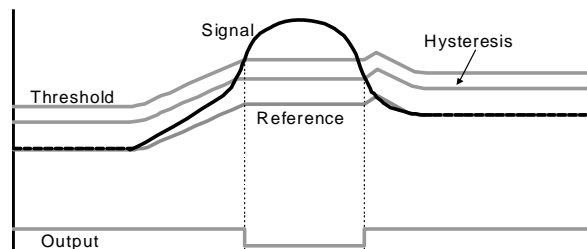

Once an object is sensed, the drift compensation mechanism ceases since the signal is legitimately high, and therefore should not cause the reference level to change.

The QT113B's drift compensation is asymmetric: the reference level drift-compensates in one direction faster than it does in the other. Specifically, it compensates faster for decreasing signals than for increasing signals. Increasing signals should not be compensated for quickly, since an approaching finger could be compensated for partially or entirely before even approaching the sense electrode. However, an obstruction over the sense pad, for which the sensor has already made full allowance for, could suddenly be removed leaving the sensor with an artificially elevated reference level and thus become insensitive to touch. In this latter case, the sensor will compensate for the object's removal very quickly, usually in only a few seconds.

With large values of Cs and small values of Cx, drift compensation will appear to operate more slowly than with the converse. Note that the positive and negative drift compensation rates are different.

3.1.3 Threshold Calculation

The internal threshold level is fixed at one of two setting as determined by [Table 3-1](#). These settings are fixed with respect to the internal reference level, which in turn will move in accordance with the drift compensation mechanism.

Table 3-1. Gain Setting Strap Options

Gain	Tie Pin 5 To...
High – 6 counts	Vdd
Low – 12 counts	Vss (Gnd)

The QT113B employs a hysteresis dropout below the threshold level of 17 percent of the delta between the reference and threshold levels.

3.1.4 Max On-Duration

If an object or material obstructs the sense pad the signal may rise enough to create a detection, preventing further operation. To prevent this, the sensor includes a timer which monitors detections. If a detection exceeds the timer setting, the timer causes the sensor to perform a full recalibration (when not set to infinite). This is known as the Max On-Duration feature.

After the Max On-Duration interval, the sensor once again functions normally to the best of its ability, given electrode conditions. There are two finite timeout durations available via strap option: 10 and 60 seconds (see [Table 3-2 on page 10](#)).

3.1.5 Detection Integrator

It is desirable to suppress detections generated by electrical noise or from quick brushes with an object. To accomplish this, the QT113B incorporates a detect integration counter that increments with each detection until a limit is reached, after which the output is activated. If no detection is sensed prior to the final count, the counter is reset immediately to zero. In the QT113B, the required count is 3.

The Detection Integrator can also be viewed as a “consensus filter”, that requires three successive detections to create an output.

3.1.6 Forced Sensor Recalibration

The QT113B has no recalibration pin; a forced recalibration is accomplished only when the device is powered up. However, supply drain is low so it is a simple matter to treat the entire IC as a controllable load; simply driving the QT113B’s Vdd pin directly from another logic gate or a microcontroller port (see [Figure 3-2](#)) will serve as both power and forced recalibration. The source resistance of most CMOS gates and microcontrollers are low enough to provide direct power without problem. Note that many 8051-based micros have only a weak pull-up drive capability and will require CMOS buffering. 74HC or 74AC series gates can directly power the QT113B, as can most other microcontrollers.

Figure 3-2. Powering From a CMOS Port Pin

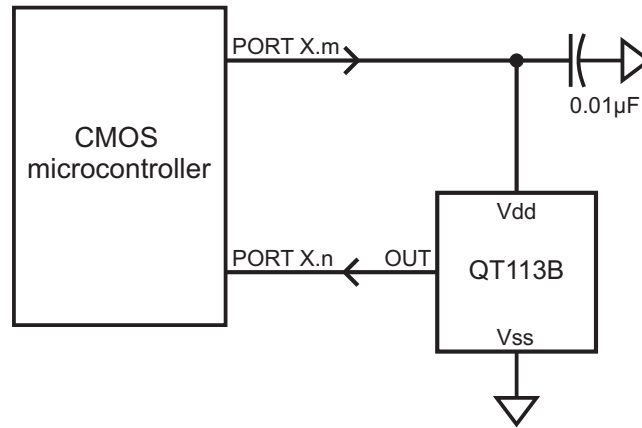

Option strap configurations are read by the QT113B only on power-up. Configurations can only be changed by powering the QT113B down and back up again; again, a microcontroller can directly alter most of the configurations and cycle power to put them in effect.

3.1.7 Response Time

The QT113B's response time is highly dependent on burst length, which in turn is dependent on Cs and Cx (see [Figure A-1](#) and [Figure A-2](#) on page 20). With increasing Cs, response time slows, while increasing levels of Cs reduce response time. [Figure A-3](#) on page 20 shows the typical effects of Cs and Cx on response time.

3.2 Output Features

3.2.1 Introduction

The QT113B is designed for maximum flexibility and can accommodate most popular sensing requirements. These are selectable using strap options on pins OPT1 and OPT2. All options are shown in [Table 3-2](#).

Table 3-2. Output Mode Strap Options

	Tie Pin 3 To...	Tie Pin 4 To...	Max On-duration
DC Out	Vdd	Vdd	10s
DC Out	Vdd	Gnd	60s
Toggle	Gnd	Gnd	10s
DC Out	Gnd	Vdd	Infinite

3.2.2 DC Mode Output

The output of the QT113B can respond in a DC mode, where the output is active-low upon detection. The output will remain active-low for the duration of the detection, or until the Max On-Duration expires (if not infinite), whichever occurs first. If a max on-duration timeout occurs first, the sensor performs a full recalibration and the output becomes inactive until the next detection.

In this mode, three Max On-Duration timeouts are available: 10 seconds, 60 seconds, and infinite.

Infinite timeout is useful in applications where a prolonged detection can occur and where the output must reflect the detection no matter how long. In infinite timeout mode, the designer should take care to be sure that drift in C_s , C_x , and V_{dd} do not cause the device to “stick on” inadvertently even when the target object is removed from the sense field.

3.2.3 Toggle Mode Output

This makes the sensor respond in an on/off mode like a flip flop. It is most useful for controlling power loads, for example in kitchen appliances, power tools, light switches.

Max On-Duration in Toggle mode is fixed at 10 seconds. When a timeout occurs, the sensor recalibrates but leaves the output toggle state unchanged.

3.2.4 HeartBeat™ Output

The QT113B output has a full-time HeartBeat™ health indicator superimposed on it. This operates by taking \overline{OUT} into a 3-state mode for 300 μs once after every QT burst. This output state can be used to determine that the sensor is operating properly, or, it can be ignored using one of several simple methods.

The HeartBeat indicator can be sampled by using a pull-down resistor on \overline{OUT} , and feeding the resulting negative-going pulse into a counter, flip flop, one-shot, or other circuit. Since \overline{OUT} is normally high, a pull-down resistor will create negative HeartBeat pulses (see [Figure 3-3 on page 11](#)) when the sensor is not detecting an object; when detecting an object, the output will remain low for the duration of the detection, and no HeartBeat pulse will be evident.

Figure 3-3. Getting HeartBeat Pulses With a Pull-down Resistor

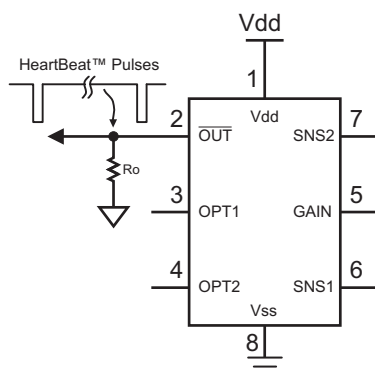

If the sensor is wired to a microcontroller as shown in [Figure 3-4](#), the microcontroller can reconfigure the load resistor to either ground or V_{dd} depending on the output state of the QT113B, so that the pulses are evident in either state.

Figure 3-4. Using a Micro to Obtain HeartBeat Pulses In Either Output State

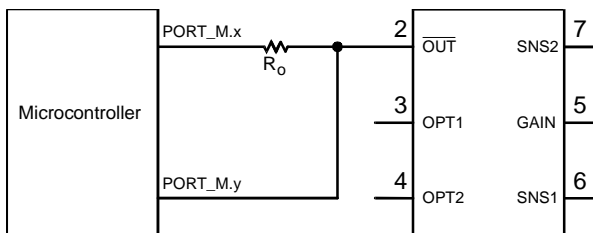

Electromechanical devices like relays will usually ignore this short pulse. The pulse also has too low a duty cycle to visibly affect LEDs. It can be filtered completely if desired, by adding an RC time constant to filter the output, or if interfacing directly and only to a high-impedance CMOS input, by doing nothing or at most adding a small noncritical capacitor from $\overline{\text{OUT}}$ to ground (see Figure 3-5).

Figure 3-5. Eliminating HB Pulses

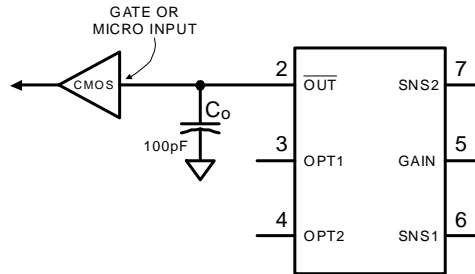

3.2.5 Output Drive

The QT113B's output is active low and can sink up to 5 mA of non-inductive current. If an inductive load is used, such as a small relay, the load should be diode clamped to prevent damage. When set to operate in a proximity mode (at high gain) the current should be limited to 1 mA to prevent gain-shifting side effects from occurring, which happens when the load current creates voltage drops on the die and bonding wires; these small shifts can materially influence the signal level to cause detection instability as described below.

Care should be taken when the QT113B and the load are both powered from the same supply, and the supply is minimally regulated. The QT113B derives its internal references from the power supply, and sensitivity shifts can occur with changes in V_{dd} , as happens when loads are switched on. This can induce detection "cycling", whereby an object is detected, the load is turned on, the supply sags, the detection is no longer sensed, the load is turned off, the supply rises and the object is reacquired, *ad infinitum*. To prevent this occurrence, the output should only be lightly loaded if the device is operated from an unregulated supply, for example, batteries. Detection "stiction", the opposite effect, can occur if a load is *shed* when $\overline{\text{OUT}}$ is active.

The output of the QT113B can directly drive a resistively limited LED. The LED should be connected with its cathode to the output and its anode towards V_{dd} , so that it lights when the sensor is active. If desired the LED can be connected from $\overline{\text{OUT}}$ to ground, and driven on when the sensor is inactive.

4. Wiring and Parts

4.1 Cs Sample Capacitors

Charge sampler C_s can be virtually any plastic film or medium-K ceramic capacitor. The acceptable C_s range is from 10 nF to 500 nF depending on the sensitivity required; larger values of C_s demand higher stability to ensure reliable sensing. Acceptable capacitor types include PPS film, polypropylene film, NPO/C0G ceramic, and X7R ceramic.

4.2 Option Strapping

The option pins OPT1 and OPT2 should never be left floating. If they are floated, the device will draw excess power and the options will not be properly read on power-up. Intentionally, there are no pull-up resistors on these lines, since pull-up resistors add to power drain if tied low.

The Gain input should be connected to either Vdd or Gnd.

[Table 3-1 on page 9](#) and [Table 3-2 on page 10](#) show the option strap configurations available.

4.3 Power Supply, PCB Layout

See [Section 5.2 on page 15](#) for the power supply range. At 3 volts current drain averages less than 600 μA in most cases, but can be higher if Cs is large. Increasing Cx values will actually *decrease* power drain. Operation can be from batteries, but be cautious about loads causing supply droop (see [Section 3.2.5 on page 12](#)).

As battery voltage sags with use or fluctuates slowly with temperature, the QT113B will track and compensate for these changes automatically with only minor changes in sensitivity.

If the power supply is shared with another electronic system, care should be taken to assure that the supply is free of digital spikes, sags, and surges which can adversely affect the QT113B. The QT113B will track slow changes in Vdd, but it can be affected by rapid voltage steps.

if desired, the supply can be regulated using a conventional low current regulator, for example CMOS regulators that have low quiescent currents. Bear in mind that such regulators generally have very poor transient line and load stability; in some cases, shunting Vdd to Vss with a 4.7 k Ω resistor to induce a continuous current drain can have a very positive effect on regulator performance.

Parts placement: The chip should be placed to minimize the SNS2 trace length to reduce low frequency pickup, and to reduce stray Cx which degrades gain. The Cs and Rseries resistors (see [Figure 1-1 on page 3](#)) should be placed as close to the body of the chip as possible so that the SNS2 trace between Rseries and the SNS2 pin is very short, thereby reducing the antenna-like ability of this trace to pick up high frequency signals and feed them directly into the chip.

For best EMC performance the circuit should be made entirely with SMT components.

SNS trace routing: Keep the SNS2 electrode trace (and the electrode itself) away from other signal, power, and ground traces including over or next to ground planes. Adjacent switching signals can induce noise onto the sensing signal; any adjacent trace or ground plane next to or under either SNS trace will cause an increase in Cx load and desensitize the device.

For proper operation a 100nF (0.1 μF) ceramic bypass capacitor must be used directly between Vdd and Vss; the bypass capacitor should be placed very close to the device's power pins.

4.4 ESD Protection

The QT113B includes internal diode protection on its pins to absorb and protect the device from most induced discharges, up to 20 mA. The electrode should always be insulated against direct ESD; a glass or plastic panel is usually enough as a barrier to ESD. Glass breakdown voltages are typically over 10 kV per mm thickness.

ESD protection can be enhanced by adding a series resistor R_{series} (see [Figure 1-1 on page 3](#)) in line with the electrode, of value between 1 k Ω and 50 k Ω . The optimal value depends on the amount of load capacitance C_x ; a high value of C_x means R_{series} has to be low. The pulse waveform on the electrode should be observed on an oscilloscope, and the pulse should look very flat just before the falling edge. If the pulse voltage never flattens, the gain of the sensor is reduced and there can be sensing instabilities.

R_{series} and C_s should both be placed very close to the chip.

The use of semiconductor transient protection devices, Zeners, or MOV's on the sense lead is not advised; these devices have extremely large amounts of parasitic capacitance which will swamp the QT113B and render it unstable or diminish gain.

4.5 EMC Issues

External AC fields (EMI) due to RF transmitters or electrical noise sources can cause false detections or unexplained shifts in sensitivity.

The influence of external fields on the sensor is reduced by means of the R_{series} described in [Section 4.4 on page 14](#). The C_s capacitor and R_{series} (see [Figure 1-1 on page 3](#)) form a natural low-pass filter for incoming RF signals; the roll-off frequency of this network is defined by:

$$F_R = \frac{1}{2\pi R_{series} C_s}$$

If for example $C_s = 22$ nF, and $R_{series} = 10$ k Ω , the rolloff frequency to EMI is 723Hz, vastly lower than any credible external noise source (except for mains frequencies). However, R_{series} and C_s must both be placed very close to the body of the IC so that the lead lengths between them and the IC do not form an unfiltered antenna at very high frequencies.

5. Specifications

5.1 Absolute Maximum Specifications

Operating temperature	As designated by suffix
Storage temperature	-55°C to +125°C
Vdd	-0.5 to +6V
Max continuous pin current, any control or drive pin	±40 mA
Voltage forced onto any pin	-0.6V to (Vdd + 0.6) Volts
<p>CAUTION: Stresses beyond those listed under <i>Absolute Maximum Specifications</i> may cause permanent damage to the device. This is a stress rating only and functional operation of the device at these or other conditions beyond those indicated in the operational sections of this specification is not implied. Exposure to absolute maximum specification conditions for extended periods may affect device reliability.</p>	

5.2 Recommended Operating Conditions

Vdd	+2.5V to 5.5V
Operating temperature range	-40°C to +85°C
Short-term supply ripple + noise	±20 mV
Long-term supply stability	±100 mV
Cs value	100 nF to 500 nF
Cx value	0 pF to 100 pF

5.3 DC Specifications

Vdd = 3.0V, Cs = 10 nF, Cx = 5 pF, Ta = recommended range, unless otherwise noted

Parameter	Description	Minimum	Typical	Maximum	Units	Notes
I _{DD}	Supply current		1,000	2,500	μA	
V _{DDS}	Supply turn-on slope	100			V/s	Required for proper startup
V _{IL}	Low input logic level			0.2V _{dd}	V	OPT1, OPT2
V _{HL}	High input logic level	0.9V _{dd}			V	OPT1, OPT2
V _{OL}	Low output voltage			0.6	V	OUT, 4mA sink
V _{OH}	High output voltage	V _{dd} -0.7			V	$\overline{\text{OUT}}$, 1mA source
I _{IL}	Input leakage current			±1	μA	OPT1, OPT2
A _R	Acquisition resolution		9	14	bits	
S	Sensitivity range	1,000		10	fF	Sensitivity depends on value of Cx and Cs. Refer to Figure A-1 and Figure A-2 on page 20.

5.4 AC Specifications

V_{dd} = 3.0V, T_a = recommended range

Parameter	Description	Minimum	Typical	Maximum	Units	Notes
T _{RC}	Recalibration time		330		ms	Cs, Cx dependent
T _{PC}	Charge-transfer duration		1.95		μs	
T _{PT}	Cx reset duration		2.9		μs	
T _{BS}	Burst spacing interval	4.9		156	ms	Cs = 10 nF to 500 nF; Cx = 0
T _{BL}	Burst length	3.1		154	ms	Cs = 10 nF to 500 nF; Cx = 0
T _R	Response time		30		ms	Cx = 10 pF; See Figure A-3 on page 20
T _{HB}	Heartbeat pulse width		310		μs	
F _Q	Burst frequency		172		kHz	

5.4.1 Signal Processing

Description	Min	Typ	Max	Units	Notes
Threshold differential	6 or 12			counts	Option pin selected
Hysteresis	17			%	Percentage of signal threshold
Consensus filter length	3			samples	
Positive drift compensation rate		1,000		ms/level	
Negative drift compensation rate		100		ms/level	
Post-detection recalibration timer duration	10, 60, infinite			seconds	Option pin selected

5.5 Mechanical Dimensions

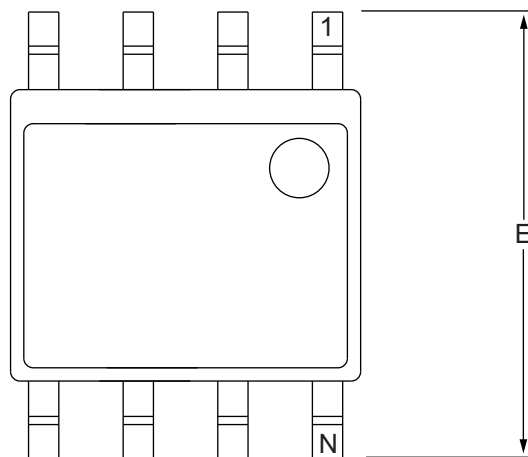

Top View

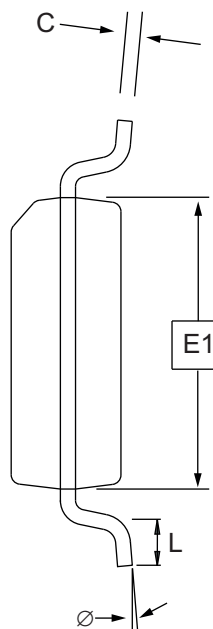

End View

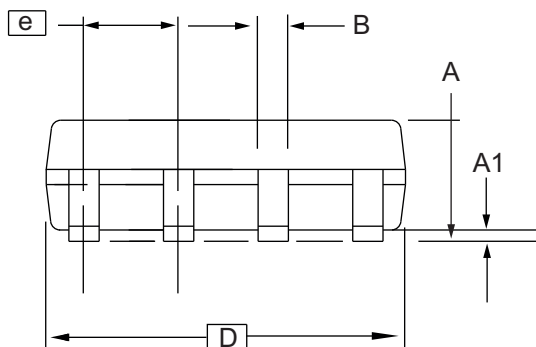

Side View

COMMON DIMENSIONS
(Unit of Measure = mm)

SYMBOL	MIN	NOM	MAX	NOTE
A	1.35	–	1.75	
A1	0.10	–	0.25	
b	0.31	–	0.51	
C	0.17	–	0.25	
D	4.80	–	5.00	
E1	3.81	–	3.99	
E	5.79	–	6.20	
e	1.27 BSC			
L	0.40	–	1.27	
∅	0°	–	8°	

Note: These drawings are for general information only. Refer to JEDEC Drawing MS-012, Variation AA for proper dimensions, tolerances, datums, etc.

10/7/03

ATMEL 1150 E. Cheyenne Mtn. Blvd.
Colorado Springs, CO 80906

TITLE
8S1, 8-lead (0.150" Wide Body), Plastic Gull Wing
Small Outline (JEDEC SOIC)

DRAWING NO.
8S1

REV.
B

5.6 Marking

Either part marking is used.

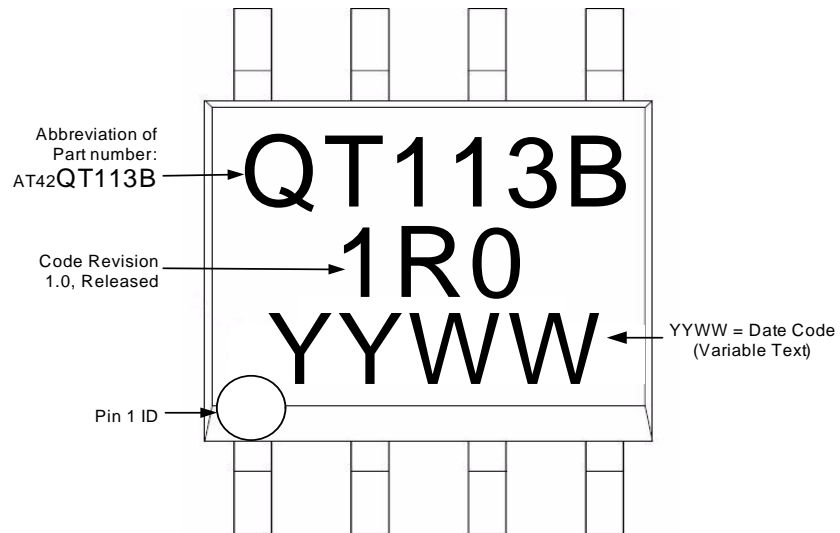
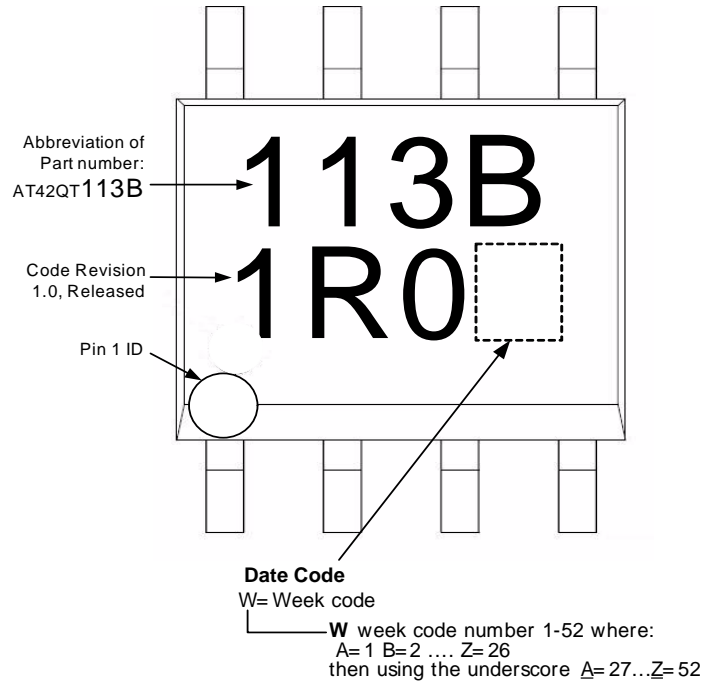

5.7 Part Number

Part Number	Description
QT113B-ISG	8-pin SOIC RoHS compliant

5.8 Moisture Sensitivity Level (MSL)

MSL Rating	Peak Body Temperature	Specifications
MSL3	260°C	IPC/JEDEC J-STD-020

Appendix A.

Figure A-1. Typical threshold Sensitivity vs Cx, High Gain, At Selected Values of Cs; Vdd = 3.0V

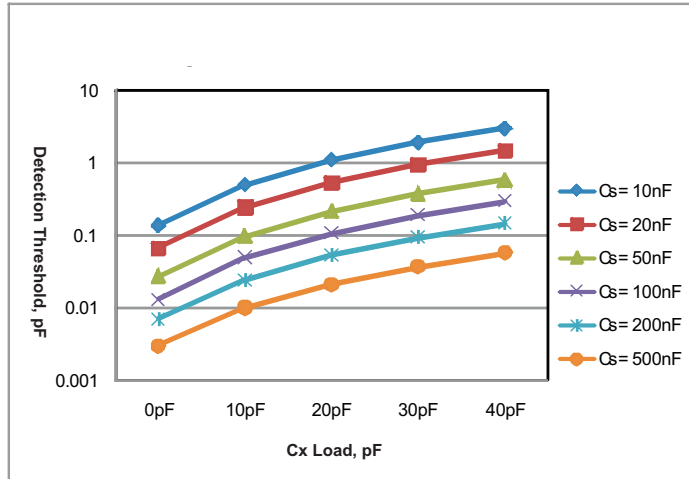

Figure A-2. Typical threshold Sensitivity vs Cx, Low Gain, At Selected Values of Cs; Vdd = 3.0V

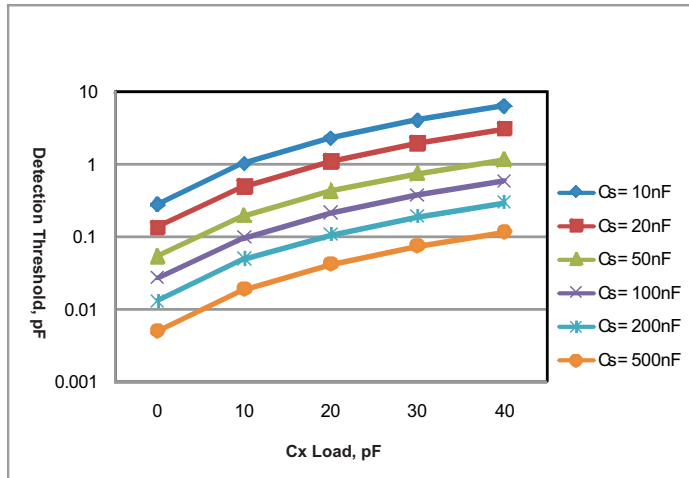
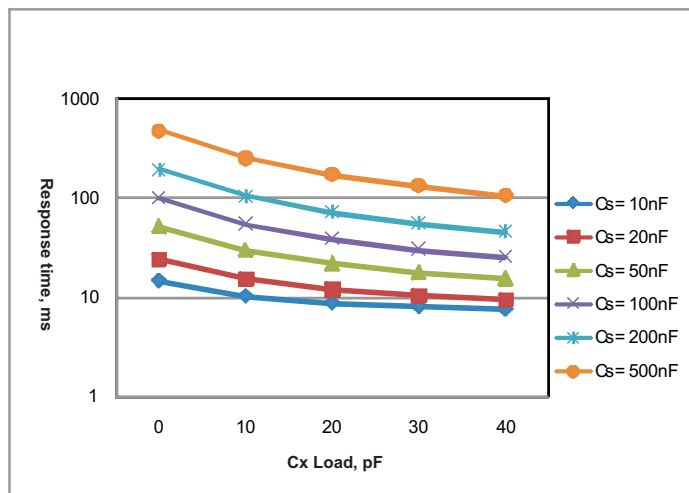

Figure A-3. Typical Response Times vs Cx; Vdd = 3.0V



Revision History

Revision Number	History
Revision A – February 2009	<ul style="list-style-type: none"> • Initial release for chip revision 1.0.
Revision B – September 2010	<ul style="list-style-type: none"> • Address information on back page updated. • Regulator information removed. • Orderable part number corrected. • This version of datasheet not issued.
Revision C – June 2011	<ul style="list-style-type: none"> • QProx changed from QProx™ to QProx®. • Copyright updated.



Headquarters

Atmel Corporation

2325 Orchard Parkway
San Jose, CA 95131
USA
Tel: (+1) (408) 441-0311
Fax: (+1) (408) 487-2600

International

Atmel Asia

Unit 01-05 & 16, 19F
BEA Tower, Millennium City 5
418 Kwun Tong Road
Kwun Tong
Kowloon
HONG KONG
Tel: (+852) 2245-6100
Fax: (+852) 2722-1369

Atmel Munich GmbH

Business Campus
Parking 4
D- 85748 Garching b.
MUNICH
Tel.: (+49) 89-31970-111
Fax: (+49) 89-3194621

Atmel Japan

9F, Tonetsu Shinkawa Bldg.
1-24-8 Shinkawa
Chuo-ku, Tokyo 104-0033
JAPAN
Tel: (+81) 3-3523-3551
Fax: (+81) 3-3523-7581

Touch Technology Division

1560 Parkway
Solent Business Park
Whiteley
Fareham
Hampshire
PO15 7AG
UNITED KINGDOM
Tel: (+44) 844 894 1920
Fax: (+44) 1489 557 066

Product Contact

Web Site

www.atmel.com

Technical Support

touch@atmel.com

Sales Contact

www.atmel.com/contacts

Literature Requests

www.atmel.com/literature

Disclaimer: The information in this document is provided in connection with Atmel products. No license, express or implied, by estoppel or otherwise, to any intellectual property right is granted by this document or in connection with the sale of Atmel products. **EXCEPT AS SET FORTH IN ATMEL'S TERMS AND CONDITIONS OF SALE LOCATED ON ATMEL'S WEB SITE, ATMEL ASSUMES NO LIABILITY WHATSOEVER AND DISCLAIMS ANY EXPRESS, IMPLIED OR STATUTORY WARRANTY RELATING TO ITS PRODUCTS INCLUDING, BUT NOT LIMITED TO, THE IMPLIED WARRANTY OF MERCHANTABILITY, FITNESS FOR A PARTICULAR PURPOSE, OR NON-INFRINGEMENT. IN NO EVENT SHALL ATMEL BE LIABLE FOR ANY DIRECT, INDIRECT, CONSEQUENTIAL, PUNITIVE, SPECIAL OR INCIDENTAL DAMAGES (INCLUDING, WITHOUT LIMITATION, DAMAGES FOR LOSS OF PROFITS, BUSINESS INTERRUPTION, OR LOSS OF INFORMATION) ARISING OUT OF THE USE OR INABILITY TO USE THIS DOCUMENT, EVEN IF ATMEL HAS BEEN ADVISED OF THE POSSIBILITY OF SUCH DAMAGES.** Atmel makes no representations or warranties with respect to the accuracy or completeness of the contents of this document and reserves the right to make changes to specifications and product descriptions at any time without notice. Atmel does not make any commitment to update the information contained herein. Unless specifically provided otherwise, Atmel products are not suitable for, and shall not be used in, automotive applications. Atmel's products are not intended, authorized, or warranted for use as components in applications intended to support or sustain life.

© 2009–2011 Atmel Corporation. All rights reserved. Atmel®, Atmel logo and combinations thereof, QProx® and others are registered trademarks, QT™, HeartBeat™, and others are trademarks of Atmel Corporation or its subsidiaries. Other terms and product names may be registered trademarks or trademarks of others.