

Atmel LED Drivers

MSL4163/MSL4164

16-string, White and RGB LED Drivers with Adaptive Power Control, EEPROM, and SPI/I²C/SMBus Serial Interface

Datasheet Brief



Atmel LED Drivers-MSL4163/MSL4164

16-string, White and RGB LED Drivers with Adaptive Power Control, EEPROM, and SPI/I²C/SMBus Serial Interface

General Description

The Atmel® LED Drivers-MSL4163 and MSL4164 compact, high-power LED string drivers use internal current control MOSFETs to sink up to 100mA per string, with current accuracy and matching better than 3%. The MSL4163/4 drive 16 parallel strings of 10 white LEDs each, for a total of 160 white LEDs per device. Sixteen interconnected devices control up to 2560 white LEDs.

The MSL4164 features a 20MHz SPI bus, and the MSL4163 offers a 1MHz I²C serial interface. Both interfaces support video frame-by-frame LED string intensity control for up to 16 interconnected devices to allow active area dimming. The devices include an advanced PWM engine that easily synchronizes to a video signal, and per-string phase adjustment to reduce unwanted LCD artifacts such as motion blur. Additionally, an on-chip EEPROM allows the power-up defaults to be customized through the serial interface.

The MSL4163/4 adaptively control the DC-DC converters that power the LED strings, using Atmel's Adaptive SourcePower™ technology. These efficiency optimizers minimize power use, while maintaining LED current accuracy.

A unique combination of peak current controls and pulse width management offer simple, full-screen brightness control, versatile area dimming, and a consistent white point. One external resistor sets the global peak reference current for all LED strings, and global peak current fine-tuning is available through an 8-bit register. Global string drive pulse width is adjusted with an 8-bit global intensity register, and individual string pulse width is modulated with 12-bit registers.

The MSL4163/4 feature fault monitoring of open circuit, short circuit, loss of video sync, and over-temperature conditions, and provide a fault output to notify the system controller. Detailed fault status and control are available through the serial interface.

The MSL4163/4 are offered in 6 x 6 x 0.75mm, 40-pin TQFN packages and operate over a -40°C to 85°C temperature range.

Applications

Long Life, Efficient LED Backlighting for:

- Televisions and Desktop Monitors
- Medical and Industrial Instrumentation
- Automotive Audio-visual Displays

Channel Signs

Architectural Lighting

Ordering Information

16-CHANNEL LED STRING DRIVERS		
PART	INTERFACE	PACKAGE
MSL4163BT	I ² C	40-pin, 6 x 6 x 0.75mm TQFN
MSL4164BT	SPI	40-pin, 6 x 6 x 0.75mm TQFN

Atmel LED Drivers-MSL4163/MSL4164

16-string, White and RGB LED Drivers with Adaptive Power Control, EEPROM, and SPI/I²C/SMBus Serial Interface

Key Features

- 12-bit PWM String Dimming Operates at 240Hz
- Fast Serial Interfaces Support up to 16 Devices per Bus:
 - MSL4164: 20MHz SPI
 - MSL4163: 1MHz I²C
- 8-bit Adaptive Power Correction Maximizes Efficiency of up to Three String Power Supplies
- Drives 16 Parallel LED Strings of 10 White LEDs Each, for up to 2560 White LEDs per Serial Bus
- Supports Adaptive, Real-time Area Dimming for Highest Dynamic Range LCD TVs and Monitors
- Programmable String Phase Reduces Motion Blur
- Global Intensity Control via Serial Interface
- 100mA Peak, 60mA Average LED String Current
- Single Resistor Sets Peak Current for all LED Strings
- ±3% Current Accuracy and Current Balance
- Video Frame (Vsync) and Line (Hsync) Sync Inputs
- Sync Loss Detectors Optionally Disable LED Strings
- Multiple MSL4163/4s Share String Power Supplies and Automatically Negotiate the Optimum Supply Voltage
- EEPROM Allows Customized Power-on Defaults
- Less than 1µA LED String-off Leakage Current
- String Open Circuit and LED Short Circuit Detection with Adjustable Short Circuit Threshold
- Individual Fault Detection Enable for Each String
- Over-temperature Shutoff Protection
- -40°C To +85°C Operating Temperature Range
- 4kv HBM ESD Rated String Drive Outputs

Application Circuit

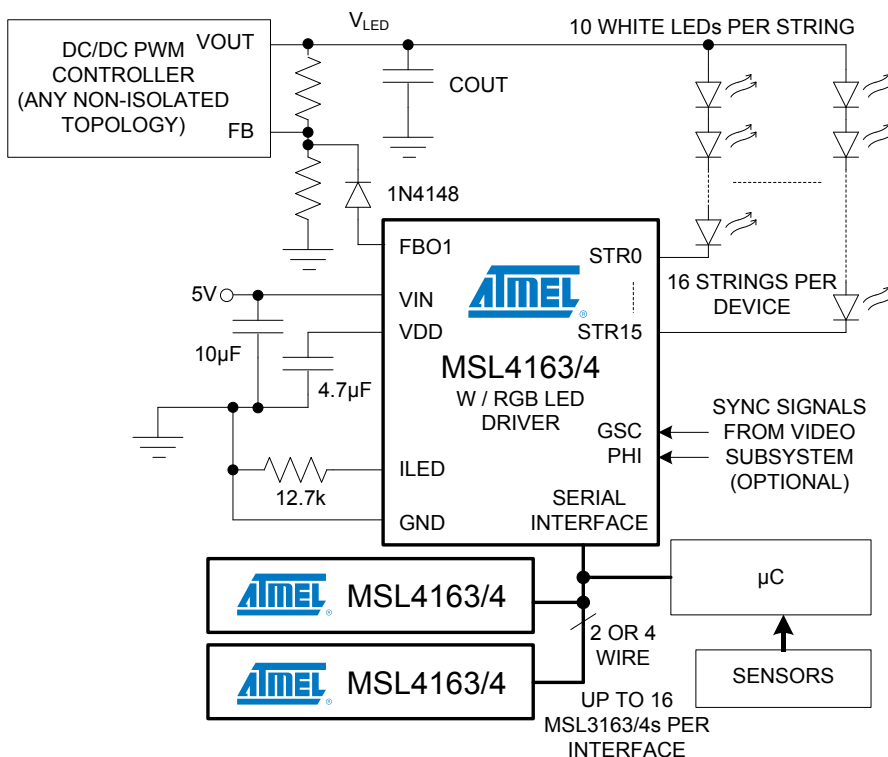



Package Pin-out

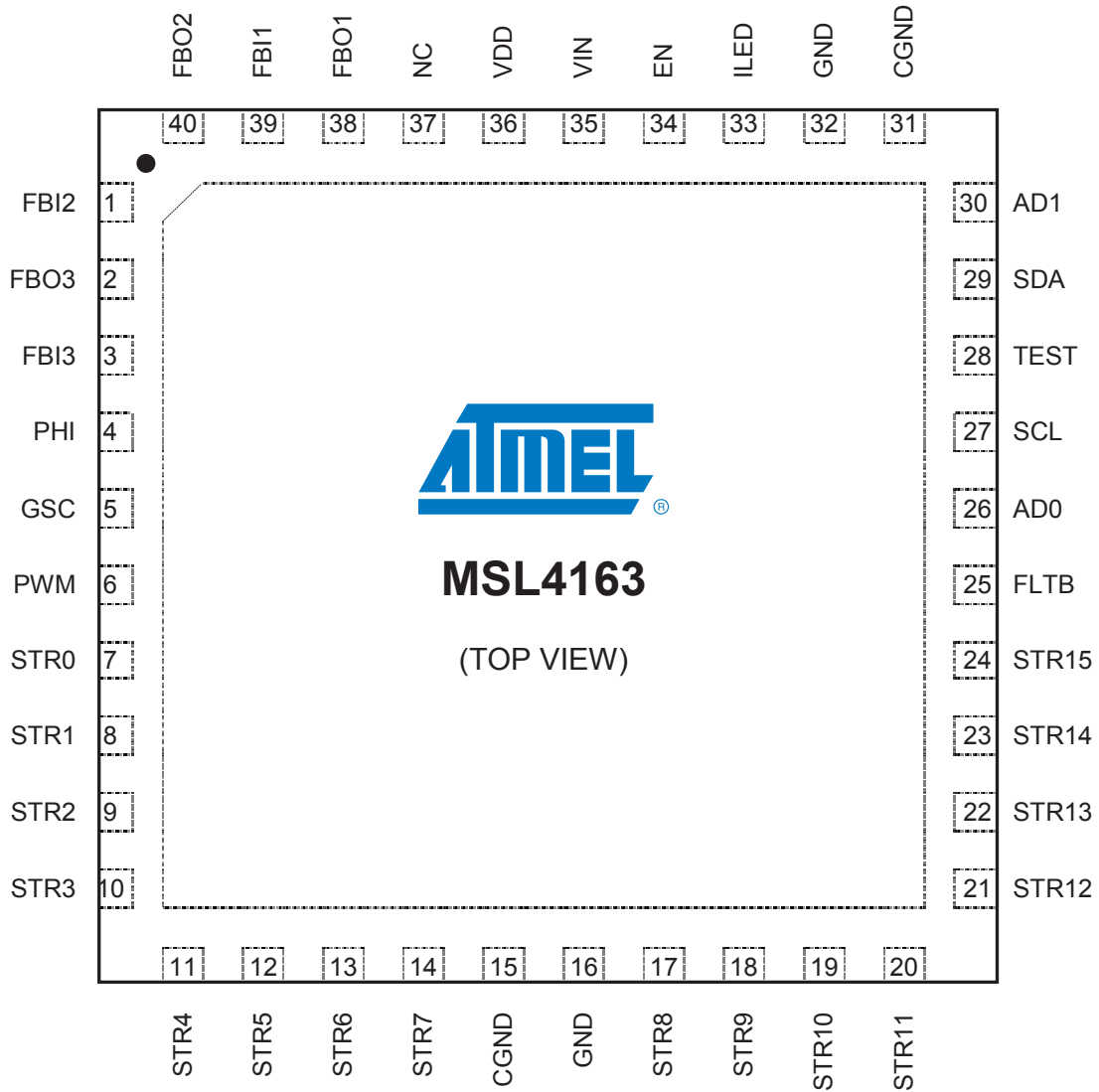

Figure 1. Atmel LED Driver-MSL4163 Pin-out, 40-pin TQFN.

Atmel LED Drivers-MSL4163/MSL4164

16-string, White and RGB LED Drivers with Adaptive Power Control, EEPROM, and SPI/I²C/SMBus Serial Interface

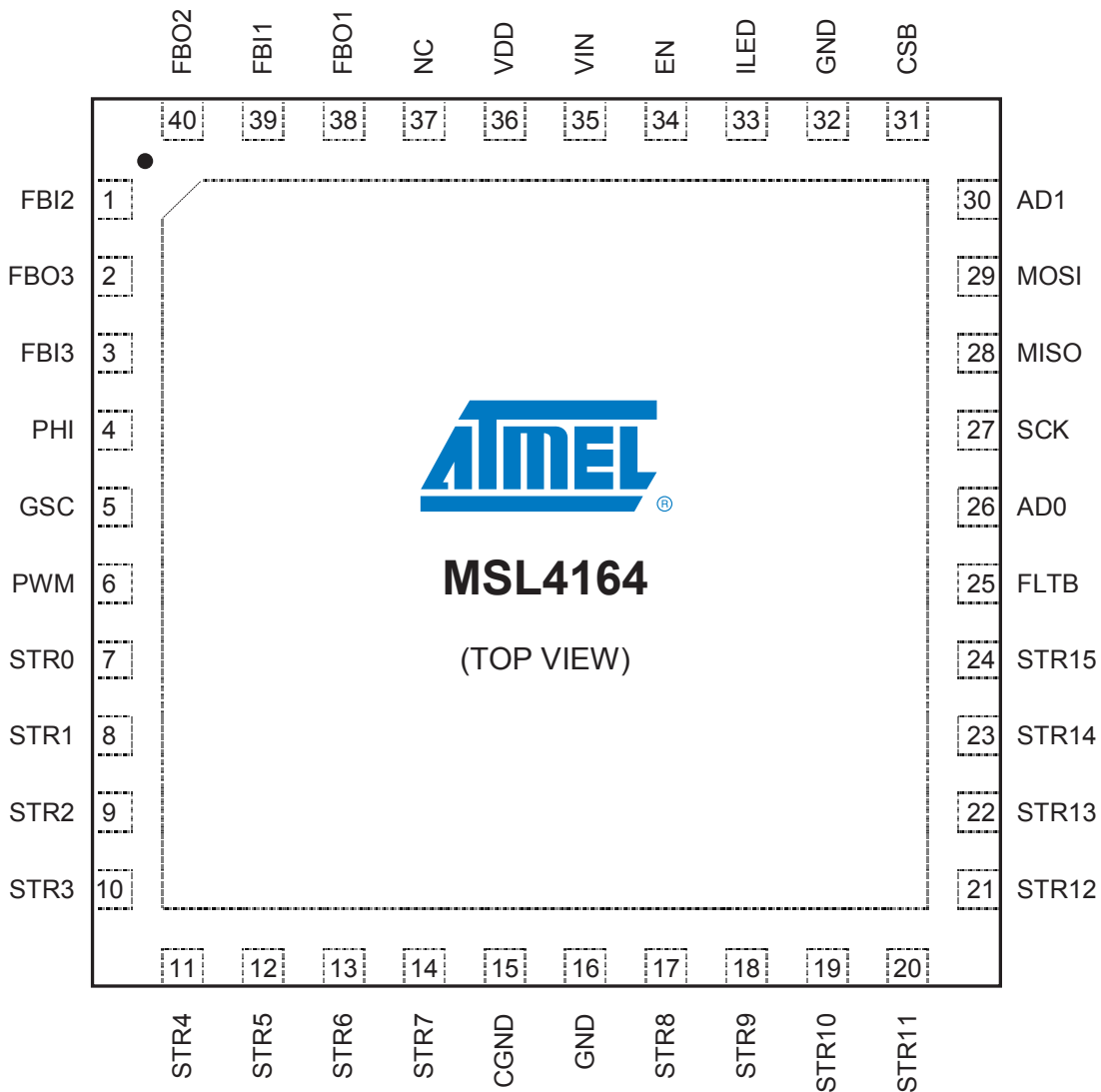
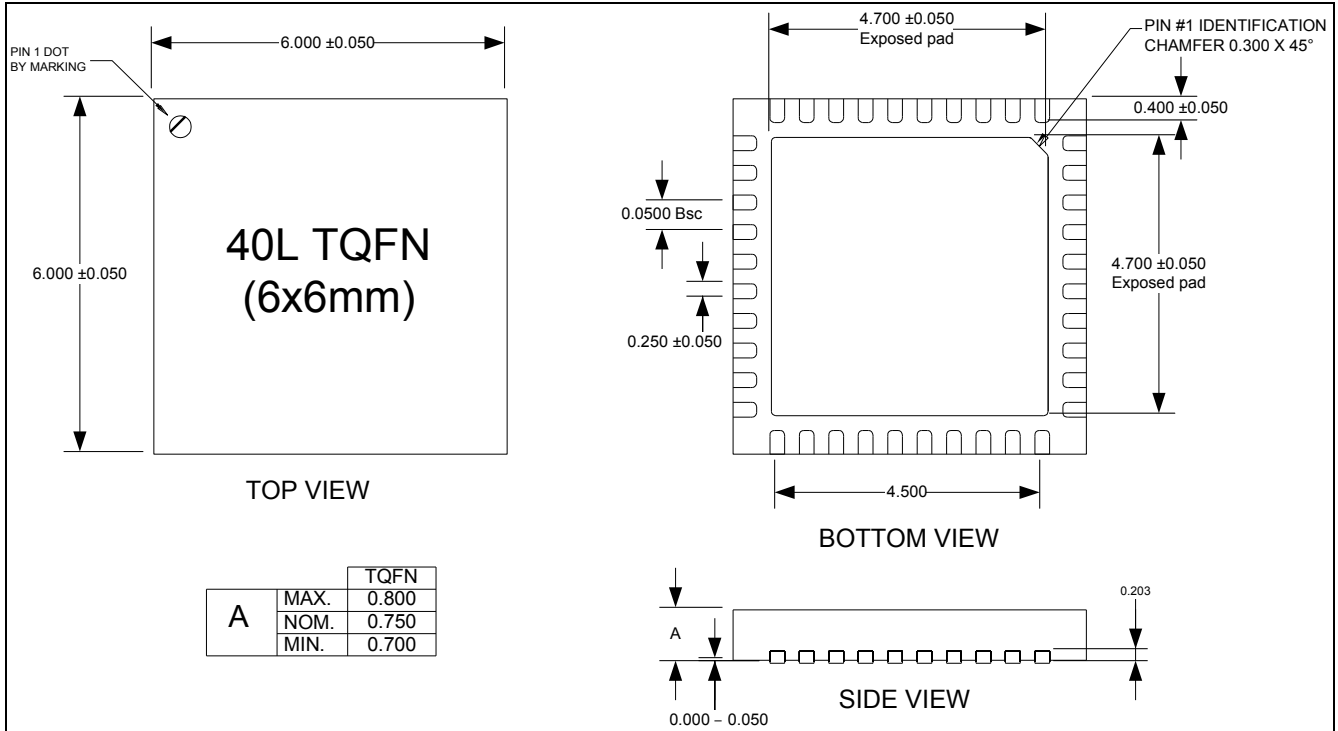

Figure 2. Atmel LED Driver-MSL4164 Pin-out, 40-pin TQFN.



Figure 3. Package Dimensions: 40-pin, 6mm x 6mm x 0.75mm TQFN (0.5mm Pin Pitch) with Exposed Pad.



Atmel LED Drivers-MSL4163/MSL4164

16-string, White and RGB LED Drivers with Adaptive Power Control, EEPROM, and SPI/I²C/SMBus Serial Interface

Package Pin-out

Table 1. Pin Descriptions

PIN	PIN NAME		PIN DESCRIPTION
	MSL4163	MSL4164	
1	FBI2	FBI2	Efficiency Optimizer input 2 Connect FBI2 to FBO2 of the next device when chaining devices (Figure 7). If unused, connect FBI2 to GND.
2	FBO3	FBO3	Efficiency Optimizer output 3 Connect FBO3 to the third power supply's feedback node or to FBI3 of the previous device when chaining devices (Figure 7). If unused, connect FBO3 to GND.
3	FBI3	FBI3	Efficiency Optimizer input 3 Connect FBI3 to FBO3 of the next device when chaining devices (Figure 7). If unused, connect FBI3 to GND.
4	PHI	PHI	Phase synchronization input Drive PHI with an external signal from 40Hz to 10kHz to synchronize the MSL4163/4 clock. PHI is typically the VSYNC signal input.
5	GSC	GSC	Gate shift clock input Drive GSC with the gate shift clock of the video signal from 0 to 10MHz. GSC is typically the HSYNC signal input.
6	PWM	PWM	PWM input PWM allows direct external control of the brightness of all LED strings. The PWM input may also be used as a gate signal for the output of the PWM engine. Drive PWM with a pulse-width modulated signal with duty ratio ranging from 0% to 100% and frequency up to 5kHz. When not configured for use as an input, PWM is high impedance.
7 - 14, 17 - 24	STR0 thru STR15	STR0 thru STR15	LED string current sink outputs Connect the cathode of the n th string's bottom LEDs to STRn. Connect unused STRn outputs to GND.
15	CGND	CGND	Connect to ground Connect CGND to GND and to EP with short, wide traces.
16, 32	GND	GND	Signal ground Connect all GNDs to system ground and to EP with short, wide traces.
25	FLT B	FLT B	Fault indication output (active low) Open drain output FLT B sinks current to GND whenever a fault condition is verified. Toggle EN low or read the fault registers to clear FLT B. Once cleared, FLT B reasserts if the fault conditions persist.
26,30	AD0, AD1	AD0, AD1	Slave ID selection inputs Connect AD1 and AD0 to GND through resistors to set the device address for the serial interface.
27	SCL	SCK	MSL4163: I²C serial clock input SCL is the clock input for the I ² C serial interface.
			MSL4164: SPI serial shift clock SCK is the clock input for the SPI bus.
28	TEST	MISO	MSL4163: Factory test I/O Factory test. Make no electrical connection to TEST.
			MSL4164: Master input slave output MISO is the SPI serial data output.



Table 1. Pin Descriptions

PIN	PIN NAME		PIN DESCRIPTION
	MSL4163	MSL4164	
29	SDA	MOSI	MSL4163: I²C serial data I/O SDA is the data I/O for the I ² C serial interface.
			MSL4164: Master input slave output MOSI is the SPI serial data input.
31	GND	CSB	MSL4163: Ground. Connect GND to system ground and to EP with short, wide traces.
			MSL4164: Chip select (active low) CSB is the chip select input for SPI transactions. CSB is active low.
33	ILED	ILED	Maximum LED string current setting input Connect a resistor from ILED to GND to set the full-scale LED string current for all strings, using $I_{\text{STRING}} = 762 / R_{\text{ILED}}$. For example, connect a 12.7kΩ resistor to GND to set a 60mA maximum sink current through each LED string.
34	EN	EN	Enable input (active high) Drive EN high to turn on the MSL4163/4, and drive EN low to turn off the MSL4163/4. For automatic start-up, connect EN to VIN. When EN is low, the entire device, including the serial interface, is turned off. Driving EN high initiates a boot load of the EEPROM data into the control registers, simulating a cold start-up.
35	VIN	VIN	Supply voltage input Connect a 5V supply to VIN. Bypass VIN to GND with a 10μF ceramic capacitor placed close to VIN.
36	VDD	VDD	2.5V internal LDO regulator output VDD powers internal logic. Bypass VDD to GND with a 4.7μF ceramic capacitor placed close to VDD.
37	NC	NC	No connection Leave NC unconnected.
38	FBO1	FBO1	Efficiency Optimizer output 1 Connect FBO1 to the first power supply's feedback node or to FBI1 of the previous device when chaining devices (Figure 7). If unused, connect FBO1 to GND.
39	FBI1	FBI1	Efficiency Optimizer input 1 Connect FBI1 to FBO1 of the next device when chaining devices (Figure 7). If unused, connect FBI1 to GND.
40	FBO2	FBO2	Efficiency Optimizer output 2 Connect FBO2 to the second power supply's feedback node or to FBI2 of the previous device when chaining devices (Figure 7). If unused, connect FBO2 to GND.
EP	EP	EP	Exposed pad, power ground EP is the path that the string currents take to ground. EP also provides thermal relief for the die. Provide large traces from EP back to the string power supplies. Also connect EP to system ground and to GND using short, wide traces.

Atmel LED Drivers-MSL4163/MSL4164

16-string, White and RGB LED Drivers with Adaptive Power Control, EEPROM, and SPI/I²C/SMBus Serial Interface

Absolute Maximum Ratings

Voltage (With Respect to GND, CGND = EP = GND)

VIN, EN	-0.3V to +6V
VDD.....	-0.3V to +2.75V
MSL4163: SDA, SCL	-0.3V to +6V
MSL4164: MISO, MOSI, CSB, SCK	-0.3V to (VIN + 0.3V)
FLTB	-0.3V to +6V
I _{LED} , AD0, AD1.....	-0.3V to (VDD + 0.3V)
PHI, GSC, PWM, FBO1, FBO2, FBO3, FBI1, FBI2, FBI3.....	-0.3V to (VIN + 0.3V)
STR0 thru STR15	-0.3V to +40V
CGND.....	-0.3V to +0.3V

Current (Into Pin)

VIN.....	50mA
EP.....	-1700mA
STR0 thru STR15	105mA
All other pins.....	20mA

Continuous Power Dissipation

40-pin 6mm x 6mm QFN (derate 37mW/°C above T _A = +70°C)	2963mW
--	--------

Ambient Operating Temperature Range T_A = T_{MIN} to T_{MAX} -40°C to +85°C

Junction Temperature +125°C

Storage Temperature Range..... -65°C to +125°C

Lead Soldering Temperature, 10s +300°C



Electrical Characteristics

Typical application circuit, $V_{IN} = 5V$, $T_A = T_{MIN}$ to T_{MAX} , unless otherwise noted. Typical values are at $V_{IN} = 5V$, $T_A = +25^\circ C$.

PARAMETER	SYMBOL	CONDITIONS AND NOTES	MIN	TYP	MAX	UNIT
DC ELECTRICAL CHARACTERISTICS						
VIN operating supply voltage	VIN		4.75	5	5.5	V
VIN operating supply current	I _{VIN}	EN = VIN, SLEEP = 0, R _{ILED} = 12.7kΩ, PHI = 240Hz, GSC = 983.04kHz, POWERCTRL = 0x4F, ISTR = 0xFF, OSCCTRL = 0x04, GSCINTEN = 0, PHIINTEN = 0, STRnEN = 1	PWMn = 0x7FF	18	21	mA
			PWMn = 0xFFF	24	27.5	
VIN shutdown supply current	I _{SHDN}	EN = GND, SDA, SCL, AD0, AD1, PWM, PHI and GSC = GND		10		μA
VIN sleep current	I _{SLEEP}	EN = 1, SLEEP = 1, SDA, SCL, AD0, AD1, PWM, PHI and GSC = GND or VDD		1.5		mA
VDD regulation voltage	VDD		2.4	2.5	2.6	V
Input high voltage: SDA, SCL, PWM, PHI, GSC, MOSI, CSB, SCK	V _{IH}		0.7 x VDD			V
Input low voltage: SDA, SCL, PWM, PHI, GSC, MOSI, CSB, SCK	V _{IL}				0.3 x VDD	V
Input high voltage: EN			1.22			V
Input low voltage: EN					0.8	V
Output high voltage: PHI, GSC, MISO	V _{OH}	I _{SOURCE} = 5mA	VIN – 0.4			V
Output low voltage: PHI, GSC, SDA, MISO, FLTB	V _{OL}	I _{SINK} = 5mA			0.4	V
ILED regulation voltage		R _{ILED} = 12.7kΩ		350		mV
FBI feedback input current			0		365	μA
FBO feedback output current range		V _{FBO} ≤ VIN – 0.5V	0		365	μA
FBO feedback output current step size				1.1		μA
FBI input disable threshold					140	mV
STR0 thru STR15 sink current		R _{ILED} = 12.7kΩ, ISTR = 0xFF, V _{STRn} = 1V	55	60	67	mA
STR0 thru STR15 sink current maximum		R _{ILED} = 7.68kΩ, ISTR = 0xFF (Note 1)		100		mA
STR0 thru STR15 current load regulation		R _{ILED} = 12.7kΩ; ISTR = 0xFF, FLDBKEN = 0, V _{STRn} = 1V to 5V		0.033		%/V
STR0 thru STR15 current matching		R _{ILED} = 12.7kΩ, ISTR = 0x7F, V _{STRn} = 1V	-5		5	%
STR0 thru STR15 minimum headroom	V _{STR}	R _{ILED} = 12.7kΩ; ISTR = 0xFF		0.5		V

Atmel LED Drivers-MSL4163/MSL4164

16-string, White and RGB LED Drivers with Adaptive Power Control, EEPROM, and SPI/I²C/SMBus Serial Interface

PARAMETER	SYMBOL	CONDITIONS AND NOTES	MIN	TYP	MAX	UNIT
STR0 thru STR15 short circuit fault detection threshold	SC _{REF}	SCTHR = 0x00		4.5		V
		SCTHR = 0x01		5.0		
		SCTHR = 0x02		5.5		
		SCTHR = 0x03		6.0		
STR0 thru STR15 current slew rate		Current rising (Note 2)		608		mA/μs
		Current falling (Note 2)		10868		
Thermal shutdown temperature		(Note 2)		135		°C

PARAMETER	SYMBOL	CONDITIONS AND NOTES	MIN	TYP	MAX	UNIT
AC ELECTRICAL CHARACTERISTICS						
OSC frequency	f _{OSC}	OSCCTRL = 0x04	18.15	20.00	21.88	MHz
PHI frequency	f _{PHI}		0.04		10	kHz
PHI lock				4		PHI cycles
GSC frequency	f _{GSC}		0		10	MHz
PWM frequency	f _{PWM}				50	kHz
PWM duty cycle			0		100	%

PARAMETER	SYMBOL	CONDITIONS AND NOTES	MIN	TYP	MAX	UNIT
I²C TIMING CHARACTERISTICS, MSL4163						
SCL clock frequency	1/t _{SCL}	Bus timeout disabled (Note 3)	0		1	MHz
Bus timeout period	t _{timeout}	OSCCTRL = 0x04		30		ms
		f _{OSC} = 16MHz to 23MHz	600,000 / f _{OSC}			s
STOP to START condition bus free time	t _{BUF}		0.5			μs
Repeated START condition hold time	t _{HD:STA}		0.26			μs
Repeated START condition setup time	t _{SU:STA}		0.26			μs
STOP condition set-up time	t _{SU:STOP}		0.26			μs
SDA data hold time	t _{HD:DAT}		0			ns
SDA data valid acknowledge time	t _{VD:ACK}	(Note 4)	0.05		0.45	μs
SDA data valid time	t _{VD:DAT}	(Note 5)	0.05		0.45	μs
SDA data set-up time	t _{SU:DAT}		100			ns
SCL clock low period	t _{LOW}		0.5			μs
SCL clock high period	t _{HIGH}		0.26			μs
SDA, SCL fall time	t _f	(Note 6) (Note 7)			120	ns
SDA, SCL rise time	t _r				120	ns
SDA, SCL input suppression filter period	t _{SP}	(Note 8)		50		ns

PARAMETER	SYMBOL	CONDITIONS AND NOTES	MIN	TYP	MAX	UNIT
SPI TIMING CHARACTERISTICS, MSL4164						
SCK frequency					20	MHz
CSB to rising edge of SCK set-up time	$t_{\text{CSB:SCK(SU)}}$		20			ns
Rising edge of SCK to CSB hold time	$t_{\text{CSB:SCK(HD)}}$		20			ns
MOSI to rising edge of SCK set-up time	$t_{\text{MOSI(SU)}}$		20			ns
Rising edge of SCK to MOSI hold time	$t_{\text{MOSI(HD)}}$		20			ns
MOSI, CSB, SCK signal rise time	$t_{\text{R(SPI)}}$	receiving		5.0		ns
MOSI, CSB, SCK signal fall time	$t_{\text{F(SPI)}}$	receiving		5.0		ns
MISO signal rise time		$C_{\text{load}} = 10\text{pF}$			20	ns
MISO signal fall time		$C_{\text{load}} = 10\text{pF}$			20	ns
CSB falling edge to MISO data valid	$t_{\text{CSB:MISO(DV)}}$				50	ns
CSB rising edge to MISO high impedance	$t_{\text{CSB:MISO(HIZ)}}$				50	ns
SCK falling edge to MISO data valid	t_{VALID}				20	ns

Note 1. Subject to thermal dissipation characteristics of the device

Note 2. Guaranteed by design, and not production tested.

Note 3. Minimum SCL clock frequency is limited by the bus timeout feature, which resets the serial bus interface if either SDA or SCL is held low for t_{timeout} . Disable bus timeout via the power control register 0x02[6].

Note 4. t_{VDACK} = SCL low to SDA (out) low acknowledge time.

Note 5. t_{VDDAT} = minimum SDA output data-valid time following SCL low transition.

Note 6. A master device must internally provide an SDA hold time of at least 300ns to ensure an SCL low state.

Note 7. The maximum SDA and SCL rise times are 300ns. The maximum SDA fall time is 250ns. This allows series protection resistors to be connected between SDA and SCL inputs and the SDA/SCL bus lines without exceeding the maximum allowable rise time.

Note 8. MSL4163/4 include input filters on SDA, SCL, AD0, and AD1 inputs that suppress noise less than 50ns.

Atmel LED Drivers-MSL4163/MSL4164

16-string, White and RGB LED Drivers with Adaptive Power Control, EEPROM, and SPI/I²C/SMBus Serial Interface

Block Diagram

The block diagram for the MSL4163/4 is shown in Figure 4.

Figure 4. Atmel LED Drivers-MSL4163/4 Block Diagram.

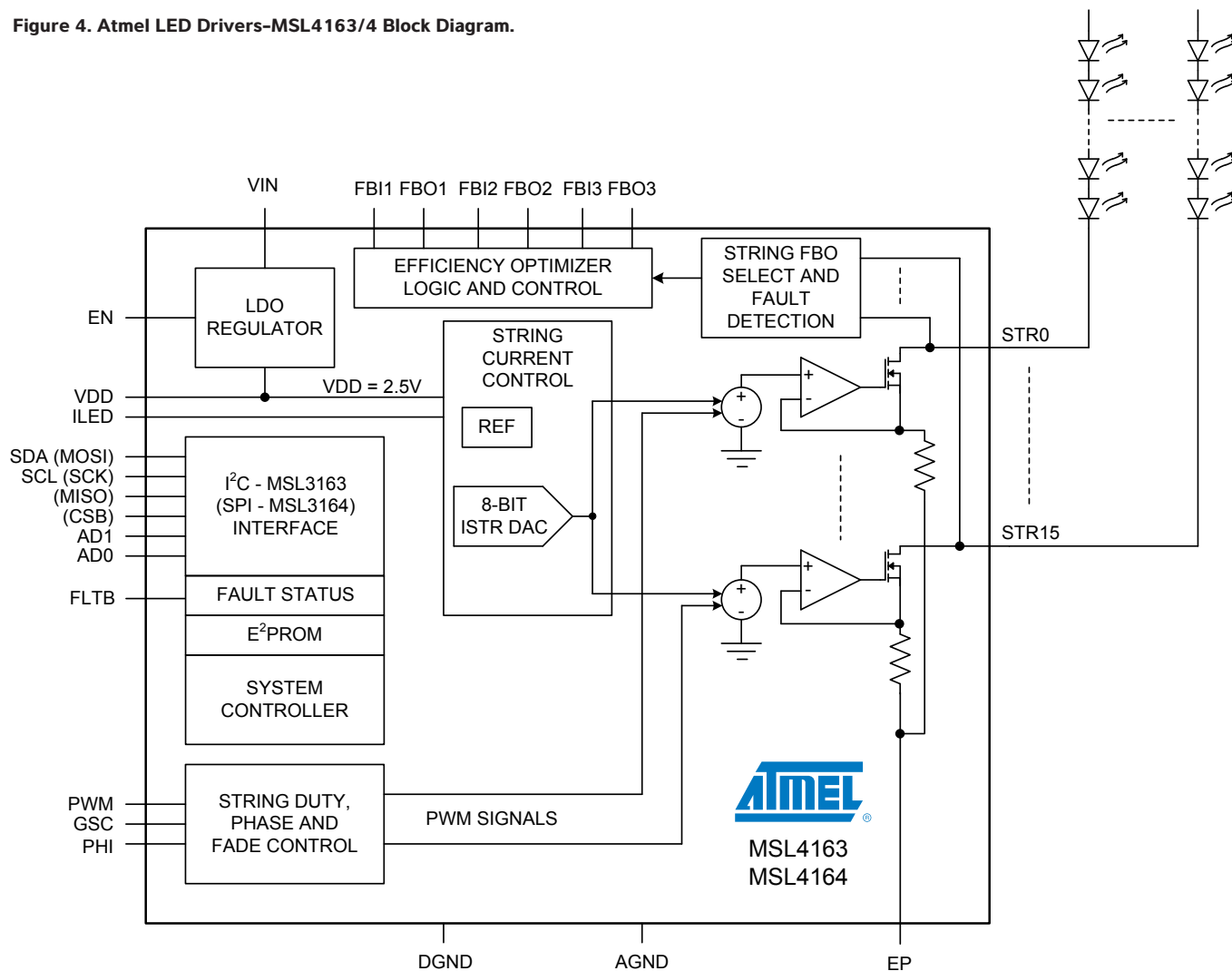

Typical Application Circuit

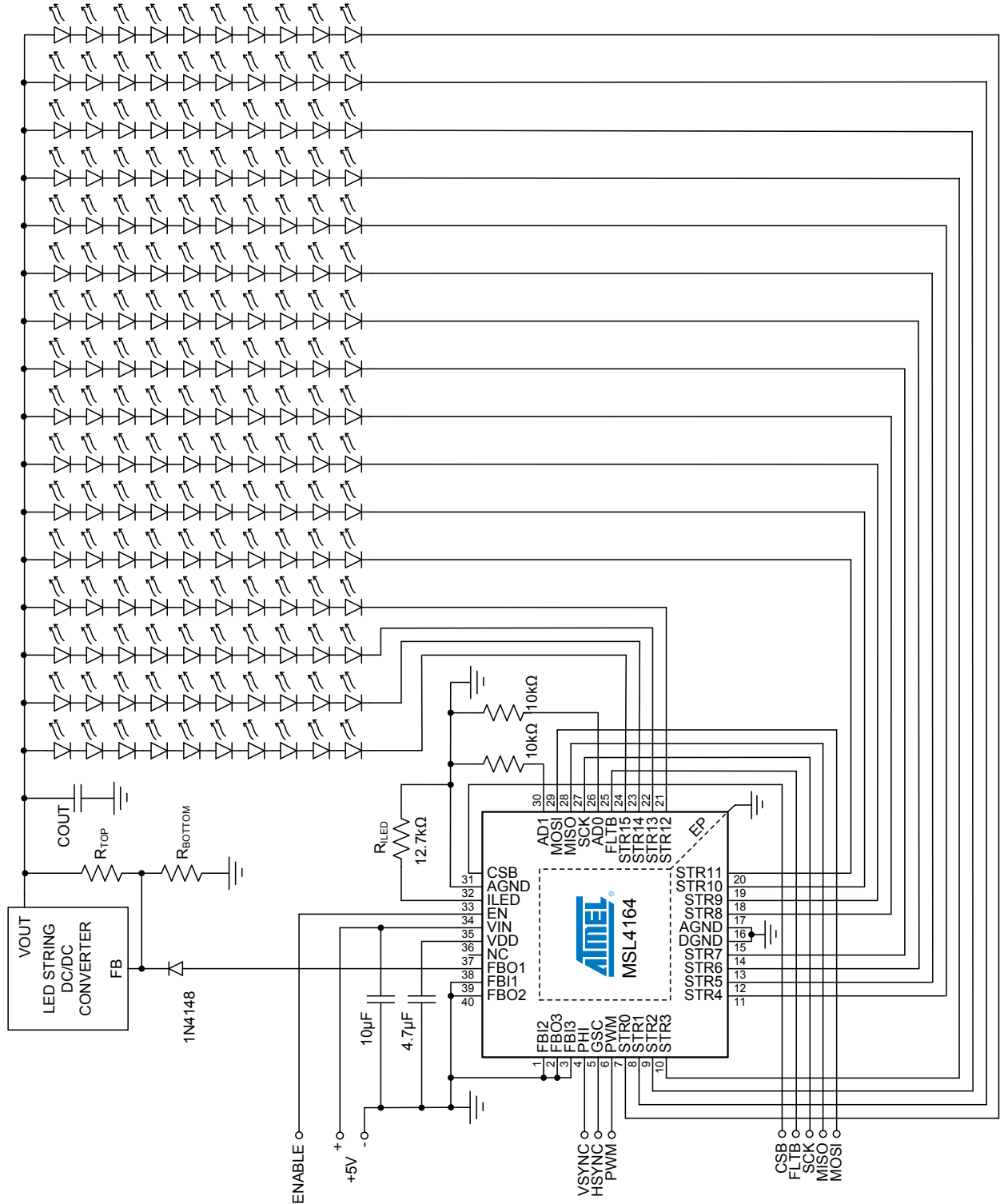

Figure 5. Atmel LED Driver-MSL4164 Driving 160 White LEDs in 16 Strings at 60mA per String.

Atmel LED Drivers-MSL4163/MSL4164

16-string, White and RGB LED Drivers with Adaptive Power Control, EEPROM, and SPI/I²C/SMBus Serial Interface

Detailed Description

The MSL4163 and MSL4164 are highly integrated, flexible multi-string LED drivers with power supply control to maximize system efficiency. The drivers easily connect to a video subsystem. Although optional, this offers a simple architecture for use in LCD TV backlight applications. Up to 16 drivers easily connect together to drive large numbers of LED strings in a system. The drivers provide multiple methods of controlling LED brightness through both peak current control and pulse width control of the string drive signals. Peak current control offers excellent color consistency, while pulse width control allows brightness management. An on-chip EEPROM holds all the default control register values. At power-up, the data in the EEPROM are automatically copied directly to the control registers, setting up the device for operation.

The devices interface to an MCU via I²C (MSL4163) or SPI (MSL4164). The robust, 1MHz I²C interface supports up to 16 devices on the bus. The 20MHz bus addressable SPI bus supports up to 16 devices per chip select line. While typically the LED drive PWM signal is internally generated, both drivers also accept an external, direct-drive PWM signal and offer optional string drive phase spreading. With direct-drive PWM, a pulse width modulated signal applied to the PWM input sets the PWM duty cycle and the frequency of the LED drive signal. With phase spreading enabled, a progressive 1/16 PWM-frame time delay per string helps reduce both the transient load on the LED power supplies and the power supply input capacitor size requirements.

The PWM frequency of the drivers is either synchronized to an external signal applied to PHI or generated from the internal oscillator for standalone applications. Typically, the VSYNC signal from the video system is used for the PHI input. The on time of each string is individually programmed via the device registers, providing a peak resolution of 12 bits when using the on-chip PWM generator. The actual resolution of the PWM frequency depends on the ratio of the

GSC frequency (typically provided by a system's HSYNC signal, but can be internally generated) to the PHI frequency, because the on time of a string is programmed as a 12-bit count of the number of GSC clock cycles. This count can be further scaled by an 8-bit global intensity value, when enabled. The GSC clock is also used to precisely set each string's phase delay so that it is synchronized relative to the video frame.

The efficiency optimizers control a wide range of external DC-DC and AC-DC converter architectures. Multiple drivers in a system communicate with each other in real time to select an optimized operating voltage for the LEDs. This allows design of the power supply for the worst case forward voltage (V_f) of the LEDs without concern about excessive power dissipation issues. During the start-up sequence, the MSL4163/4 automatically reduce the power supply voltage to the minimum voltage required to keep the LEDs in current regulation. The devices can be configured to periodically perform this optimization to compensate for changes in the LED forward voltage, and to assure continued optimum power savings.

Internal Regulators and Enable Input

The MSL4163/4 includes an internal linear regulator that operates from the 5V nominal input supply, VIN, and provides an internal 2.5V supply, VDD, to power the low-voltage internal circuitry. Bypass VDD (pin 36) to GND with a 4.7μF capacitor. Bypass VIN (pin 35) to GND with a 10μF capacitor.

The MSL4163/4 enable input, EN, enables the device. Drive EN low to enter low power operation, which lowers quiescent current draw to less than 20μA. With EN low, the serial interface is ignored. Drive EN high to turn on the device. When EN is driven high, the contents of the EEPROM are boot loaded into the control registers, simulating a cold start-up.



Setting the LED String Current with R_{ILED} and ISTR

The MSL4163/4 features 16 current sink outputs rated at 40V, each designed to sink up to 100mA peak. Limit average current to 60mA if the PCB copper around the MSL4163/4 is the only heat sink employed. The maximum string current, I_{ILED} , for all 16 LED string inputs is set by a single external resistor, R_{ILED} , placed from ILED to GND, whose value is determined using:

$$R_{ILED} = \frac{762}{I_{ILED}}$$

For example, a full-scale LED current of 60mA returns $R_{ILED} = 12.7k\Omega$. The current for all LED strings is reduced from its full-scale value with 8-bit resolution using ISTR, the string current control register, 0x0F.

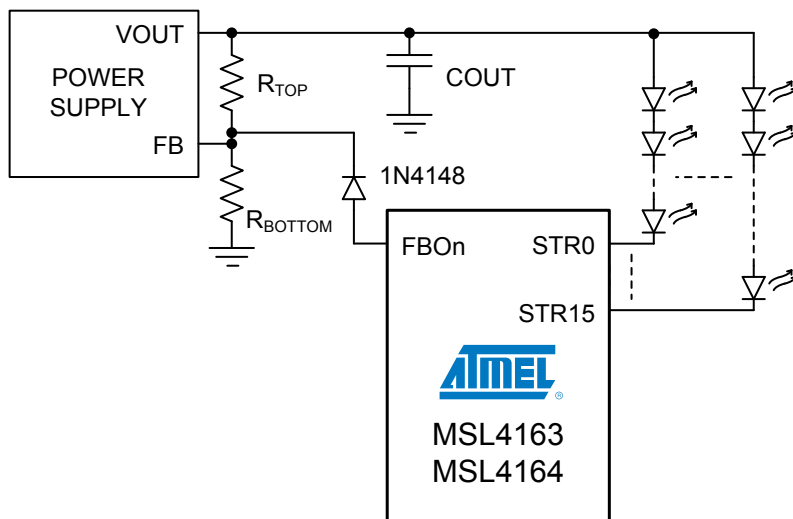

Figure 6. FBO_n Connects to the Power Supply Voltage Divider through a Diode.

Connecting the Efficiency Optimizer to an LED String Power Supply and Selecting Resistors

The MSL4163/4 are designed to control LED string power supplies that use a voltage divider (R_{TOP} and R_{BOTTOM} in Figure 6) to set output voltage, and whose regulation feedback voltage is not more than 3.5V. The efficiency optimizer improves power efficiency by injecting a current of between 0 and 255 μ A into the voltage divider of the external power supply, dynamically adjusting the power supply's output to the minimum voltage required by the LED strings. To select the resistors, first determine $V_{OUT(MIN)}$ and $V_{OUT(MAX)}$, the minimum and maximum string supply voltage limits, using:

$$V_{OUT(MIN)} = (V_{f(MIN)} * [\#ofLEDs]) + 0.5, \text{ and}$$

$$V_{OUT(MAX)} = (V_{f(MAX)} * [\#ofLEDs]) + 0.5,$$

Atmel LED Drivers-MSL4163/MSL4164

16-string, White and RGB LED Drivers with Adaptive Power Control, EEPROM, and SPI/I²C/SMBus Serial Interface

where $V_{f(MIN)}$ and $V_{f(MAX)}$ are the LEDs' minimum and maximum forward voltage drops at the peak current set by R_{ILED} (page 10). For example, if the LED data are $V_{f(MIN)} = 3.5V$ and $V_{f(MAX)} = 3.8V$, and 10 LEDs are used in a string, then the total minimum and maximum voltage drops across the LEDs are 35V and 38V, respectively. Adding an allowance of 0.5V to the string drive MOSFET headroom brings $V_{OUT(MIN)}$ to 35.5V and $V_{OUT(MAX)}$ to 38.5V. Do not to exceed the 40V maximum specification of string drivers STR1 - STR15. Then, determine R_{TOP} using:

$$R_{TOP} = \frac{V_{OUT(MAX)} - V_{OUT(MIN)}}{I_{FBO n(MAX)}}$$

where $I_{FBO n(MAX)}$ is the 255 μ A maximum output current of the efficiency optimizer outputs, FBO_n (if cascading multiple MSL4163/4s determine $I_{FBO n(MAX)}$ as shown in the next section). Finally, determine R_{BOTTOM} using:

$$R_{BOTTOM} = R_{TOP} * \frac{V_{FB}}{V_{OUT(MAX)} - V_{FB}}$$

where V_{FB} is the regulation feedback voltage of the power supply. Place a diode (1N4148 or similar) between FBO_n and the supply's feedback node to protect the MSL4163/4 against current flow into FBO_n.

Using Multiple Atmel LED Drivers-MSL4163/4s to Control a Common Power Supply

Cascade multiple MSL4163/4 devices into a chain configuration, with the FBIn of one device connected to the FBO_n of the next (Figure 7). Connect the first FBO_n to the power supply feedback resistor node through a diode and the unused FBIn inputs (and any unused FBO_n outputs) to GND as close to the MSL4163/4 as possible. Assign all strings powered by a common supply to the proper FBO_n output using string set registers (STRnSET) 0x20 - 0x3F. The chained devices work together to ensure that the system operates at optimum efficiency. Note that the accuracy of the feedback chain may degrade through each link of the FBIn/FBO_n chain by as much as 2%. Determine the potential worst case maximum FBO_n current $I_{FBO n(MAX/MIN)}$ using:

$$I_{FBO n(MAX/MIN)} = 225 A * (0.98)^{N-1}$$

where N is the number of MSL4163/4s connected in series. Use this result in the above R_{TOP} resistor equation for the term $I_{FBO n(MAX)}$ instead of using 255 μ A.

Take care in laying out the traces for the efficiency optimizer connections. Minimize the FBIn/FBO_n trace lengths as much as possible. Do not route the signals close to traces with large variations in voltage or current, because noise may couple into FBIn. If these traces must be routed near noisy signals, shield them from noise by using ground planes or guard traces.

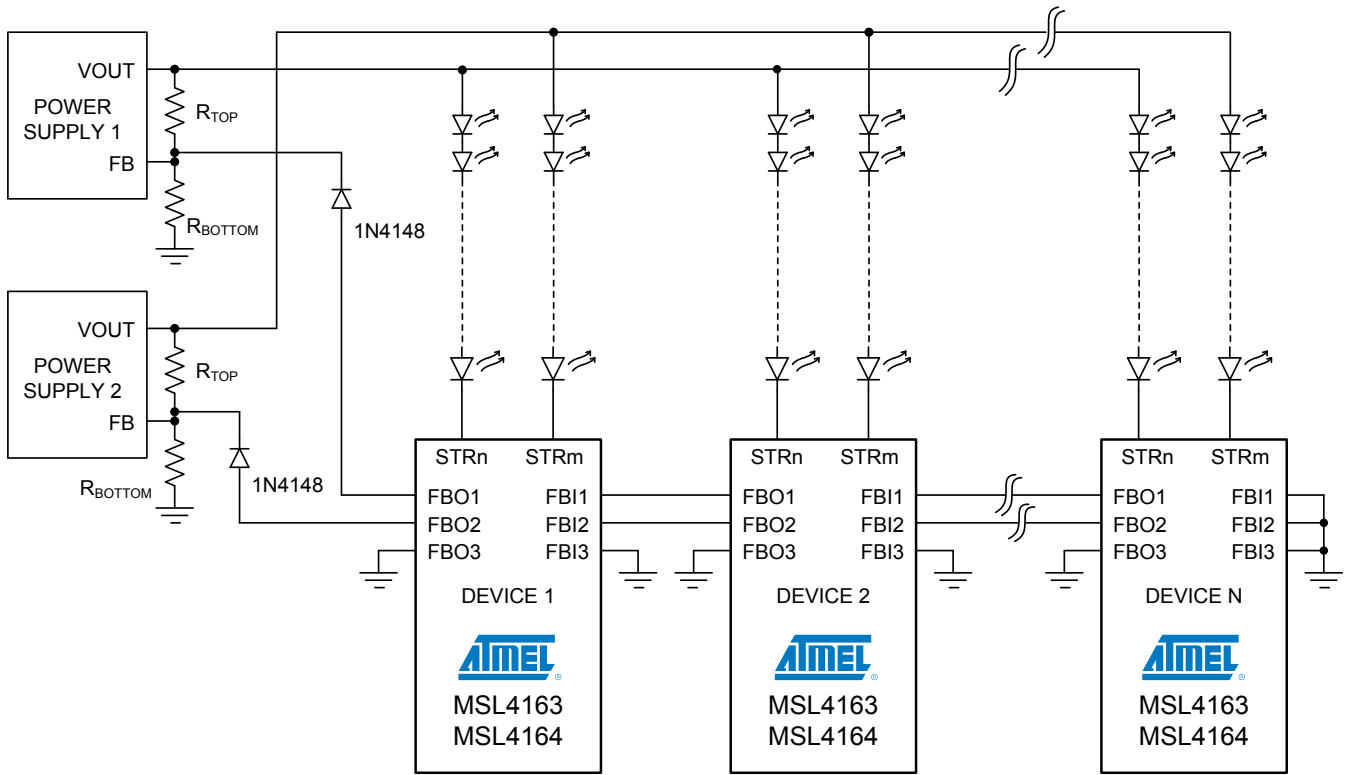

Figure 7. Example of Cascading Multiple Devices to Optimize Common Power Supplies.

Direct PWM Control of the LED Strings

An external PWM signal applied to the PWM input allows direct PWM control over the strings when bits PWMEN and PWMDIRECT are set in PWM control register, 0x1E. This configuration bypasses PHI and GSC, but allows automatic LED string phase delay using bit D2 of register 0x1E.

The PWM input can also be configured as a gate for the output of the PWM engine using the PWM global enable bit D3 of the PWM control register, 0x1E.

Atmel LED Drivers-MSL4163/MSL4164

16-string, White and RGB LED Drivers with Adaptive Power Control, EEPROM, and SPI/I²C/SMBus Serial Interface

Register Map and the EEPROM

Register Map Summary

The MSL4163/4 controlled using the 96 registers in the range 0x00 - 0x5F (Table 2). It may be convenient, and it is allowed, to read and write to unused bits in this range when accessing registers, but always write zeros. Reads from unused bits always return zeros. Three additional registers, 0x90, 0x91, and 0x93, allow access to the EEPROM and provide efficiency optimizer status. The power-up default values for all control registers are stored within the on-chip EEPROM, and any of these EEPROM values may be changed through the serial interface.

Table 2. Atmel LED Drivers-MSL4163/4 Register Map

ADDRESS AND REGISTER NAME		FUNCTION	REGISTER DATA							
			D7	D6	D5	D4	D3	D2	D1	D0
0x00	CONTROL0	LED string enables	STR7EN	STR6EN	STR5EN	STR4EN	STR3EN	STR2EN	STR1EN	STR0EN
0x01	CONTROL1		STR15EN	STR14EN	STR13EN	STR12EN	STR11EN	STR10EN	STR9EN	STR8EN
0x02	POWERCTRL	Fault configuration	SLEEP	I ² CTOEN	PHIMINFEN	GSCMAXFEN	STRSCFEN	STROCFEN	FBOOCEN	FBOEN
0x03	FLTSTATUS	Fault status, global	-	-	PHIMINFLT	GSCMAXFLT	STRSCDET	STROCDDET	FBOOC	FLTDET
0x04	OCSTAT0	String open circuit fault status	OC7	OC6	OC5	OC4	OC3	OC2	OC1	OC0
0x05	OCSTAT1		OC15	OC14	OC13	OC12	OC11	OC10	OC9	OC8
0x06	SCSTAT0	String short circuit fault status	SC7	SC6	SC5	SC4	SC3	SC2	SC1	SC0
0x07	SCSTAT1		SC15	SC14	SC13	SC12	SC11	SC10	SC9	SC8
0x08	FLTMASK0	String fault masks	FLTEN7	FLTEN6	FLTEN5	FLTEN4	FLTEN3	FLTEN2	FLTEN1	FLTEN0
0x09	FLTMASK1		FLTEN15	FLTEN14	FLTEN13	FLTEN12	FLTEN11	FLTEN10	FLTEN9	FLTEN8
0x0A	FBOCTRL0	Efficiency optimizer control	HDRMSTEP[1:0]		FBCLDLY[1:0]		FBSLDLY[1:0]		FBCFDLY[1:0]	
0x0B	FBOCTRL1		SCCDLY[1:0]	DECRSTEP[1:0]		INITPWM	ACAL100	ACALEN	ICCHKDIS	
0x0C	FBODAC1	Efficiency optimizer DAC readback	FBODAC1[7:0]							
0x0D	FBODAC2		FBODAC2[7:0]							
0x0E	FBODAC3		FBODAC3[7:0]							
0x0F	ISTR	8-bit global string current	ISTR[7:0]							
0x10	OSCCTRL	Oscillator frequency	-	-	-	-	-	OSCCTRL[2:0]		
0x11	GSCCTRL	GSC processing control	GSCCHK-SEL	-	-	-	GSCMAXEN	GSCPOL	GSCPHI-SYNCEN	GSCINTEN
0x12	GSCGEN	Internal GSC clock generator	GSCGEN[7:0]							
0x13			GSCGEN[15:8]							
0x14	GSCMUL	GSC multiplier	-	-	-	GSCMUL[4:0]				
0x15	GSCDIV	GSC divider	-	-	-	-	GSCDIV[3:0]			
0x16	GSCMAX	Max oscillator cycles between GSC pulses	GSCMAX[7:0]							
0x17			GSCMAX[15:8]							



Table 2. Atmel LED Drivers-MSL4163/4 Register Map

ADDRESS AND REGISTER NAME		FUNCTION	REGISTER DATA							
			D7	D6	D5	D4	D3	D2	D1	D0
0x18	PHICTRL	PHI processing control	-	-	-	-	-	PHIMINEN	PHIPOL	PHIINTEN
0x19	PHIGEN	Internal PHI clock generator	PHIGEN[7:0]							
0x1A			PHIGEN[15:8]							
0x1B		UNUSED	UNUSED							
0x1C	PHIMIN	Min GSC pulses over PHI period	PHIMIN[7:0]							
0x1D			PHIMIN[11:8]							
0x1E	PWMCTRL	PWM control	FLDBKEN	-	GINTEN	PWM-OFLOWEN	PWMGLBLEN	PHADLYEN	PWM-DIRECT	PWMEN
0x1F	GINT	Global PWM scaling	GINT[7:0]							
0x20	STR0SET	Phase delay and EO assignment for string 0	PHDLY0[7:0]							
0x21			COLSTR0[1:0]	-	-	PHDLY[11:8]				
↓	↓	↓	↓							
0x3E	STR15SET	Phase delay and EO assignment for string 15	PHDLY15[7:0]							
0x3F			COLSTR15[1:0]	-	-	PHDLY[11:8]				
0x40	PWM0	12-bit PWM setting for string 0	PWM0[7:0]							
0x41			-	-	-	-	PWM0[11:8]			
↓	↓	↓	↓							
0x5E	PWM15	12-bit PWM setting for string 15	PWM15[7:0]							
0x5F			-	-	-	-	PWM15[11:8]			
- DO NOT ACCESS ADDRESS RANGE 0X60 THRU 0X73 -										
0x74	SCTHRESH	Short circuit threshold	-	-	-	-	-	-	SCTHR[0:1]	
- DO NOT ACCESS ADDRESS RANGE 0X75 THRU 0X8F -										
0x90	E2ADDR	EEPROM read/write access	E2ADDR[6:0]							
0x91	E2CTRLSTA		E2BUSY	BLDACT	E2ERR	-	-	RWCTRL[2:0]		
0x93	FBOSTATUS	FBO status	FBOOPEN[3:1]			FBOACTIVE[3:1]			FBOCAL	FBOINITCAL

Atmel LED Drivers-MSL4163/MSL4164

16-string, White and RGB LED Drivers with Adaptive Power Control, EEPROM, and SPI/I²C/SMBus Serial Interface

Register Power-Up Defaults

Register power-up default values are shown in Table 3.

Table 3. Atmel LED Drivers-MSL4163/4 Register Power-up Defaults

REGISTER NAME AND ADDRESS		POWER-UP CONDITION	REGISTER DATA							
			D7	D6	D5	D4	D3	D2	D1	D0
0x00	CONTROL0	LED strings STR0 thru STR7 enabled	1	1	1	1	1	1	1	1
0x01	CONTROL1	LED Strings STR8 thru STR15 Enabled	1	1	1	1	1	1	1	1
0x02	POWERCTRL	Efficiency optimizer outputs enabled FBO open circuit detection enabled String open circuit detection enabled LED short circuit detection enabled GSC maximum fault detection disabled PHI minimum fault detection disabled I ² C bus timeout detection enabled Device awake	0	1	0	0	1	1	1	1
0x08	FLTMASK0	Fault detection enabled on all strings	1	1	1	1	1	1	1	1
0x09	FLTMASK1		1	1	1	1	1	1	1	1
0x0A	FBOCTRL0	Current sink error confirmation delay = 4μS FBO power supply correction delay = 2ms Efficiency optimizer recalibration delay = 1s Efficiency optimizer correction steps = 6	0	0	0	0	0	0	0	0
0x0B	FBOCTRL1	Current sink error detection not disabled auto recalibration enabled PWM settings used during auto recalibration PWM duty cycle = 100% during initial calibration Efficiency optimizer operates using 1μA steps LED short circuit confirmation delay = 4μs	0	0	0	1	0	0	1	0
0x0F	ISTR	Strings current set to 50% of R _{ILED} setting	0	1	1	1	1	1	1	1
0x10	OSCCTRL	f _{OSC} = 20MHz	0	0	0	0	0	1	0	0
0x11	GSCCTRL	GSC synchronized to the falling edge of the external signal	0	0	0	0	0	0	0	0
0x12	GSCGEN	Although disabled, internal GSC frequency = 20MHz / (19 + 1) = 1MHz	0	0	0	1	0	0	1	1
0x13			0	0	0	0	0	0	0	0



Table 3. Atmel LED Drivers-MSL4163/4 Register Power-up Defaults

REGISTER NAME AND ADDRESS		POWER-UP CONDITION	REGISTER DATA							
			D7	D6	D5	D4	D3	D2	D1	D0
0x14	GSCMUL	GSC multiplied by 4	0	0	0	0	0	0	1	1
0x15	GSCDIV	GSC not divided	0	0	0	0	0	0	0	0
0x16	GSCMAX	Although disabled, GSC max count is set to 19 clock cycles	0	0	0	1	0	0	1	1
0x17			0	0	0	0	0	0	0	0
0x18	PHICTRL	PHI synchronized to the falling edge of the external signal	0	0	0	0	0	0	0	0
0x19	PHIGEN	Although disabled, internal PHI frequency = $20\text{MHz} / (8 * (10416 + 1)) = 240\text{Hz}$	1	0	1	1	0	0	0	0
0x1A			0	0	1	0	1	0	0	0
0x1C	PHIMIN	No PHI minimum	0	0	0	0	0	0	0	0
0x1D			0	0	0	0	0	0	0	0
0x1E	PWMCTRL	PWM operation enabled Internal PWM engine determines t_{ON} and t_{OFF} Phase delay enabled PWM input not used as gate for PWM engine output String on times allowed to extend beyond PWM frame GINT ignored String current foldback enabled	1	0	0	1	0	1	0	1
0x1F	GINT	Although disabled, global intensity is set to $(127) / 256 = 49.6\%$	0	1	1	1	1	1	1	1
0x20	STROSET	All strings set to zero phase delay Strings efficiency optimizer assignments are: FBO1: Strings 0,4,8,12 FBO2: Strings 1,2,5,6,9,10,13,14 FBO3: Strings 3, 7, 11, 15	0	0	0	0	0	0	0	0
0x21			0*	1*	0	0	0	0	0	0
↓	↓		↓							
0x3E	STR15SET		0	0	0	0	0	0	0	0
0x3F			1*	1*	0	0	0	0	0	0

Atmel LED Drivers-MSL4163/MSL4164

16-string, White and RGB LED Drivers with Adaptive Power Control, EEPROM, and SPI/I²C/SMBus Serial Interface

REGISTER NAME AND ADDRESS		POWER-UP CONDITION	REGISTER DATA							
			D7	D6	D5	D4	D3	D2	D1	D0
0x40	PWM0	All strings have PWM value = 512 GSC cycles	0	0	0	0	0	0	0	0
0x41			0	0	0	0	0	0	1	0
↓	↓		↓							
0x5E	PWM15		0	0	0	0	0	0	0	0
0x5F			0	0	0	0	0	0	1	0
0x74	SCTHRESH		SC _{REF} = 6.0V	0	0	0	0	0	0	1
0x90	E2ADDR	EEPROM 7-bit address = 0x00	0	0	0	0	0	0	0	0
0x91	E2CTRLSTA	EEPROM read/write disabled	0	0	0	0	0	0	0	0
0x93	FBOSTATUS	Feedback output status	0	0	0	0	0	0	0	0

* These bits set the FBO_n string assignments.

**Atmel Corporation**

2325 Orchard Parkway
San Jose, CA 95131
USA

Tel: (+1)(408) 441-0311

Fax: (+1)(408) 487-2600

www.atmel.com

Atmel Asia Limited

Unit 01-5 & 16, 19F
BEA Tower, Millennium City 5
418 Kwun Tong Road
Kwun Tong, Kowloon
HONG KONG

Tel: (+852) 2245-6100

Fax: (+852) 2722-1369

Atmel Munich GmbH

Business Campus
Parking 4
D-85748 Garching b. Munich
GERMANY

Tel: (+49) 89-31970-0

Fax: (+49) 89-3194621

Atmel Japan

9F, Tonetsu Shinkawa Bldg.
1-24-8 Shinkawa
Chuo-ku, Tokyo 104-0033
JAPAN

Tel: (+81)(3) 3523-3551

Fax: (+81)(3) 3523-7581

© 2011 Atmel Corporation. All rights reserved. / Rev.: MEM-MSL4163/64DB1-E-US_06-11

Atmel®, logo and combinations thereof, and others are registered trademarks or trademarks of Atmel Corporation or its subsidiaries. Other terms and product names may be trademarks of others.

Disclaimer: The information in this document is provided in connection with Atmel products. No license, express or implied, by estoppel or otherwise, to any intellectual property right is granted by this document or in connection with the sale of Atmel products. EXCEPT AS SET FORTH IN THE ATMEL TERMS AND CONDITIONS OF SALES LOCATED ON THE ATMEL WEBSITE, ATMEL ASSUMES NO LIABILITY WHATSOEVER AND DISCLAIMS ANY EXPRESS, IMPLIED OR STATUTORY WARRANTY RELATING TO ITS PRODUCTS INCLUDING, BUT NOT LIMITED TO, THE IMPLIED WARRANTY OF MERCHANTABILITY, FITNESS FOR A PARTICULAR PURPOSE, OR NON-INFRINGEMENT. IN NO EVENT SHALL ATMEL BE LIABLE FOR ANY DIRECT, INDIRECT, CONSEQUENTIAL, PUNITIVE, SPECIAL OR INCIDENTAL DAMAGES (INCLUDING, WITHOUT LIMITATION, DAMAGES FOR LOSS AND PROFITS, BUSINESS INTERRUPTION, OR LOSS OF INFORMATION) ARISING OUT OF THE USE OR INABILITY TO USE THIS DOCUMENT, EVEN IF ATMEL HAS BEEN ADVISED OF THE POSSIBILITY OF SUCH DAMAGES. Atmel makes no representations or warranties with respect to the accuracy or completeness of the contents of this document and reserves the right to make changes to specifications and products descriptions at any time without notice. Atmel does not make any commitment to update the information contained herein. Unless specifically provided otherwise, Atmel products are not suitable for, and shall not be used in, automotive applications. Atmel products are not intended, authorized, or warranted for use as components in applications intended to support or sustain life.