



ON Semiconductor®

<http://onsemi.com>

# LV8772

Bi-CMOS LSI

## PWM Constant-Current Control Stepping Motor Driver

### Overview

The LV8772 is a stepping motor driver, which is capable of micro-step drive and supports 4W 1-2 phase excitation. It is stepping motors used in office equipment and amusement applications.

### Features

- Low on resistance (upper side : 0.3Ω ; lower side : 0.25Ω ; total of upper and lower : 0.55Ω ; Ta = 25°C, IO = 2.5A)
- Excitation mode can be set to 2-phase, 1-2 phase, W1-2 phase , or 4W1-2 phase
- BiCDMOS process IC
- Motor current selectable in four steps
- Unusual condition warning output pins
- Excitation step proceeds only by step signal input
- Output short-circuit protection circuit incorporated
- No control power supply required

### Specifications

**Absolute Maximum Ratings** at Ta = 25°C

Parameter	Symbol	Conditions	Ratings	Unit
Supply voltage	VM max		36	V
Output peak current	IO peak	tw ≤ 10ms, duty 20%	3.0	A
Output current	IO max		2.5	A
Logic input voltage	VIN		-0.3 to +6	V
MONI/EMO input voltage	Vmoni/Vemo		-0.3 to +6	V
Allowable power dissipation	Pd max1	1 unit	3.0	W
	Pd max2	*	5.4	W
Operating temperature	Topr		-20 to +85	°C
Storage temperature	Tstg		-55 to +150	°C

\* Specified circuit board : 90.0mm×90.0mm×1.6mm, glass epoxy 2-layer board, with backside mounting.

Caution 1) Absolute maximum ratings represent the value which cannot be exceeded for any length of time.

Caution 2) Even when the device is used within the range of absolute maximum ratings, as a result of continuous usage under high temperature, high current, high voltage, or drastic temperature change, the reliability of the IC may be degraded. Please contact us for the further details.

Stresses exceeding Maximum Ratings may damage the device. Maximum Ratings are stress ratings only. Functional operation above the Recommended Operating Conditions is not implied. Extended exposure to stresses above the Recommended Operating Conditions may affect device reliability.

# LV8772

## Allowable Operating Ratings at Ta = 25°C

Parameter	Symbol	Conditions	Ratings	Unit
Supply voltage range	VM		9 to 32	V
Logic input voltage	V <sub>IN</sub>		0 to 5.5	V
VREF input voltage range	VREF		0 to 3	V

## Electrical Characteristics at Ta = 25°C, VM = 24V, VREF = 1.5V

Parameter	Symbol	Conditions	Ratings			Unit	
			min	typ	max		
Standby mode current drain	IMst	ST = "L"		100	400	μA	
Current drain	IM	ST = "H", with no load		3.2	5	mA	
VREG5 output voltage	Vreg5	I <sub>O</sub> = -1mA	4.5	5	5.5	V	
Thermal shutdown temperature	TSD	Design guarantee	150	180	200	°C	
Thermal hysteresis width	ΔTSD	Design guarantee		40		°C	
<b>Motor driver</b>							
Output on resistance	Ronu	I <sub>O</sub> = 2.5A, Upper-side on resistance		0.3	0.4	Ω	
	Rond	I <sub>O</sub> = 2.5A, Lower-side on resistance		0.25	0.33	Ω	
Output leakage current	I <sub>Oleak</sub>				50	μA	
Diode forward voltage	VD	ID = -2.5A		1.2	1.4	V	
Logic pin input current	I <sub>INL</sub>	V <sub>IN</sub> = 0.8V	4	8	12	μA	
	I <sub>INH</sub>	V <sub>IN</sub> = 5V	30	50	70	μA	
Logic high-level input voltage	V <sub>INH</sub>		2.0			V	
Logic low-level input voltage	V <sub>INL</sub>				0.8	V	
Current setting comparator threshold voltage (current step switching)	4W1-2-phase drive	Vtdac0_4W	Step 0 (When initialized : channel 1 comparator level)	0.291	0.3	0.309	V
		Vtdac1_4W	Step 1 (Initial state+1)	0.291	0.3	0.309	V
		Vtdac2_4W	Step 2 (Initial state+2)	0.285	0.294	0.303	V
		Vtdac3_4W	Step 3 (Initial state+3)	0.279	0.288	0.297	V
		Vtdac4_4W	Step 4 (Initial state+4)	0.267	0.276	0.285	V
		Vtdac5_4W	Step 5 (Initial state+5)	0.255	0.264	0.273	V
		Vtdac6_4W	Step 6 (Initial state+6)	0.240	0.249	0.258	V
		Vtdac7_4W	Step 7 (Initial state+7)	0.222	0.231	0.240	V
		Vtdac8_4W	Step 8 (Initial state+8)	0.201	0.210	0.219	V
		Vtdac9_4W	Step 9 (Initial state+9)	0.180	0.189	0.198	V
		Vtdac10_4W	Step 10 (Initial state+10)	0.157	0.165	0.173	V
		Vtdac11_4W	Step 11 (Initial state+11)	0.134	0.141	0.148	V
		Vtdac12_4W	Step 12 (Initial state+12)	0.107	0.114	0.121	V
		Vtdac13_4W	Step 13 (Initial state+13)	0.080	0.087	0.094	V
		Vtdac14_4W	Step 14 (Initial state+14)	0.053	0.060	0.067	V
	Vtdac15_4W	Step 15 (Initial state+15)	0.023	0.030	0.037	V	
	W1-2-phase drive	Vtdac0_W	Step 0 (When initialized : channel 1 comparator level)	0.291	0.3	0.309	V
		Vtdac4_W	Step 4 (Initial state+1)	0.267	0.276	0.285	V
		Vtdac8_W	Step 8 (Initial state+2)	0.201	0.21	0.219	V
		Vtdac12_W	Step 12 (Initial state+3)	0.107	0.114	0.121	V
1-2 phase drive	Vtdac0_H	Step 0 (When initialized : channel 1 comparator level)	0.291	0.3	0.309	V	
	Vtdac8_H	Step 8 (Initial state+1)	0.201	0.21	0.219	V	
2 phase drive	Vtdac8_F	Step 8' (When initialized : channel 1 comparator level)	0.291	0.3	0.309	V	
Current setting comparator threshold voltage (current attenuation rate switching)	Vtatt00	ATT1 = L, ATT2 = L	0.291	0.3	0.309	V	
	Vtatt01	ATT1 = H, ATT2 = L	0.232	0.24	0.248	V	
	Vtatt10	ATT1 = L, ATT2 = H	0.143	0.15	0.157	V	
	Vtatt11	ATT1 = H, ATT2 = H	0.053	0.06	0.067	V	
Chopping frequency	Fchop	Cchop = 180pF	45	55	65	kHz	
CHOP pin charge/discharge current	Ichop		7	10	13	μA	

Continued on next page.

# LV8772

Continued from preceding page.

Parameter	Symbol	Conditions	Ratings			Unit
			min	typ	max	
Chopping oscillation circuit threshold voltage	Vtup		0.8	1	1.2	V
	Vtdown		0.4	0.5	0.6	V
VREF pin input current	Iref	VREF = 1.5V	-0.5			μA
MONI pin saturation voltage	Vsatmon	Imoni = 1mA			400	mV
<b>Charge pump</b>						
VG output voltage	VG		28	28.7	29.8	V
Rise time	tONG	VG = 0.1μF, CP1-CP2 = 0.1μF, ST = "H" → VG = VM+4V		200	500	μS
Oscillator frequency	Fosc		90	125	150	kHz
<b>Output short-circuit protection</b>						
EMO pin saturation voltage	Vsatemo	Iemo = 1mA			400	mV

## Package Dimensions

unit : mm (typ)

3147C

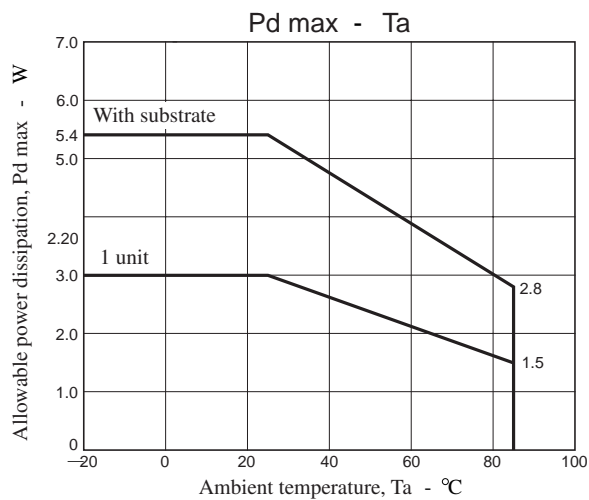
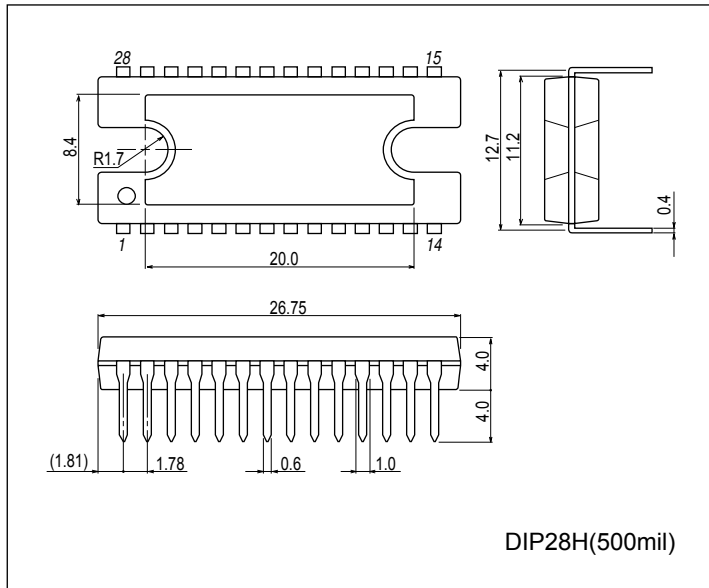

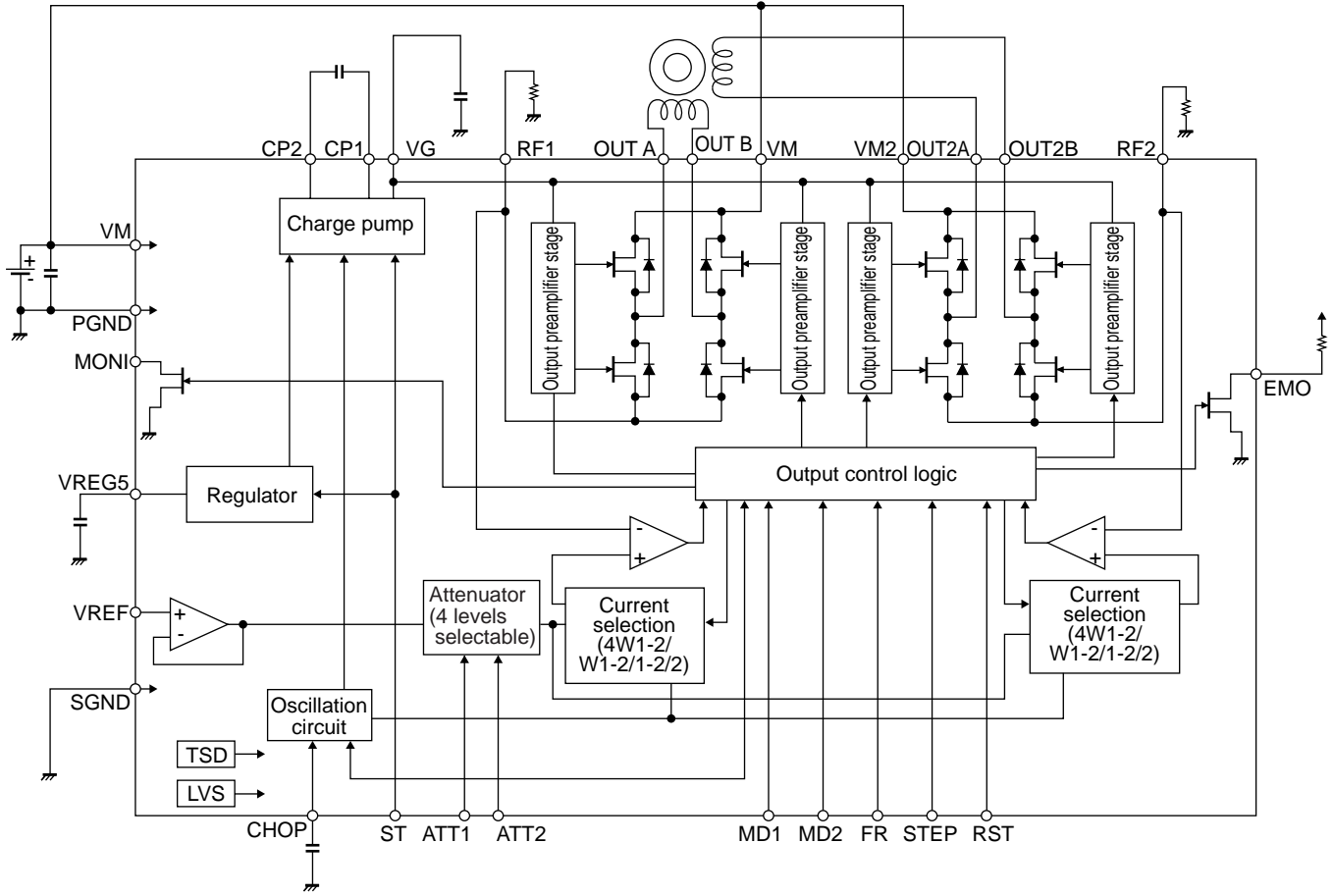

# LV8772

## Pin Assignment

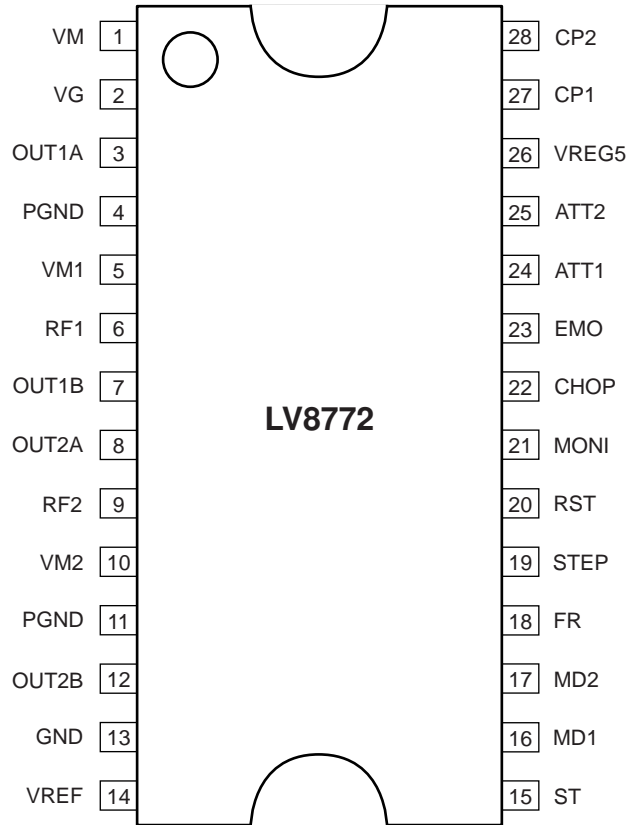

Top view

## Pin Functions

Pin No.	Pin Name	Pin Function	Equivalent Circuit
25 24 20 19 18 17 16	ATT2 ATT1 RST STEP FR MD2 MD1	Motor holding current switching pin. Motor holding current switching pin. RESET input pin STEP signal input pin CW / CCW signal input pin Excitation mode switching pin 2 Excitation mode switching pin 1	
15	ST	Chip enable pin.	

Continued on next page.

# LV8772

Continued from preceding page.

Pin No.	Pin Name	Pin Function	Equivalent Circuit
12 4/11 10 9 8 7 6 5 3	OUT2B PGND VM2 RF2 OUT2A OUT1B RF1 VM1 OUT1A	Channel 2 OUTB output pin. Power system ground. Channel 2 motor power supply connection pin. Channel 2 current-sense resistor connection pin. Channel 2 OUTA output pin. Channel 1 OUTB output pin. Channel 1 current-sense resistor connection pin. Channel 1 motor power supply pin. Channel 1 OUTA output pin	
2 1 28 27	VG VM CP2 CP1	Charge pump capacitor connection pin. Motor power supply connection pin. Charge pump capacitor connection pin. Charge pump capacitor connection pin	
14	VREF	Constant current control reference voltage input pin	
26	VREG5	Internal power supply capacitor connection pin	

Continued on next page.

# LV8772

Continued from preceding page.

Pin No.	Pin Name	Pin Function	Equivalent Circuit
23  21	EMO  MONI	Output short-circuit state warning output pin. Position detection monitor pin.	<p style="text-align: center;">VREG5 ○</p> <p style="text-align: center;">GND ○</p>
22	CHOP	Chopping frequency setting capacitor connection pin	<p style="text-align: center;">VREG5 ○</p> <p style="text-align: center;">GND ○</p> <p style="text-align: center;">500Ω 500Ω</p>

**Description of operation**

**Input Pin Function**



(1) Chip enable function

This IC is switched between standby and operating mode by setting the ST pin. In standby mode, the IC is set to power-save mode and all logic is reset. In addition, the internal regulator circuit and charge pump circuit do not operate in standby mode.

ST	Mode	Internal regulator	Charge pump
Low or Open	Standby mode	Standby	Standby
High	Operating mode	Operating	Operating

**Stepping mode drive method**

(1) STEP pin function

Input		Operating mode
ST	STP	
Low	*	Standby mode
High		Excitation step proceeds
High		Excitation step is kept

(2) Excitation mode setting function

MD1	MD2	Excitation mode	Initial position	
			Channel 1	Channel 2
Low	Low	2 phase excitation	100%	-100%
High	Low	1-2 phase excitation	100%	0%
Low	High	W1-2 phase excitation	100%	0%
High	High	4W1-2 phase excitation	100%	0%

This is the initial position of each excitation mode in the initial state after power-on and when the counter is reset.

(3) Position detection monitoring function

The MONI position detection monitoring pin is of an open drian type. When the excitation position is in the initial position, the MONI output is placed in the ON state. (Refer to "Examples of current waveforms in each of the excitation modes.")

(4) Setting constant-current control reference current

This IC is designed to automatically exercise PWM constant-current chopping control for the motor current by setting the output current. Based on the voltage input to the VREF pin and the resistance connected between RF and GND, the output current that is subject to the constant-current control is set using the calculation formula below :

$$I_{OUT} = (VREF/5)/RF \text{ resistance}$$

\* The above setting is the output current at 100% of each excitation mode.

The voltage input to the VREF pin can be switched to four-step settings depending on the statuses of the two inputs, ATT1 and ATT2. This is effective for reducing power consumption when motor holding current is supplied.

Attenuation function for VREF input voltage

ATT1	ATT2	Current setting reference voltage attenuation ratio
Low	Low	100%
High	Low	80%
Low	High	50%
High	High	20%

The formula used to calculate the output current when using the function for attenuating the VREF input voltage is given below.

$$I_{OUT} = (VREF/5) \times (\text{attenuation ratio})/RF \text{ resistance}$$



Example : At VREF of 1.5V, a reference voltage setting of 100% [(ATT1, ATT2) = (L, L)] and an RF resistance of 0.22Ω, the output current is set as shown below.

$$I_{OUT} = 1.5V/5 \times 100\%/0.22\Omega = 1.36A$$

If, in this state, (ATT1, ATT2) is set to (H, H), IO<sub>UT</sub> will be as follows :

$$I_{OUT} = 1.36A \times 20\% = 272mA$$

In this way, the output current is attenuated when the motor holding current is supplied so that power can be conserved.

(5) Blanking period

If, when exercising PWM constant-current chopping control over the motor current, the mode is switched from decay to charge, the recovery current of the parasitic diode may flow to the current sensing resistance, causing noise to be carried on the current sensing resistance pin, and this may result in erroneous detection. To prevent this erroneous detection, a blanking period is provided to prevent the noise occurring during mode switching from being received. During this period, the mode is not switched from charge to decay even if noise is carried on the current sensing resistance pin.

This IC is the blanking time is fixed at approximately 1μs.

(6) Reset function

RST	Operating mode
Low	Normal operation
High	Reset state

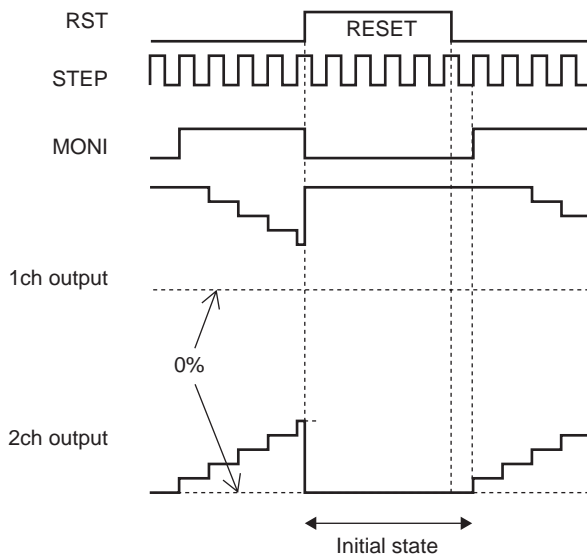

When the RST pin is set to High, the excitation position of the output is forcibly set to the initial state, and the MONI output is placed in the ON state. When RST is then set to Low, the excitation position is advanced by the next STEP input.

(7) Forward/reverse switching function

FR	Operating mode
Low	Clockwise (CW)
High	Counter-clockwise (CCW)

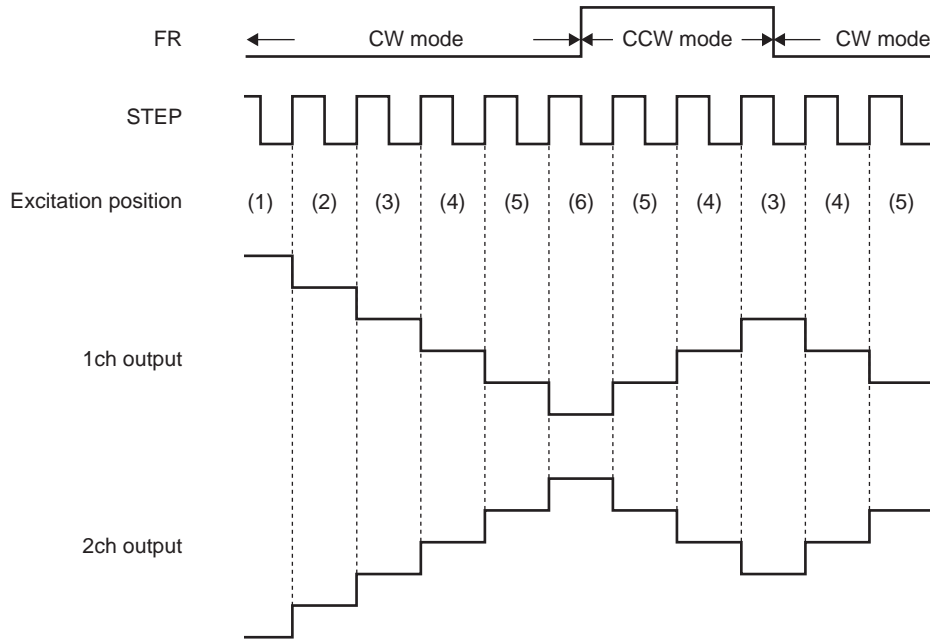

The internal D/A converter proceeds by one bit at the rising edge of the input STEP pulse.  
 In addition, CW and CCW mode are switched by setting the FR pin.  
 In CW mode, the channel 2 current phase is delayed by 90° relative to the channel 1 current.  
 In CCW mode, the channel 2 current phase is advanced by 90° relative to the channel 1 current.

(8) Chopping frequency setting

For constant-current control, this IC performs chopping operations at the frequency determined by the capacitor (Cchop) connected between the CHOP pin and GND.  
 The chopping frequency is set as shown below by the capacitor (Cchop) connected between the CHOP pin and GND.

$$F_{chop} = I_{chop} / (C_{chop} \times V_{tchop} \times 2) \text{ (Hz)}$$

$I_{chop}$  : Capacitor charge/discharge current, typ 10μA

$V_{tchop}$  : Charge/discharge hysteresis voltage ( $V_{tup} - V_{tdown}$ ), typ 0.5V

For instance, when Cchop is 180pF, the chopping frequency will be as follows :

$$F_{chop} = 10\mu A / (180pF \times 0.5V \times 2) = 55kHz$$

# LV8772

(9) Output current vector locus (one step is normalized to 90 degrees)

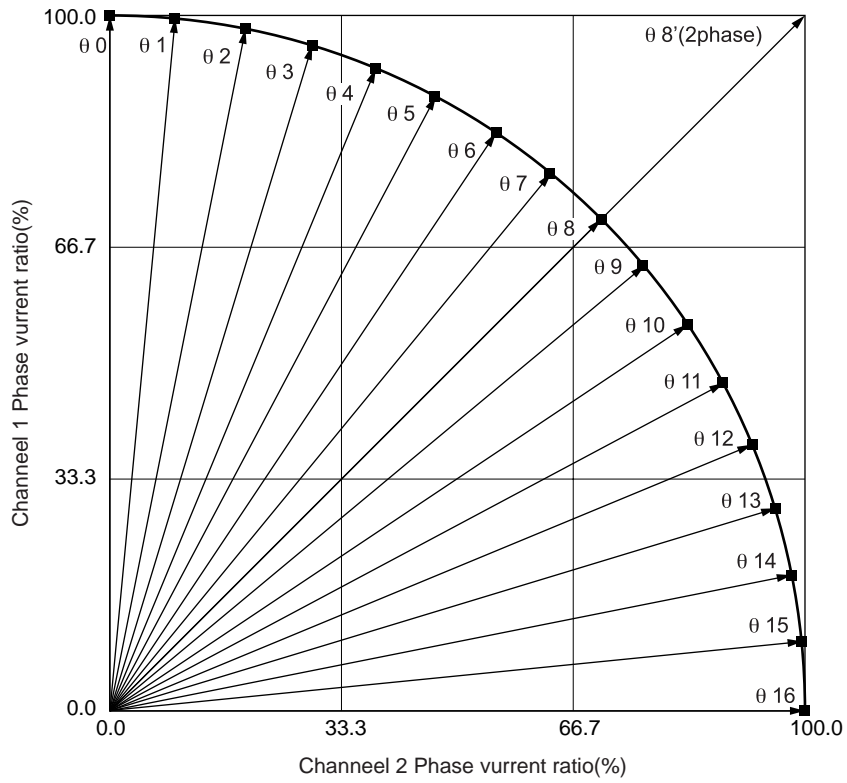

Setting current ration in each excitation mode

STEP	4W1-2 phase (%)		W1-2 phase (%)		1-2 phase (%)		2-phase (%)	
	Channel 1	Channel 2	Channel 1	Channel 2	Channel 1	Channel 2	Channel 1	Channel 2
θ0	100	0	100	0	100	0		
θ1	100	10						
θ2	98	20						
θ3	96	29						
θ4	92	38	92	38				
θ5	88	47						
θ6	83	55						
θ7	77	63						
θ8	70	70	70	70	70	70	100	100
θ9	63	77						
θ10	55	83						
θ11	47	88						
θ12	38	92	38	92				
θ13	29	96						
θ14	20	98						
θ15	10	100						
θ16	0	100	0	100	0	100		

(10) Typical current waveform in each excitation mode

2-phase excitation (CW mode)

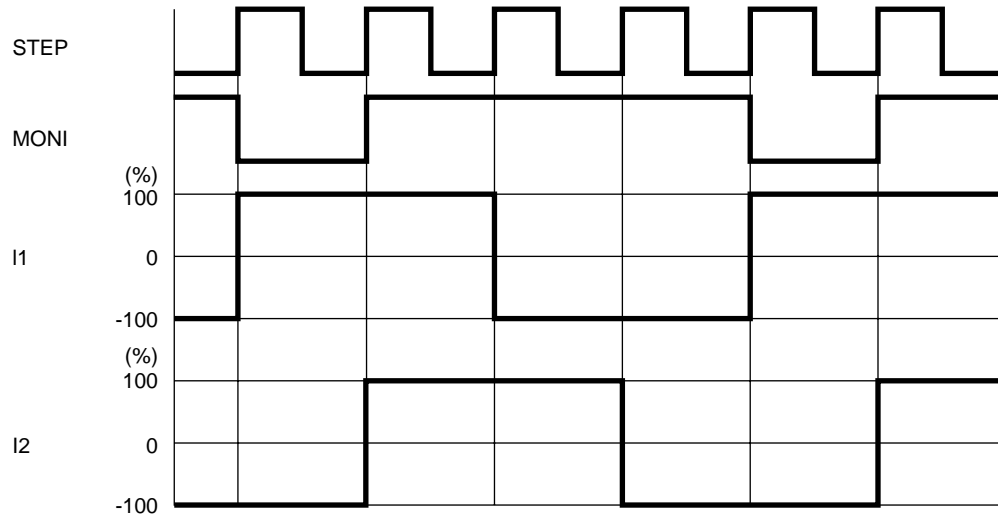

1-2 phase excitation (CW mode)

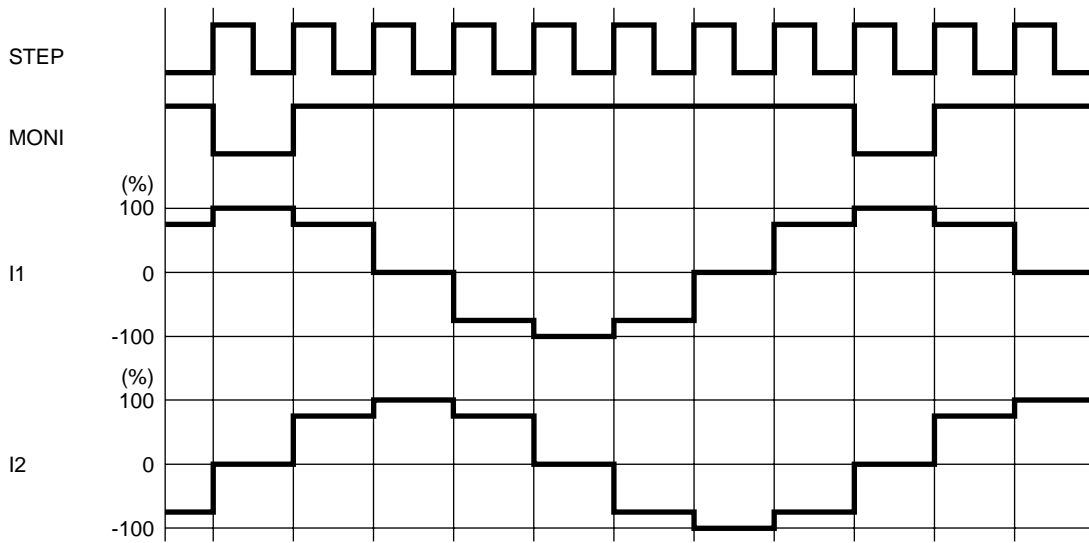

W1-2 phase excitation (CW mode)

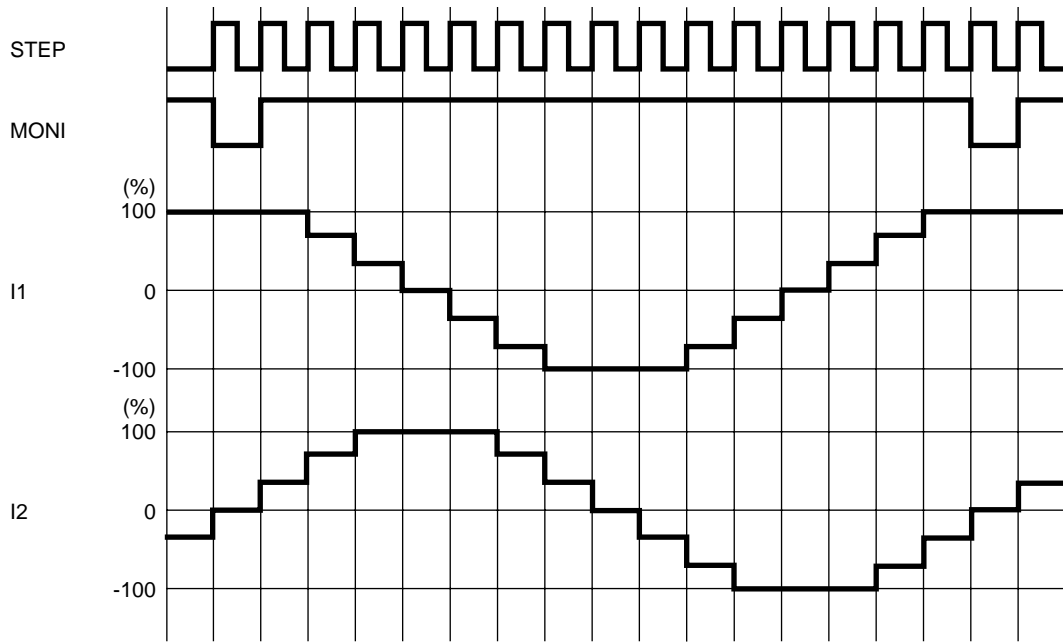

4W1-2 phase excitation (CW mode)

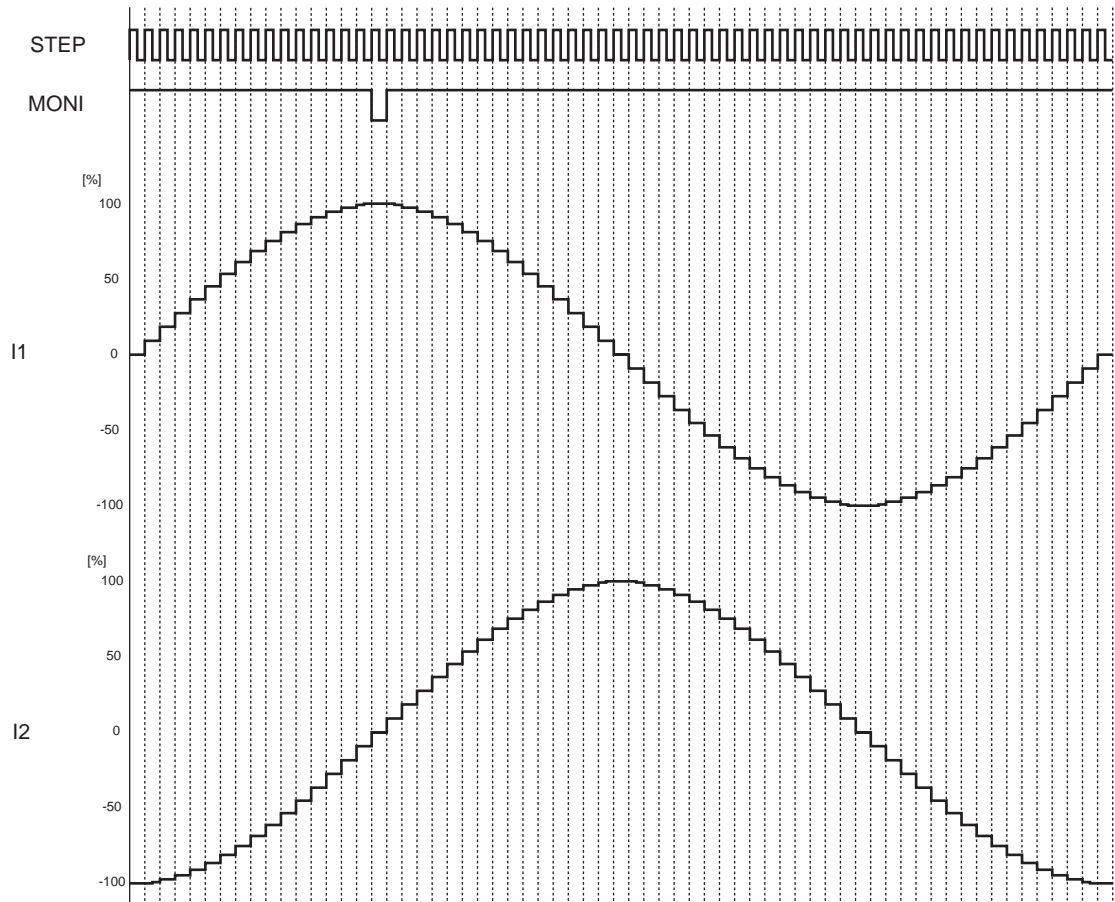

(11) Current control operation specification

(Sine wave increasing direction)

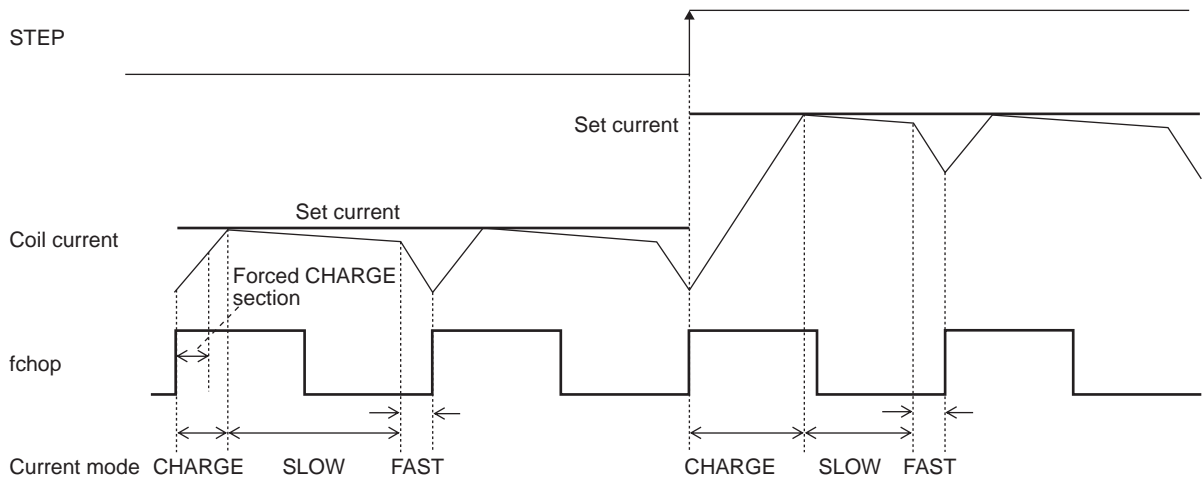

(Sine wave decreasing direction)

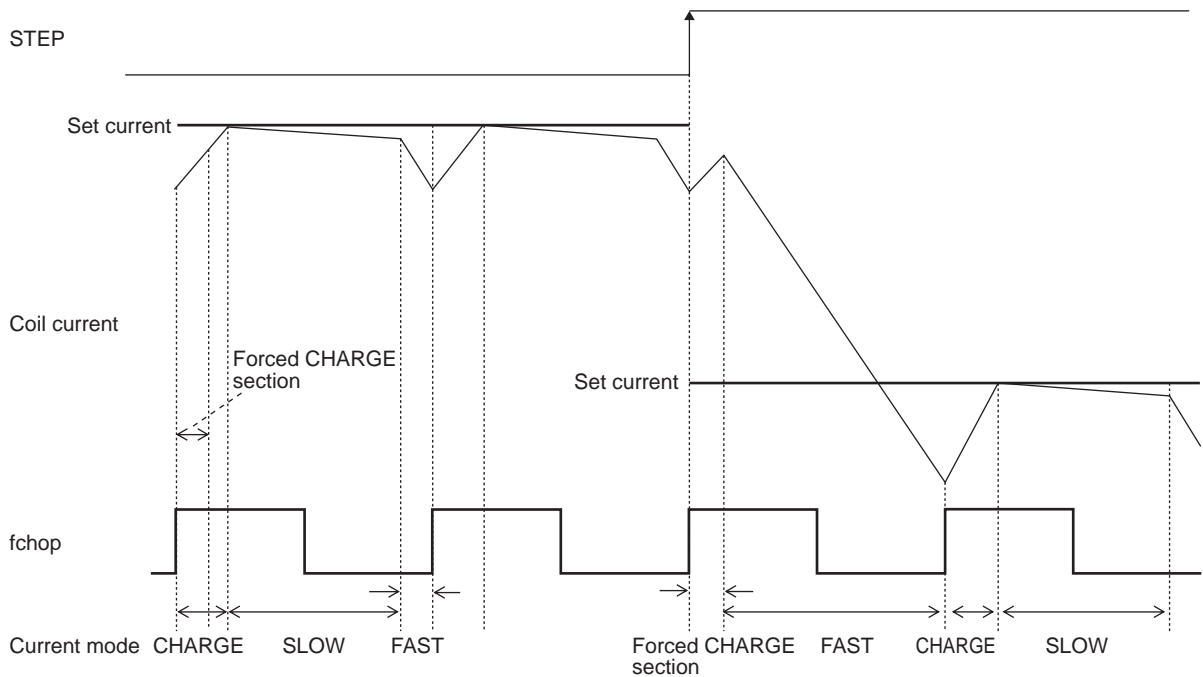

In each current mode, the operation sequence is as described below :

- At rise of chopping frequency, the CHARGE mode begins. (In the time defined as the “blanking time,” the CHARGE mode is forced regardless of the magnitude of the coil current (ICOIL) and set current (IREF).)
- The coil current (ICOIL) and set current (IREF) are compared in this blanking time.

When  $(ICOIL < IREF)$  state exists ;

The CHARGE mode up to  $ICOIL \geq IREF$ , then followed by changeover to the SLOW DECAy mode, and finally by the FAST DECAy mode for approximately  $1\mu s$ .

When  $(ICOIL < IREF)$  state does not exist ;

The FAST DECAy mode begins. The coil current is attenuated in the FAST DECAy mode till one cycle of chopping is over.

Above operations are repeated. Normally, the SLOW (+FAST) DECAy mode continues in the sine wave increasing direction, then entering the FAST DECAy mode till the current is attenuated to the set level and followed by the SLOW DECAy mode.

**Output short-circuit protection function**

This IC incorporates an output short-circuit protection circuit that, when the output has been shorted by an event such as shorting to power or shorting to ground, sets the output to the standby mode and turns on the warning output in order to prevent the IC from being damaged.

This function sets the output to the standby mode for both channels by detecting the short-circuiting in one of the channels.

**(1) Output short-circuit protection method**

The output short-circuit protection method of LV8772 is a latch method to turn off the output when the output current exceeds the detection current, and to maintain the state.

The detection of the output short-circuited state by the IC causes the output short-circuit protection circuit to be activated.

All the outputs of correspondence ch side where the short-circuit was first detected are switched to the standby mode when the short-circuit is the consecutive between internal timers (approximately 4μs), and the state is maintained.

This state is released by setting ST to low.

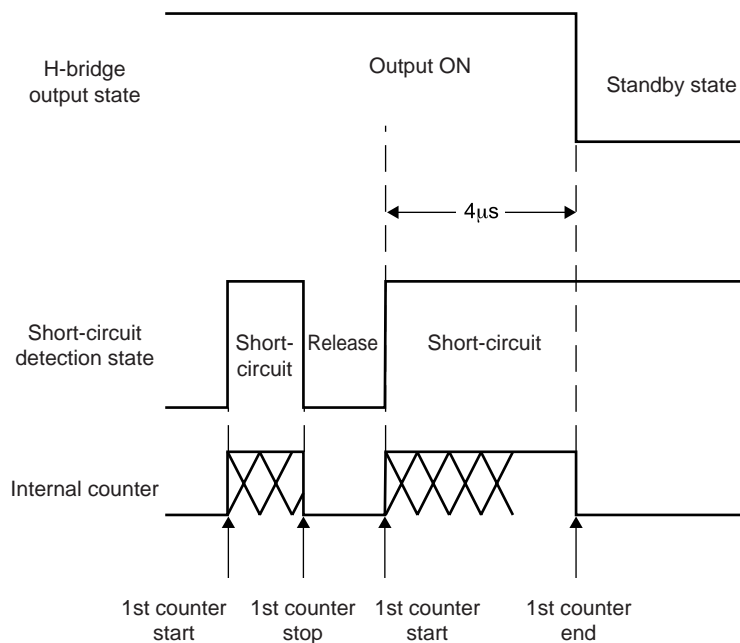

**(2) Unusual condition warning output pins (EMO)**

The LV8772 is provided with the EMO pin which notifies the CPU of an unusual condition if the protection circuit operates by detecting an unusual condition of the IC. This pin is of the open-drain output type and when an unusual condition is detected, the EMO output is placed in the ON (EMO = Low) state.

Furthermore, the EMO pin is placed in the ON state when one of the following conditions occurs.

1. Shorting-to-power, shorting-to-ground, or shorting-to-load occurs at the output pin and the output short-circuit protection circuit is activated.
2. The IC junction temperature rises and the thermal protection circuit is activated.

## Charge Pump Circuit

When the ST pin is set High, the charge pump circuit operates and the VG pin voltage is boosted from the VM voltage to the VM + VREG5 voltage. If the VG pin voltage is not boosted sufficiently, the output cannot be controlled, so be sure to provide a wait time of tONG or more after setting the ST pin High before starting to drive the motor.

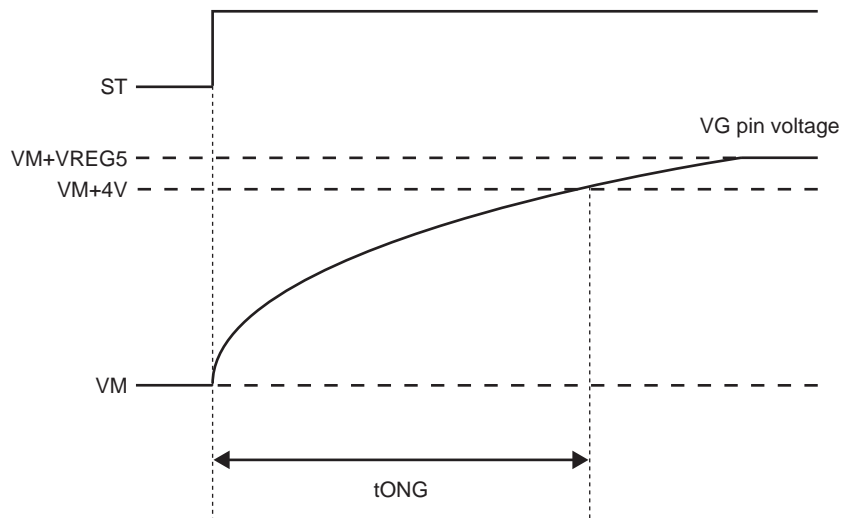

VG Pin Voltage Schematic View



**Application Circuit Example**

- Stepping motor driver circuit

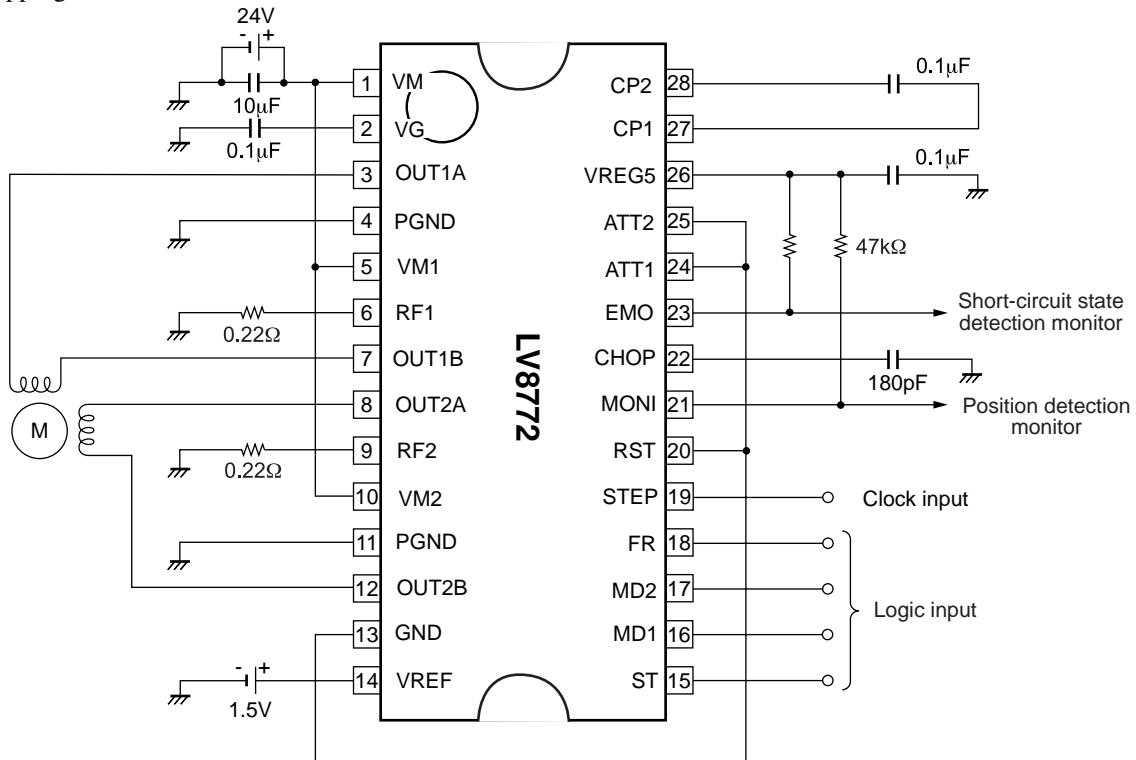

The formulae for setting the constants in the examples of the application circuits above are as follows :

Constant current (100%) setting

When VREF = 1.5V

$$I_{OUT} = VREF/5/RF \text{ resistance}$$

$$= 1.5V/5/0.22\Omega = 1.36A$$

Chopping frequency setting

$$F_{chop} = I_{chop}/(C_{chop} \times V_{tchop} \times 2)$$

$$= 10\mu A/(180pF \times 0.5V \times 2) = 55kHz$$

ON Semiconductor and the ON logo are registered trademarks of Semiconductor Components Industries, LLC (SCILLC). SCILLC owns the rights to a number of patents, trademarks, copyrights, trade secrets, and other intellectual property. A listing of SCILLC's product/patent coverage may be accessed at [www.onsemi.com/site/pdf/Patent-Marking.pdf](http://www.onsemi.com/site/pdf/Patent-Marking.pdf). SCILLC reserves the right to make changes without further notice to any products herein. SCILLC makes no warranty, representation or guarantee regarding the suitability of its products for any particular purpose, nor does SCILLC assume any liability arising out of the application or use of any product or circuit, and specifically disclaims any and all liability, including without limitation special, consequential or incidental damages. "Typical" parameters which may be provided in SCILLC data sheets and/or specifications can and do vary in different applications and actual performance may vary over time. All operating parameters, including "Typicals" must be validated for each customer application by customer's technical experts. SCILLC does not convey any license under its patent rights nor the rights of others. SCILLC products are not designed, intended, or authorized for use as components in systems intended for surgical implant into the body, or other applications intended to support or sustain life, or for any other application in which the failure of the SCILLC product could create a situation where personal injury or death may occur. Should Buyer purchase or use SCILLC products for any such unintended or unauthorized application, Buyer shall indemnify and hold SCILLC and its officers, employees, subsidiaries, affiliates, and distributors harmless against all claims, costs, damages, and expenses, and reasonable attorney fees arising out of, directly or indirectly, any claim of personal injury or death associated with such unintended or unauthorized use, even if such claim alleges that SCILLC was negligent regarding the design or manufacture of the part. SCILLC is an Equal Opportunity/Affirmative Action Employer. This literature is subject to all applicable copyright laws and is not for resale in any manner.