

# MC10H136

## Universal Hexadecimal Counter

### Description

The MC10H136 is a high speed synchronous hexadecimal counter. This 10H part is a functional/pinout duplication of the standard MECL 10K™ family part, with 100% improvement in counting frequency and no increase in power-supply current.

### Features

- Counting Frequency, 250 MHz Minimum
- Power Dissipation, 625 mW Typical
- Improved Noise Margin 150 mV (Over Operating Voltage and Temperature Range)
- Voltage Compensated
- MECL 10K Compatible
- These Devices are Pb-Free, Halogen Free and are RoHS Compliant



**ON Semiconductor®**

[www.onsemi.com](http://www.onsemi.com)

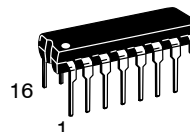

**PDIP-16  
P SUFFIX  
CASE 648-08**

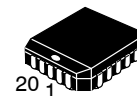

**PLCC-20  
FN SUFFIX  
CASE 775-02**

### MARKING DIAGRAMS\*

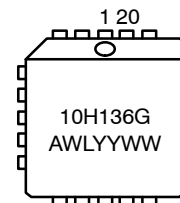

- A = Assembly Location
- WL = Wafer Lot
- YY = Year
- WW = Work Week
- G = Pb-Free Package

\*For additional marking information, refer to Application Note [AND8002/D](#).

### ORDERING INFORMATION

Device	Package	Shipping†
MC10H136FNG	PLCC-28 (Pb-Free)	46 Units/Tube
MC10H136PG	PDIP-16 (Pb-Free)	25 Units/Tube

†For information on tape and reel specifications, including part orientation and tape sizes, please refer to our Tape and Reel Packaging Specifications Brochure, [BRD8011/D](#).

# MC10H136

**Table 1. FUNCTION SELECT TABLE**

CIN	S1	S2	Operating Mode
X	L	L	Preset (Program)
L	L	H	Increment (Count Up)
H	L	H	Hold Count
L	H	L	Decrement (Count Down)
H	H	L	Hold Count
X	H	H	Hold (Stop Count)

**Table 2. SEQUENTIAL TRUTH TABLE\***

INPUTS									OUTPUTS				
S1	S2	D0	D1	D2	D3	Carry In	Clock **	Q0	Q1	Q2	Q3	Carry Out	
L	L	L	L	H	H	X	H	L	L	H	H	L	
L	H	X	X	X	X	L	H	L	L	H	H	H	
L	H	X	X	X	X	L	H	L	H	H	H	H	
L	H	X	X	X	X	L	H	H	H	H	H	L	
L	H	X	X	X	X	H	L	H	H	H	H	H	
L	H	X	X	X	X	H	H	H	H	H	H	H	
H	H	X	X	X	X	X	H	H	H	H	H	H	
L	L	H	H	L	L	X	H	H	H	L	L	L	
H	L	X	X	X	X	L	H	L	H	L	L	H	
H	L	X	X	X	X	L	H	H	L	L	L	L	
H	L	X	X	X	X	L	H	H	L	L	L	L	
H	L	X	X	X	X	L	H	H	L	L	L	L	

\* Truth table shows logic states assuming inputs vary in sequence shown from top to bottom.

\*\* A clock H is defined as a clock input transition from a low to a high logic level.

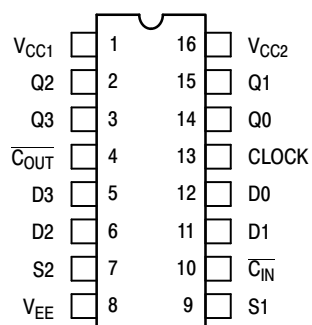

Pin assignment is for Dual-in-Line Package.

**Figure 1. Pin Assignment**

**Table 3. MAXIMUM RATINGS**

Symbol	Characteristic	Rating	Unit
$V_{EE}$	Power Supply ( $V_{CC} = 0$ )	-8.0 to 0	Vdc
$V_I$	Input Voltage ( $V_{CC} = 0$ )	0 to $V_{EE}$	Vdc
$I_{out}$	Output Current Continuous Surge	50 100	mA
$T_A$	Operating Temperature Range	0 to +75	°C
$T_{stg}$	Storage Temperature Range Plastic Ceramic	-55 to +150 -55 to +165	°C

Stresses exceeding those listed in the Maximum Ratings table may damage the device. If any of these limits are exceeded, device functionality should not be assumed, damage may occur and reliability may be affected.

**Table 4. ELECTRICAL CHARACTERISTICS** ( $V_{EE} = -5.2 \text{ V} \pm 5\%$ ) (Note 1)

Symbol	Characteristic	0°		25°		75°		Unit
		Min	Max	Min	Max	Min	Max	
$I_E$	Power Supply Current	-	165	-	150	-	165	mA
$I_{inH}$	Input Current High Pins 5, 6, 11, 12, 13	-	430	-	275	-	275	$\mu\text{A}$
	Pin 9	-	670	-	420	-	420	
	Pin 7	-	535	-	335	-	335	
	Pin 10	-	380	-	240	-	240	
$I_{inL}$	Input Current Low	0.5	-	0.5	-	0.3	-	$\mu\text{A}$
$V_{OH}$	High Output Voltage	-1.02	-0.84	-0.98	-0.81	-0.92	-0.735	Vdc
$V_{OL}$	Low Output Voltage	-1.95	-1.63	-1.95	-1.63	-1.95	-1.60	Vdc
$V_{IH}$	High Input Voltage	-1.17	-0.84	-1.13	-0.81	-1.07	-0.735	Vdc
$V_{IL}$	Low Input Voltage	-1.95	-1.48	-1.95	-1.48	-1.95	-1.45	Vdc

- Each MECL 10H™ series circuit has been designed to meet the dc specifications shown in the test table, after thermal equilibrium has been established. The circuit is in a test socket or mounted on a printed circuit board and transverse air flow greater than 500 lfpm is maintained. Outputs are terminated through a 50  $\Omega$  resistor to -2.0 V.

# MC10H136

**Table 5. AC CHARACTERISTICS**

Symbol	Characteristic	0°		25°		75°		Unit
		Min	Max	Min	Max	Min	Max	
$t_{pd}$	Propagation Delay	0.7	2.3	0.7	2.4	0.7	2.5	ns
	Clock to Q	1.0	4.8	1.0	4.9	1.0	5.0	
	Clock to Carry Out Carry in to Carry Out	0.7	2.5	0.7	2.6	0.7	2.7	
$t_{set}$	Set-up Time	2.0	-	2.0	-	2.0	-	ns
	Data (D0 to C)	3.5	-	3.5	-	3.5	-	
	Select (S to C)	2.0	-	2.0	-	2.0	-	
	Carry In ( $C_{in}$ to C) (C to $C_{in}$ )	0	-	0	-	0	-	
$t_{hold}$	Hold Time	0	-	0	-	0	-	ns
	Data (C to D0)	-0.5	-	-0.5	-	-0.5	-	
	Select (C to S)	0	-	0	-	0	-	
	Carry In (C to $C_{in}$ ) ( $C_{in}$ to C)	2.2	-	2.2	-	2.2	-	
	Counting Frequency	250	-	250	-	250	-	
$t_r$	Rise Time	0.5	2.3	0.5	2.4	0.5	2.5	ns
$t_f$	Fall Time	0.5	2.3	0.5	2.4	0.5	2.5	ns

NOTE: Device will meet the specifications after thermal equilibrium has been established when mounted in a test socket or printed circuit board with maintained transverse airflow greater than 500 lfm. Electrical parameters are guaranteed only over the declared operating temperature range. Functional operation of the device exceeding these conditions is not implied. Device specification limit values are applied individually under normal operating conditions and not valid simultaneously.

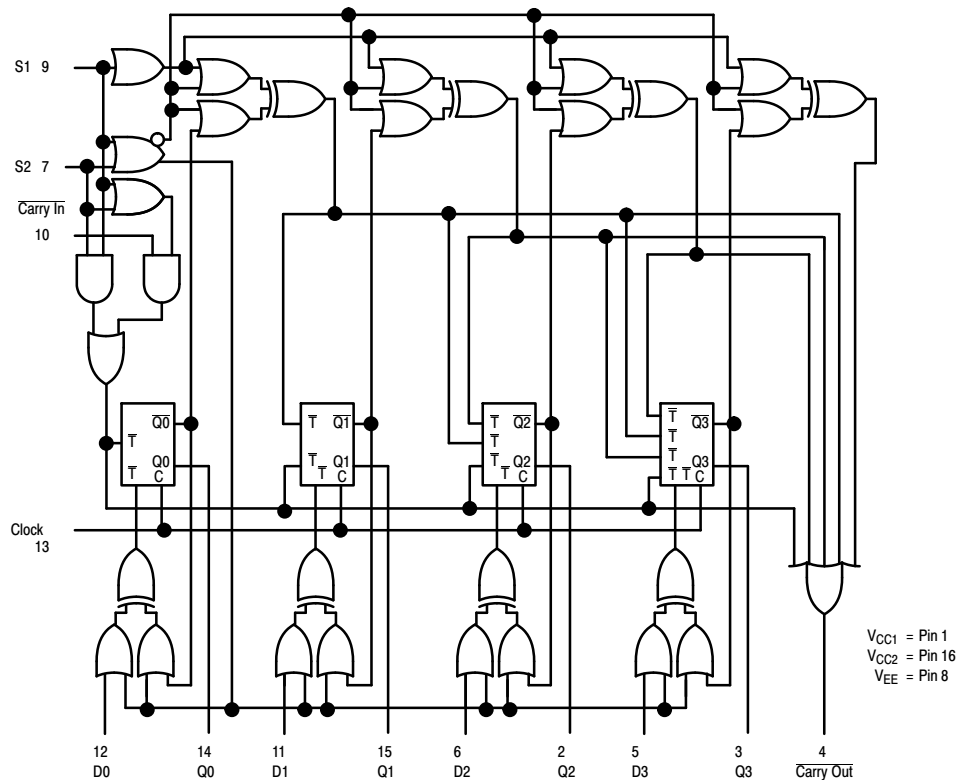

NOTE: FLIP-FLOPS WILL TOGGLE WHEN ALL T INPUTS ARE LOW.

**Figure 2. Logic Diagram**

# MC10H136

## APPLICATION INFORMATION

The MC10H136 is a high speed synchronous counter that operates at 250 MHz. Counter operating modes include count up, count down, pre-set and hold count. This device allows the designer to use one basic counter for many applications.

The S1, S2, control lines determine the operating modes of the counter. In the pre-set mode, a clock pulse is necessary to load the counter with the information present on the data inputs (D0, D1, D2, and D3). Carry out goes low on the terminal count or when the counter is being pre-set.

# MC10H136

## PACKAGE DIMENSIONS

20 LEAD PLLC  
CASE 775-02  
ISSUE F

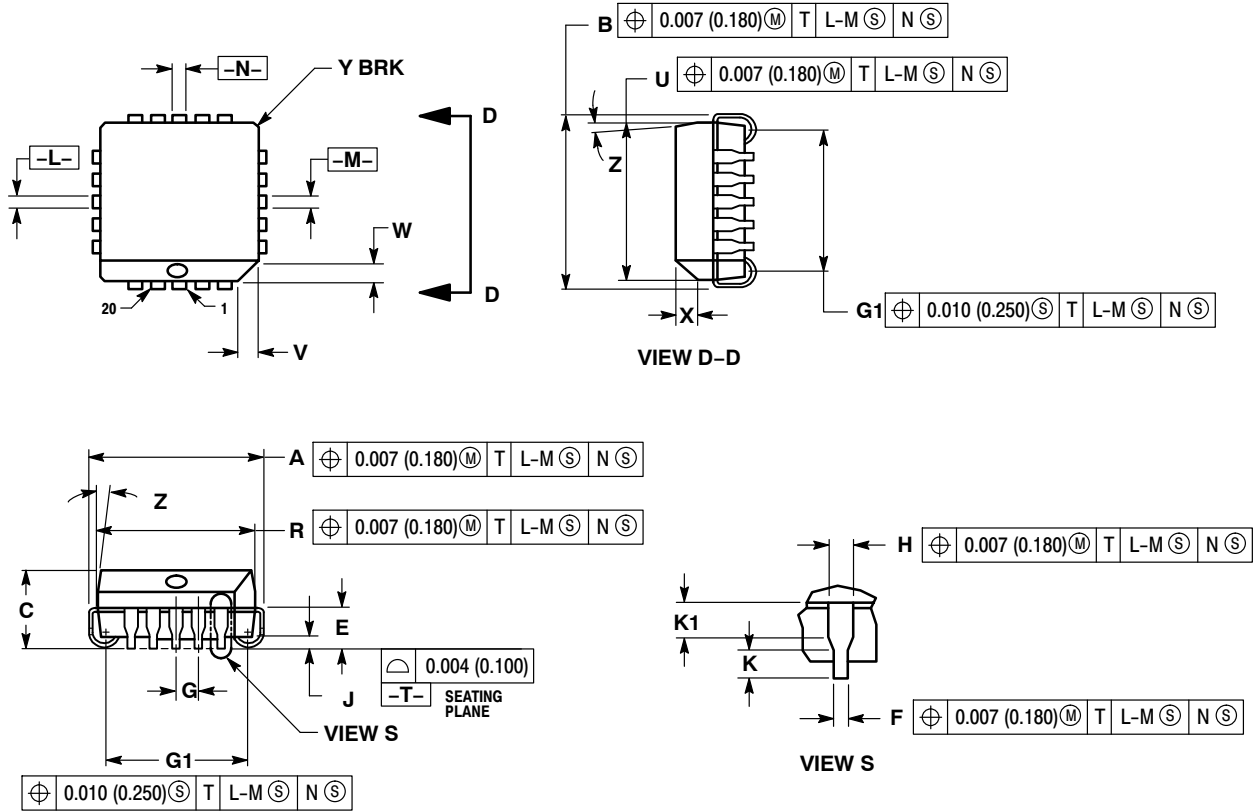

**NOTES:**

1. DIMENSIONS AND TOLERANCING PER ANSI Y14.5M, 1982.
2. DIMENSIONS IN INCHES.
3. DATUMS -L-, -M-, AND -N- DETERMINED WHERE TOP OF LEAD SHOULDER EXITS PLASTIC BODY AT MOLD PARTING LINE.
4. DIMENSION G1, TRUE POSITION TO BE MEASURED AT DATUM -T-, SEATING PLANE.
5. DIMENSIONS R AND U DO NOT INCLUDE MOLD FLASH. ALLOWABLE MOLD FLASH IS 0.010 (0.250) PER SIDE.
6. DIMENSIONS IN THE PACKAGE TOP MAY BE SMALLER THAN THE PACKAGE BOTTOM BY UP TO 0.012 (0.300). DIMENSIONS R AND U ARE DETERMINED AT THE OUTERMOST EXTREMES OF THE PLASTIC BODY EXCLUSIVE OF MOLD FLASH, TIE BAR BURRS, GATE BURRS AND INTERLEAD FLASH, BUT INCLUDING ANY MISMATCH BETWEEN THE TOP AND BOTTOM OF THE PLASTIC BODY.
7. DIMENSION H DOES NOT INCLUDE DAMBAR PROTRUSION OR INTRUSION. THE DAMBAR PROTRUSION(S) SHALL NOT CAUSE THE H DIMENSION TO BE GREATER THAN 0.037 (0.940). THE DAMBAR INTRUSION(S) SHALL NOT CAUSE THE H DIMENSION TO BE SMALLER THAN 0.025 (0.635).

DIM	INCHES		MILLIMETERS	
	MIN	MAX	MIN	MAX
A	0.385	0.395	9.78	10.03
B	0.385	0.395	9.78	10.03
C	0.165	0.180	4.20	4.57
E	0.090	0.110	2.29	2.79
F	0.013	0.021	0.33	0.53
G	0.050 BSC		1.27 BSC	
H	0.026	0.032	0.66	0.81
J	0.020	----	0.51	----
K	0.025	----	0.64	----
R	0.350	0.356	8.89	9.04
U	0.350	0.356	8.89	9.04
V	0.042	0.048	1.07	1.21
W	0.042	0.048	1.07	1.21
X	0.042	0.056	1.07	1.42
Y	----	0.020	----	0.50
Z	2° 10°		2° 10°	
G1	0.310	0.330	7.88	8.38
K1	0.040	----	1.02	----