

# AMIS-42673

## High-Speed 3.3 V Digital Interface CAN Transceiver

### Description

The AMIS-42673 CAN transceiver is the interface between a controller area network (CAN) protocol controller and the physical bus. It may be used in both 12V and 24 V systems. The digital interface level is powered from a 3.3 V supply providing true I/O voltage levels for 3.3 V CAN controllers.

The transceiver provides differential transmit capability to the bus and differential receive capability to the CAN controller. Due to the wide common-mode voltage range of the receiver inputs, the AMIS-42673 is able to reach outstanding levels of electromagnetic susceptibility (EMS). Similarly, extremely low electromagnetic emission (EME) is achieved by the excellent matching of the output signals.

The AMIS-42673 is primarily intended for applications where long network lengths are mandatory. Examples are elevators, in-building networks, process control and trains. To cope with the long bus delay the communication speed needs to be low. AMIS-42673 allows low transmit data rates down to 10 kbit/s or lower.

### Features

- True 3.3 V or 5.0 V Logic Level Interface
- Fully Compatible with the “ISO 11898-2” Standard
- Wide Range of Bus Communication Speed (0 up to 1 Mbit/s)
- Allows Low Transmit Data Rate in Networks Exceeding 1 km
- Ideally Suited for 12 V and 24 V Applications
- Low Electromagnetic Emission (EME); Common-Mode-Choke is No Longer Required
- Differential Receiver with Wide Common-Mode Range ( $\pm 35$  V) for High Electromagnetic Susceptibility (EMS)
- No Disturbance of the Bus Lines with an Unpowered Node
- Thermal Protection
- Bus Pins Protected Against Transients
- Short Circuit Proof to Supply Voltage and Ground
- ESD Protection for CAN Bus at  $\pm 8$  kV
- These are Pb-Free Devices\*

\*For additional information on our Pb-Free strategy and soldering details, please download the ON Semiconductor Soldering and Mounting Techniques Reference Manual, SOLDERRM/D.



ON Semiconductor®

<http://onsemi.com>

### PIN ASSIGNMENT

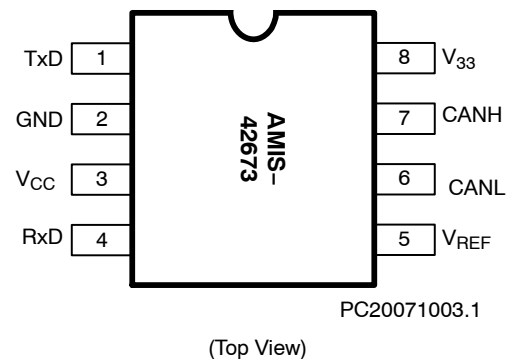

### ORDERING INFORMATION

See detailed ordering and shipping information in the package dimensions section on page 10 of this data sheet.

Table 1. TECHNICAL CHARACTERISTICS

Symbol	Parameter	Condition	Max	Max	Unit
$V_{CANH}$	DC Voltage at Pin CANH	$0 < V_{CC} < 5.25 \text{ V}$ ; No Time Limit	-45	+45	V
$V_{CANL}$	DC Voltage at Pin CANL	$0 < V_{CC} < 5.25 \text{ V}$ ; No Time Limit	-45	+45	V
$V_{o(dif)(bus\_dom)}$	Differential Bus Output Voltage in Dominant State	$42.5 \Omega < R_{LT} < 60 \Omega$	1.5	3	V
$t_{pd(rec-dom)}$	Propagation Delay TxD to RxD		100	230	ns
$t_{pd(dom-rec)}$	Propagation Delay TxD to RxD		100	245	ns
$C_{M-range}$	Input Common-Mode Range for Comparator	Guaranteed Differential Receiver Threshold and Leakage Current	-35	+35	V
$V_{CM-peak}$	Common-Mode Peak	Figures 7 and 8 (Note 1)	-500	500	mV
$V_{CM-step}$	Common-Mode Step	Figures 7 and 8 (Note 1)	-150	150	mV

1. The parameters  $V_{CM-peak}$  and  $V_{CM-step}$  guarantee low EME.

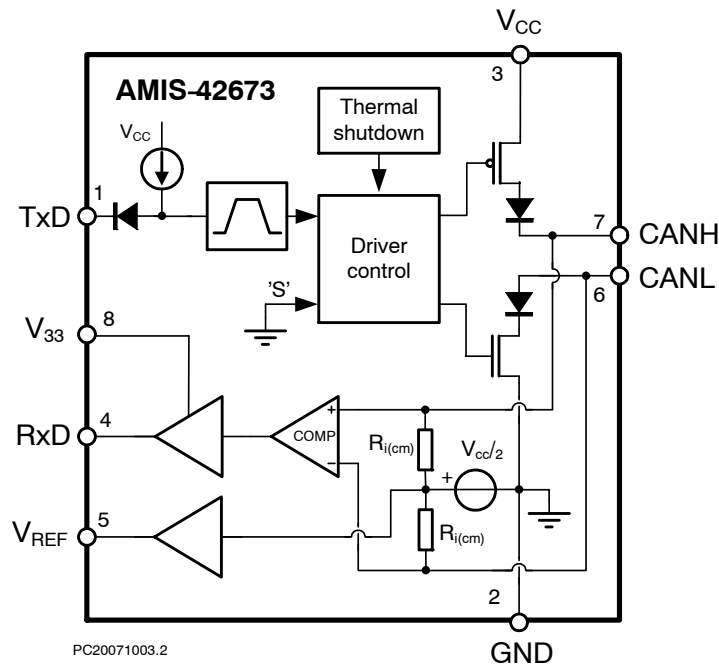

Figure 1. Block Diagram

Table 2. PIN DESCRIPTION

Pin	Name	Description
1	TxD	Transmit Data Input; Low Input → Dominant Driver; Internal Pullup Current
2	GND	Ground
3	$V_{CC}$	Supply Voltage
4	RxD	Receive Data Output; Dominant Transmitter → Low Output
5	$V_{REF}$	Reference Voltage Output
6	CANL	LOW-Level CAN Bus Line (Low in Dominant Mode)
7	CANH	HIGH-Level CAN Bus Line (High in Dominant Mode)
8	$V_{33}$	3.3 V Supply for Digital I/O

**Table 3. ABSOLUTE MAXIMUM RATINGS**

Symbol	Parameter	Conditions	Min	Max	Unit
V <sub>CC</sub>	Supply Voltage		-0.3	+7	V
V <sub>33</sub>	I/O Interface Voltage		-0.3	+7	V
V <sub>CANH</sub>	DC Voltage at Pin CANH	0 < V <sub>CC</sub> < 5.25 V; No Time Limit	-45	+45	V
V <sub>CANL</sub>	DC Voltage at Pin CANL	0 < V <sub>CC</sub> < 5.25 V; No Time Limit	-45	+45	V
V <sub>TxD</sub>	DC Voltage at Pin TxD		-0.3	V <sub>CC</sub> + 0.3	V
V <sub>RxD</sub>	DC Voltage at Pin RxD		-0.3	V <sub>CC</sub> + 0.3	V
V <sub>REF</sub>	DC Voltage at Pin V <sub>REF</sub>		-0.3	V <sub>CC</sub> + 0.3	V
V <sub>tran</sub> (CANH)	Transient Voltage at Pin CANH	Note 2	-150	+150	V
V <sub>tran</sub> (CANL)	Transient Voltage at Pin CANL	Note 2	-150	+150	V
V <sub>tran</sub> (VREF)	Transient Voltage at Pin V <sub>REF</sub>	Note 2	-150	+150	V
V <sub>esd</sub> (CANL/ CANH)	Electrostatic Discharge Voltage at CANH and CANL Pin	Note 4 Note 6	-8 -500	+8 +500	kV V
V <sub>esd</sub>	Electrostatic Discharge Voltage at All Other Pins	Note 4 Note 6	-4 -250	+4 +250	kV V
Latch-up	Static Latch-up at All Pins	Note 5		100	mA
T <sub>stg</sub>	Storage Temperature		-55	+155	°C
T <sub>A</sub>	Ambient Temperature		-40	+125	°C
T <sub>J</sub>	Maximum Junction Temperature		-40	+150	°C

Stresses exceeding Maximum Ratings may damage the device. Maximum Ratings are stress ratings only. Functional operation above the Recommended Operating Conditions is not implied. Extended exposure to stresses above the Recommended Operating Conditions may affect device reliability.

2. Applied transient waveforms in accordance with “ISO 7637 part 3”, test pulses 1, 2, 3a, and 3b (see Figure 4).
3. Standardized human body model system ESD pulses in accordance to IEC 1000.4.2.
4. Standardized human body model ESD pulses in accordance to MIL883 method 3015. Supply pin 8 is ±4kV.
5. Static latch-up immunity: static latch-up protection level when tested according to EIA/JESD78.
6. Standardized charged device model ESD pulses when tested according to EOS/ESD DS5.3-1993.

**Table 4. THERMAL CHARACTERISTICS**

Symbol	Parameter	Conditions	Value	Unit
R <sub>th</sub> (vj-a)	Thermal Resistance from Junction-to-Ambient in SO-8 Package	In Free Air	145	k/W
R <sub>th</sub> (vj-s)	Thermal Resistance from Junction-to-Substrate of Bare Die	In Free Air	45	k/W

# AMIS-42673

## APPLICATION INFORMATION

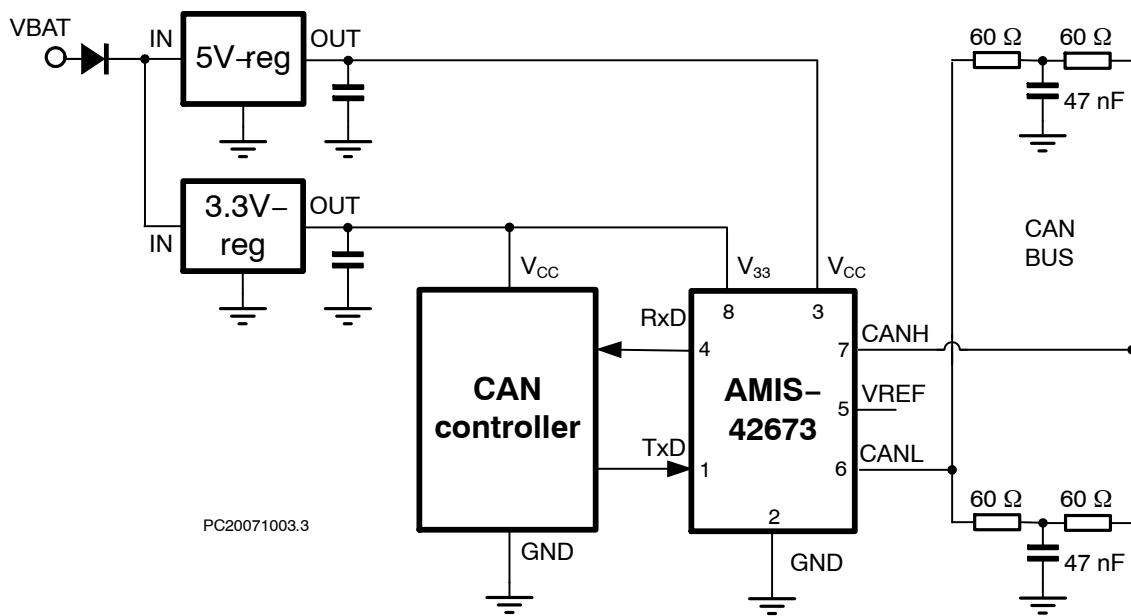

Figure 2. Application Diagram

FUNCTIONAL DESCRIPTION

**General**

The AMIS-42673 is the interface between the CAN protocol controller and the physical bus. It is intended for use in industrial and automotive applications requiring baud rates up to 1 Mbit/s. It provides differential transmit capability to the bus and differential receiver capability to the CAN protocol controller. It is fully compatible to the “ISO 11898-2” standard.

**Operating Modes**

AMIS-42673 only operates in high-speed mode as illustrated in Table 5.

The transceiver is able to communicate via the bus lines. The signals are transmitted and received to the CAN controller via the pins TxD and RxD. The slopes on the bus lines outputs are optimized to give extremely low EME.

**Table 5. FUNCTIONAL TABLE OF AMIS-42673; x = don't care**

V <sub>CC</sub>	Pin TxD	Pin CANH	Pin CANL	Bus State	Pin RxD
4.75 to 5.25 V	0	High	Low	Dominant	0
4.75 to 5.25 V	1 (or floating)	V <sub>CC</sub> /2	V <sub>CC</sub> /2	Recessive	1
V <sub>CC</sub> < PORL (Unpowered)	x	0 V < CANH < V <sub>CC</sub>	0 V < CANL < V <sub>CC</sub>	Recessive	1
PORL < V <sub>CC</sub> < 4.75 V	> 2 V	0 V < CANH < V <sub>CC</sub>	0 V < CANL < V <sub>CC</sub>	Recessive	1

**Overtemperature Detection**

A thermal protection circuit protects the IC from damage by switching off the transmitter if the junction temperature exceeds a value of approximately 160°C. Because the transmitter dissipates most of the power, the power dissipation and temperature of the IC is reduced. All other IC functions continue to operate. The transmitter off-state resets when Pin TxD goes HIGH. The thermal protection circuit is particularly needed when a bus line short circuits.

**High Communication Speed Range**

The transceiver is primarily intended for industrial applications. It allows very low baud rates needed for long bus length applications. But also high speed communication is possible up to 1 Mbit/s.

**Fail-Safe Features**

A current-limiting circuit protects the transmitter output stage from damage caused by accidental short-circuit to either positive or negative supply voltage – although power dissipation increases during this fault condition.

The pins CANH and CANL are protected from automotive electrical transients (according to “ISO 7637”; see Figure 3).

Should TxD become disconnected, this pin is pulled high internally.

When the V<sub>CC</sub> supply is removed, Pins TxD and RxD will be floating. This prevents the AMIS-42673 from being supplied by the CAN controller through the I/O Pins.

**3.3 V Interface**

AMIS-42673 may be used to interface with 3.3 V or 5 V controllers by use of the V<sub>33</sub> pin. This pin may be supplied with 3.3 V or 5 V to have the corresponding digital interface voltage levels.

When the V<sub>33</sub> pin is supplied at 2.5 V, even interfacing with 2.5 V CAN controllers is possible. See also Digital Output Characteristics @ V<sub>33</sub> = 2.5 V, Table . In this case a pull-up resistor from TxD to V<sub>33</sub> is necessary.



# AMIS-42673

**Table 6. DC CHARACTERISTICS**  $V_{CC} = 4.75\text{ V to }5.25\text{ V}$ ,  $V_{33} = 2.9\text{ V to }3.6\text{ V}$ ;  $T_J = -40^\circ\text{C to }+150^\circ\text{C}$ ;  $R_{LT} = 60\ \Omega$  unless specified otherwise.

Symbol	Parameter	Conditions	Min	Typ	Max	Unit
<b>BUS LINES (Pins CANH and CANL)</b>						
$V_{ihcm(dif)}(th)$	Differential Receiver Threshold Voltage for High Common-Mode	$-35\text{ V} < V_{CANL} < +35\text{ V}$ ; $-35\text{ V} < V_{CANH} < +35\text{ V}$ ; See Figure 4	0.25	0.7	1.05	V
$V_{i(dif)}(hys)$	Differential Receiver Input Voltage Hysteresis	$-35\text{ V} < V_{CANL} < +35\text{ V}$ ; $-35\text{ V} < V_{CANH} < +35\text{ V}$ ; See Figure 4	50	70	100	mV
$R_{i(cm)}(CANH)$	Common-Mode Input Resistance at Pin CANH		15	25	37	k $\Omega$
$R_{i(cm)}(CANL)$	Common-Mode Input Resistance at Pin CANL		15	25	37	k $\Omega$
$R_{i(cm)}(m)$	Matching Between Pin CANH and Pin CANL Common-Mode Input Resistance	$V_{CANH} = V_{CANL}$	-3	0	+3	%
$R_{i(dif)}$	Differential Input Resistance		25	50	75	k $\Omega$

**BUS LINES (Pins CANH and CANL)**

$C_{i(CANH)}$	Input Capacitance at Pin CANH	$V_{TxD} = V_{CC}$ ; Not Tested		7.5	20	pF
$C_{i(CANL)}$	Input Capacitance at Pin CANL	$V_{TxD} = V_{CC}$ ; Not Tested		7.5	20	pF
$C_{i(dif)}$	Differential Input Capacitance	$V_{TxD} = V_{CC}$ ; Not Tested		3.75	10	pF
$I_{L(CANH)}$	Input Leakage Current at Pin CANH	$V_{CC} = 0\text{ V}$ ; $V_{CANH} = 5\text{ V}$	10	170	250	$\mu\text{A}$
$I_{L(CANL)}$	Input Leakage Current at Pin CANL	$V_{CC} = 0\text{ V}$ ; $V_{CANL} = 5\text{ V}$	10	170	250	$\mu\text{A}$
$V_{CM-peak}$	Common-Mode Peak During Transition from Dom $\rightarrow$ Rec or Rec $\rightarrow$ Dom	Figures 7 and 8	-500		500	mV
$V_{CM-step}$	Difference in Common-Mode Between Dominant and Recessive State	Figures 7 and 8	-150		150	mV

**POWER-ON-RESET**

PORL	POR Level	CANH, CANL, $V_{ref}$ in Tri-State Below POR Level	2.2	3.5	4.7	V
------	-----------	--	-----	-----	-----	---

**THERMAL SHUTDOWN**

$T_{J(sd)}$	Shutdown Junction Temperature		150	160	180	$^\circ\text{C}$
-------------	-------------------------------	--	-----	-----	-----	------------------

**TIMING CHARACTERISTICS (See Figures 6 and 7)**

$t_{d(TxD-BUSon)}$	Delay TxD to Bus Active		40	85	110	ns
$t_{d(TxD-BUSoff)}$	Delay TxD to Bus Inactive		30	60	110	ns
$t_{d(BUSon-RxD)}$	Delay Bus Active to RxD		25	55	110	ns
$t_{d(BUSoff-RxD)}$	Delay Bus Inactive to RxD		65	100	135	ns
$t_{pd(rec-dom)}$	Propagation Delay TxD to RxD from Recessive to Dominant		100		230	ns
$t_{d(dom-rec)}$	Propagation Delay TxD to RxD from Dominant to Recessive		100		245	ns

7. Not tested at ATE

**Table 7. DIGITAL OUTPUT CHARACTERISTICS @  $V_{33} = 2.5\text{ V}$**   $V_{CC} = 4.75\text{ to }5.25\text{ V}$ ;  $V_{33} = 2.5\text{ V} \pm 5\%$ ;  $T_J = -40\text{ to }+150^\circ\text{C}$ ;  $R_{LT} = 60\ \Omega$  unless specified otherwise.

Symbol	Parameter	Conditions	Min	Typ	Max	Unit
<b>RECEIVER DATA OUTPUT (Pin RxD)</b>						
$I_{oh}$	HIGH-Level Output Current	$V_{OH} > 0.9 \times V_{33}$	-2.6			mA
$I_{ol}$	LOW-Level Output Current	$V_{OL} < 0.1 \times V_{33}$			4	mA

# AMIS-42673

## MEASUREMENT SETUPS AND DEFINITIONS

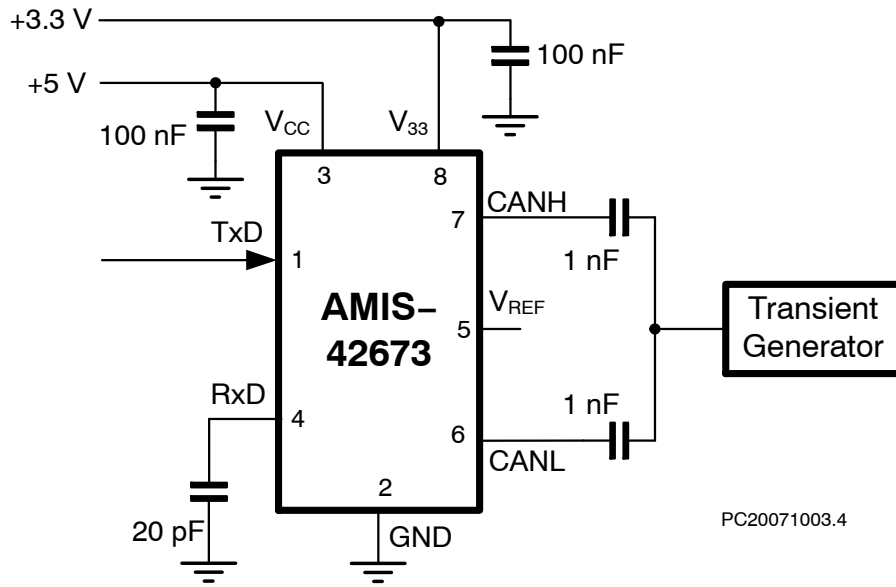

Figure 3. Test Circuit for Automotive Transients

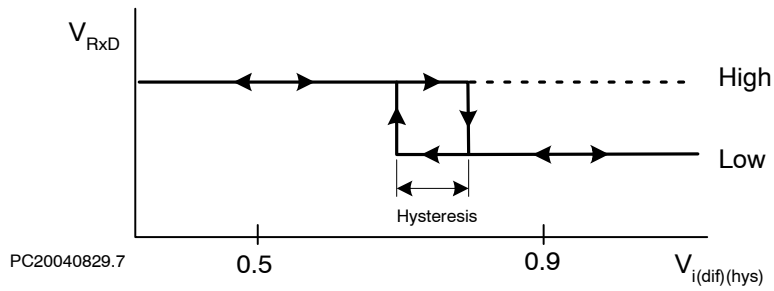

Figure 4. Hysteresis of the Receiver

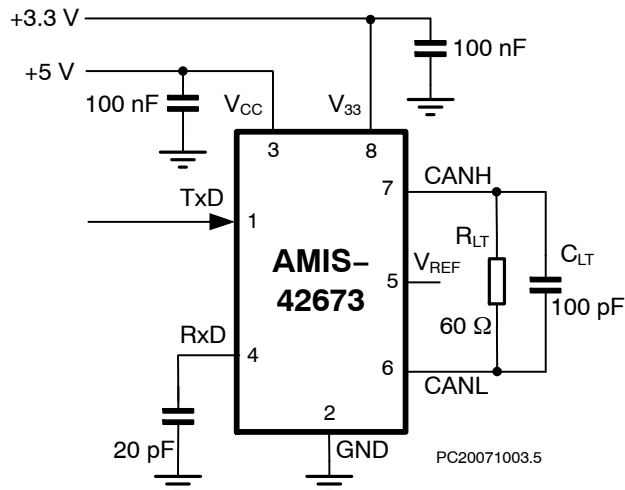

Figure 5. Test Circuit for Timing Characteristics



# AMIS-42673

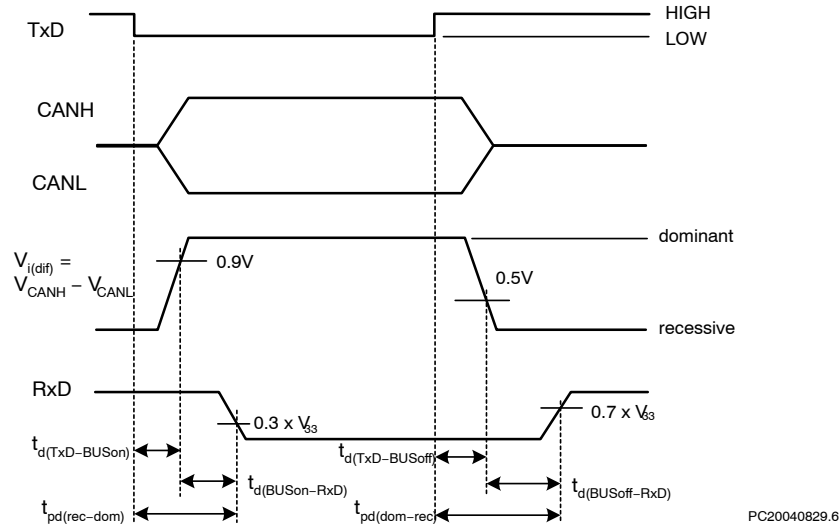

Figure 6. Timing Diagram for AC Characteristics

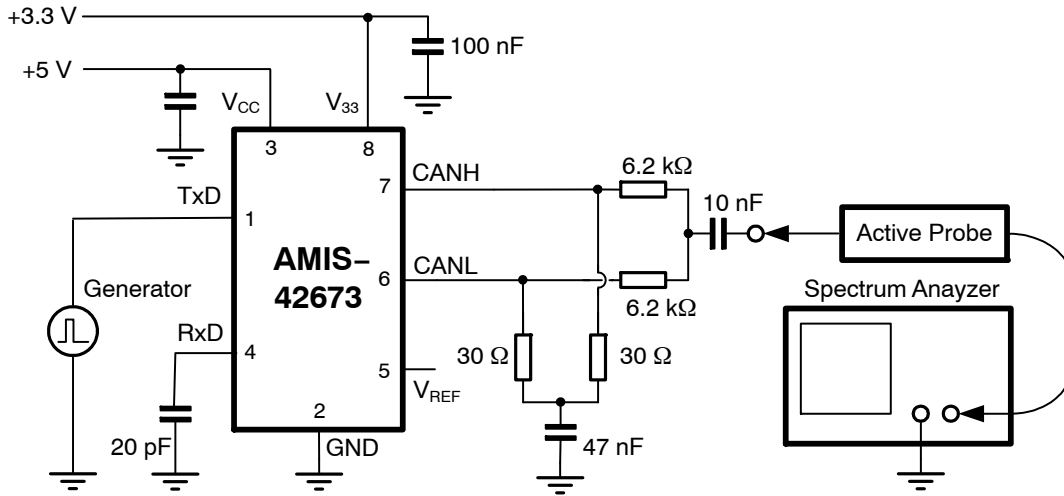

Figure 7. Basic Test Setup for Electromagnetic Measurement

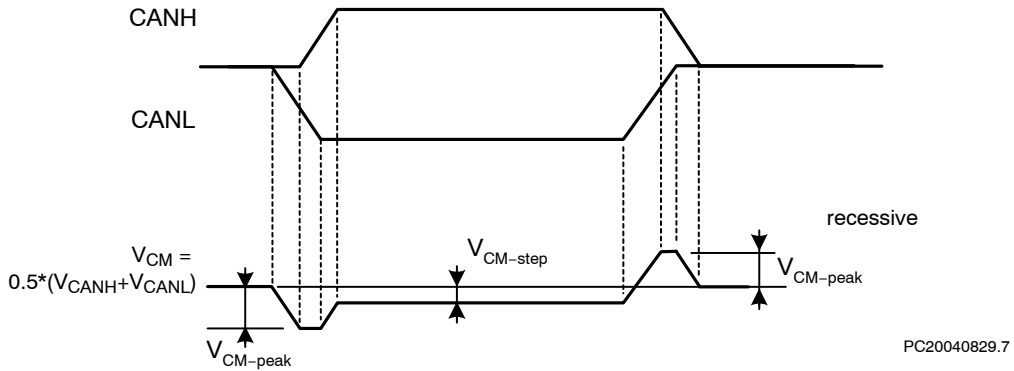

Figure 8. Common-Mode Voltage Peaks (See Measurement Setup Figure 7)

# AMIS-42673

## DEVICE ORDERING INFORMATION

Part Number	Temperature Range	Package Type	Shipping <sup>†</sup>
AMIS42673ICAG1G	-40°C - 125°C	SOIC-8 (Pb-Free)	96 Tube / Tray
AMIS42673ICAG1RG	-40°C - 125°C	SOIC-8 (Pb-Free)	3000 / Tape & Reel

<sup>†</sup>For information on tape and reel specifications, including part orientation and tape sizes, please refer to our Tape and Reel Packaging Specifications Brochure, BRD8011/D.

# AMIS-42673

## PACKAGE DIMENSIONS

SOIC 8  
CASE 751AZ-01  
ISSUE O

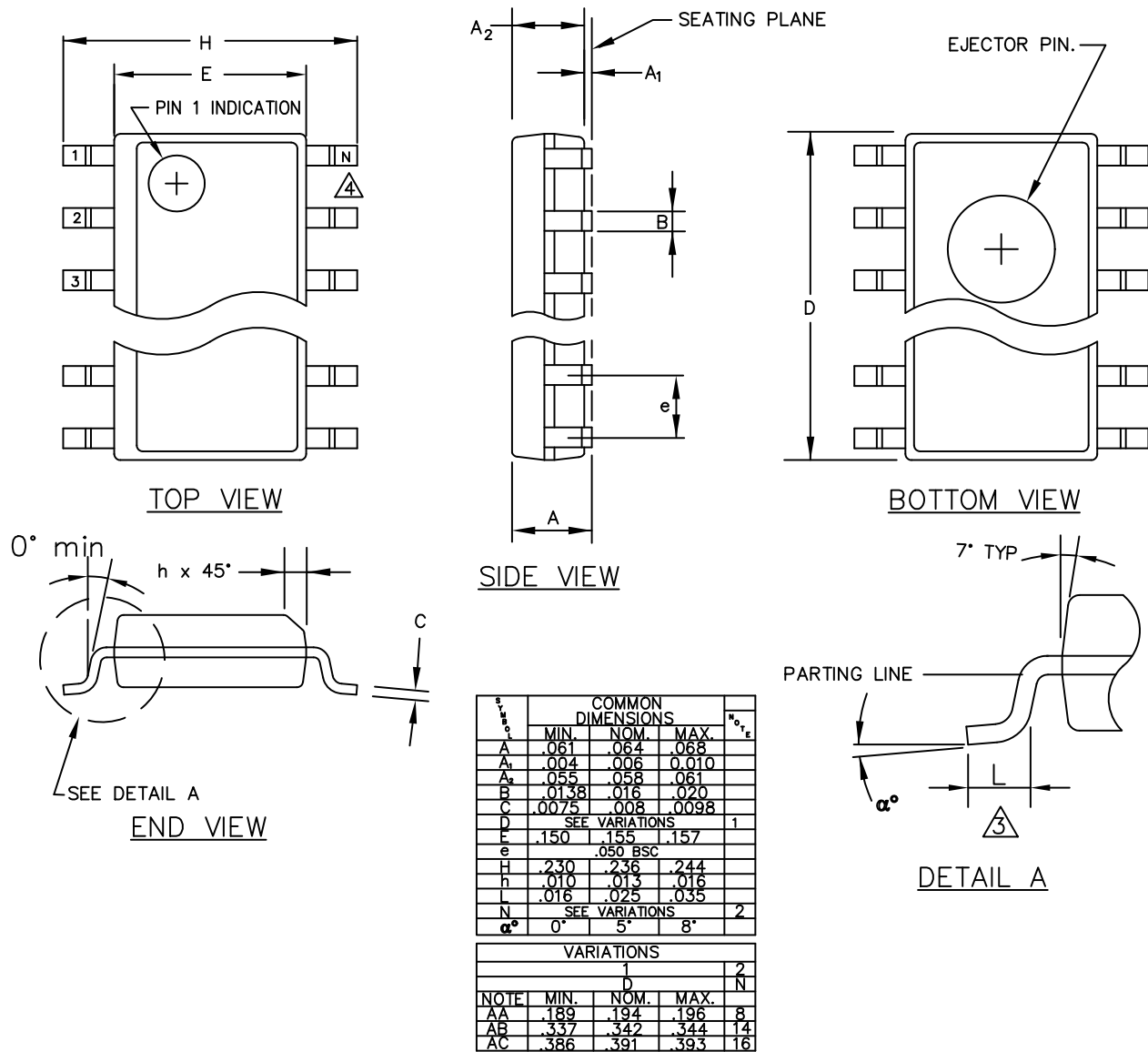

1. ALL DIMENSIONS ARE IN MILLIMETERS.

**ON Semiconductor** and **ON** are registered trademarks of Semiconductor Components Industries, LLC (SCILLC). SCILLC reserves the right to make changes without further notice to any products herein. SCILLC makes no warranty, representation or guarantee regarding the suitability of its products for any particular purpose, nor does SCILLC assume any liability arising out of the application or use of any product or circuit, and specifically disclaims any and all liability, including without limitation special, consequential or incidental damages. "Typical" parameters which may be provided in SCILLC data sheets and/or specifications can and do vary in different applications and actual performance may vary over time. All operating parameters, including "Typicals" must be validated for each customer application by customer's technical experts. SCILLC does not convey any license under its patent rights nor the rights of others. SCILLC products are not designed, intended, or authorized for use as components in systems intended for surgical implant into the body, or other applications intended to support or sustain life, or for any other application in which the failure of the SCILLC product could create a situation where personal injury or death may occur. Should Buyer purchase or use SCILLC products for any such unintended or unauthorized application, Buyer shall indemnify and hold SCILLC and its officers, employees, subsidiaries, affiliates, and distributors harmless against all claims, costs, damages, and expenses, and reasonable attorney fees arising out of, directly or indirectly, any claim of personal injury or death associated with such unintended or unauthorized use, even if such claim alleges that SCILLC was negligent regarding the design or manufacture of the part. SCILLC is an Equal Opportunity/Affirmative Action Employer. This literature is subject to all applicable copyright laws and is not for resale in any manner.

### PUBLICATION ORDERING INFORMATION

**LITERATURE FULFILLMENT:**  
Literature Distribution Center for ON Semiconductor  
P.O. Box 5163, Denver, Colorado 80217 USA  
**Phone:** 303-675-2175 or 800-344-3860 Toll Free USA/Canada  
**Fax:** 303-675-2176 or 800-344-3867 Toll Free USA/Canada  
**Email:** orderlit@onsemi.com

**N. American Technical Support:** 800-282-9855 Toll Free  
USA/Canada  
**Europe, Middle East and Africa Technical Support:**  
Phone: 421 33 790 2910  
**Japan Customer Focus Center**  
Phone: 81-3-5773-3850

**ON Semiconductor Website:** [www.onsemi.com](http://www.onsemi.com)  
**Order Literature:** <http://www.onsemi.com/orderlit>  
For additional information, please contact your local Sales Representative