



# TDA8594

I<sup>2</sup>C-bus controlled 4 × 50 W power amplifier

Rev. 5 — 11 June 2013

Product data sheet

## 1. General description

---

The TDA8594 is a complementary quad Bridge Tied Load (BTL) audio power amplifier made in BCDMOS technology. It contains four independent amplifiers in BTL configuration. Through the I<sup>2</sup>C-bus, diagnosis of temperature warning and clipping level is fully programmable and the information available via two diagnostic pins is selectable. The status of each amplifier (output offset, load or no load, short-circuit or speaker incorrectly connected) can be read separately.

## 2. Features and benefits

---

### 2.1 General

- Operates in legacy mode (non I<sup>2</sup>C-bus) and I<sup>2</sup>C-bus mode (3.3 V and 5 V compliant)
- Three hardware-programmable I<sup>2</sup>C-bus addresses
- Drives 4 Ω or 2 Ω loads
- Speaker fault detection
- Independent short-circuit protection per channel
- Loss of ground and open V<sub>P</sub> safe (with 200 mΩ series impedance and a supply decoupling capacitor of 2200 μF maximum)
- All outputs short-circuit proof to ground, supply voltage and across the load
- All pins short-circuit proof to ground
- Temperature-controlled gain reduction to prevent audio holes at high junction temperatures
- Low battery voltage detection
- Offset detection
- This part has been qualified in accordance with AEC-Q100

### 2.2 I<sup>2</sup>C-bus mode

- DC load detection: open-circuit, short-circuit and load present
- AC load (tweeter) detection
- During start-up, can detect which load is connected so the appropriate gain can be selected without audio pop
- Independently selectable soft mute of front channels (channel 1 and channel 3) and rear channels (channel 2 and channel 4)
- Programmable gain (26 dB and 16 dB) of front channels (channel 1 and channel 3) and rear channels (channel 2 and channel 4)



- Fully programmable diagnostic levels can be set:
  - ◆ Programmable clip detection: 2 %, 5 % or 10 %
  - ◆ Programmable thermal pre-warning
- Selectable information on the DIAG and STB pins:
  - ◆ The STB pin can be programmed/multiplexed with second clip detection
  - ◆ Clip information of each channel can be directed separately to the DIAG pin or the STB pin
  - ◆ Independent enabling of thermal, clip or load fault detection (short across or to V<sub>P</sub> or to ground) on DIAG pin

### 3. Quick reference data

Table 1. Quick reference data

Symbol	Parameter	Conditions	Min	Typ	Max	Unit
V <sub>P</sub>	supply voltage	R <sub>L</sub> = 4 Ω	8	14.4	18	V
I <sub>q</sub>	quiescent current	no load	-	270	400	mA
P <sub>o</sub>	output power	V <sub>P</sub> = 14.4 V				
		R <sub>L</sub> = 4 Ω; THD = 0.5 %	19	22	-	W
		R <sub>L</sub> = 4 Ω; THD = 10 %	26	28	-	W
		R <sub>L</sub> = 4 Ω; maximum power; V <sub>i</sub> = 2 V (RMS) square wave	42	44	-	W
		R <sub>L</sub> = 2 Ω; maximum power; V <sub>i</sub> = 2 V (RMS) square wave	70	75	-	W
THD	total harmonic distortion	R <sub>L</sub> = 4 Ω; f = 1 kHz; P <sub>o</sub> = 1 W to 12 W	-	0.01	0.1	%
V <sub>n(o)</sub>	output noise voltage	filter 20 Hz to 22 kHz; R <sub>S</sub> = 1 kΩ				
		normal mode	-	45	65	μV
		line driver mode	-	22	29	μV

### 4. Ordering information

Table 2. Ordering information

Type number	Package		Version
	Name	Description	
TDA8594J	DBS27P	plastic DIL-bent-SIL (special bent) power package; 27 leads (lead length 6.8 mm)	SOT827-1
TDA8594SD	RDBS27P	plastic rectangular-DIL-bent-SIL (reverse bent) power package; 27 leads (row spacing 2.54 mm)	SOT878-1

### 5. Block diagram

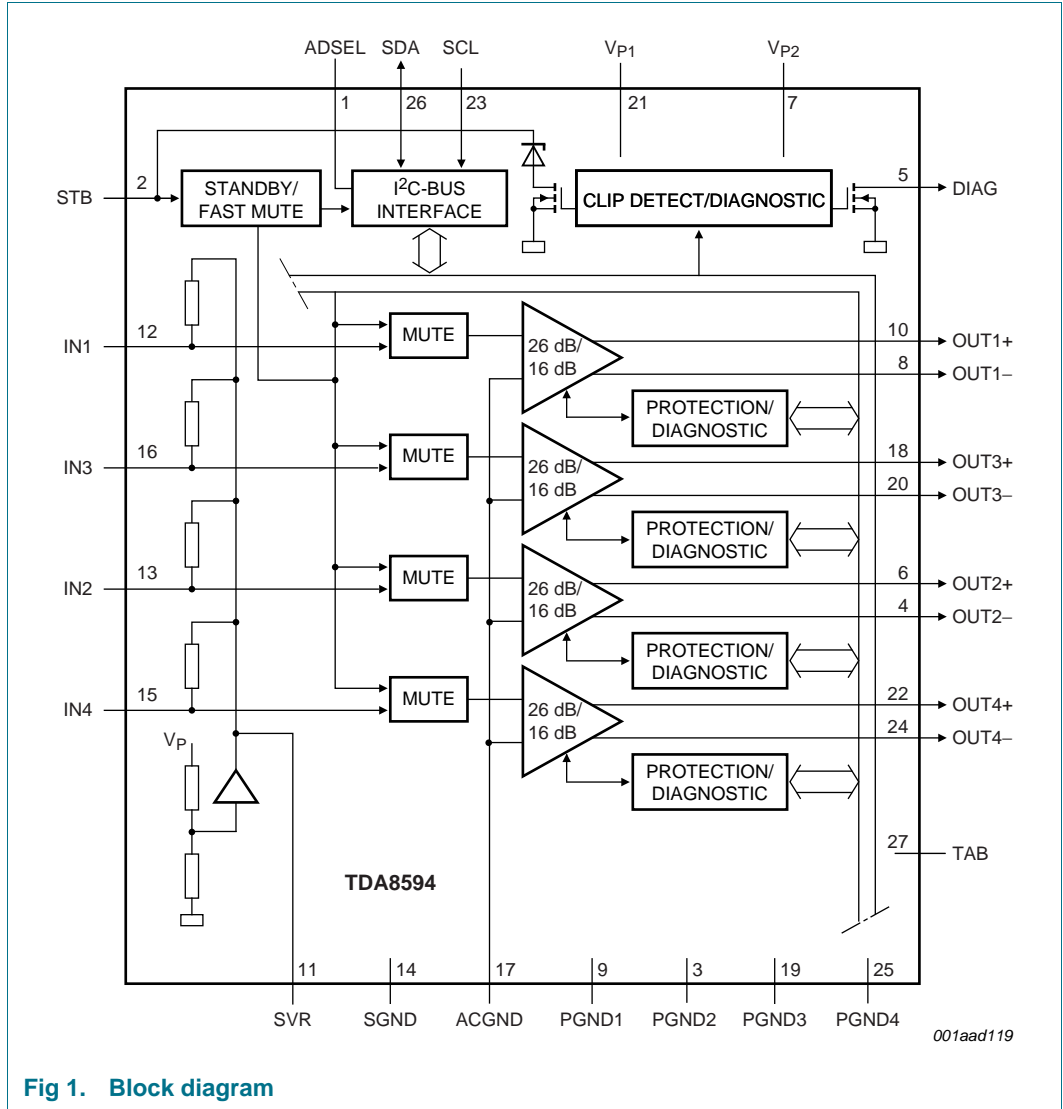

Fig 1. Block diagram

## 6. Pinning information

### 6.1 Pinning

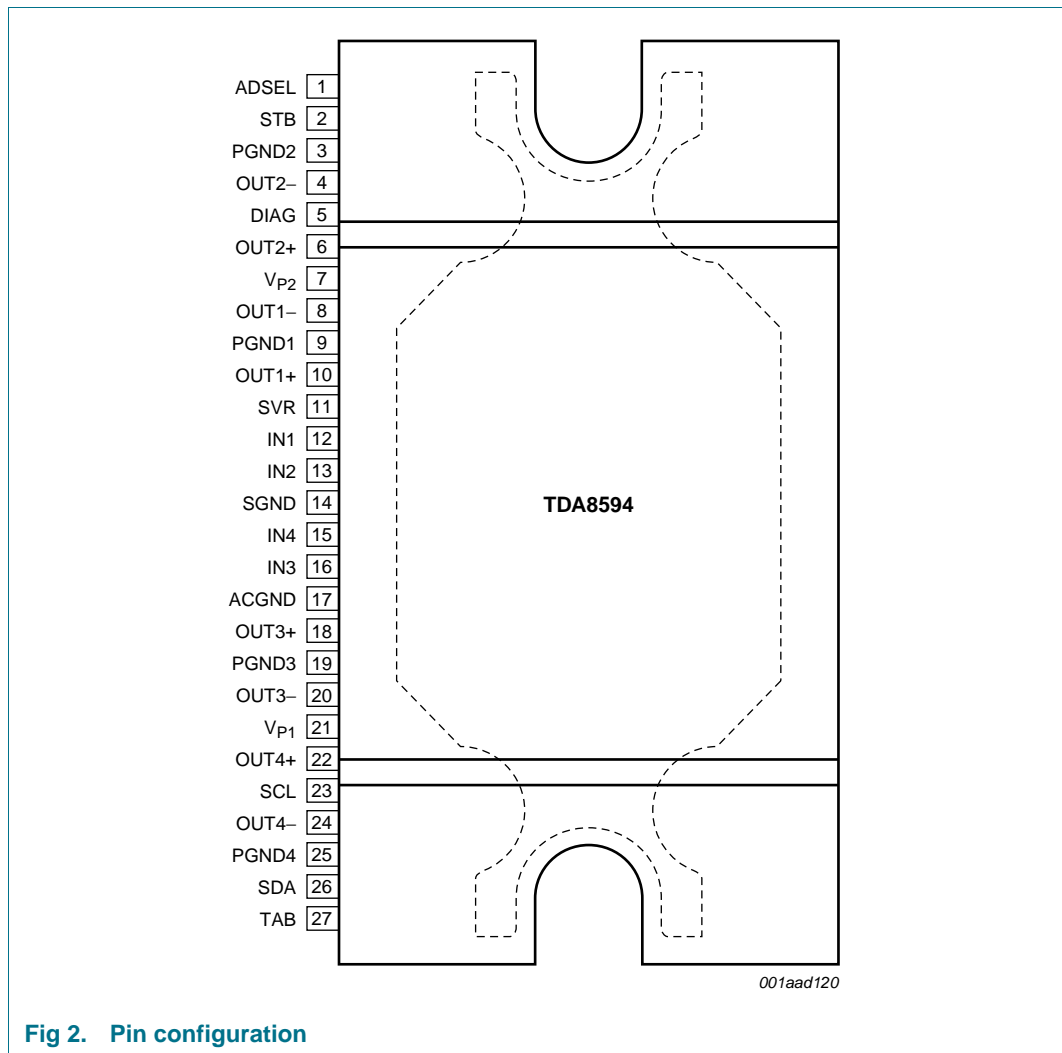

Fig 2. Pin configuration

### 6.2 Pin description

Table 3. Pin description

Symbol	Pin	Description
ADSEL	1	I <sup>2</sup> C-bus address select input
STB	2	standby (I <sup>2</sup> C-bus mode) or mode pin (legacy mode); programmable second clip indicator
PGND2	3	power ground channel 2
OUT2-	4	negative channel 2 output
DIAG	5	diagnostic/clip detection output
OUT2+	6	positive channel 2 output
V <sub>P2</sub>	7	supply voltage 2

**Table 3.** Pin description ...continued

Symbol	Pin	Description
OUT1-	8	negative channel 1 output
PGND1	9	power ground channel 1
OUT1+	10	positive channel 1 output
SVR	11	half supply filter capacitor
IN1	12	channel 1 input
IN2	13	channel 2 input
SGND	14	signal ground
IN4	15	channel 4 input
IN3	16	channel 3 input
ACGND	17	AC ground input
OUT3+	18	positive channel 3 output
PGND3	19	power ground channel 3
OUT3-	20	negative channel 3 output
V <sub>P1</sub>	21	supply voltage 1
OUT4+	22	positive channel 4 output
SCL	23	I <sup>2</sup> C-bus clock input
OUT4-	24	negative channel 4 output
PGND4	25	power ground channel 4
SDA	26	I <sup>2</sup> C-bus data input/output
TAB	27	heatsink connection, must be connected to ground

To keep the output pins on the front side, special reverse bending is applied.

## 7. Functional description

The TDA8594 is a complementary quad BTL audio power amplifier made in BCDMOS technology. It contains four independent amplifiers in BTL configuration (see [Figure 1](#)). Through the I<sup>2</sup>C-bus, the diagnostic functions of temperature level and clip level are fully programmable and the information to be shown on the two diagnostic pins can be selected. The status of each amplifier (output offset, load or no load, short-circuit or speaker incorrectly connected) can be read separately. The TDA8594 is protected against overvoltage, short-circuit, over-temperature, open ground and open V<sub>P</sub> connections.

Three different I<sup>2</sup>C-bus addresses are selected with an external resistor connected to the ADSEL pin. If the ADSEL pin is short-circuit to ground, the TDA8594 operates in legacy mode. In this mode, no I<sup>2</sup>C-bus is needed and the function of the STB pin will change from two-level (Standby mode and On mode) to a three-level pin (Standby mode, On mode and mute).

### 7.1 Input stage

The input stage is a high-impedance pseudo-differential input stage. The negative inputs of the four channels are combined on the ACGND pin. For the best performance on supply voltage ripple rejection and pop noise, the capacitor connected to the ACGND pin must be four times the value of the input capacitor (or as close to the value as possible).

## 7.2 Output stage

The output stage of each amplifier channel consists of two PMOS power transistors and two NMOS transistors in a BTL configuration. The process used is the BCDMOS process with an isolated substrate, Silicon On Insulator (SOI) process, which has almost no parasitic components and therefore prevents latch-up.

## 7.3 Distortion (clip) detection

If the output of the amplifier starts clipping to the supply voltage or to ground, the output will become distorted. If the distortion per channel exceeds a selectable threshold (2 %, 5 % or 10 %), one of the two diagnostic pins (DIAG pin or STB pin) will be activated. To be able to detect if, for instance, the front channels (channel 1 and channel 3) or rear channels (channel 2 and channel 4) are clipping, the clip information can be directed per channel to the DIAG pin or the STB pin. It is possible to have only the clip information on the diagnostic pins by disabling the temperature and load information on the DIAG pin. In this mode the temperature and load protection are still functional but can only be read via the I<sup>2</sup>C-bus.

## 7.4 Output protection and short-circuit operation

When a short-circuit to ground,  $V_P$  or across the load occurs on one or more outputs of an amplifier, only the amplifier with the short-circuit is switched off. The channel that has a short-circuit and the type of short-circuit can be read-back via the I<sup>2</sup>C-bus. If the DIAG pin is enabled for load fault information (IB2[D4] = 0) the DIAG pin will be pulled LOW. After 16 ms the amplifier will be switched on again and, if the short-circuit conditions still occur, the amplifier will be switched off.

The 16 ms cycle will reduce the dissipation. To prevent audible distortion, the amplifier channel with the short-circuit can be disabled via the I<sup>2</sup>C-bus.

## 7.5 SOAR protection

The output transistors are protected by Safe Operating ARea (SOAR) protection. The TDA8594 has a two-stage SOAR protection:

- If the differential output voltage across the load is less than 1 V, and the current through the load is more than 4 A, the amplifier channel will be switched off for 16 ms. To prevent incorrect switch-off with an inductive load or very high input signals, the condition ( $V_o < 1$  V and  $I_L > 4$  A) must exist for more than 300  $\mu$ s.
- If the differential output voltage across the load is more than 1 V, and the current through the load is more than 8 A, the amplifier channel will be switched off for 16 ms.

## 7.6 Speaker protection

To prevent damage of the speaker when one side of the speaker is connected to ground, a missing current protection is implemented. When in one channel the current in the high side power is not equal to the current in the low side power, a fault condition is assumed and the channel will be switched off. The speaker protection will be activated under the following conditions:

- $V_o < 1.75$  V and  $I_{\text{missing(det)}} > 1$  A for 80  $\mu$ s
- $V_o > 1.75$  V and  $I_{\text{missing(det)}} > 3$  A for 80  $\mu$ s

## 7.7 Standby and mute operation

The function of the STB pin is different in legacy mode and I<sup>2</sup>C-bus mode.

### 7.7.1 Legacy mode (pin ADSEL connected to ground)

The function of the STB pin will change from standby/operating to standby/mute/operating and the amplifier will start directly when the STB is put into mute or operating mode. Mute operating is controlled via an internal timer (20 ms) to minimize mute-on pops. When the STB pin is switched directly from operating to standby, first the fast mute will be activated (switching to mute within 100 μs) and then the amplifier will shut-down.

### 7.7.2 I<sup>2</sup>C-bus mode

When the STB pin is LOW, the total quiescent current is low, and the I<sup>2</sup>C-bus lines will not be loaded.

When the STB pin is switched HIGH, the TDA8594 is put in operating condition and will perform a Power-On Reset (POR), which results in a LOW level DIAG pin. The TDA8594 will start up when instruction bit IB1[D0] is set. Bit D0 will also reset the 'power-on reset occurred' bit (DB2[D7]) and releases the DIAG pin.

The soft mute and fast mute can be activated via the I<sup>2</sup>C-bus. The soft mute can be activated independently for the front channels (channel 1 and channel 3) and rear channels (channel 2 and channel 4), and mutes the audio in 20 ms. The fast mute activates the mute for all channels at the same time and mutes the audio in 0.1 ms. Releasing the mute after a fast mute will be by a soft un-mute of approximately 20 ms.

When the STB pin is switched to Standby mode and the amplifier has started, first the fast mute will be activated and then the amplifier will shut-down. For instance, during an engine start, it is possible to fully mute the amplifiers within 100 μs by switching the STB pin to zero.

## 7.8 Start-up and shut-down sequence

To prevent the amplifier producing switch-on or switch-off pop noise, the capacitor on the SVR pin is used for smooth start-up and shut-down. Increasing the value of the SVR capacitor will mean a longer start-up and shut-down time. The amplifier output voltage is charged to half the supply voltage minus 1.4 V in mute condition, independent of the I<sup>2</sup>C-bus mute settings in I<sup>2</sup>C-bus mode or STB voltage in legacy mode. The last 1.4 V, where the output will reach half the supply voltage, is used to release the mute if the I<sup>2</sup>C-bus bits were set to mute off (IB2[D2:D0] = 000; V<sub>STB</sub> > 6.5 V in legacy mode), or will stay in mute when the bits were set to mute (2.6 V < V<sub>STB</sub> < 4.5 V in legacy mode).

When the amplifier is switched off by pulling the STB pin LOW, the amplifier is first muted (fast mute) and then the capacitor on the SVR pin is discharged. With an SVR capacitor of 22 μF, the standby current has reached 1 second after the STB pin is switched to zero (see [Figure 3](#), [Figure 4](#), [Figure 5](#) and [Figure 6](#)).

The start-up and shut-down pop can be further decreased by activating the low pop mode. When the low pop mode is enabled (IB2[D3] = 0), the output voltage rise from ground level during start-up will be slower (see [Figure 5](#)). This will decrease the pop even more but will increase the start-up time.

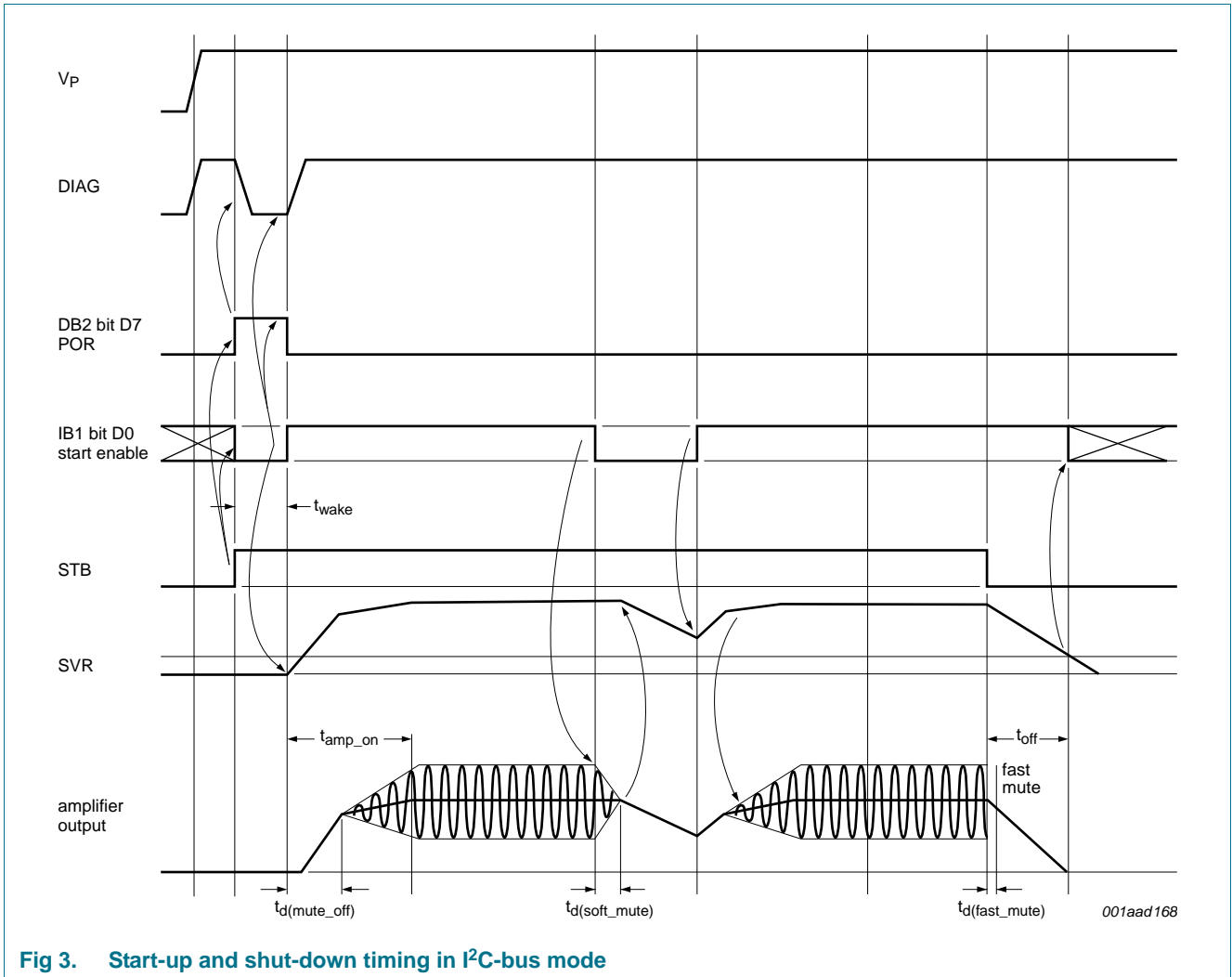

Fig 3. Start-up and shut-down timing in I<sup>2</sup>C-bus mode



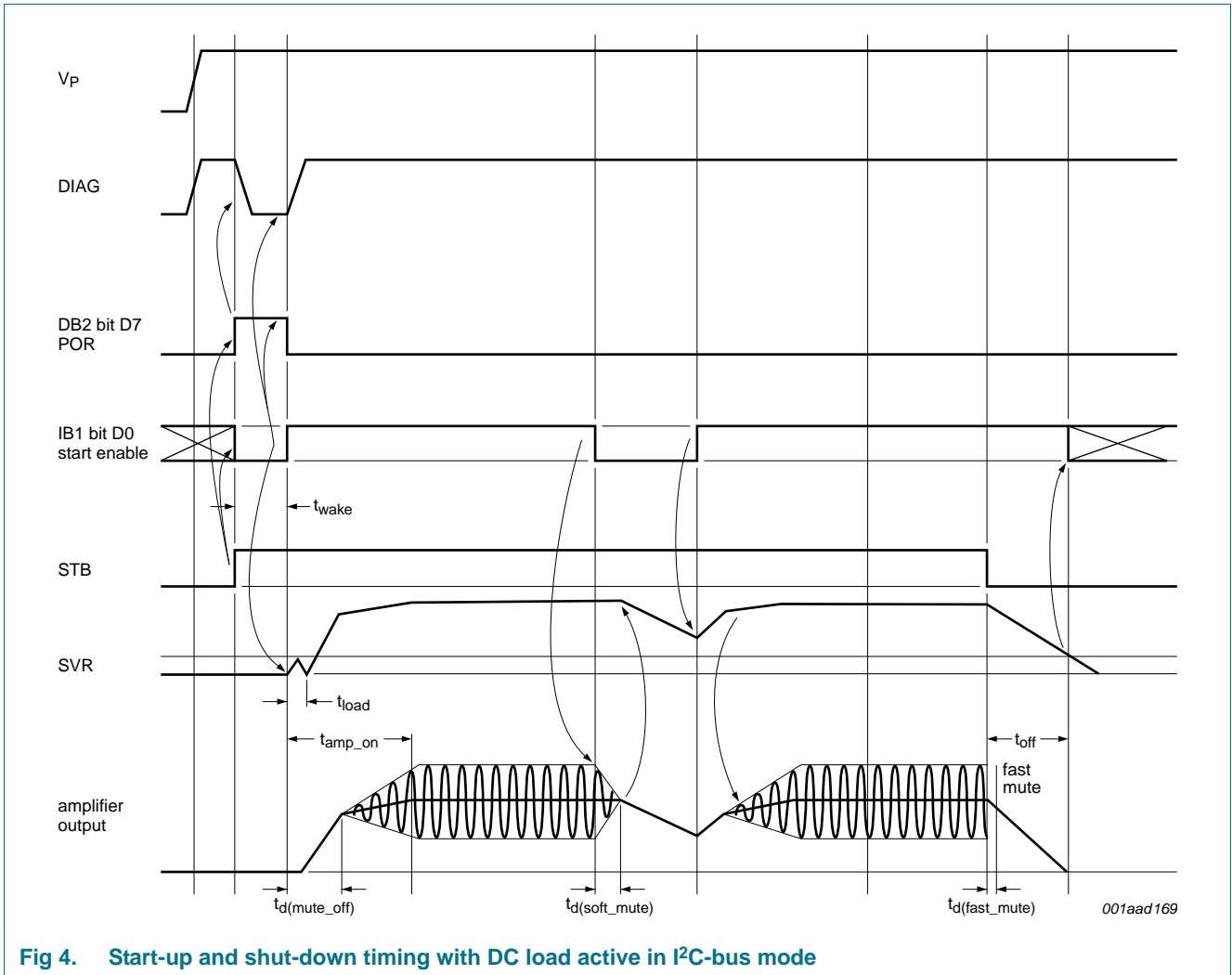

Fig 4. Start-up and shut-down timing with DC load active in I<sup>2</sup>C-bus mode

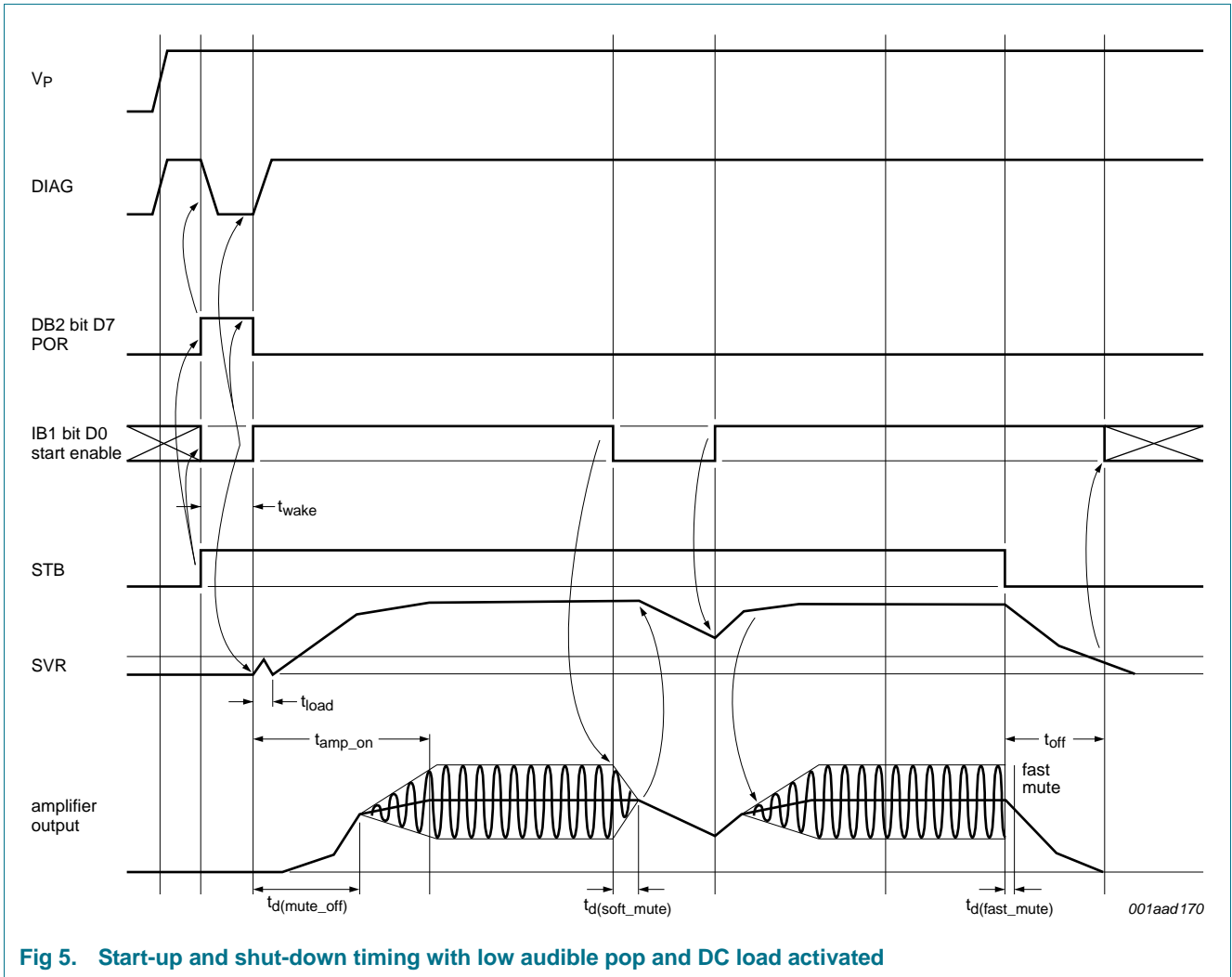

Fig 5. Start-up and shut-down timing with low audible pop and DC load activated

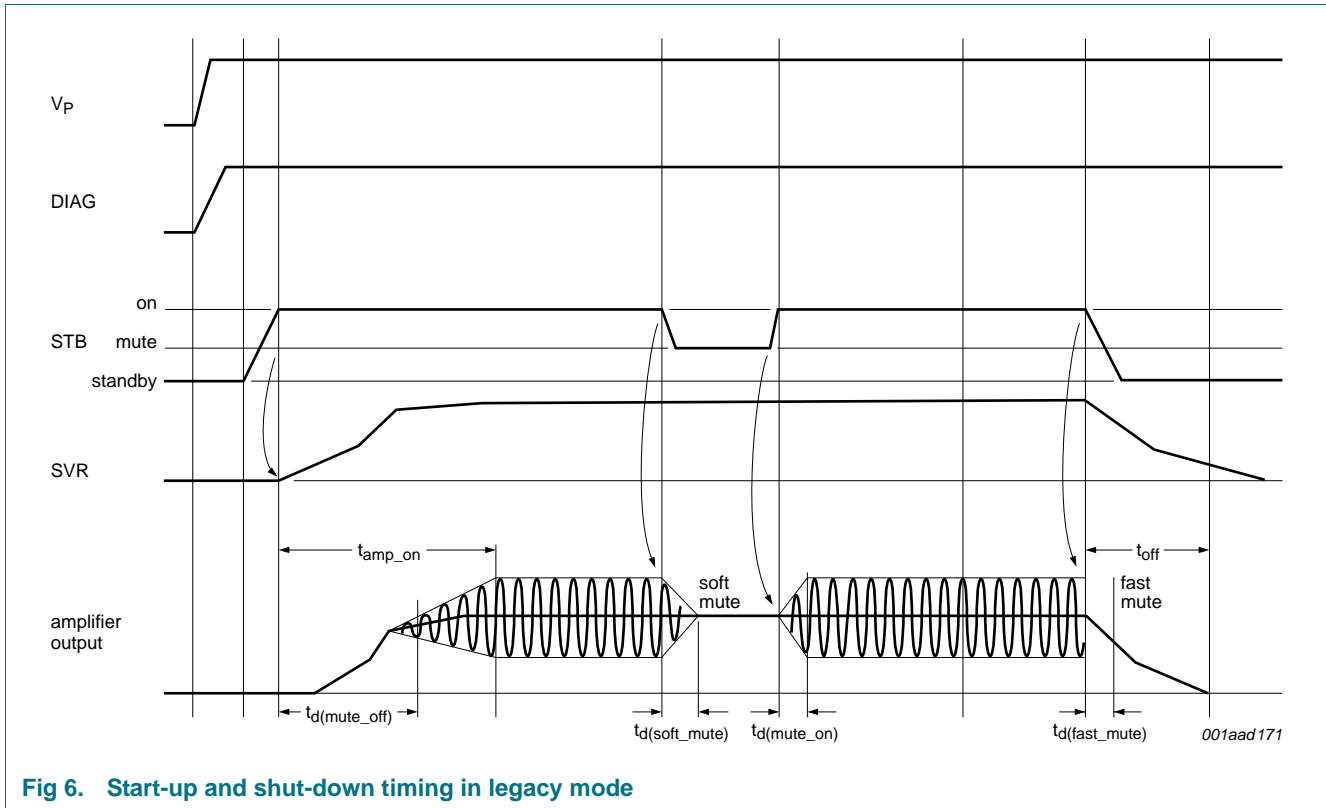

Fig 6. Start-up and shut-down timing in legacy mode

### 7.9 Power-on reset and supply voltage spikes

If in I<sup>2</sup>C-bus mode the supply voltage drops below 5 V (see Figure 9), the content of the I<sup>2</sup>C-bus latches cannot be guaranteed and the power-on reset will be activated. All latches are reset, the amplifier is switched off and the DIAG pin is pulled LOW to indicate that a power-on reset has occurred (bit DB2[D7]). When IB1[D0] is set, the power-on flag is reset, the DIAG pin will be released and the amplifier will start up.

In legacy mode a supply voltage drop below 5 V will switch off the amplifier and the DIAG pin will not be pulled LOW.

### 7.10 Engine start and low voltage operation

The DC output voltage of the amplifier (V<sub>O</sub>) is set to half of the supply voltage and is related to the voltage on the SVR pin (see Figure 7; V<sub>O</sub> = V<sub>SVR</sub> - 1.4 V). A capacitor is connected on the SVR pin to suppress the ripple on the power supply.

If the supply voltage drops, for instance, during an engine start, the output follows slowly due to the SVR capacitor. The headroom voltage is the voltage needed for good operation of the amplifier and is defined as V<sub>hr</sub> = V<sub>P</sub> - V<sub>O</sub> (see Figure 7). If the headroom voltage becomes lower than the headroom protection threshold of 1.6 V, the headroom protection is activated to prevent pop noise at the output. This protection first activates the fast mute and then discharges the capacitors on the SVR and ACGND pins to generate more headroom for the amplifier (see Figure 8).

When the SVR capacitor has discharged, the amplifier starts up again if the  $V_P$  voltage is above the low  $V_P$  mute threshold, typically 7.5 V. Below the low  $V_P$  mute threshold, the outputs of the amplifier remain low. In I<sup>2</sup>C-bus mode, a supply voltage drop below  $V_{P(reset)}$ , typically 5 V, results in setting bit DB2[D7] and not starting of the amplifiers but waiting for an I<sup>2</sup>C-bus command to start.

The amplifier prevents audio pops during engine start. To prevent pops on the output caused by the application during an engine start (for instance tuner regulator out of regulation), the STB pin can be made zero when an engine start is detected. The STB pin activates the fast mute and disturbances at the amplifier inputs are suppressed.

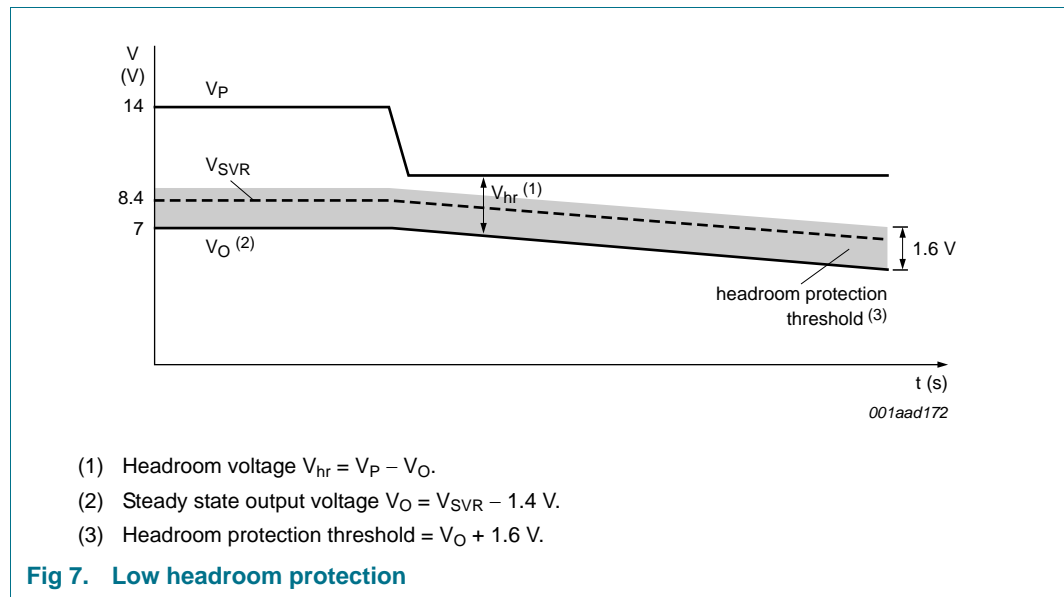

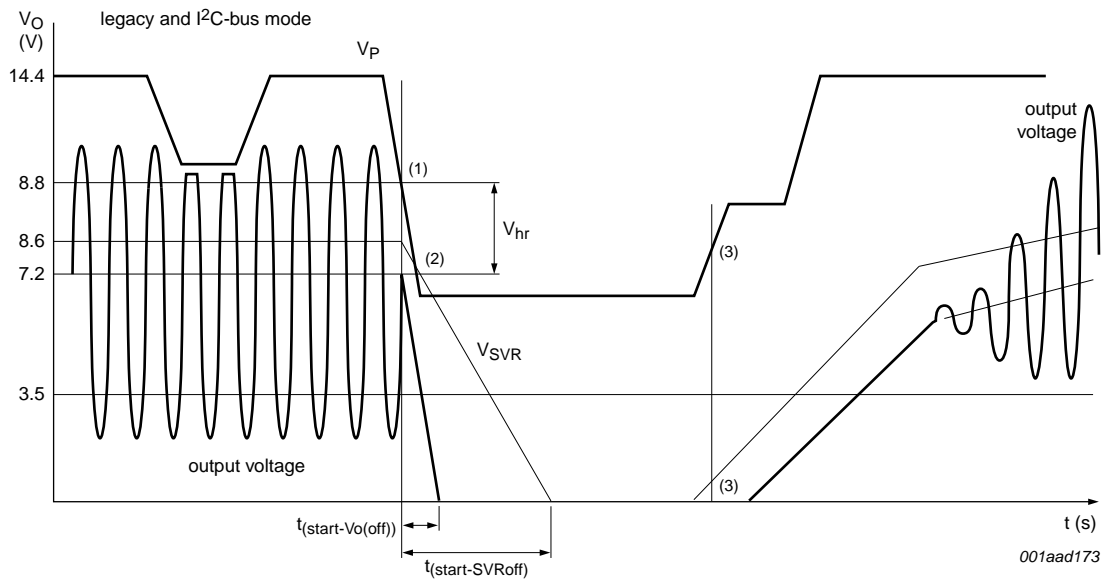

- (1) Headroom protection activated:
  - a) Fast mute
  - b) Discharge of SVR.
- (2) Low  $V_P$  mute activated.
- (3) Low  $V_P$  mute released.

**Fig 8. Low  $V_P$  behavior; legacy and I<sup>2</sup>C-bus modes**

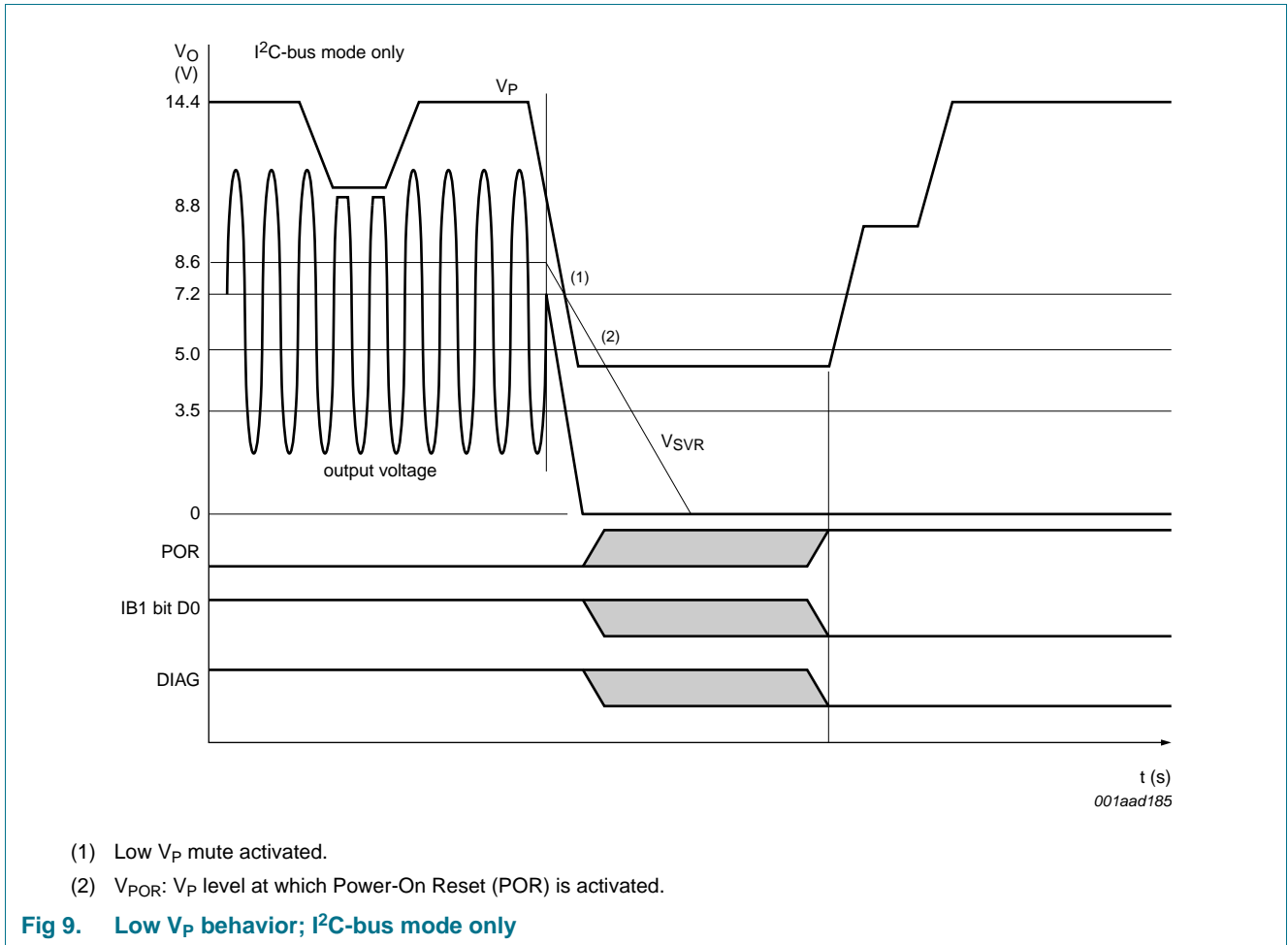

### 7.11 Overvoltage and load dump protection

When the battery voltage  $V_P$  is higher than 22 V, the amplifier stage will be switched to high-impedance. The TDA8594 is protected against load dump voltage with supply voltage up to 50 V.

### 7.12 Thermal pre-warning and thermal protection

If the average junction temperature reaches a level that is adjustable via the I<sup>2</sup>C-bus, selected with IB3[D4], the pre-warning will be activated resulting in a LOW level on pin DIAG (if selected) and can be read out via the I<sup>2</sup>C-bus. The default setting for the thermal pre-warning is IB3[D4] = 0 setting the warning level at 145 °C. In legacy mode the thermal pre-warning is set at 145 °C.

If the temperature increases further, the temperature controlled gain reduction will be activated for all four channels to reduce the output power (see Figure 10). If this does not reduce the average junction temperature, all four channels will be switched off at the absolute maximum temperature  $T_{off}$ , typical 175 °C.

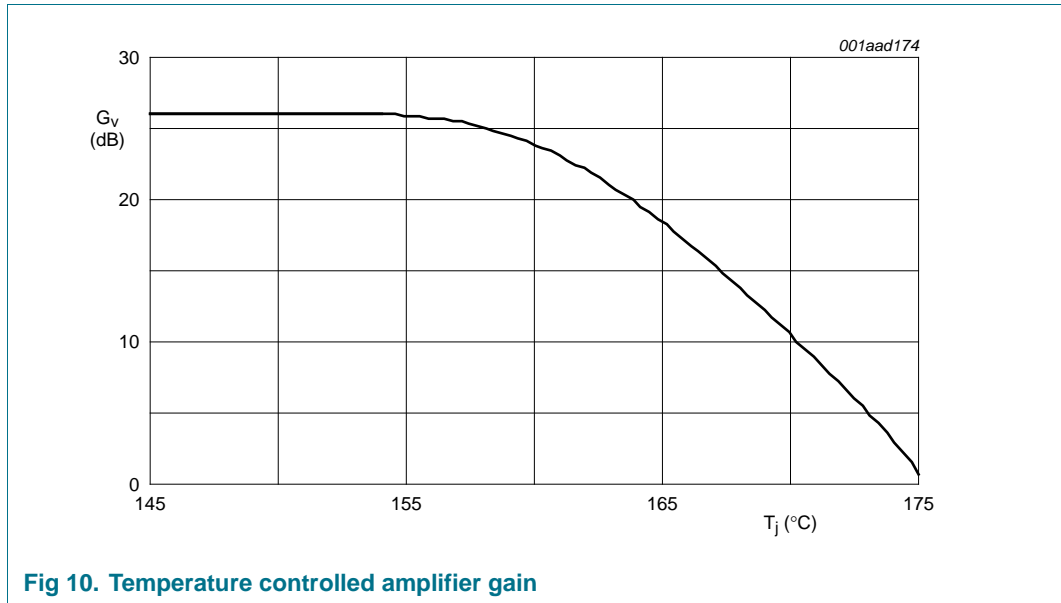

Fig 10. Temperature controlled amplifier gain

### 7.13 Diagnostics

Diagnostic information can be read via the I<sup>2</sup>C-bus, and can also be available on the DIAG pin or on the STB pin. The DIAG pin has both fixed information (power-on reset occurred, low battery and high battery) and, via the I<sup>2</sup>C-bus, selectable information (temperature, load fault and clip). This information will be seen at the DIAG pin as a logic OR. In case of a failure, the DIAG pin remains LOW and the failure information can be read from the microprocessor via the I<sup>2</sup>C-bus (the DIAG pin can be used as a microprocessor interrupt to minimize I<sup>2</sup>C-bus traffic). When the failure is removed, the DIAG pin will be released.

To have full control over the clipping information, the STB pin can be programmed as a second clip detection pin. The clip detection level can be selected for all channels at once. It is possible to select whether the clip information is available on the DIAG pin or on the STB pin for each channel separately. It is, for instance, possible to distinguish between clipping of the front and the rear channels.

Diagnostic information selection possibilities are shown in [Table 4](#).

Table 4. Diagnostic information availability

Diagnostic information	I <sup>2</sup> C-bus mode		Legacy mode
	DIAG pin	STB pin	DIAG pin
POR	after power-on reset, DIAG pin will remain LOW until amplifier has been started	no	no
Low battery	yes	no	yes
Clip detection	can be enabled per channel	can be enabled per channel	yes, fixed level for all channels on 2 %
Temperature pre-warning	can be enabled	no	yes, pre-warning level is 145 °C
Short	can be enabled	no	yes
Speaker protection (missing current)	can be enabled	no	yes

Table 4. Diagnostic information availability ...continued

Diagnostic information	I <sup>2</sup> C-bus mode		Legacy mode
	DIAG pin	STB pin	DIAG pin
Offset detection	no	no	no
Load detection	no	no	no
Overvoltage	yes	no	yes

### 7.14 Offset detection

The offset detection can be performed with no input signal (for instance when the digital signal processor is in mute after a start-up) or with an input signal. In I<sup>2</sup>C-bus mode, if an I<sup>2</sup>C-bus read of the output offset is performed, the I<sup>2</sup>C-bus latches DBx[D2] will be set. When the amplifier BTL output voltage is within a window with a threshold of 1.75 V typical, the latches DBx[D2] are reset and setting is disabled. If, for instance, after 1 second an I<sup>2</sup>C-bus read is performed again and the offset bits are still set, the output has not crossed the offset threshold during the last 1 second (see Figure 11). This can mean the applied frequency is below 1 Hz (I<sup>2</sup>C-bus read interval = 1 s) or an output offset of more than 1.75 V is present.

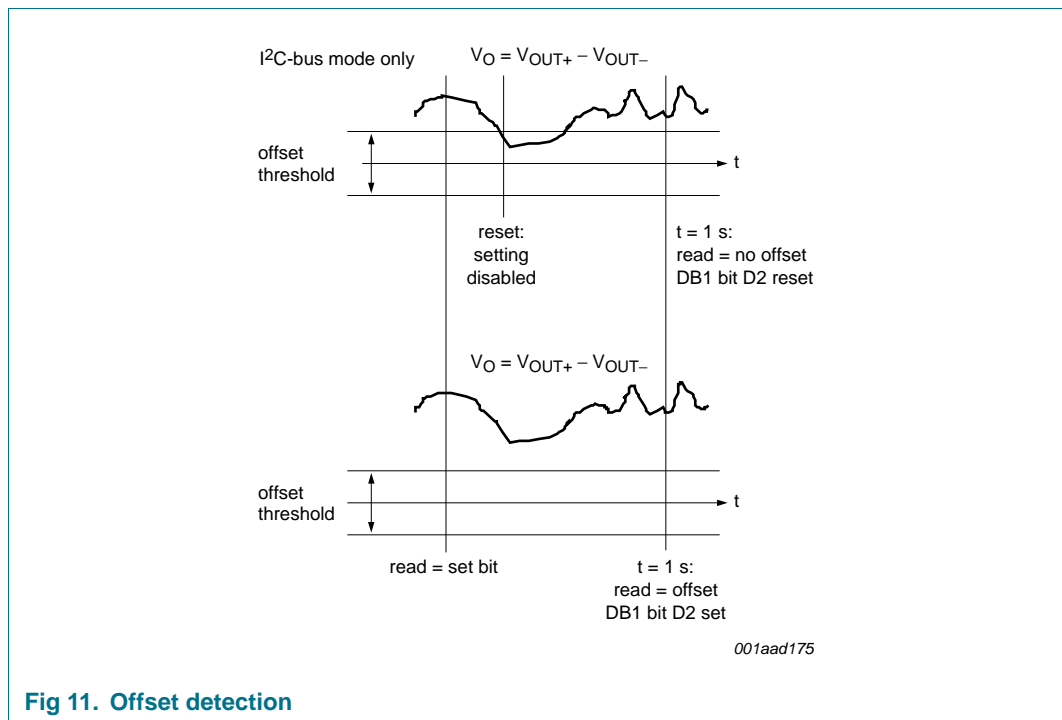
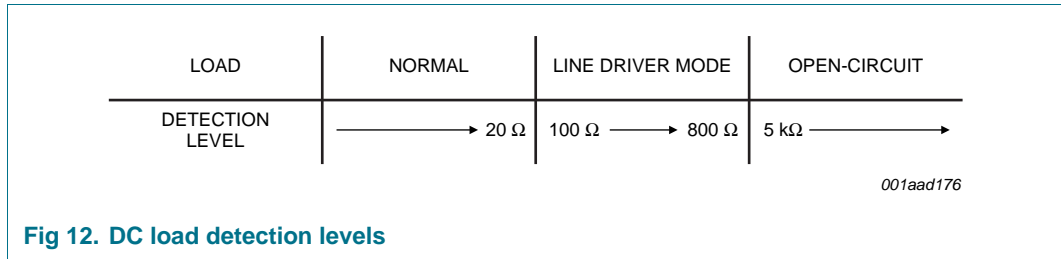

Fig 11. Offset detection

### 7.15 DC load detection

When the DC load detection is enabled with IB1[D1], a DC offset is slowly applied at the output of the amplifiers during the start-up cycle and the load currents are measured. Different load levels will be detected to differentiate between normal load, line driver load or open load.





If the amplifier is used as line driver and the external booster has an input impedance of more than 100 Ω and less than 800 Ω (DC-coupled), the DC load bits will contain DBx[D5:D4] = 10, independent of the gain setting (see Table 5).

Table 5. DC load detection

DC load bits		Meaning (when IB1[D2] = 0)
DBx[D5]	DBx[D4]	
0	0	normal load
1	0	line driver load
1	1	open load
0	1	not valid

By reading the I<sup>2</sup>C-bus bits the microprocessor can determine, after the start-up of the amplifier, whether a speaker or an external booster is connected.

Depending on these bits, the amplifier gain can be selected, 26 dB for normal mode or 16 dB for line driver mode. If the gain select is performed when the amplifier is muted, the gain select will be pop free.

The DC load bits are combined with the AC load bits and are only valid when the AC load detection is disabled. When the AC load detection is enabled (IB1[D2] = 1), the bits DBx[D4] will show the content of the AC load detection. When the AC load detection is disabled again, bit DBx[D4] will show the content of the DC load measurement, which was stored during the AC load measurement. The AC load detection can only be performed after the amplifier has completed its start-up cycle and will not conflict with the DC load detection.

### 7.16 AC load detection

The AC load detection, enabled with IB1[D2] = 1, is used to detect if AC-coupled speakers, for example tweeters, are connected correctly during assembly. The detection is audible because a sine wave of a certain frequency (e.g. 19 kHz) needs to be applied to the inputs of the amplifier. The output voltage over the load impedance will generate an amplifier current. If the amplifier peak current triggers a 460 mA (peak) threshold detector three times, the AC load detection bit will be set. A three ‘threshold cross’ counter is used to prevent false AC load detection when switching the input signal on or off.

An AC-coupled speaker will reduce the impedance at the output of the amplifier in a certain frequency band. The presence of an AC-coupled speaker can be determined using 460 mA (peak) and 230 mA (peak) threshold current detection. For instance, at an output voltage of 2 V (peak) the total impedance must be less than 4 Ω to detect the AC-coupled load, or more than 8 Ω to guarantee only a DC connection is detected.

The interpretation of line driver and normal mode DC load bit settings for AC load detection is shown in [Table 6](#).

**Table 6. AC load detection**

DBx[D4]	Meaning (when IB1[D2] = 1)
0	no AC load detected
1	AC load detected

When bit IB1[D2] = 1, the AC load detection is enabled. The AC load detection can only be performed after the amplifier has completed its start-up cycle and will not conflict with the DC load detection.

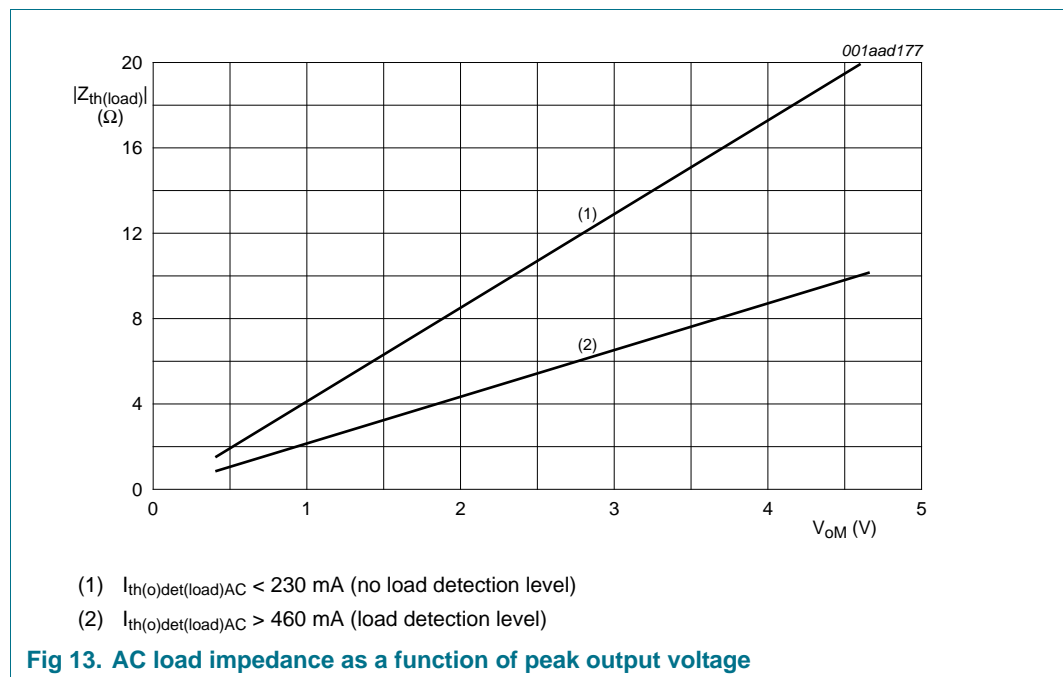

### 7.17 I<sup>2</sup>C-bus diagnostic readout

The diagnostic information of the amplifier can be read via the I<sup>2</sup>C-bus. The I<sup>2</sup>C-bus bits are set on a failure and will be reset with the I<sup>2</sup>C-bus read command. Even when the failure is removed, the microprocessor will know what was wrong by reading the I<sup>2</sup>C-bus. The consequence of this procedure is that old information is read during the I<sup>2</sup>C-bus readout. Most actual information will be gathered after two successive read commands.

The DIAG pin will give actual diagnostic information (when selected). When a failure is removed, the DIAG pin will be released instantly, independently of the I<sup>2</sup>C-bus latches.

## 8. I<sup>2</sup>C-bus specification

Table 7. TDA8594 hardware address select

Pin ADSEL	A6	A5	A4	A3	A2	A1	A0	R/W
Open	1	1	0	1	1	0	0	0 = write to TDA8594 1 = read from TDA8594
51 kΩ to ground	1	1	0	1	1	0	1	0 = write to TDA8594 1 = read from TDA8594
10 kΩ to ground	1	1	0	1	1	1	1	0 = write to TDA8594 1 = read from TDA8594
Ground	no I <sup>2</sup> C-bus; legacy mode							

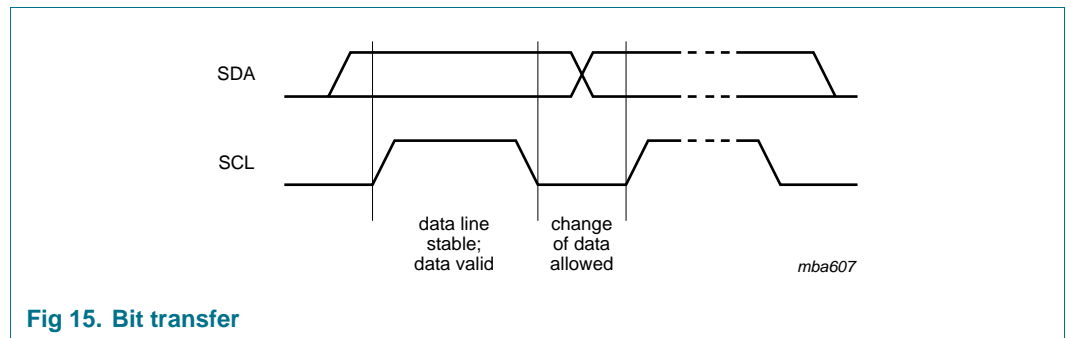
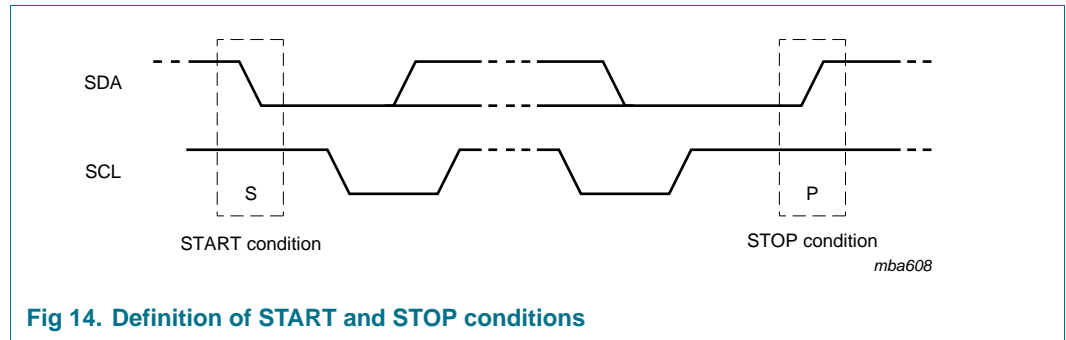

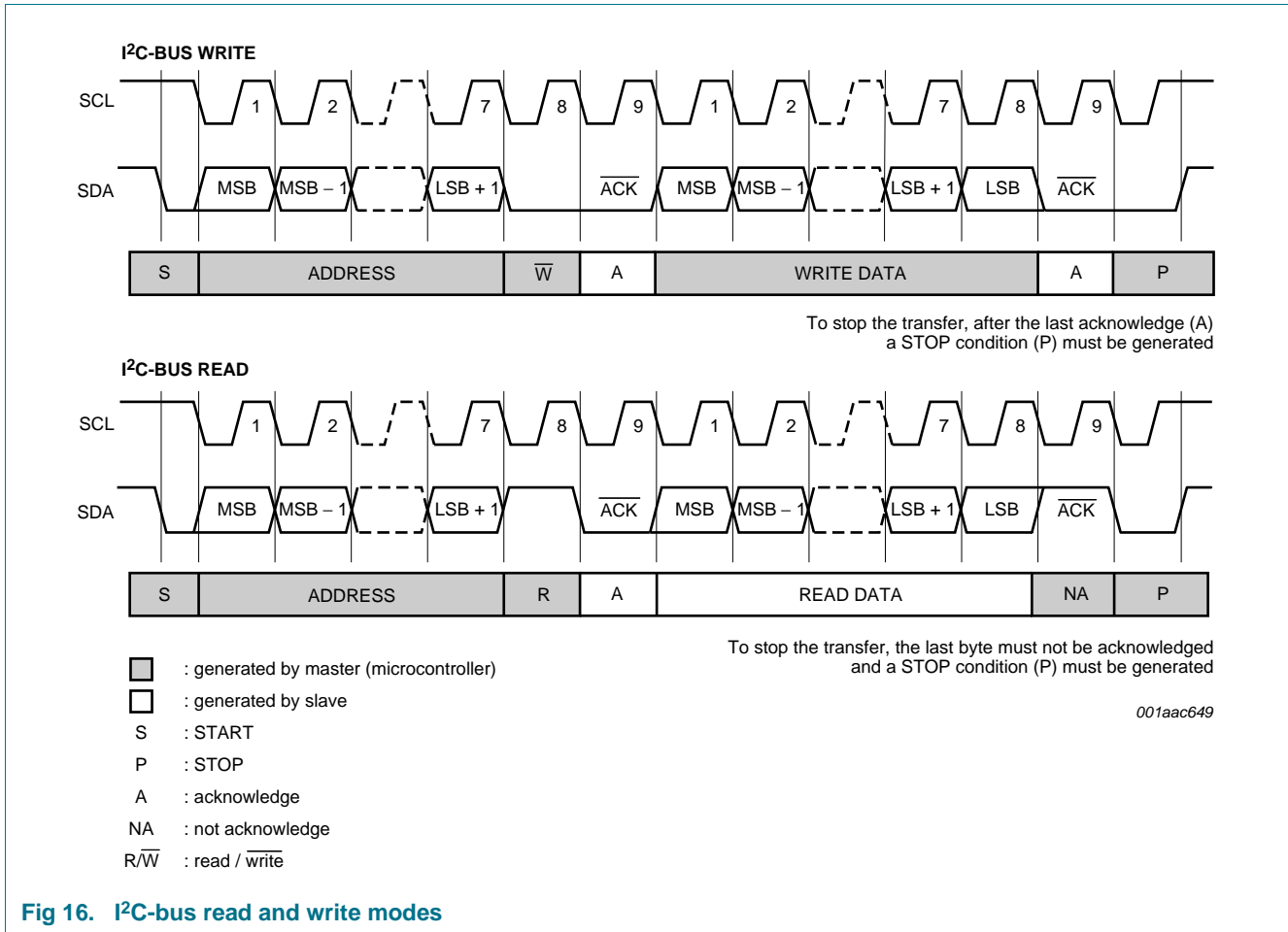

### 8.1 Instruction bytes

I<sup>2</sup>C-bus mode:

- If bit R/ $\overline{\text{W}}$  = 0, the TDA8594 expects three instruction bytes; IB1, IB2 and IB3
- After a power-on reset, all instruction bits are set to zero.

Legacy mode:

- All bits equal to zero define the setting, with the exception of bit IB1[D0] which is ignored; see [Table 8](#).

**Table 8. Instruction byte IB1**

Bit	Description
D7	don't care
D6	channel 3 clip information on DIAG or STB pin 0 = clip information on DIAG pin 1 = clip information on STB pin
D5	channel 1 clip information on DIAG or STB pin 0 = clip information on DIAG pin 1 = clip information on STB pin

**Table 8. Instruction byte IB1 ...continued**

Bit	Description
D4	channel 4 clip information on DIAG or STB pin 0 = clip information on DIAG pin 1 = clip information on STB pin
D3	channel 2 clip information on DIAG or STB pin 0 = clip information on DIAG pin 1 = clip information on STB pin
D2	AC load detection enable 0 = AC load detection disabled 1 = AC load detection enabled; DBx[D4] bits not available for DC load detection
D1	DC load detection enable 0 = DC load detection disabled 1 = DC load detection enabled
D0	amplifier start enable 0 = amplifier not enabled, DIAG pin will remain LOW 1 = amplifier will start up, power-on occurred (DB2[D7] will be reset) and DIAG pin will be released

**Table 9. Instruction byte IB2**

Bit	Description
D7 and D6	clip detection level 00 = clip detection level 2 % 01 = clip detection level 5 % 10 = clip detection level 10 % 11 = clip detection level disabled
D5	temperature information on DIAG pin 0 = temperature information on DIAG pin 1 = no temperature information on DIAG pin
D4	load fault information (shorts, missing current) on DIAG pin 0 = fault information on DIAG pin 1 = no fault information on DIAG pin
D3	low pop (slow start) enable 0 = low pop enabled 1 = low pop disabled
D2	soft mute channel 1 and channel 3 (mute delay 20 ms) 0 = no mute 1 = mute
D1	soft mute channel 2 and channel 4 (mute delay 20 ms) 0 = no mute 1 = mute

Table 9. Instruction byte IB2 ...continued

Bit	Description
D0	fast mute all amplifier channels (mute delay 100 μs)
	0 = no mute
	1 = mute

Table 10. Instruction byte IB3

Bit	Description
D7	don't care
D6	amplifier channel 1 and channel 3 gain select
	0 = 26 dB
	1 = 16 dB
D5	amplifier channel 2 and channel 4 gain select
	0 = 26 dB
	1 = 16 dB
D4	temperature pre-warning level
	0 = warning level on 145 °C
	1 = warning level on 122 °C
D3	disable channel 3
	0 = channel 3 enabled
	1 = channel 3 disabled
D2	disable channel 1
	0 = channel 1 enabled
	1 = channel 1 disabled
D1	disable channel 4
	0 = channel 4 enabled
	1 = channel 4 disabled
D0	disable channel 2
	0 = channel 2 enabled
	1 = channel 2 disabled

## 8.2 Data bytes

I<sup>2</sup>C-bus mode:

- If bit  $\overline{R/\overline{W}} = 1$ , the TDA8594 sends four data bytes to the microprocessor: DB1, DB2, DB3, and DB4
- All bits except DB1[D7] and DB3[D7] are latched.
- All bits except DBx[D4] and DBx[D5] are reset after a read operation. Bit DBx[D2] is set after a read operation; see [Section 7.14](#)
- For explanation of AC and DC load detection bits; see [Section 7.15](#) and [Section 7.16](#).

Table 11. Data byte DB1

Bit	Description
D7	temperature pre-warning 0 = no warning 1 = junction temperature too high
D6	speaker fault channel 2 (missing current) 0 = no missing current 1 = missing current
D5 and D4	channel 2 DC load or AC load detection if bit IB1[D2] = 1, AC load detection is enabled, bit D5 is don't care, bit D4 has the following meaning 0 = no AC load 1 = AC load detected if bit IB1[D2] = 0, AC load detection is disabled, bits D5 and D4 are available for DC load detection 00 = normal load 01 = not valid 10 = line driver load 11 = open load
D3	channel 2 shorted load 0 = not shorted load 1 = shorted load
D2	channel 2 output offset 0 = no output offset 1 = output offset
D1	channel 2 short to V <sub>P</sub> 0 = no short to V <sub>P</sub> 1 = short to V <sub>P</sub>
D0	channel 2 short to ground 0 = no short to ground 1 = short to ground

Table 12. Data byte DB2

Bit	Description
D7	power-on reset and amplifier status 0 = amplifier on 1 = power-on reset has occurred; amplifier off
D6	speaker fault channel 4 (missing current) 0 = no missing current 1 = missing current

Table 12. Data byte DB2 ...continued

Bit	Description
D5 and D4	channel 4 DC load or AC load detection if bit IB1[D2] = 1, AC load detection is enabled, bit D5 is don't care, bit D4 has the following meaning 0 = no AC load 1 = AC load detected if bit IB1[D2] = 0, AC load detection is disabled, bits D5 and D4 are available for DC load detection 00 = normal load 01 = not valid 10 = line driver load 11 = open load
D3	channel 4 shorted load 0 = not shorted load 1 = shorted load
D2	channel 4 output offset 0 = no output offset 1 = output offset
D1	channel 4 short to V <sub>P</sub> 0 = no short to V <sub>P</sub> 1 = short to V <sub>P</sub>
D0	channel 4 short to ground 0 = no short to ground 1 = short to ground

Table 13. Data byte DB3

Bit	Description
D7	maximum temperature protection 0 = no protection 1 = maximum temperature protection
D6	speaker fault channel 1 (missing current) 0 = no missing current 1 = missing current



Table 13. Data byte DB3 ...continued

Bit	Description
D5 and D4	channel 1 DC load or AC load detection if bit IB1[D2] = 1, AC load detection is enabled, bit D5 is don't care, bit D4 has the following meaning 0 = no AC load 1 = AC load detected if bit IB1[D2] = 0, AC load detection is disabled, bits D5 and D4 are available for DC load detection 00 = normal load 01 = not valid 10 = line driver load 11 = open load
D3	channel 1 shorted load 0 = not shorted load 1 = shorted load
D2	channel 1 output offset 0 = no output offset 1 = output offset
D1	channel 1 short to V <sub>P</sub> 0 = no short to V <sub>P</sub> 1 = short to V <sub>P</sub>
D0	channel 1 short to ground 0 = no short to ground 1 = short to ground

Table 14. Data byte DB4

Bit	Description
D7	reserved
D6	speaker fault channel 3 (missing current) 0 = no missing current 1 = missing current
D5 and D4	channel 3 DC load or AC load detection if bit IB1[D2] = 1, AC load detection is enabled, bit D5 is don't care, bit D4 has the following meaning 0 = no AC load 1 = AC load detected if bit IB1[D2] = 0, AC load detection is disabled, bits D5 and D4 are available for DC load detection 00 = normal load 01 = not valid 10 = line driver load 11 = open load

Table 14. Data byte DB4 ...continued

Bit	Description
D3	channel 3 shorted load
	0 = not shorted load
	1 = shorted load
D2	channel 3 output offset
	0 = no output offset
	1 = output offset
D1	channel 3 short to V <sub>P</sub>
	0 = no short to V <sub>P</sub>
	1 = short to V <sub>P</sub>
D0	channel 3 short to ground
	0 = no short to ground
	1 = short to ground

## 9. Limiting values

Table 15. Limiting values

In accordance with the Absolute Maximum Rating System (IEC 60134).

Symbol	Parameter	Conditions	Min	Max	Unit
V <sub>P</sub>	supply voltage	operating	8	18	V
		non operating	-1	+50	V
		load dump protection; duration 50 ms, rise time > 2.5 ms	-	50	V
V <sub>P(r)</sub>	reverse supply voltage	t <sub>max</sub> = 10 minutes	-	-2	V
I <sub>OSM</sub>	non-repetitive peak output current		-	13	A
I <sub>ORM</sub>	repetitive peak output current		-	8	A
T <sub>j(max)</sub>	maximum junction temperature		-	150	°C
T <sub>stg</sub>	storage temperature		-55	+150	°C
T <sub>amb</sub>	ambient temperature		-40	+105	°C
V <sub>(prot)</sub>	protection voltage	AC and DC short-circuit of output pins and across the load	-	V <sub>P</sub>	V
V <sub>x</sub>	voltage on pin x	pins SCL and SDA	0	6.5	V
		pins IN1, IN2, IN3, IN4, SVR, ACGND and DIAG	0	13	V
		pin STB	0	24	V

**Table 15. Limiting values ...continued**

In accordance with the Absolute Maximum Rating System (IEC 60134).

Symbol	Parameter	Conditions	Min	Max	Unit
P <sub>tot</sub>	total power dissipation	T <sub>case</sub> = 70 °C	-	80	W
V <sub>esd</sub>	electrostatic discharge voltage	human body model; C = 100 pF; R <sub>S</sub> = 1.5 kΩ	-	2000	V
		machine model; C = 200 pF; R <sub>S</sub> = 10 Ω; L <sub>S</sub> = 0.75 μH	-	200	V

## 10. Thermal characteristics

**Table 16. Thermal characteristics**

Symbol	Parameter	Conditions	Typ	Unit
R <sub>th(j-c)</sub>	thermal resistance from junction to case		1	K/W
R <sub>th(j-a)</sub>	thermal resistance from junction to ambient	in free air	40	K/W

## 11. Characteristics

**Table 17. Characteristics**

Refer to [Figure 29](#) at V<sub>P</sub> = V<sub>P1</sub> = V<sub>P2</sub> = 14.4 V; R<sub>L</sub> = 4 Ω; f = 1 kHz; R<sub>S</sub> = 0 Ω; normal mode; unless otherwise specified. Tested at T<sub>amb</sub> = 25 °C; guaranteed for T<sub>amb</sub> = -40 °C to +105 °C.

Symbol	Parameter	Conditions	Min	Typ	Max	Unit
<b>Supply voltage behavior</b>						
V <sub>P</sub>	supply voltage	R <sub>L</sub> = 4 Ω	8	14.4	18	V
		R <sub>L</sub> = 2 Ω	<a href="#">1</a> 8	14.4	16	V
I <sub>q</sub>	quiescent current	no load	-	270	400	mA
I <sub>stb</sub>	standby current	V <sub>STB</sub> = 0.4 V	-	4	15	μA
V <sub>O</sub>	output voltage		6.7	7	7.2	V
V <sub>P(low)(mute)</sub>	low supply voltage mute	with rising supply voltage	6.9	7.5	8	V
		with falling supply voltage	6.3	6.8	7.4	V
ΔV <sub>P(low)(mute)</sub>	low supply voltage mute hysteresis		0.1	0.7	1	V
V <sub>th(ovp)</sub>	overvoltage protection threshold voltage		18	20	22	V
V <sub>hr</sub>	headroom voltage	when headroom protection is activated; see <a href="#">Figure 7</a>	1.1	1.6	2.0	V
V <sub>POR</sub>	power-on reset voltage	see <a href="#">Figure 9</a>	4.1	5.0	5.8	V
V <sub>O(offset)</sub>	output offset voltage	amplifier on	-95	0	+95	mV
		amplifier mute	-25	0	+25	mV
		line driver mode	-40	0	+40	mV
R <sub>L(tol)</sub>	load resistance tolerance	V <sub>P</sub> ≤ 18 V	3.2	4	-	Ω
		V <sub>P</sub> ≤ 16 V	1.6	2	-	Ω

**Table 17. Characteristics ...continued**

Refer to [Figure 29](#) at  $V_P = V_{P1} = V_{P2} = 14.4$  V;  $R_L = 4$   $\Omega$ ;  $f = 1$  kHz;  $R_S = 0$   $\Omega$ ; normal mode; unless otherwise specified. Tested at  $T_{amb} = 25$  °C; guaranteed for  $T_{amb} = -40$  °C to  $+105$  °C.

Symbol	Parameter	Conditions	Min	Typ	Max	Unit
<b>Mode select and second clip detection: pin STB</b>						
$V_{STB}$	voltage on pin STB	Standby mode selected				
		I <sup>2</sup> C-bus mode	-	-	1	V
		legacy mode (I <sup>2</sup> C-bus off)	-	-	1	V
		Mute selected				
		legacy mode (I <sup>2</sup> C-bus off)	2.5	-	4.5	V
		Operating mode selected				
		I <sup>2</sup> C-bus mode	2.5	-	$V_P$	V
		legacy mode (I <sup>2</sup> C-bus off)	6.5	-	$V_P$	V
		low voltage on pin STB when pulled down during clipping	<a href="#">[2]</a>			
$I_{STB}$	current on pin STB	$I_{STB} = 150$ $\mu$ A	5.6	-	6.1	V
		$I_{STB} = 500$ $\mu$ A	6.1	-	7.2	V
		$V_{STB} = 0$ V to 8.5 V				
$I_{STB}$	current on pin STB	clip detection not active; I <sup>2</sup> C-bus mode	-	4	30	$\mu$ A
		legacy mode	-	10	70	$\mu$ A
<b>Start-up, shut-down and mute timing</b>						
$t_{wake}$	wake-up time	time after wake-up via STB pin before first I <sup>2</sup> C-bus transmission is recognized; see <a href="#">Figure 3</a>	-	300	500	$\mu$ s
$I_{LO(SVR)}$	output leakage current on pin SVR		-	-	10	$\mu$ A
$t_{d(mute\_off)}$	mute off delay time	10 % of output signal; $I_{LO} = 0$ $\mu$ A <a href="#">[3]</a>				
		I <sup>2</sup> C-bus mode; with $I_{LO} = 10$ $\mu$ A $\rightarrow$ +15 ms; no DC load ( $IB1[D1] = 0$ ); low pop disabled ( $IB2[D3] = 1$ ); see <a href="#">Figure 3</a>	295	465	795	ms
		I <sup>2</sup> C-bus mode; with $I_{LO} = 10$ $\mu$ A $\rightarrow$ +20 ms; DC load active ( $IB1[D1] = 1$ ); low pop disabled ( $IB2[D3] = 1$ ); see <a href="#">Figure 4</a>	500	640	940	ms
		I <sup>2</sup> C-bus mode; with $I_{LO} = 10$ $\mu$ A $\rightarrow$ +20 ms; DC load active ( $IB1[D1] = 1$ ); low pop enabled ( $IB2[D3] = 0$ ); see <a href="#">Figure 5</a>	640	830	1190	ms
		legacy mode; with $I_{LO} = 10$ $\mu$ A $\rightarrow$ +20 ms; $V_{STB} = 7$ V; $R_{ADSEL} = 0$ $\Omega$ ; see <a href="#">Figure 6</a>	430	650	1030	ms

**Table 17. Characteristics ...continued**

Refer to [Figure 29](#) at  $V_P = V_{P1} = V_{P2} = 14.4\text{ V}$ ;  $R_L = 4\ \Omega$ ;  $f = 1\text{ kHz}$ ;  $R_S = 0\ \Omega$ ; normal mode; unless otherwise specified. Tested at  $T_{amb} = 25\text{ °C}$ ; guaranteed for  $T_{amb} = -40\text{ °C}$  to  $+105\text{ °C}$ .

Symbol	Parameter	Conditions	Min	Typ	Max	Unit	
$t_{amp\_on}$	amplifier on time	time from amplifier mute to amplifier on; 90 % of output signal; $I_{LO} = 0\ \mu\text{A}$	[3]				
		I <sup>2</sup> C-bus mode; with $I_{LO} = 10\ \mu\text{A} \rightarrow +30\text{ ms}$ ; no DC load ( $IB1[D1] = 0$ ); low pop disabled ( $IB2[D3] = 1$ ); see <a href="#">Figure 3</a>		360	520	870	ms
		I <sup>2</sup> C-bus mode; with $I_{LO} = 10\ \mu\text{A} \rightarrow +35\text{ ms}$ ; DC load active ( $IB1[D1] = 1$ ); low pop disabled ( $IB2[D3] = 1$ ); see <a href="#">Figure 4</a>		565	695	1015	ms
		I <sup>2</sup> C-bus mode; with $I_{LO} = 10\ \mu\text{A} \rightarrow +30\text{ ms}$ ; DC load active ( $IB1[D1] = 1$ ); low pop enabled ( $IB2[D3] = 0$ ); see <a href="#">Figure 5</a>		710	890	1270	ms
		legacy mode; with $I_{LO} = 10\ \mu\text{A} \rightarrow +20\text{ ms}$ ; $V_{STB} = 7\text{ V}$ ; $R_{ADSEL} = 0\ \Omega$ ; see <a href="#">Figure 6</a>		510	720	1120	ms
$t_{off}$	amplifier switch-off time	time to DC output voltage $< 0.1\text{ V}$ ; I <sup>2</sup> C-bus mode; $I_{LO} = 0\ \mu\text{A}$	[3]				
		with $I_{LO} = 10\ \mu\text{A} \rightarrow +0\text{ ms}$ ; low pop enabled ( $IB2[D3] = 0$ ); see <a href="#">Figure 4</a>		120	245	530	ms
		with $I_{LO} = 10\ \mu\text{A} \rightarrow +0\text{ ms}$ ; low pop disabled ( $IB2[D3] = 1$ ); see <a href="#">Figure 5</a>		140	280	620	ms
$t_{d(mute-on)}$	mute to on delay time	from 10 % to 90 % of output signal; $IB2[D1]$ and $IB2[D2] = 1$ to 0; $V_i = 50\text{ mV}$ ; see <a href="#">Figure 6</a>	-	20	40	ms	
$t_{d(soft\_mute)}$	soft mute delay time	from 90 % to 10 % of output signal; $V_i = 50\text{ mV}$ ; $IB2[D1]$ and $IB2[D2] = 0$ to 1 (soft mute); see <a href="#">Figure 6</a>	-	20	40	ms	
$t_{d(fast\_mute)}$	fast mute delay time	from 90 % to 10 % of output signal; $V_{STB}$ from 8 V to 1.3 V (fast mute); see <a href="#">Figure 6</a>	-	0.1	1	ms	
$t_{(start-Vo(off))}$	engine start to output off time	$V_P$ from 14.4 V to 7 V; $V_o < 0.5\text{ V}$ ; see <a href="#">Figure 8</a>	-	0.1	1	ms	
$t_{(start-SVR(off))}$	engine start to SVR off time	$V_P$ from 14.4 V to 7 V; $V_{SVR} < 2\text{ V}$ ; see <a href="#">Figure 8</a>	-	40	75	ms	
<b>I<sup>2</sup>C-bus interface<sup>[4]</sup></b>							
$V_{IL}$	LOW-level input voltage	pins SCL and SDA	-	-	1.5	V	
$V_{IH}$	HIGH-level input voltage	pins SCL and SDA	2.3	-	5.5	V	
$V_{OL}$	LOW-level output voltage	pin SDA; $I_L = 5\text{ mA}$	-	-	0.4	V	

**Table 17. Characteristics ...continued**

Refer to [Figure 29](#) at  $V_P = V_{P1} = V_{P2} = 14.4\text{ V}$ ;  $R_L = 4\ \Omega$ ;  $f = 1\text{ kHz}$ ;  $R_S = 0\ \Omega$ ; normal mode; unless otherwise specified. Tested at  $T_{amb} = 25\text{ °C}$ ; guaranteed for  $T_{amb} = -40\text{ °C}$  to  $+105\text{ °C}$ .

Symbol	Parameter	Conditions	Min	Typ	Max	Unit
$f_{SCL}$	SCL clock frequency		-	400	-	kHz
$R_{ADSEL}$	resistance on pin ADSEL	I <sup>2</sup> C-bus address A[6:0] = 110 1100	155	-	-	k $\Omega$
		I <sup>2</sup> C-bus address A[6:0] = 110 1101	42	51	57	k $\Omega$
		I <sup>2</sup> C-bus address A[6:0] = 110 1111	7	10	15	k $\Omega$
		legacy mode	-	-	0.5	k $\Omega$
<b>Diagnostic</b>						
$V_{OL(DIAG)}$	LOW-level output voltage on pin DIAG	fault condition; $I_{DIAG} = 1\text{ mA}$	-	-	0.3	V
$V_{O(offset\_det)}$	output voltage at offset detection		$\pm 1.5$	$\pm 1.75$	$\pm 2.2$	V
$THD_{clip}$	total harmonic distortion clip detection level	IB2[D7:D6] = 10	5	10	18	%
		IB2[D7:D6] = 01	3	5	9	%
		IB2[D7:D6] = 00	1	2	3	%
$\Delta THD_{clip}$	total harmonic distortion clip detection level variation	no overlap between IB2[D7:D6] = 10 and IB2[D7:D6] = 01	1	4	9	%
		no overlap between IB2[D7:D6] = 01 and IB2[D7:D6] = 00	1	3.5	6	%
$T_{j(AV)(pwarn)}$	pre-warning average junction temperature	IB3[D4] = 0	135	145	155	°C
		IB3[D4] = 1	112	122	132	°C
$T_{j(AV)(G(-0.5dB))}$	average junction temperature for 0.5 dB gain reduction	$V_i = 0.05\text{ V}$	150	155	160	°C
$\Delta T_{j(pw-G(-0.5dB))}$	prewarning to 0.5 dB gain reduction junction temperature difference		7	10	13	°C
$\Delta T_{j(G(-0.5dB)-of)}$	junction temperature difference between 0.5 dB gain reduction and off	from thermal foldback to when all outputs are switched off	10	15	20	°C
$\Delta G_{(th\_fold)}$	gain reduction of thermal foldback	all channels switched off	-	20	-	dB
$Z_{th(load)}$	load detection threshold impedance	I <sup>2</sup> C-bus mode				
		normal load detection	-	-	20	$\Omega$
		line driver load detection	100	-	800	$\Omega$
$Z_{th(open)}$	open load detection threshold impedance	I <sup>2</sup> C-bus mode	5000	-	-	$\Omega$
$I_{th(o)det(load)AC}$	AC load detection output threshold current	I <sup>2</sup> C-bus mode				
		AC load bit is set	460	-	-	mA
		AC load bit is not set	-	-	230	mA

**Table 17. Characteristics ...continued**

Refer to [Figure 29](#) at  $V_P = V_{P1} = V_{P2} = 14.4$  V;  $R_L = 4$   $\Omega$ ;  $f = 1$  kHz;  $R_S = 0$   $\Omega$ ; normal mode; unless otherwise specified. Tested at  $T_{amb} = 25$  °C; guaranteed for  $T_{amb} = -40$  °C to  $+105$  °C.

Symbol	Parameter	Conditions	Min	Typ	Max	Unit
<b>Amplifier</b>						
$P_o$	output power	$R_L = 4$ $\Omega$ ; $V_P = 14.4$ V; THD = 0.5 %	19	22	-	W
		$R_L = 4$ $\Omega$ ; $V_P = 14.4$ V; THD = 10 %	26	28	-	W
		$R_L = 4$ $\Omega$ ; $V_P = 14.4$ V; maximum power; $V_i = 2$ V (RMS) square wave	42	44	-	W
		$R_L = 4$ $\Omega$ ; $V_P = 15.2$ V; maximum power; $V_i = 2$ V (RMS) square wave	47	50	-	W
		$R_L = 2$ $\Omega$ ; $V_P = 14.4$ V; THD = 0.5 %	34	37	-	W
		$R_L = 2$ $\Omega$ ; $V_P = 14.4$ V; THD = 10 %	45	48	-	W
		$R_L = 2$ $\Omega$ ; $V_P = 14.4$ V; maximum power; $V_i = 2$ V (RMS) square wave	70	75	-	W
THD	total harmonic distortion	$P_o = 1$ W to 12 W; $f = 1$ kHz; $R_L = 4$ $\Omega$	-	0.01	0.1	%
		$P_o = 1$ W to 12 W; $f = 10$ kHz	-	0.09	0.3	%
		$P_o = 1$ W to 12 W; $f = 20$ kHz	-	0.14	0.4	%
		line driver mode; $V_o = 1$ V (RMS) and 5 V (RMS), $f = 20$ Hz to 20 kHz; complex load; see <a href="#">Figure 31</a>	-	0.02	0.05	%
$\alpha_{cs}$	channel separation	$f = 1$ kHz; $R_S = 1$ k $\Omega$ ; $R_{ACGND} = 250$ $\Omega$	<a href="#">5</a> 65	80	-	dB
		$f = 10$ kHz; $R_S = 1$ k $\Omega$ ; $R_{ACGND} = 250$ $\Omega$	<a href="#">5</a> 60	65	-	dB
SVRR	supply voltage ripple rejection	100 Hz to 10 kHz; $R_S = 1$ k $\Omega$ ; $R_{ACGND} = 250$ $\Omega$	<a href="#">5</a> 55	70	-	dB
CMRR	common mode rejection ratio	normal mode; $V_{cm} = 0.3$ V (p-p); $f = 1$ kHz to 3 kHz; $R_S = 1$ k $\Omega$ ; $R_{ACGND} = 250$ $\Omega$	<a href="#">5</a> 45	65	-	dB
$V_{cm(max)(rms)}$	maximum common mode voltage (RMS value)	$f = 1$ kHz	-	-	0.6	V
$V_{n(o)}$	output noise voltage	filter 20 Hz to 22 kHz; $R_S = 1$ k $\Omega$				
		mute mode	-	19	26	$\mu$ V
		line driver mode	-	22	29	$\mu$ V
$G_v$	voltage gain	single-ended in; differential out				
		normal mode	25.5	26	26.5	dB
		line driver mode	15.5	16	16.5	dB

**Table 17. Characteristics ...continued**

Refer to [Figure 29](#) at  $V_P = V_{P1} = V_{P2} = 14.4\text{ V}$ ;  $R_L = 4\ \Omega$ ;  $f = 1\text{ kHz}$ ;  $R_S = 0\ \Omega$ ; normal mode; unless otherwise specified. Tested at  $T_{amb} = 25\text{ °C}$ ; guaranteed for  $T_{amb} = -40\text{ °C}$  to  $+105\text{ °C}$ .

Symbol	Parameter	Conditions	Min	Typ	Max	Unit
$Z_i$	input impedance	$T_{amb} = -40\text{ °C}$ to $+105\text{ °C}$	50	70	95	k $\Omega$
		$T_{amb} = 0\text{ °C}$ to $105\text{ °C}$	60	70	95	k $\Omega$
$\alpha_{mute}$	mute attenuation	$V_o / V_{o(mute)}$ ; $V_i = 50\text{ mV}$	80	92	-	dB
$V_{o(mute)(RMS)}$	RMS mute output voltage	$V_i = 1\text{ V (RMS)}$ ; filter 20 Hz to 22 kHz	-	25	-	$\mu\text{V}$
$B_p$	power bandwidth	-1 dB	-	20 to 20000	-	Hz

- [1] Operation above 16 V in a 2  $\Omega$  mode with reactive load can trigger the amplifier protection. The amplifier switches off and will restart after 16 ms resulting in an 'audio hole'.
- [2]  $V_{STB}$  depends on the current into the STB pin: minimum =  $(1429 \times I_{STB}) + 5.4\text{ V}$ , maximum =  $(3143 \times I_{STB}) + 5.6\text{ V}$ .
- [3] The times are specified without leakage current. For a leakage current of 10  $\mu\text{A}$  on the SVR pin, the delta time is specified. If the capacitor value on the SVR pin changes with  $\pm 30\%$ , the specified time will also change with  $\pm 30\%$ . The specified times include an Equivalent Series Resistance (ESR) of 15  $\Omega$  for the capacitor on the SVR pin.
- [4] Standard I<sup>2</sup>C-bus specification: maximum LOW level =  $0.3 \times V_{DD}$ , minimum HIGH level =  $0.7 \times V_{DD}$ . To comply with 5 V and 3.3 V logic, the maximal LOW level is defined by  $V_{DD} = 5\text{ V}$  and the minimum HIGH level by  $V_{DD} = 3.3\text{ V}$ .
- [5] For optimum channel separation, supply voltage ripple rejection and common mode rejection ratio, a resistor  $R_{ACGND} = \frac{R_S}{4}\ \Omega$  should be in series with the ACGND capacitor.

## 12. Performance diagrams

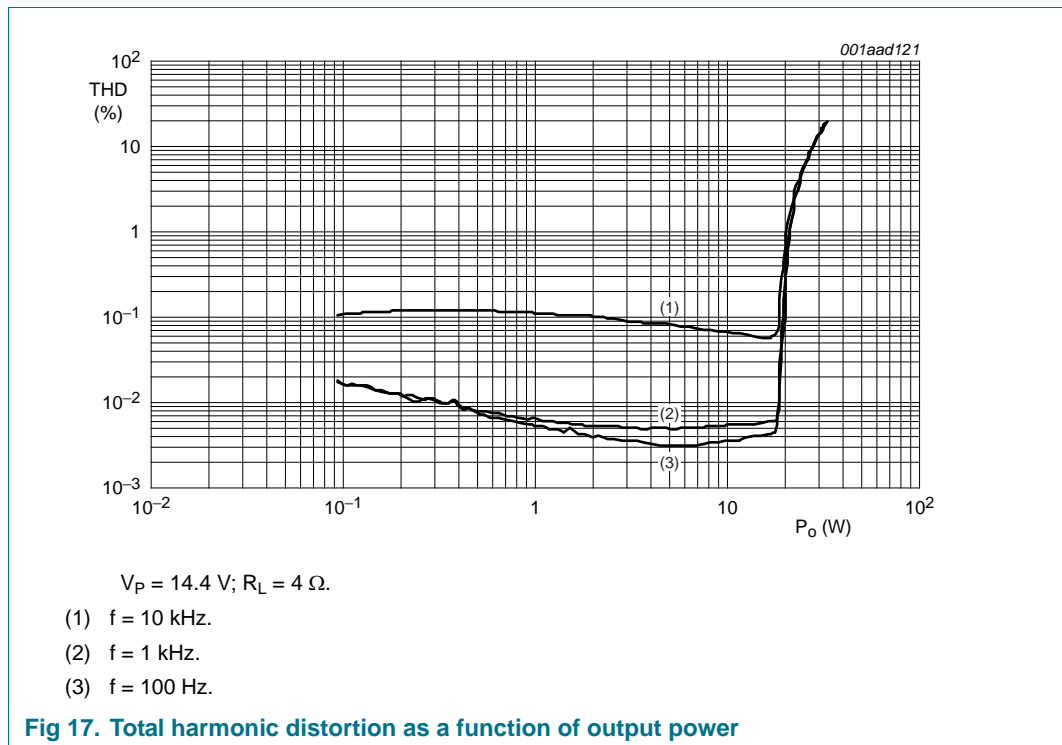



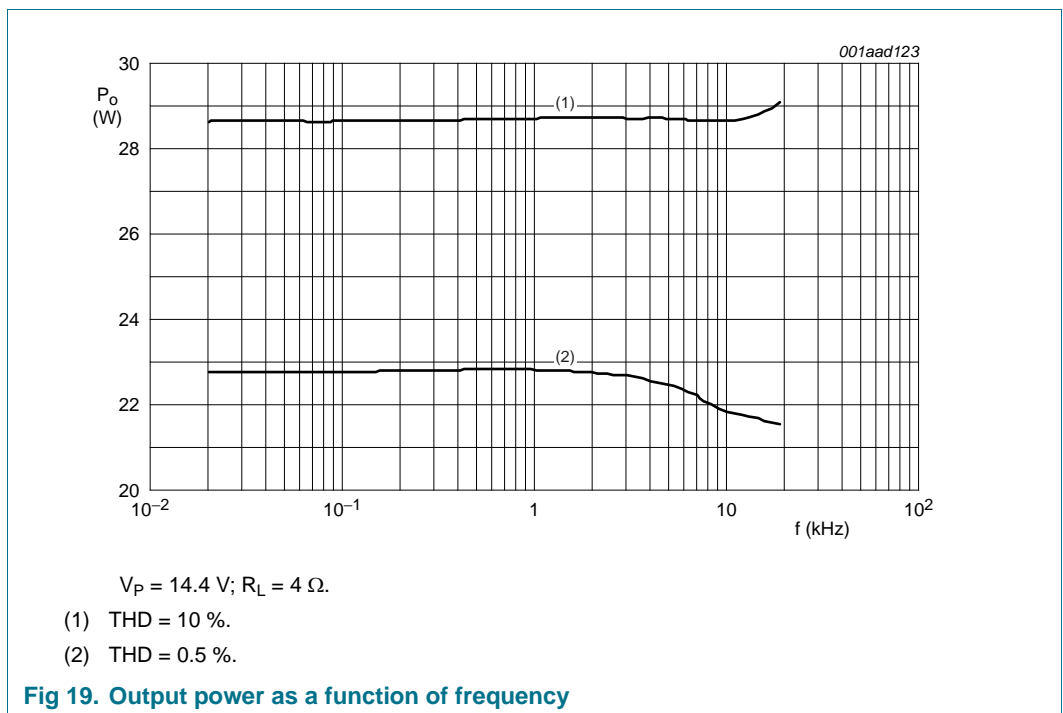
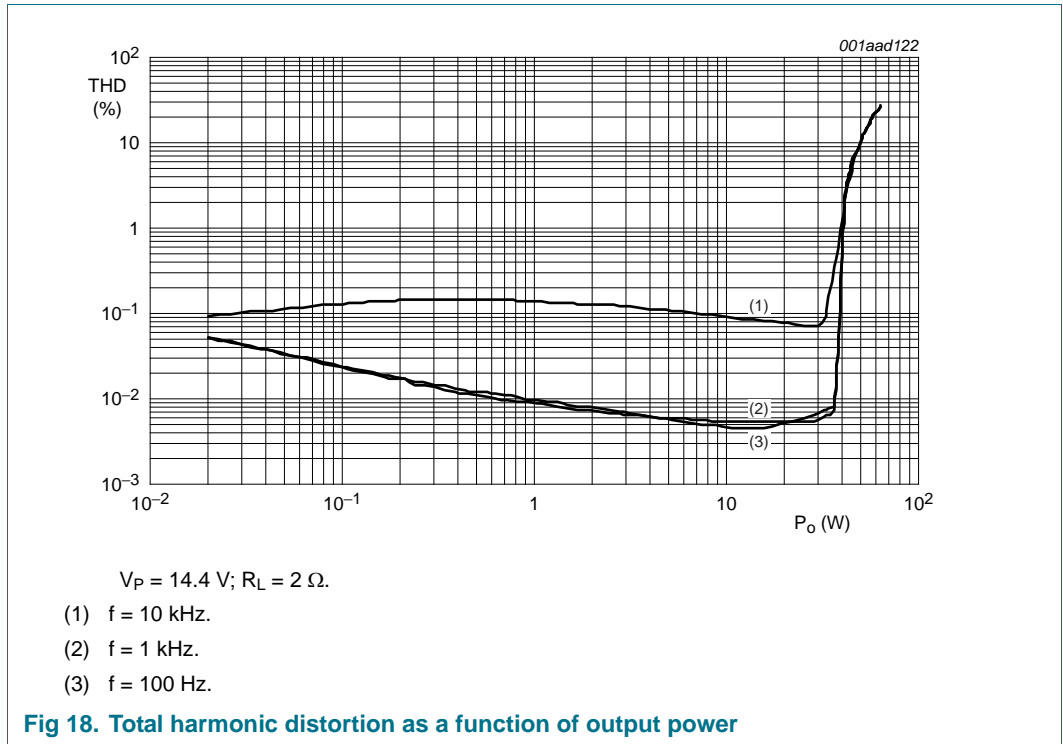

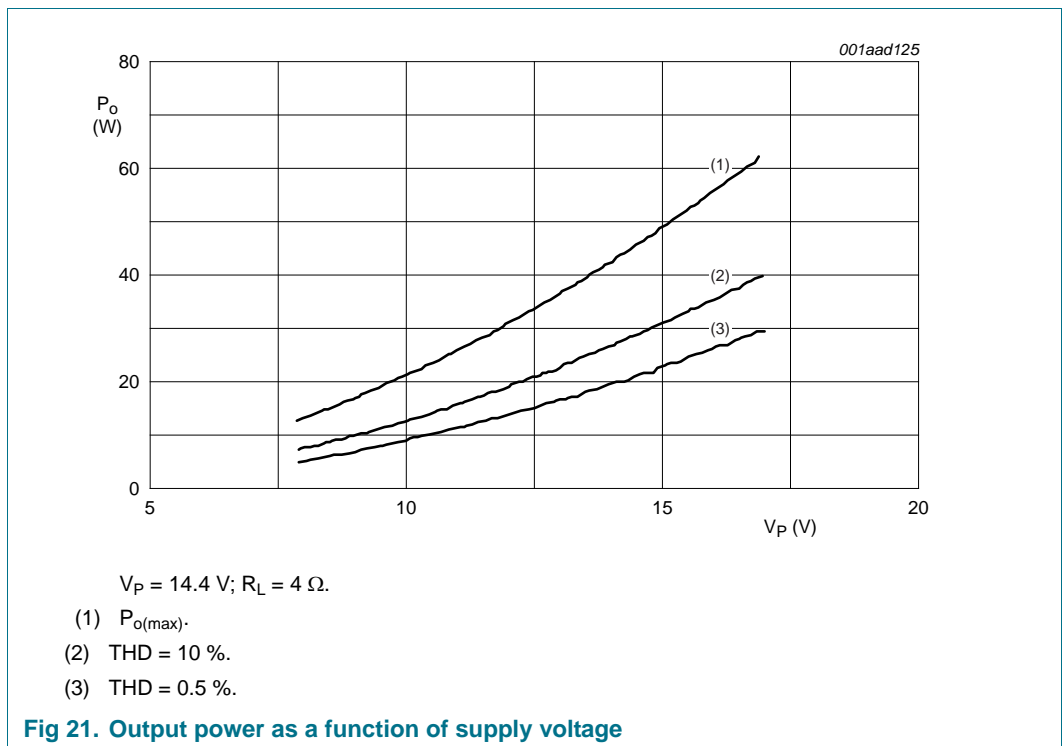
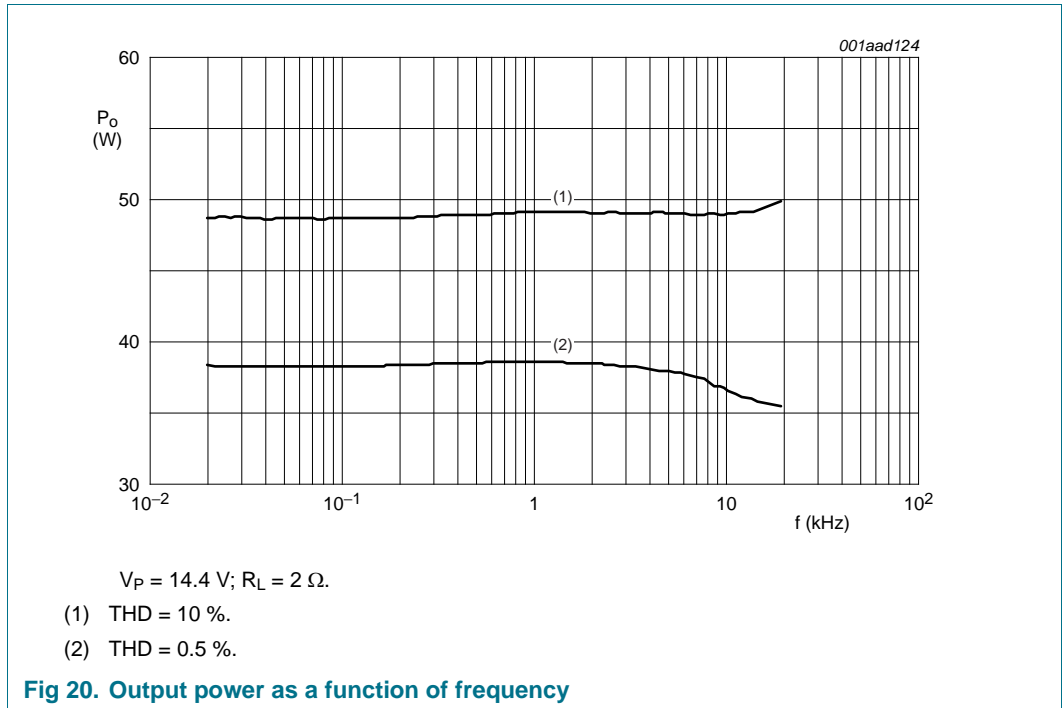

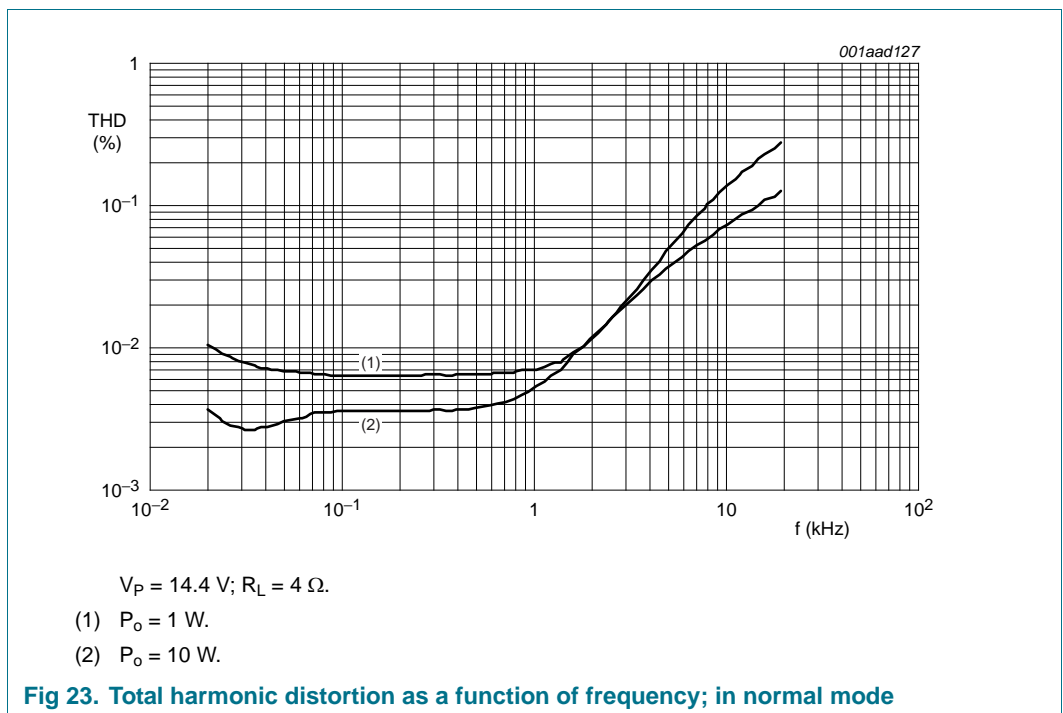
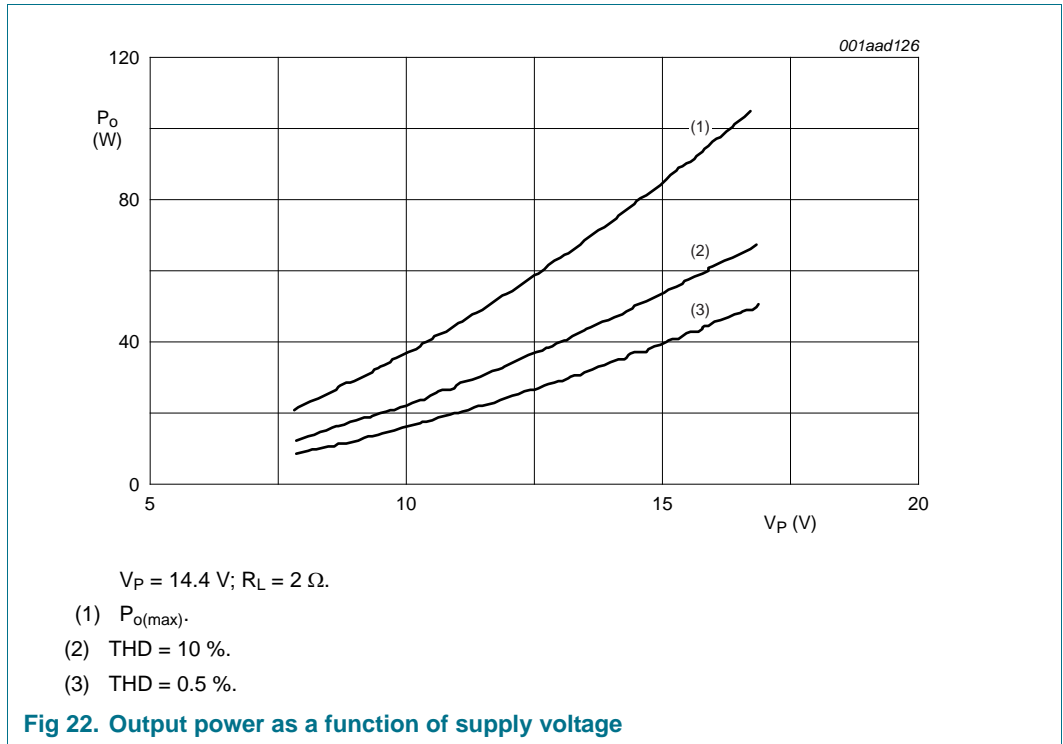

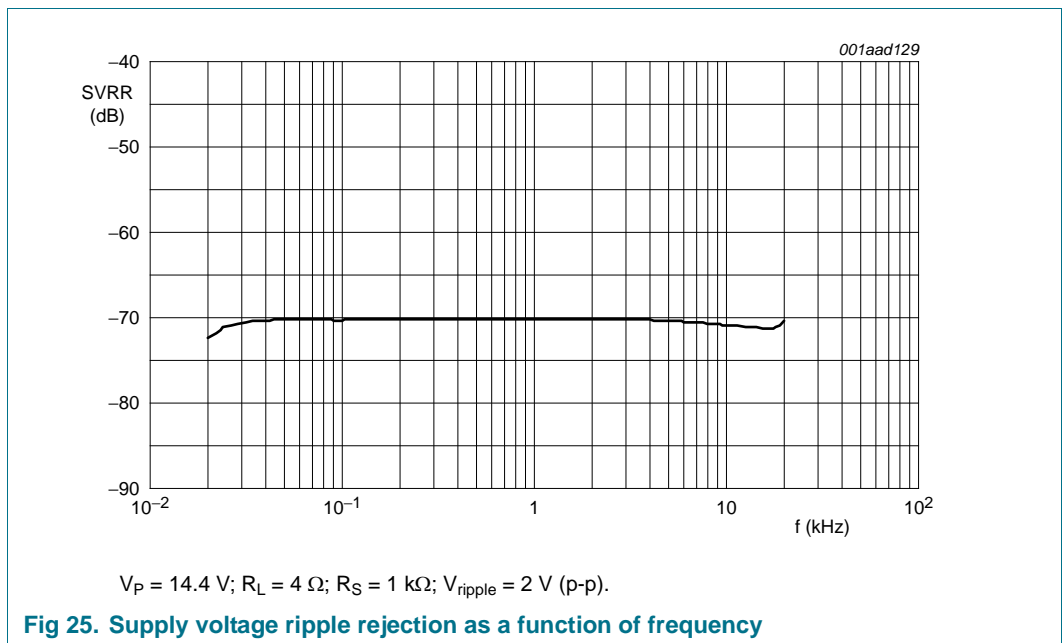
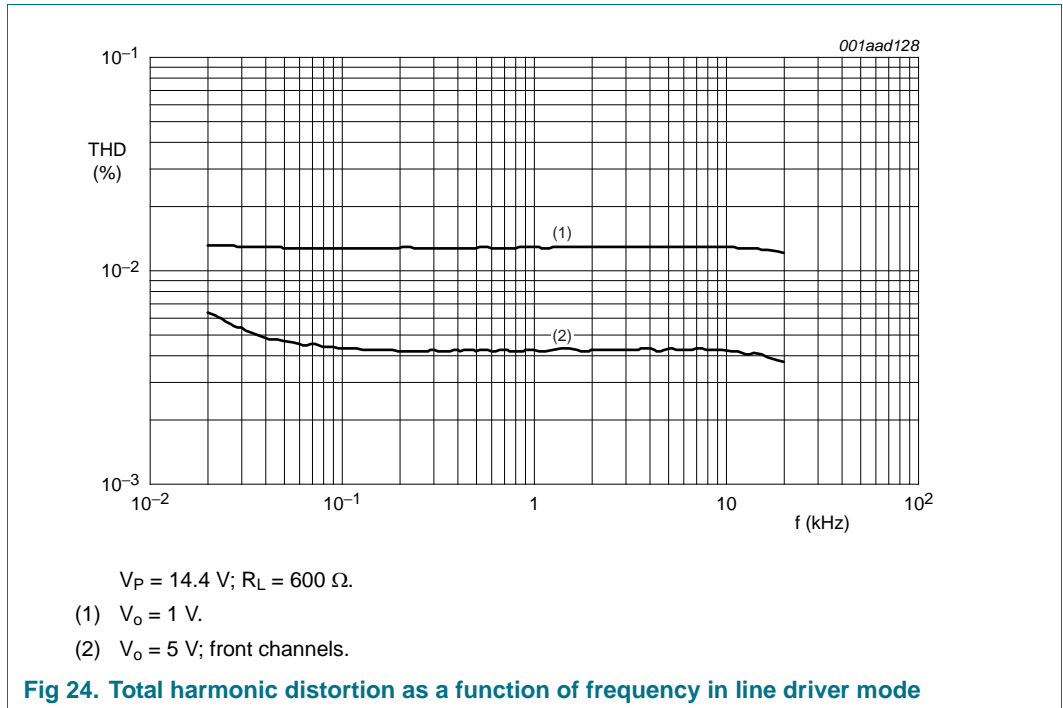

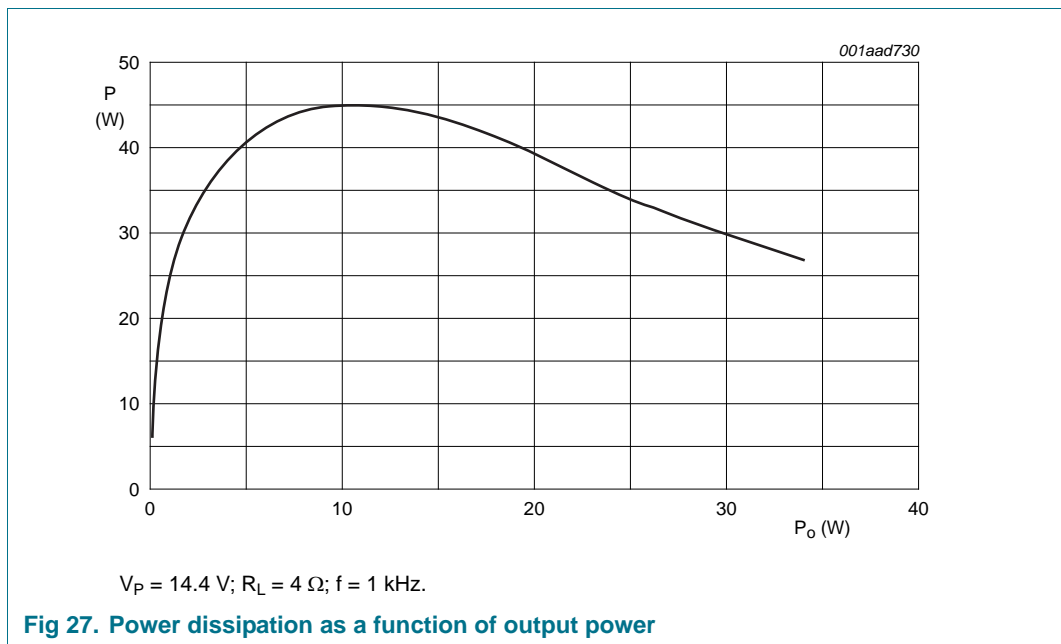
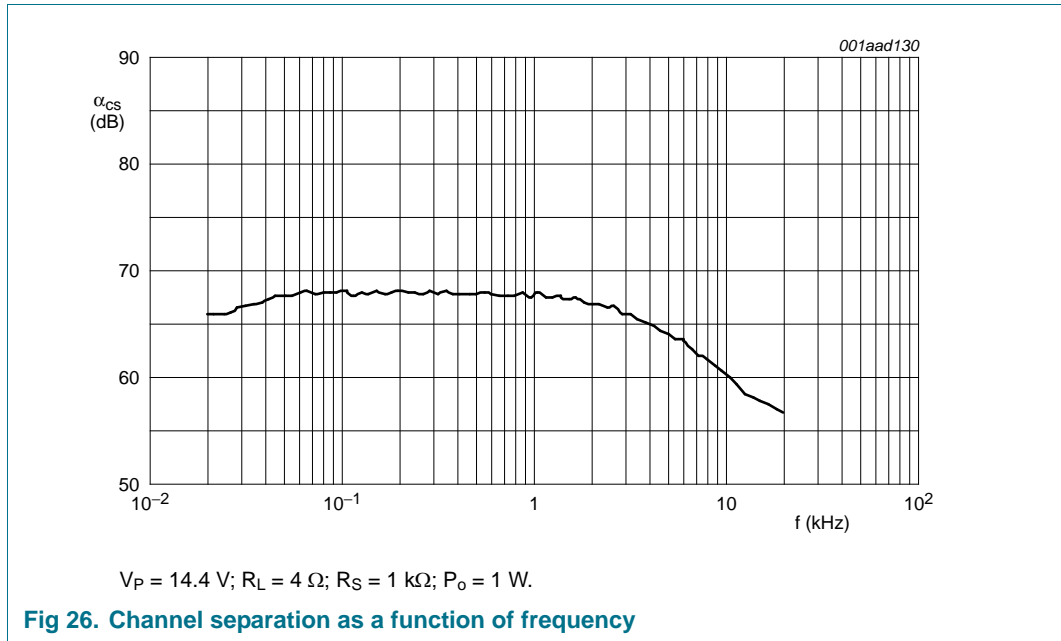

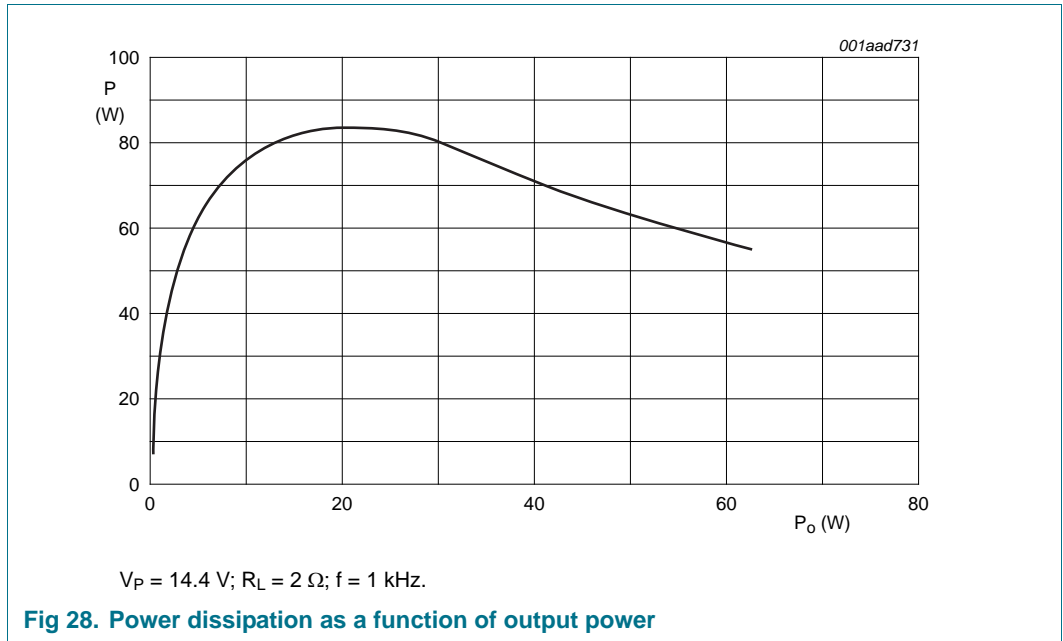

13. Application information

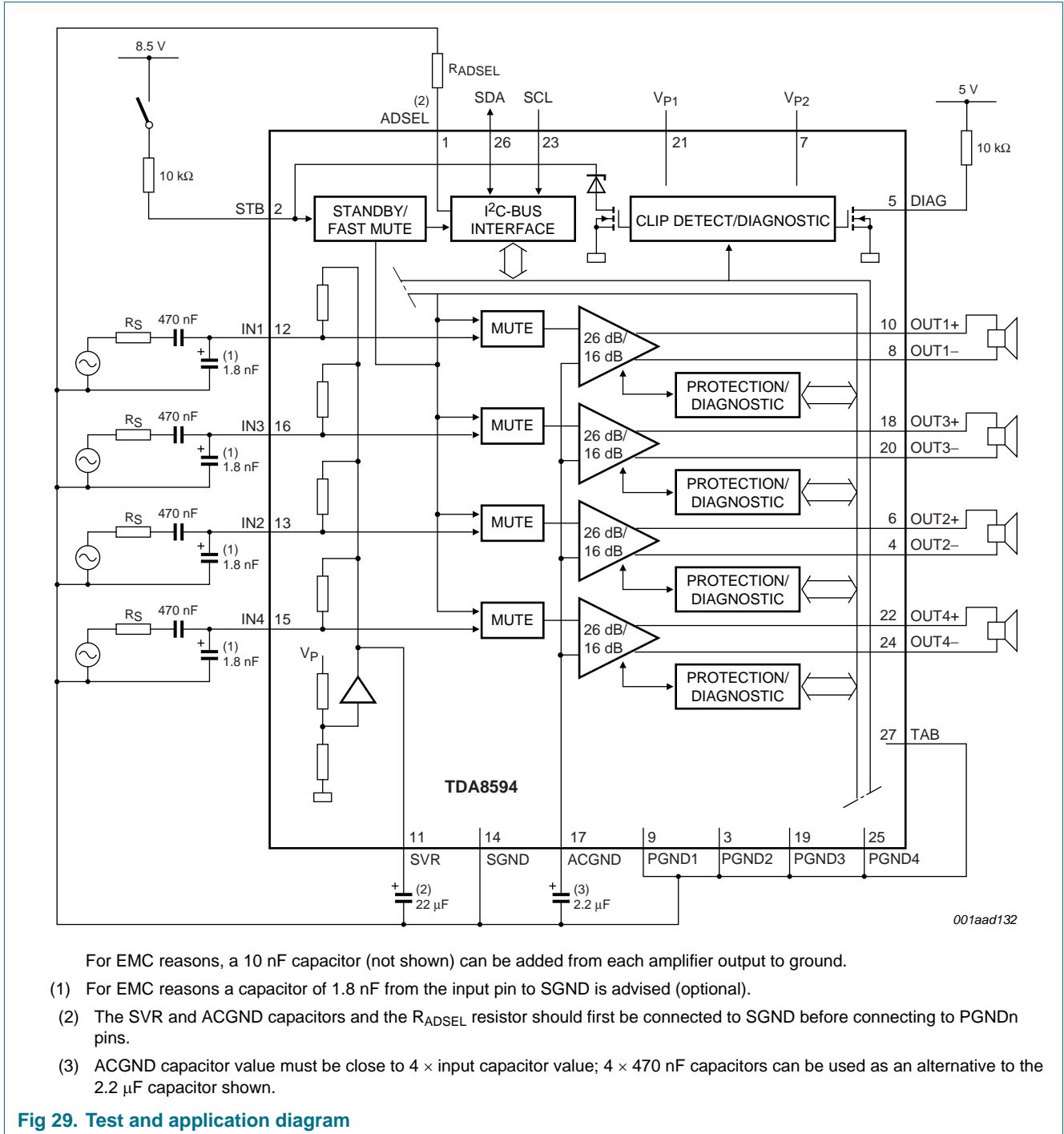

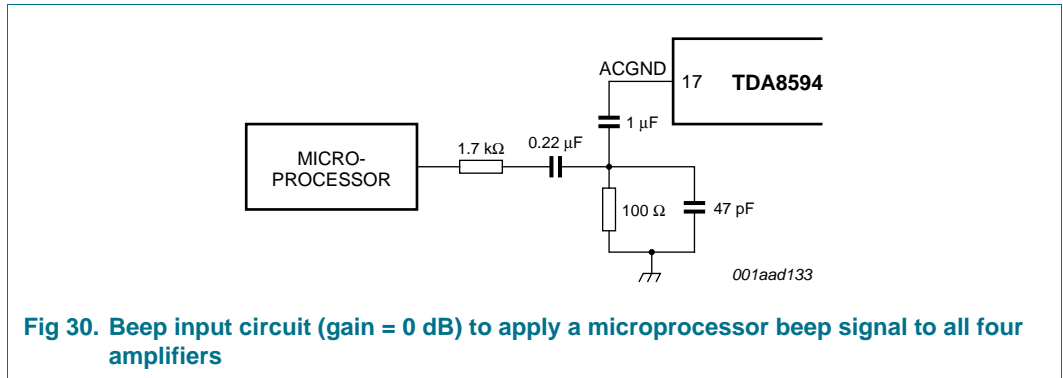

Fig 30. Beep input circuit (gain = 0 dB) to apply a microprocessor beep signal to all four amplifiers

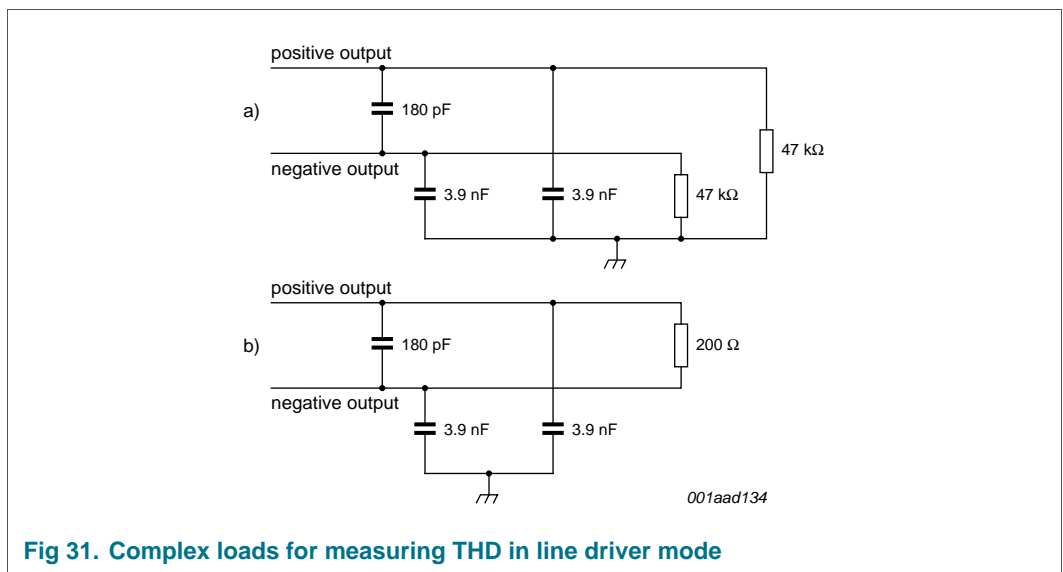

Fig 31. Complex loads for measuring THD in line driver mode

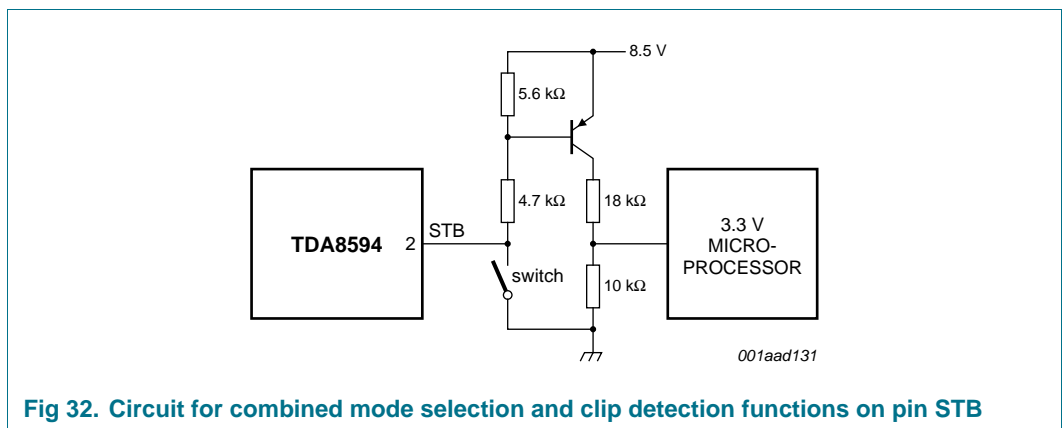
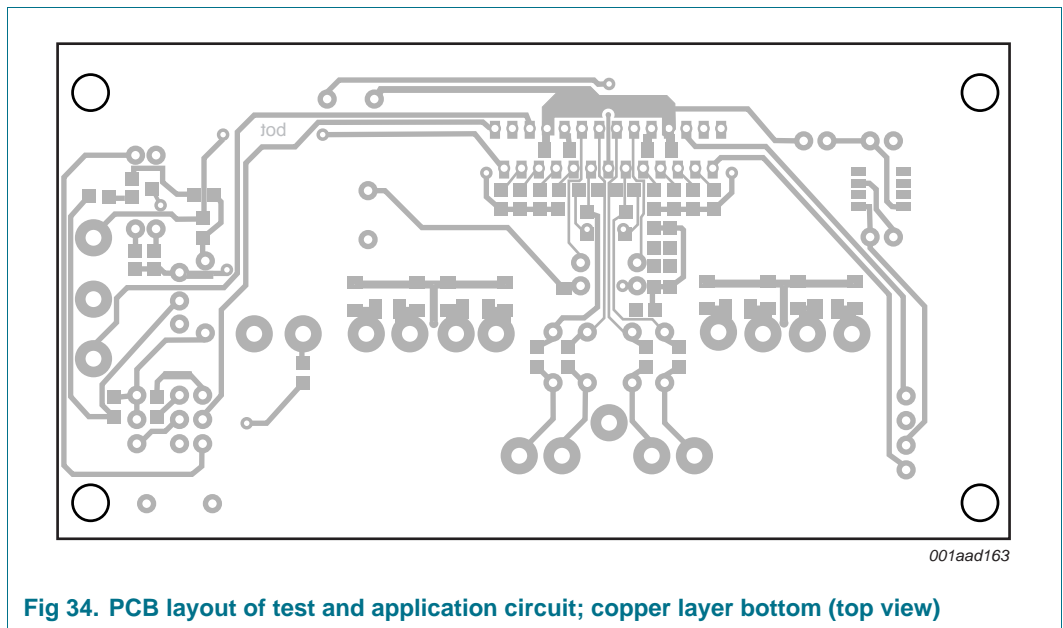
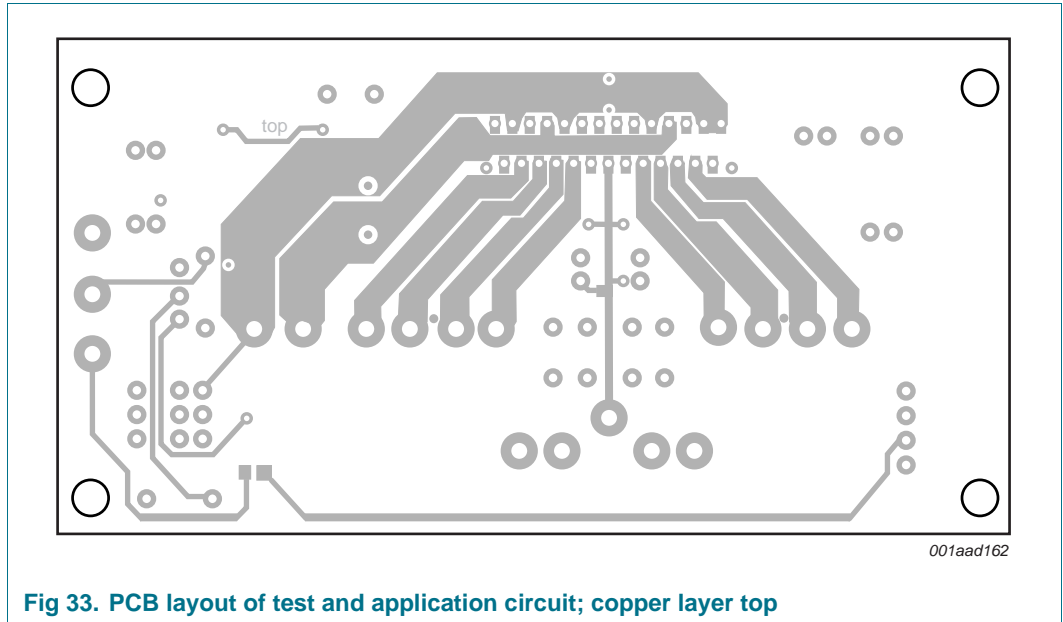

Fig 32. Circuit for combined mode selection and clip detection functions on pin STB



### 13.1 PCB layout



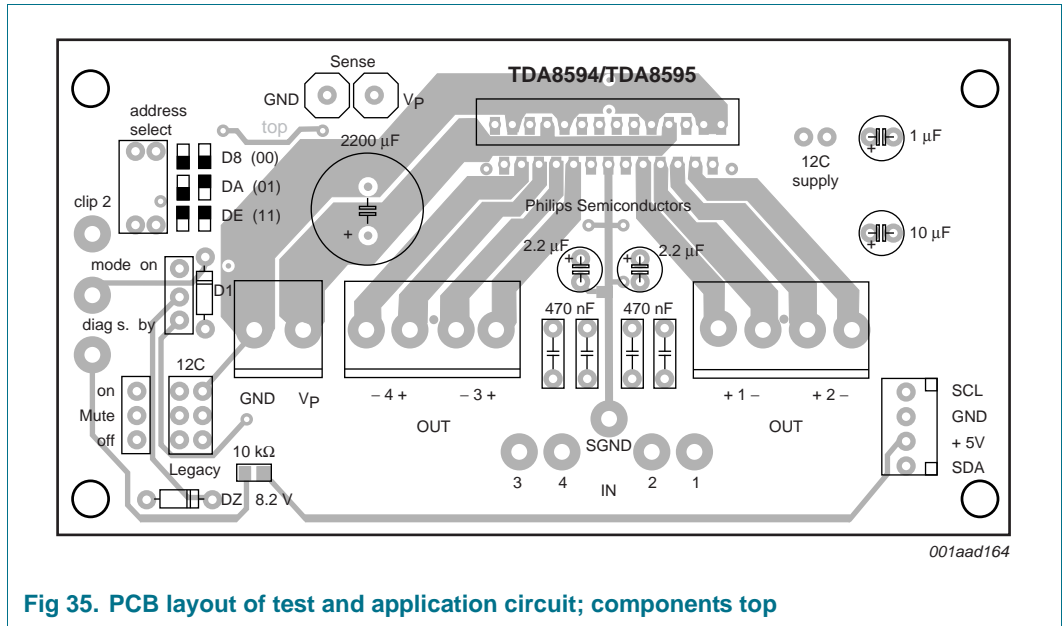

Fig 35. PCB layout of test and application circuit; components top

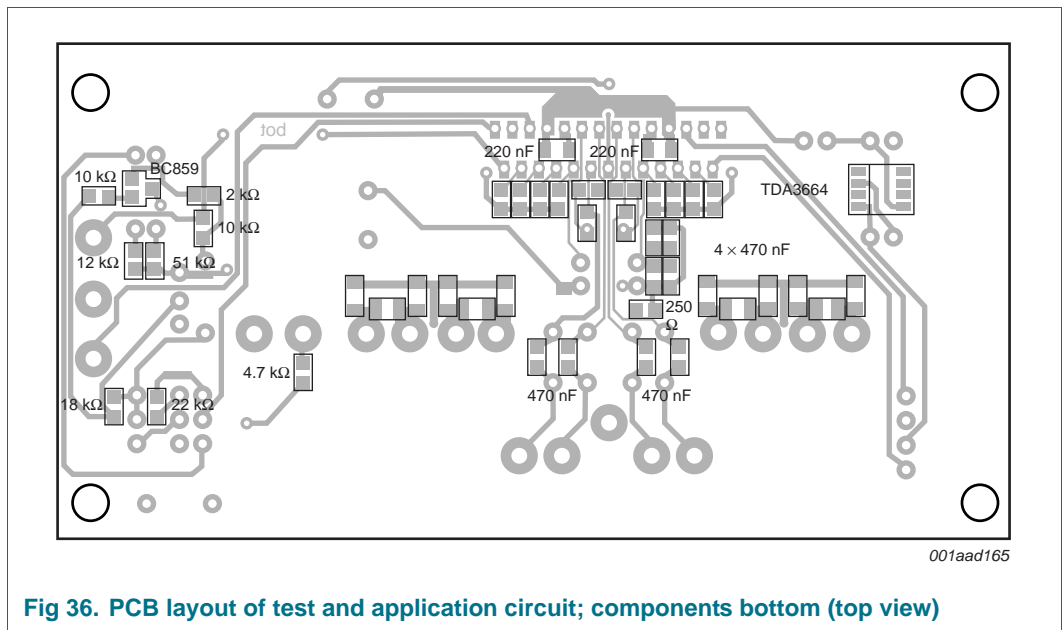

Fig 36. PCB layout of test and application circuit; components bottom (top view)

## 14. Test information

### 14.1 Quality information

This product has been qualified in accordance with the Automotive Electronics Council (AEC) standard Q100 - *Failure mechanism based stress test qualification for integrated circuits*, and is suitable for use in automotive applications.

15. Package outline

DBS27P: plastic DIL-bent-SIL (special bent) power package; 27 leads (lead length 6.8 mm)

SOT827-1

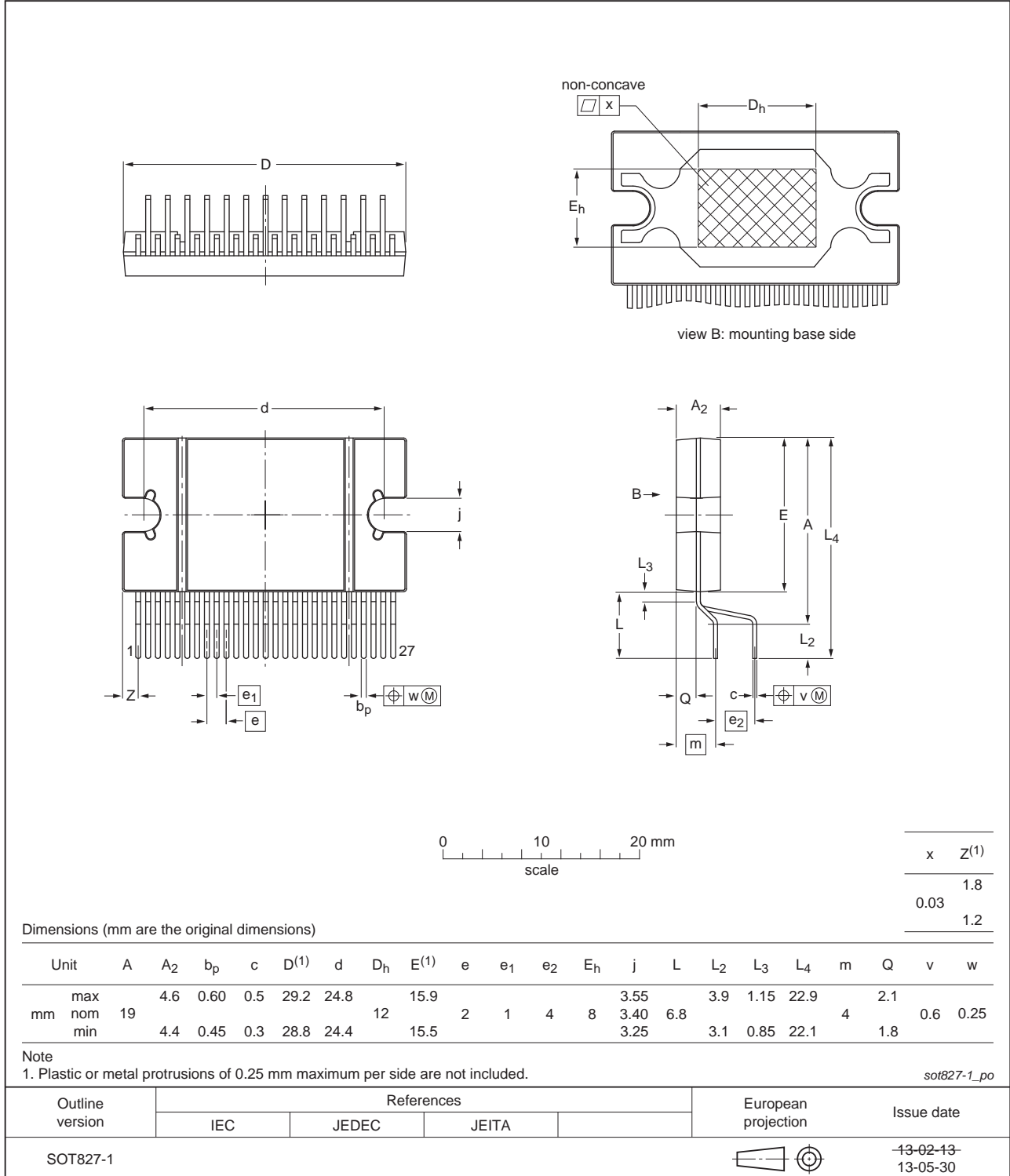

Fig 37. Package outline SOT827-1 (DBS27P)

RDBS27P: plastic rectangular-DIL-bent-SIL (reverse bent) power package; 27 leads (row spacing 2.54 mm)

SOT878-1

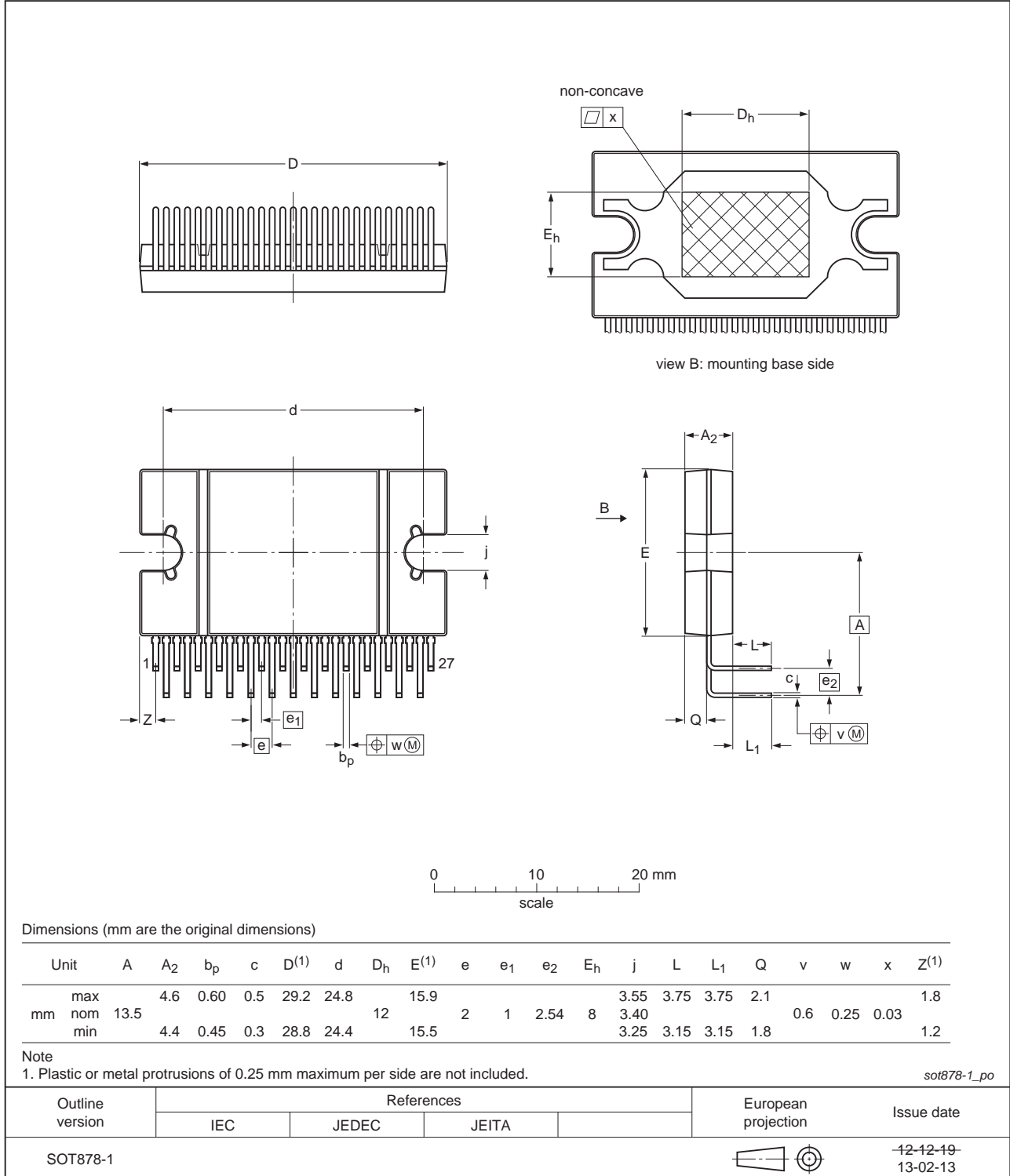
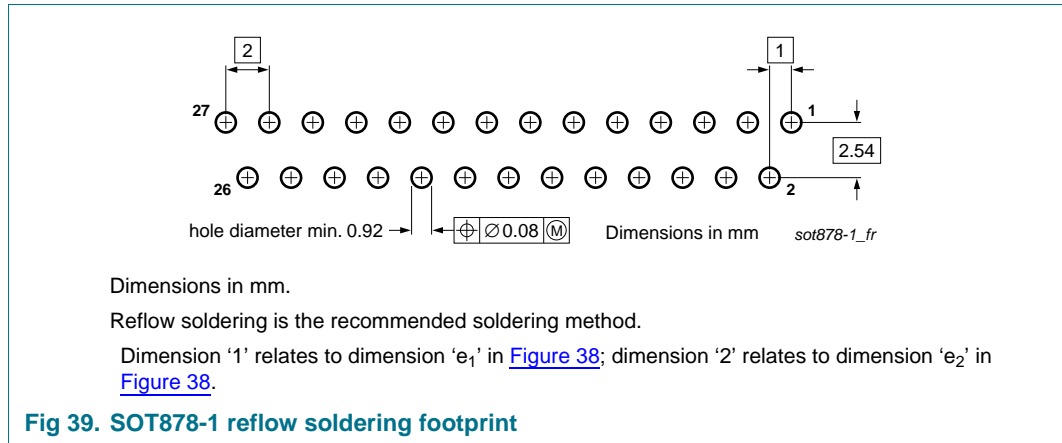

Fig 38. Package outline SOT878-1 (RDBS27P)

## 16. Mounting



## 17. Abbreviations

**Table 18. Abbreviations**

Acronym	Description
ACK	ACKnowledge not
BCDMOS	Bipolar CMOS/DMOS
BTL	Bridge Tied Load
CMOS	Complementary Metal-Oxide Semiconductor
DMOS	Double-diffused Metal-Oxide Semiconductor
DSP	Digital Signal Processor
EMC	ElectroMagnetic Compatibility
ESR	Equivalent Series Resistance
LSB	Least Significant Bit
MSB	Most Significant Bit
NMOS	Negative-channel Metal-Oxide Semiconductor
PMOS	Positive-channel Metal-Oxide Semiconductor
PCB	Printed-Circuit Board
POR	Power-On Reset
SOAR	Safe Operating ARea
SOI	Silicon On Insulator

## 18. Revision history

Table 19. Revision history

Document ID	Release date	Data sheet status	Change notice	Supersedes
TDA8594 v.5	20130611	Product data sheet	-	TDA8594_4
Modifications:	<ul style="list-style-type: none"> <li>The package outline <a href="#">Figure 37</a> has been updated.</li> </ul>			
TDA8594 v.4	20130226	Product data sheet	-	TDA8594_3
Modifications:	<ul style="list-style-type: none"> <li>The data sheet template has been updated to the latest version.</li> </ul>			
TDA8594 v.3	20130221	Product data sheet	-	TDA8594_2
Modifications:	<ul style="list-style-type: none"> <li>The package outline figures, Figure 37 and Figure 38, have been updated.</li> </ul>			
TDA8594_2	20071211	Product data sheet	-	TDA8594_1
Modifications:	<ul style="list-style-type: none"> <li>The format of this data sheet has been redesigned to comply with the new identity guidelines of NXP Semiconductors.</li> <li>Legal texts have been adapted to the new company name where appropriate.</li> <li>Section 2.1 and Section 14: Added device qualification "AEC-Q100 qualification".</li> <li>Figure 1 and Figure 29: Changed internal circuit on pin SVR.</li> <li>Figure 32: Value of base-emitter resistor changed to 5.6 kΩ.</li> <li>Table 17, Diagnostic: <ul style="list-style-type: none"> <li>Symbols and parameters of "junction temperature" characteristics updated (4×).</li> <li>(Old) symbol and parameter "<math>I_{oM}</math> = peak current output" changed to "<math>I_{th(o)det(load)AC}</math> = AC load detection output threshold current".</li> </ul> </li> </ul>			
TDA8594_1 (9397 750 15066)	20060302	Product data sheet	-	-

## 19. Legal information

### 19.1 Data sheet status

Document status <sup>[1][2]</sup>	Product status <sup>[3]</sup>	Definition
Objective [short] data sheet	Development	This document contains data from the objective specification for product development.
Preliminary [short] data sheet	Qualification	This document contains data from the preliminary specification.
Product [short] data sheet	Production	This document contains the product specification.

[1] Please consult the most recently issued document before initiating or completing a design.

[2] The term 'short data sheet' is explained in section "Definitions".

[3] The product status of device(s) described in this document may have changed since this document was published and may differ in case of multiple devices. The latest product status information is available on the Internet at URL <http://www.nxp.com>.

### 19.2 Definitions

**Draft** — The document is a draft version only. The content is still under internal review and subject to formal approval, which may result in modifications or additions. NXP Semiconductors does not give any representations or warranties as to the accuracy or completeness of information included herein and shall have no liability for the consequences of use of such information.

**Short data sheet** — A short data sheet is an extract from a full data sheet with the same product type number(s) and title. A short data sheet is intended for quick reference only and should not be relied upon to contain detailed and full information. For detailed and full information see the relevant full data sheet, which is available on request via the local NXP Semiconductors sales office. In case of any inconsistency or conflict with the short data sheet, the full data sheet shall prevail.

**Product specification** — The information and data provided in a Product data sheet shall define the specification of the product as agreed between NXP Semiconductors and its customer, unless NXP Semiconductors and customer have explicitly agreed otherwise in writing. In no event however, shall an agreement be valid in which the NXP Semiconductors product is deemed to offer functions and qualities beyond those described in the Product data sheet.

### 19.3 Disclaimers

**Limited warranty and liability** — Information in this document is believed to be accurate and reliable. However, NXP Semiconductors does not give any representations or warranties, expressed or implied, as to the accuracy or completeness of such information and shall have no liability for the consequences of use of such information. NXP Semiconductors takes no responsibility for the content in this document if provided by an information source outside of NXP Semiconductors.

In no event shall NXP Semiconductors be liable for any indirect, incidental, punitive, special or consequential damages (including - without limitation - lost profits, lost savings, business interruption, costs related to the removal or replacement of any products or rework charges) whether or not such damages are based on tort (including negligence), warranty, breach of contract or any other legal theory.

Notwithstanding any damages that customer might incur for any reason whatsoever, NXP Semiconductors' aggregate and cumulative liability towards customer for the products described herein shall be limited in accordance with the *Terms and conditions of commercial sale* of NXP Semiconductors.

**Right to make changes** — NXP Semiconductors reserves the right to make changes to information published in this document, including without limitation specifications and product descriptions, at any time and without notice. This document supersedes and replaces all information supplied prior to the publication hereof.

**Suitability for use** — NXP Semiconductors products are not designed, authorized or warranted to be suitable for use in life support, life-critical or safety-critical systems or equipment, nor in applications where failure or malfunction of an NXP Semiconductors product can reasonably be expected to result in personal injury, death or severe property or environmental damage. NXP Semiconductors and its suppliers accept no liability for inclusion and/or use of NXP Semiconductors products in such equipment or applications and therefore such inclusion and/or use is at the customer's own risk.

**Applications** — Applications that are described herein for any of these products are for illustrative purposes only. NXP Semiconductors makes no representation or warranty that such applications will be suitable for the specified use without further testing or modification.

Customers are responsible for the design and operation of their applications and products using NXP Semiconductors products, and NXP Semiconductors accepts no liability for any assistance with applications or customer product design. It is customer's sole responsibility to determine whether the NXP Semiconductors product is suitable and fit for the customer's applications and products planned, as well as for the planned application and use of customer's third party customer(s). Customers should provide appropriate design and operating safeguards to minimize the risks associated with their applications and products.

NXP Semiconductors does not accept any liability related to any default, damage, costs or problem which is based on any weakness or default in the customer's applications or products, or the application or use by customer's third party customer(s). Customer is responsible for doing all necessary testing for the customer's applications and products using NXP Semiconductors products in order to avoid a default of the applications and the products or of the application or use by customer's third party customer(s). NXP does not accept any liability in this respect.

**Limiting values** — Stress above one or more limiting values (as defined in the Absolute Maximum Ratings System of IEC 60134) will cause permanent damage to the device. Limiting values are stress ratings only and (proper) operation of the device at these or any other conditions above those given in the Recommended operating conditions section (if present) or the Characteristics sections of this document is not warranted. Constant or repeated exposure to limiting values will permanently and irreversibly affect the quality and reliability of the device.

**Terms and conditions of commercial sale** — NXP Semiconductors products are sold subject to the general terms and conditions of commercial sale, as published at <http://www.nxp.com/profile/terms>, unless otherwise agreed in a valid written individual agreement. In case an individual agreement is concluded only the terms and conditions of the respective agreement shall apply. NXP Semiconductors hereby expressly objects to applying the customer's general terms and conditions with regard to the purchase of NXP Semiconductors products by customer.

**No offer to sell or license** — Nothing in this document may be interpreted or construed as an offer to sell products that is open for acceptance or the grant, conveyance or implication of any license under any copyrights, patents or other industrial or intellectual property rights.

**Export control** — This document as well as the item(s) described herein may be subject to export control regulations. Export might require a prior authorization from competent authorities.

**Non-automotive qualified products** — Unless this data sheet expressly states that this specific NXP Semiconductors product is automotive qualified, the product is not suitable for automotive use. It is neither qualified nor tested in accordance with automotive testing or application requirements. NXP Semiconductors accepts no liability for inclusion and/or use of non-automotive qualified products in automotive equipment or applications.

In the event that customer uses the product for design-in and use in automotive applications to automotive specifications and standards, customer (a) shall use the product without NXP Semiconductors' warranty of the product for such automotive applications, use and specifications, and (b) whenever customer uses the product for automotive applications beyond NXP Semiconductors' specifications such use shall be solely at customer's

own risk, and (c) customer fully indemnifies NXP Semiconductors for any liability, damages or failed product claims resulting from customer design and use of the product for automotive applications beyond NXP Semiconductors' standard warranty and NXP Semiconductors' product specifications.

**Translations** — A non-English (translated) version of a document is for reference only. The English version shall prevail in case of any discrepancy between the translated and English versions.

## 19.4 Trademarks

Notice: All referenced brands, product names, service names and trademarks are the property of their respective owners.

**I<sup>2</sup>C-bus** — logo is a trademark of NXP B.V.

## 20. Contact information

For more information, please visit: <http://www.nxp.com>

For sales office addresses, please send an email to: [salesaddresses@nxp.com](mailto:salesaddresses@nxp.com)



## 21. Contents

<b>1</b>	<b>General description</b> . . . . .	<b>1</b>	<b>18</b>	<b>Revision history</b> . . . . .	<b>46</b>
<b>2</b>	<b>Features and benefits</b> . . . . .	<b>1</b>	<b>19</b>	<b>Legal information</b> . . . . .	<b>47</b>
2.1	General . . . . .	1	19.1	Data sheet status . . . . .	47
2.2	I <sup>2</sup> C-bus mode . . . . .	1	19.2	Definitions . . . . .	47
<b>3</b>	<b>Quick reference data</b> . . . . .	<b>2</b>	19.3	Disclaimers . . . . .	47
<b>4</b>	<b>Ordering information</b> . . . . .	<b>2</b>	19.4	Trademarks . . . . .	48
<b>5</b>	<b>Block diagram</b> . . . . .	<b>3</b>	<b>20</b>	<b>Contact information</b> . . . . .	<b>48</b>
<b>6</b>	<b>Pinning information</b> . . . . .	<b>4</b>	<b>21</b>	<b>Contents</b> . . . . .	<b>49</b>
6.1	Pinning . . . . .	4			
6.2	Pin description . . . . .	4			
<b>7</b>	<b>Functional description</b> . . . . .	<b>5</b>			
7.1	Input stage . . . . .	5			
7.2	Output stage . . . . .	6			
7.3	Distortion (clip) detection . . . . .	6			
7.4	Output protection and short-circuit operation . . . . .	6			
7.5	SOAR protection . . . . .	6			
7.6	Speaker protection . . . . .	6			
7.7	Standby and mute operation . . . . .	7			
7.7.1	Legacy mode (pin ADSEL connected to ground) . . . . .	7			
7.7.2	I <sup>2</sup> C-bus mode . . . . .	7			
7.8	Start-up and shut-down sequence . . . . .	7			
7.9	Power-on reset and supply voltage spikes . . . . .	11			
7.10	Engine start and low voltage operation . . . . .	11			
7.11	Overvoltage and load dump protection . . . . .	14			
7.12	Thermal pre-warning and thermal protection . . . . .	14			
7.13	Diagnostics . . . . .	15			
7.14	Offset detection . . . . .	16			
7.15	DC load detection . . . . .	16			
7.16	AC load detection . . . . .	17			
7.17	I <sup>2</sup> C-bus diagnostic readout . . . . .	18			
<b>8</b>	<b>I<sup>2</sup>C-bus specification</b> . . . . .	<b>19</b>			
8.1	Instruction bytes . . . . .	20			
8.2	Data bytes . . . . .	22			
<b>9</b>	<b>Limiting values</b> . . . . .	<b>26</b>			
<b>10</b>	<b>Thermal characteristics</b> . . . . .	<b>27</b>			
<b>11</b>	<b>Characteristics</b> . . . . .	<b>27</b>			
<b>12</b>	<b>Performance diagrams</b> . . . . .	<b>32</b>			
<b>13</b>	<b>Application information</b> . . . . .	<b>39</b>			
13.1	PCB layout . . . . .	41			
<b>14</b>	<b>Test information</b> . . . . .	<b>42</b>			
14.1	Quality information . . . . .	42			
<b>15</b>	<b>Package outline</b> . . . . .	<b>43</b>			
<b>16</b>	<b>Mounting</b> . . . . .	<b>45</b>			
<b>17</b>	<b>Abbreviations</b> . . . . .	<b>45</b>			

Please be aware that important notices concerning this document and the product(s) described herein, have been included in section 'Legal information'.

© NXP B.V. 2013.

All rights reserved.

For more information, please visit: <http://www.nxp.com>

For sales office addresses, please send an email to: [salesaddresses@nxp.com](mailto:salesaddresses@nxp.com)

Date of release: 11 June 2013

Document identifier: TDA8594