

Series 970 PowerTrip™ Connectors and Accessories

Receptacle Connectors

970-003 Square Flange Receptacle

970-003 SQUARE FLANGE RECEPTACLES

Series 970 PowerTrip™ extreme environment receptacle connectors are intended for high current applications where size 8 AWG to size 1/0 AWG wires are used. These connectors feature high ampacity LouverBand contacts. Coupling threads are triple-start ACME type. EMI protected with ground spring on mating plug and splined backshell interface. Standard contacts are silver plated high conductivity copper alloy, or choose gold-plated contacts for improved corrosion protection. Fluorosilicone rubber gaskets and grommet provide watertight sealing. Contacts are packaged with connector.



- EMI Protected
- High Ampacity Contacts
- Submersible
- Harsh Environment

PRODUCT FACTS
2000 VAC Sea Level DWV Rating
-65°C to +200°C Operating Temperature
6 Feet Water Immersion, 48 Hours
65 dB min. Attenuation, up to 10GHz
2000 Cycles Mating Durability
MIL-S 901 Grade A High-Impact Shock
43 g Random Vibration

HOW TO ORDER

SERIES	SHELL MATL AND FINISH	SHELL SIZE - INSERT ARRANGEMENT					CONTACT TYPE AND PLATING	MOUNTING HOLE OPTION	KEY POSITION	
		Contact Arr.	Contact Size and Qty							
		#16	#12	#8	#4	#1/0				
970-003 Square Flange Panel Mount Receptacle with Crimp Contacts	ME Aluminum, Electroless Nickel Finish	18-2		2			P1 Pin Contacts, Silver Plating*	N Thru-Hole	-1 Position 1	
		18-4	2	2						
	MT Aluminum, Nickel-PTFE Finish		20-3		3		P2 Pin Contacts, Gold Plating	T Clinch Nuts Installed in Mounting Holes for Back Panel Mounting.	-2 Position 2	
			20-4		4					
			20-5	2	3					
			20-7	4	3					
	NF Aluminum, Olive Drab Cadmium		24-2			2	S1 Socket Contacts, Silver Plating*		-3 Position 3	
			24-3			3				
			24-5		5					
			24-6	4	2					
	ZR Aluminum, Black Zinc-Nickel Finish		24-A6	3	3		S2 Socket Contacts, Gold Plating		-4 Position 4	
			28-4		4					
	Z1 Passivated Stainless Steel		28-9	5	4		A Pin Connector, without Contacts		-5 Position 5	
			32-2							2
			32-3							3
			32-4		2	2				
		32-5			5					
		32-6	3		3					
		36-4			4					
		40-5			5					
Sample Part Number										
970-003	MT	24-5					P1	N	-1	

* Size 12 and 16 contacts are gold-plated. Size 8, 4 and 1/0 are silver plated.

Series 970 PowerTrip™ Connectors and Accessories
 Receptacle Connectors
 970-003 Square Flange Receptacle



Receptacle Connectors

970-003 SQUARE FLANGE RECEPTACLE

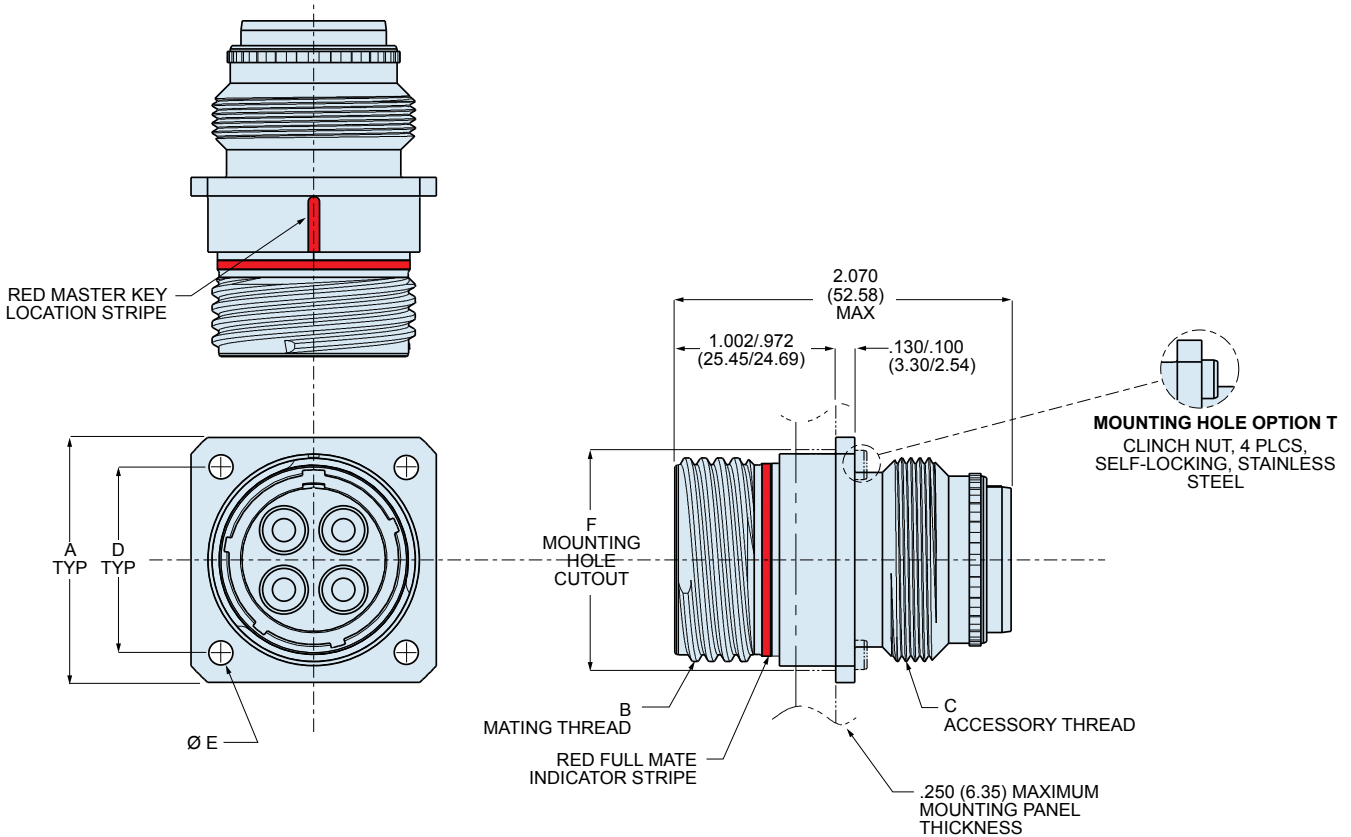

D

DIMENSIONS											
Shell Size	A		B Mating Thread	C Accessory Thd	D		Ø E		E Clinch Nut Thd	Ø F	
	In.	mm.			In.	mm.	In.	mm.		In.	mm.
18	1.383	35.13	1.125-.1P-.3L-TS-2A	1.125-18 UNEF-2A	1.015	25.78	.146	3.71	6-32 UNC-2B	1.187	30.15
20	1.508	38.30	1.250-.1P-.3L-TS-2A	1.250-18 UNEF-2A	1.140	28.96	.146	3.71	6-32 UNC-2B	1.374	34.90
24	1.718	43.64	1.500-.1P-.3L-TS-2A	1.4375-18 UNEF-2A	1.281	32.54	.146	3.71	6-32 UNC-2B	1.562	39.67
28	2.138	54.31	1.750-.1P-.3L-TS-2A	1.8125-16 UN-2A	1.568	39.83	.170	4.32	8-32 UNC-2B	1.835	46.61
32	2.328	59.13	2.000-.1P-.3L-TS-2A	2.0625-16 UNS-2A	1.734	44.04	.170	4.32	8-32 UNC-2B	2.093	53.16
36	2.578	65.48	2.250-.1P-.3L-TS-2A	2.250-16 UN-2A	1.984	50.39	.170	4.32	8-32 UNC-2B	2.302	58.47
40	2.828	71.83	2.500-.1P-.3L-TS-2A	2.500-16 UN-2A	2.234	56.74	.170	4.32	8-32 UNC-2B	2.562	65.07

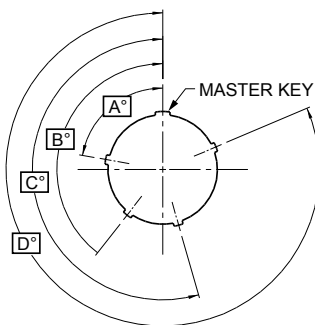

KEY POSITIONS				
Position	A°	B°	C°	D°
1	80	142	196	293
2	135	170	200	310
3	49	169	200	244
4	66	140	200	257
5	62	145	180	280
6	79	153	197	272