



800-013

**Series 80 Mighty Mouse Hermetic Receptacles
with UN Mating Thread How to Order Information**



Series 800 Hermetic Receptacles feature 304L stainless steel shells, fused vitreous glass insulators and Alloy 52 iron alloy contacts.

1 X 10⁻⁷ cc/second maximum helium leak rate.

Three Shell Styles: solder mount, jam nut or square flange.

Solder Cup Contacts for wire attachment, or **PC Tail Contacts** for attachment to flexible or rigid circuits.

C

Series 800 Hermetic

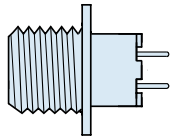
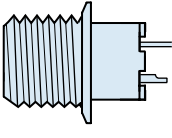
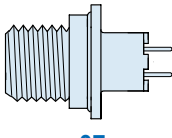
HOW TO ORDER					
Sample Part Number					
800-013	-07	Z1	7-10	P	Z
Series	Shell Style	Shell Material / Finish	Shell Size- Insert Arrangement	Contact Type	Shell Key Position
800-013 Hermetic Receptacle	 -02 Square Flange	Z1 Stainless Steel / Passivated ZL Stainless Steel / Nickel Plated *Titanium and Inconel® shell materials are available. Consult factory for ordering information.	See Page C-4 for Contact Arrangements	P Pin, Solder Cup	N Normal
	 -03 Solder Mount			C Pin, PC Tail	X Pos. X
	 -07 Jam Nut			S Socket, Solder Cup D Sockets, PC Tail	Y Pos. Y Z Pos. Z

Dimensions in Inches (millimeters) are subject to change without notice.

Series 800 Mighty Mouse Hermetic Receptacles
with UN Mating Thread
Torque Values and Panel Cutouts



SERIES 800 RECOMMENDED TORQUE VALUES												
Shell Size	Coupling Torque				Jam Nut				Backshell			
	In-Lbs.		N-m		In-Lbs.		N-m		In-Lbs.		N-m	
	Min.	Max.	Min.	Max.	Min.	Max.	Min.	Max.	Min.	Max.	Min.	Max.
5	13	17	1.5	1.9	20	25	2.2	2.8	13	17	1.5	1.9
6	18	22	2.0	2.5	20	25	2.2	2.8	18	22	2.0	2.5
7	20	25	2.3	2.8	20	25	2.2	2.8	30	40	3.4	4.5
8	30	40	3.4	4.5	20	25	2.2	2.8	30	40	3.4	4.5
9	30	40	3.4	4.5	25	30	2.8	3.3	35	45	4.0	5.1
10	35	45	4.0	5.1	25	30	2.8	3.3	35	45	4.0	5.1
12	35	45	4.0	5.1	25	30	2.8	3.3	35	45	4.0	5.1

HERMETIC LEAK RATE MOD CODES	
Designator	Required Leak Rate
-585A	1 x 10 ⁻¹⁰ cc Helium per second
-585B	1 x 10 ⁻⁹ cc Helium per second
-585C	1 x 10 ⁻⁸ cc Helium per second

SERIES 800 PANEL CUTOUTS				
Shell Size	A Flat		øB	
	In.	mm.	In.	mm.
5	.302 / .298	7.67 / 7.57	.318	8.08
6	.365 / .361	9.27 / 9.17	.386	9.80
7	.424 / .420	10.77 / 10.67	.449	11.40
8	.486 / .482	12.34 / 12.24	.510	12.95
9	.543 / .539	13.79 / 13.69	.574	14.58
10	.617 / .613	15.67 / 15.57	.635	16.12
12	.725 / .721	18.42 / 18.31	.760	19.30

Dimensions in Inches (millimeters) are subject to change without notice.



800-013-02 and 800-013-03
Series 800 Mighty Mouse Hermetic Receptacles
Square Flange Mount with UN Mating Thread
Connector Dimensions

800-013-02 Square Flange Dimensions

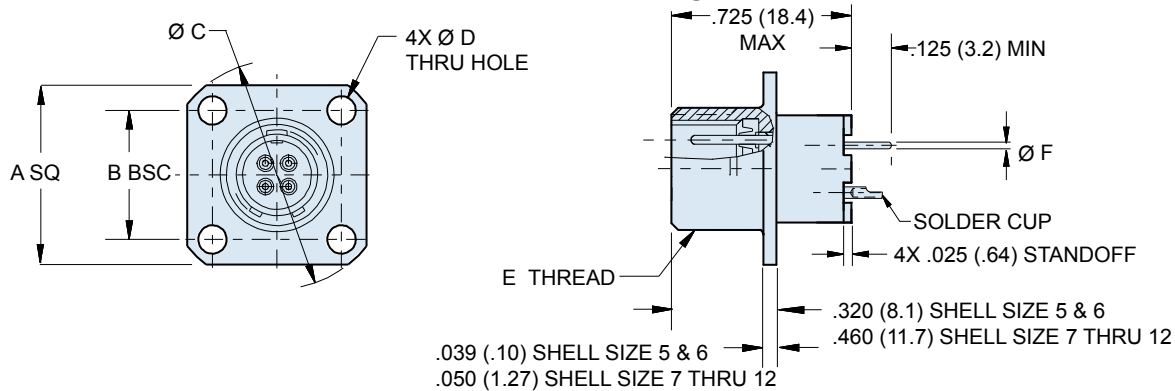

800-013-02 SQUARE FLANGE HERMETIC RECEPTACLE DIMENSIONS

Shell Size	A SQ		B BSC		Ø C		Ø D		E Threads Mating	Ø F PC TAIL DIA. ± .002 (0.05)
	In.	mm.	In.	mm.	In.	mm.	In.	mm.		
5	.527	13.39	.363	9.22	.680	17.27	± .005	± 0.13	.3125-28 UN-2A	Size #23 .020 (0.51) Size #20 .026 (0.66) Size #16 .062 (1.57) Size #12 .094 (2.34)
6	.588	14.92	.423	10.74	.750	19.05	.094	2.39	.5000-32 UN-2A	
7	.650	16.51	.483	12.27	.830	21.08	.096	2.44	.4375-28 UNEF-2A	
8	.710	18.03	.542	13.77	.938	23.83	.091	2.31	.5000-32 UN-2A	
9	.938	23.83	.719	18.26	1.250	31.75	.130	3.30	.5625-32 UN-2A	
10	.938	23.83	.719	18.26	1.250	31.75			.6250-32 UN-2A	
12	1.031	26.19	.812	20.62	1.375	34.93			.7500-28 UN-2A	

800-013-03 Solder Mount Dimensions

Shell Size 5 and 6

Shell Size 7 thru 12

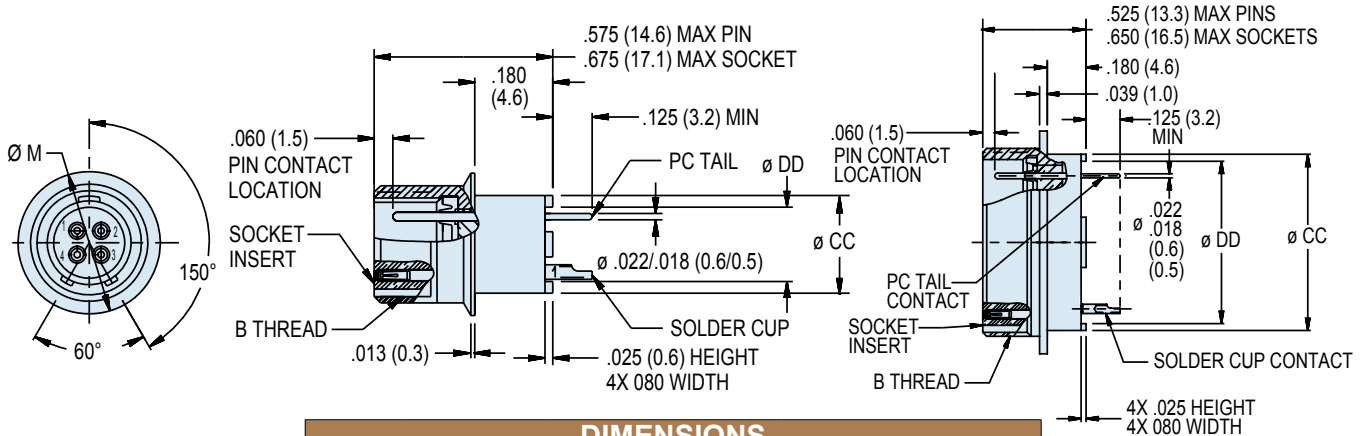

DIMENSIONS

Shell Size	Ø A		B Threads	Ø C PC TAIL DIA. ± .002 (0.05)
	In.	mm.		
5	.400	10.16	.3125-28 UN-2A	Size #22 .020 (0.51) Size #20 .026 (0.66) Size #16 .062 (1.57) Size #12 .094 (2.34)
6	.455	11.56	.3750-28 UN-2A	
7	.520	13.21	.4375-28 UNEF-2A	
8	.650	16.51	.5000-32 UN-2A	
9	.764	19.41	.5625-32 UN-2A	
10	.775	19.69	.6250-32 UN-2A	
12	.858	21.79	.7500-28 UN-2A	

800-013-07

Series 800 Mighty Mouse Hermetic Receptacles
Jam Nut Mount with UN Mating Thread
Hermetic Connector Dimensions



Series 80
Mighty Mouse

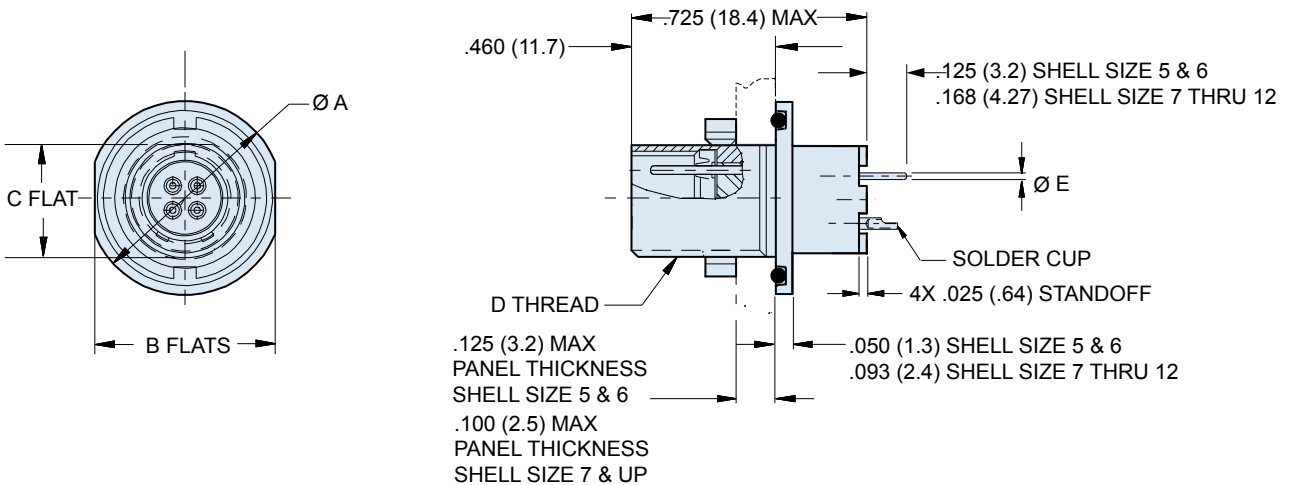

C

DIMENSIONS								
Shell Size	Ø A		Ø B		C		D Threads Mating	Ø E PC TAIL DIA. $\pm .002$ (0.05)
	In.	mm.	In.	mm.	In.	mm.		
5	.541	13.74	.500	12.70	.285	7.24	.3125-28 UN-2A	Size #23 .020 (0.51) Size #20 .026 (0.66) Size #16 .062 (1.57) Size #12 .094 (2.34)
6	.610	15.49	.562	14.27	.352	8.94	.3750-28 UN-2A	
7	.670	17.02	.635	16.13	.411	10.44	.4375-28 UNEF-2A	
8	.775	19.69	.735	18.67	.473	12.01	.5000-32 UN-2A	
9	.875	22.23	.806	20.47	.530	13.46	.5625-32 UN-2A	
10	.980	24.89	.940	23.88	.604	15.34	.6250-32 UN-2A	
12	1.062	26.97	.986	25.04	.712	18.08	.7500-28 UN-2A	

SERIES 800 KEY POSITIONS	
Plug	Receptacle
Key Position	Key Rotation
Normal (N)	150°
X	140°
Y	130°
Z	120°
Shell size 5 and 6: master key is located at top dead center for normal (N) position. Shell size 7 thru 12: master key is rotated 90° from TDC.	

SERIES 800 PANEL CUTOUTS				
Shell Size	A Flat		ØB	
	In.	mm.	In.	mm.
5	.302 / .298	7.67 / 7.57	.318	8.08
6	.365 / .361	9.27 / 9.17	.386	9.80
7	.424 / .420	10.77 / 10.67	.449	11.40
8	.486 / .482	12.34 / 12.24	.510	12.95
9	.543 / .539	13.79 / 13.69	.574	14.58
10	.617 / .613	15.67 / 15.57	.635	16.12
12	.725 / .721	18.42 / 18.31	.760	19.30

Dimensions in Inches (millimeters) are subject to change without notice.

© 2013 Glenair, Inc.

U.S. CAGE Code 06324

Printed in U.S.A.