

797-087

Series 79 Micro-Crimp Hermetic Receptacle
Pin Contacts with P.C. Tails
Size H-66 Only

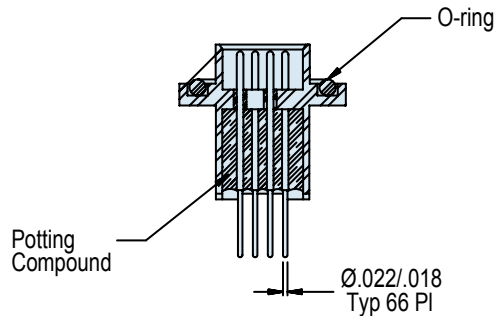

Series 79
Micro-Crimp

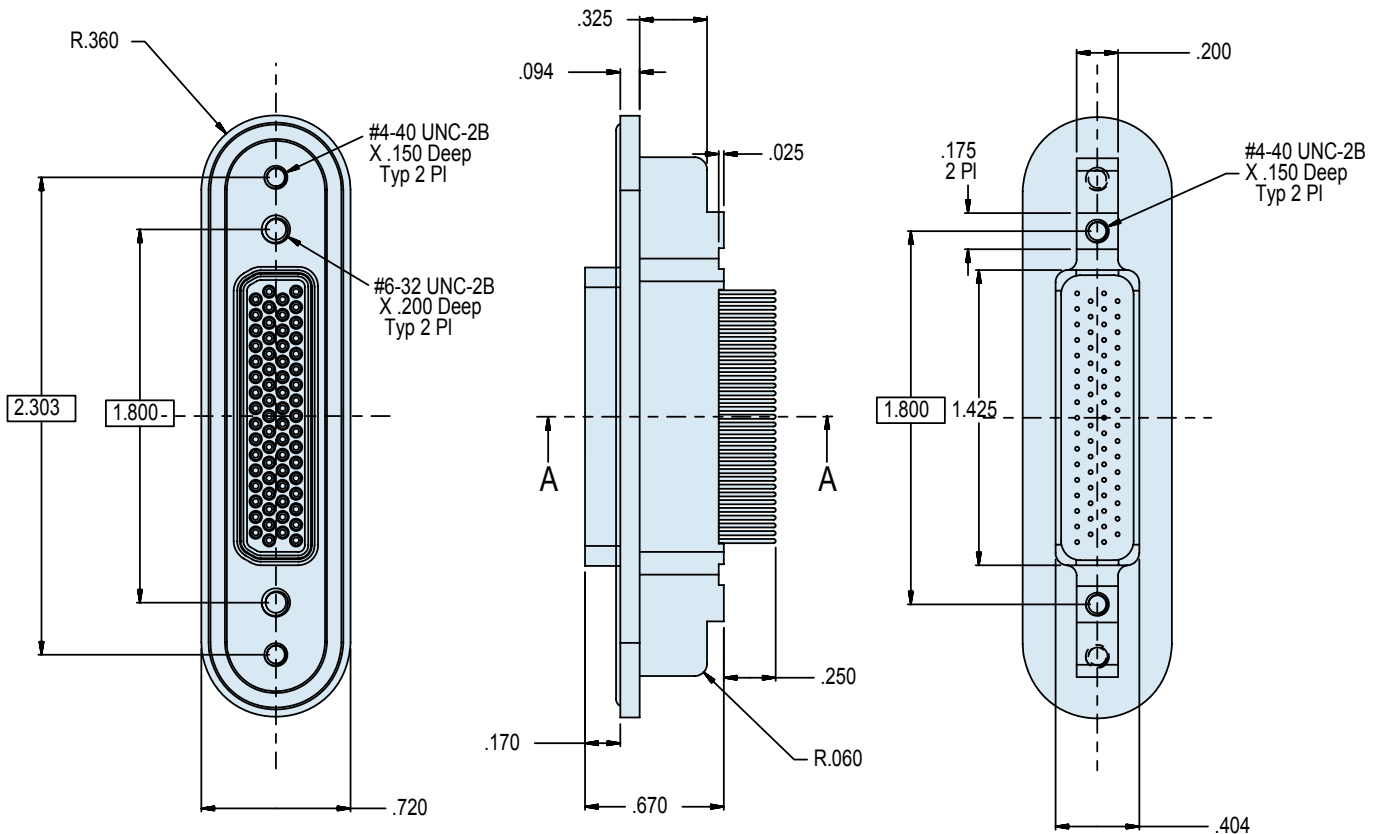
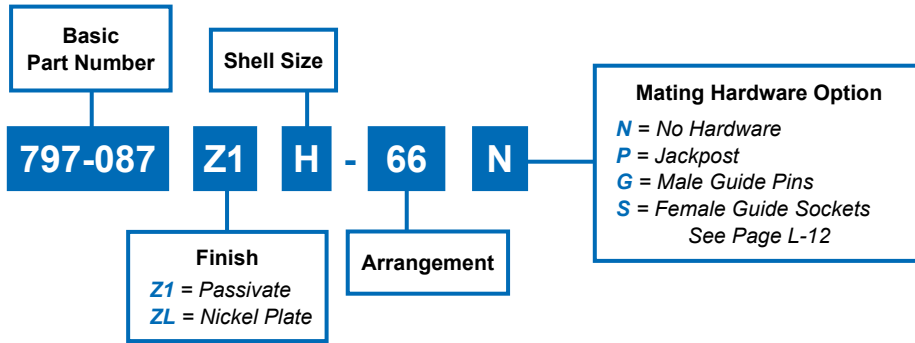

L



797-087
Series 79 Micro-Crimp Hermetic Receptacle
Pin Contacts with P.C. Tails
Size H-66 Only

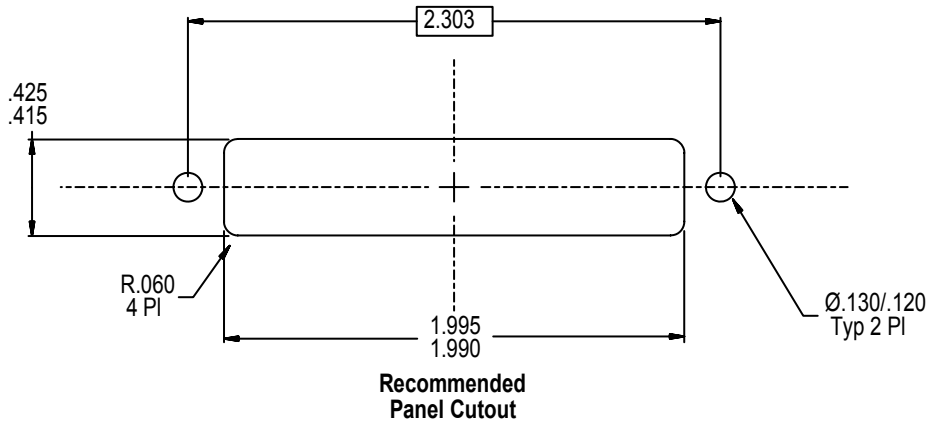

L

APPLICATION NOTES

- | | |
|---|---|
| <p>1. Material/Finish:
 Shell* - 300 Series CRES/passivate or 300 Series CRES/Nickel Plate
 Contacts - Nickel iron alloy/gold plate
 Insulator - Full glass/N.A.
 Seals - Fluorosilicone blend/N.A.
 Potting - Epoxy/N.A.
 *Consult factory for other shell finishes and O-Ring materials.</p> | <p>2. Metric dimensions (mm) are indicated in parentheses.</p> <p>3. Test Criteria:
 Hermeticity - $<1 \times 10^{-7}$ scc He/sec @1 ATM Delta
 DWV - 500 VAC pin-to-pin and pin-to-shell w/o breakdown
 I.R. - 5,000 megohms minimum @500 VDC</p> <p>4. Glenair 797-087 is designed to intermate with any Glenair 790 series plug having an H-66S (Socket) arrangement.</p> |
|---|---|