

M39029/58-360 and M39029/56-348
850-002-22-360 and 850-001-22-348
Standard Duty Electrical Pin and Socket Contacts



D38999 Type
RJ45 Connectors

A

SIZE #22 PIN AND SOCKET CONTACTS FOR USE WITH SUPERSEAL™ 233-304 AND 233-301 CONNECTORS



Pin Contact

	Mating End Size	Wire Accomodation	Military Part Number	Glenair Part Number
Pin	22	22-28 AWG	M39029/58-360	850-002-22-360
Socket	22	22-28 AWG	M39029/56-348	850-001-22-348

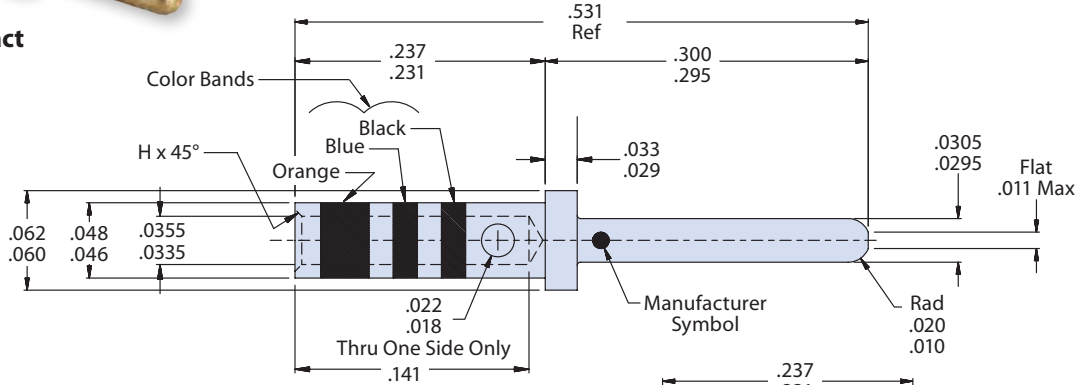

Socket Contact

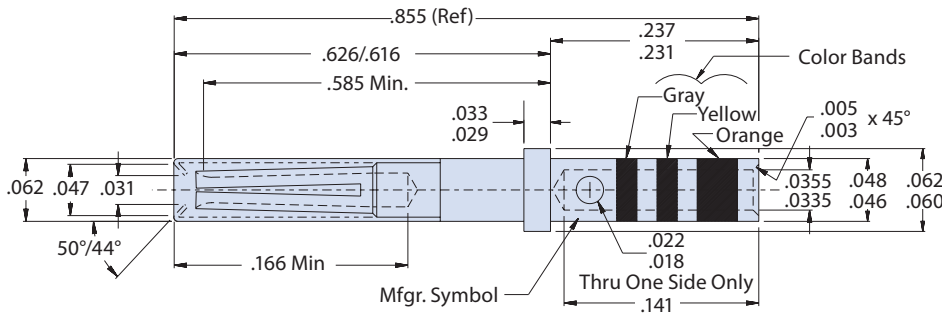
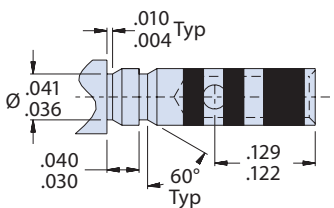
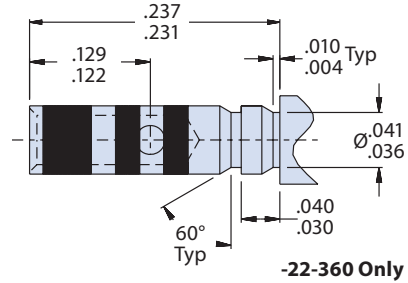

-22-348 Only

Termination Tools							
Size 22	Part Number	Military Number	AWG Handling	Crimp Tool	Positioner	Insertion Tool	Extraction Tool
Pin	850-002-22-360	M39029/58-360	22, 24, 26, 28	M22520/2-01 M22520/7-01	M22520/2-09 M22520//7-07	M81969/14-01 M81969/8-01	M81969/14-01 M81969/8-02
Socket	850-001-22-348	M39029/56-348	22, 24, 26, 28	M22520/2-01 M22520/7-01	M22520/2-07 M22520//7-05	M81969/14-01 M81969/8-01	M81969/14-01 M81969/8-02