

**Series 801 Mighty Mouse Double-Start ACME Threads
In-Line Receptacle Connector Dimensions
801-009-01 and 801-010-01**

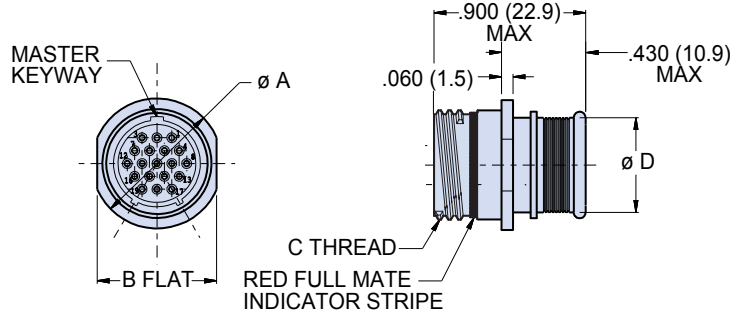

**Integral Band Platform
801-009-01**

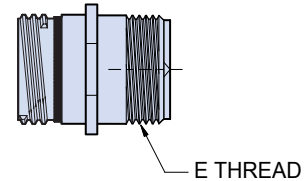

**Accessory Thread
801-010-01**

Dimensions								
Shell Size	Ø A		B Flat		C Thread	Ø D		E Thread UNEF-2A
	In.	mm.	In.	mm.		In.	mm.	
5	.355	9.02	.325	8.13	.3125-.05P-.1L-2A	.245	6.22	.250-32
6	.415	10.54	.385	9.78	.375-.05P-.1L-2A	.290	7.37	.3125-32
7	.480	12.19	.445	11.30	.4375-.05P-1L2A	.390	9.91	.4375-28
8	.540	13.72	.510	12.95	.5000-.05P-1L2A	.445	11.30	.5000-28
9	.605	15.37	.575	14.61	.5625-.05P-.1L-2A	.500	12.70	.5625-24
10	.665	16.89	.635	16.13	.6250-.05P-1L2A	.560	14.22	.6250-24
13	.855	21.72	.825	20.96	.8125-.1P-.2L-2a	.650	16.51	.6875-24
16	1.040	26.42	1.010	25.65	1.000-.1P-.2L-2A	.805	20.44	.9375-20
17	1.110	28.19	1.070	27.18	1.062-.1P-.2L-2A	.850	21.59	.9375-20
21	1.405	35.69	1.385	35.18	1.3125-.1P-.2L-2A	1.110	28.19	1.1875-18

Key Positions		
	A°	B°
A	150°	210°
B	75°	210°
C	95°	230°
D	140°	275°
E	75°	275°
F	95°	210°