

# Series 802 "Aqua Mouse" Submersible Plug Connector Dimensions

## 802-008-06 and 802-009-06

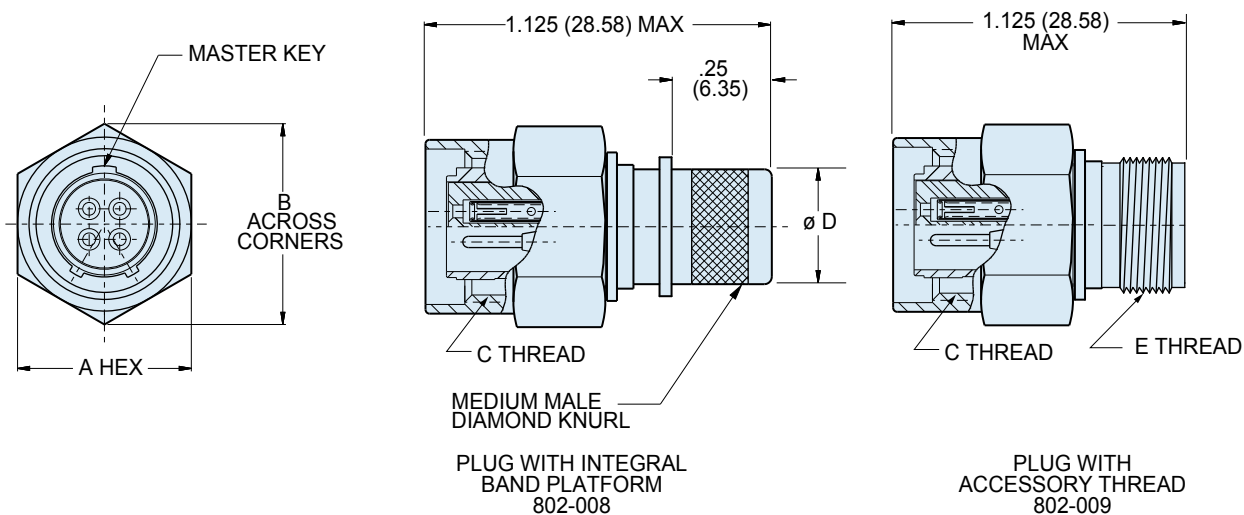

Mighty Mouse  
Fiber Optic



D

Dimensions								
Shell Size	A Hex		B Max.		C Mating Threads	Ø D		E Threads Accessory
	In.	mm.	In.	mm.		In.	mm.	
5	.500	12.70	.560	14.22	.438-28 UNEF	.232	5.90	.2500-32 UNEF-2A
6	.625	15.88	.720	18.29	.562-20 UN	.312	7.92	.3125-32 UNEF-2A
7	.688	17.48	.780	19.81	.625-20 UN	.375	9.53	.4375-28 UNEF-2A
8	.750	19.05	.860	21.84	.687-20 UN	.438	11.13	.5000-28 UNEF-2A
9	.812	20.62	.930	23.62	.750-20 UNEF	.500	12.70	.5625-24 UNEF-2A
10	.875	22.23	1.000	25.40	.812-20 UNEF	.562	14.27	.6250-24 UNEF-2A
12	.938	23.83	1.060	26.92	.875-20 UNEF	.656	16.66	.6875-24 UNEF-2A
14	1.125	28.58	1.250	31.75	1.062-20 UN	.812	20.62	.8750-20 UNEF-2A
15	1.188	30.18	1.320	33.53	1.125-20 UN	.885	22.40	.9375-20 UNEF-2A
21	1.562	39.67	1.700	43.18	1.437-20 UN	1.188	30.18	1.2500-18 UNEF-2A

Series 802 Plug Key Positions		
Key Position	Key Rotation	
	A°	B°
Normal (A)	150°	210°
B	75°	210°
C	95°	230°
D	140°	275°