

Series 800 Mighty Mouse with UN Mating Thread Crimp Receptacle Ordering Information

800-010 and 800-011



In-Line



Rear Panel Jam Nut



Square Flange

Integral Band Platform for direct attachment of a cable shield using a **BAND-IT®** strap. Install a boot, or overmold onto the band platform. An accessory thread is available for attaching strain reliefs and backshells.

Three Shell Options: Jam nut with o-ring for rear panel mounting, square flange or in-line receptacle for free-hanging cables.

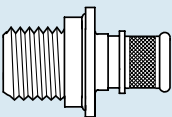
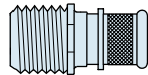
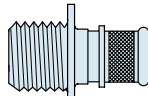
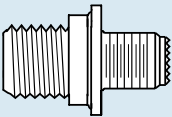
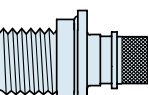
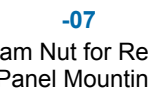
HOW TO ORDER					
Sample Part Number					
800-011	-01	M	6-4	P	N
Series	Shell Style	Shell Material / Finish	Shell Size- Insert Arrangement	Contact Type	Shell Key Position
 800-010 Receptacle with Banding Platform	 -01 In-Line	C Aluminum / Black Anodize (Non-Conductive) RoHS Compliant	SEE CONTACT ARRANGEMENTS PAGE C-2	Connector supplied with contacts P Pin	N Normal
	 -02 Square Flange for Front or Rear Mounting	M Aluminum / Electroless Nickel RoHS Compliant		S Socket	Connector supplied without contacts Y Pos. Y
 800-011 Receptacle with Accessory Thread	 -02 Square Flange for Front or Rear Mounting	NF Aluminum / Cadmium with Olive Drab Chromate		A Pin Connector, less contacts	Z Pos. Z
	 -07 Jam Nut for Rear Panel Mounting	ZN Aluminum / Zinc-Nickel with Olive Drab Chromate		B Socket Connector, less contacts	Connectors with contacts are supplied with signal and/or power crimp contacts. These contacts are not installed. Coaxial contacts and non-standard signal contacts are ordered separately.
		ZNU Aluminum / Zinc-Nickel with Black Chromate			
	MT Aluminum / Nickel-PTFE RoHS Compliant				
		Z1 Stainless Steel / Passivated RoHS Compliant			

Dimensions in inches (millimeters) and are subject to change without notice.



Series 800 Mighty Mouse with UN Mating Thread Jam Nut Crimp Receptacle Dimensions

800-010-07 and 800-011-07

Integral Band Platform 800-010-07

Accessory Thread 800-011-07

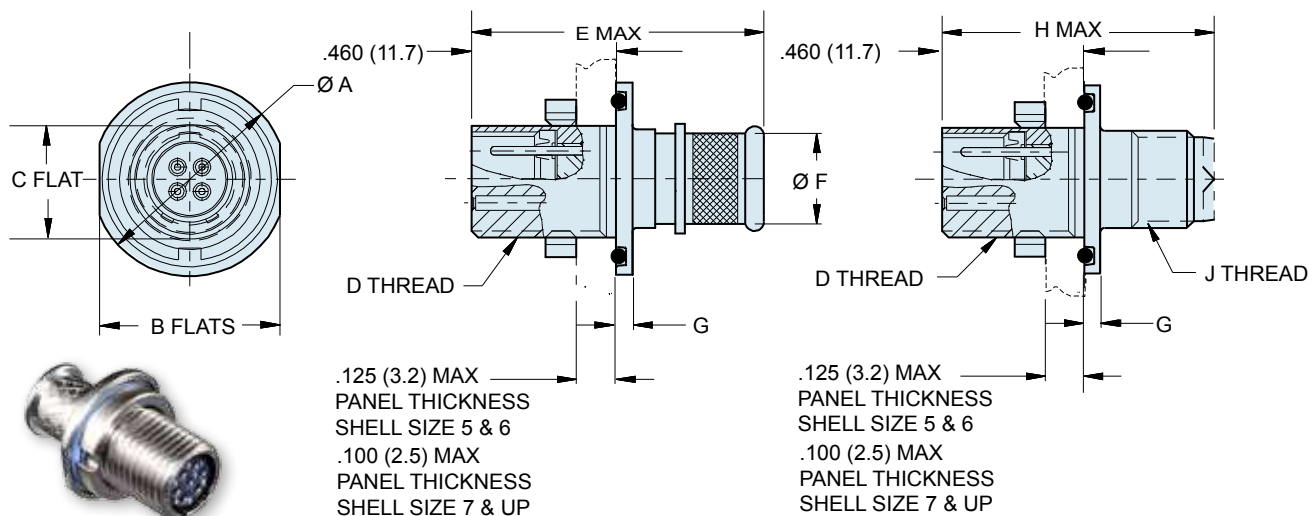

DIMENSIONS

Shell Size	Ø A		B		C		D Threads Mating	E Max.		Ø F		Ø G		H Max.		J Threads Accessory
	In.	mm.	In.	mm.	In.	mm.		In.	mm.	In.	mm.	In.	mm.	In.	mm.	
5	.541	13.74	.500	12.70	.285	7.24	.3125-28 UN-2A	.875	22.22	.230	5.84	.051	1.30	.850	21.59	.250-32 UNEF-2A
6	.610	15.49	.562	14.27	.352	8.94	.3750-28 UN-2A	.875	22.22	.286	7.26	.051	1.30	.850	21.59	.3125-32 UNEF-2A
7	.670	17.02	.635	16.13	.411	10.44	.4375-28 UNEF-2A	.875	22.22	.390	9.91	.093	2.36	.850	21.59	.4375-28 UNEF-2A
8	.775	19.69	.735	18.67	.473	12.01	.5000-32 UN-2A	.875	22.22	.445	11.30	.093	2.36	.850	21.59	.5000-28 UNEF-2A
9	.875	22.23	.806	20.47	.530	13.46	.5625-32 UN-2A	.875	22.22	.500	12.70	.093	2.36	.850	21.59	.5625-24 UNEF-2A
10	.980	24.89	.940	23.88	.604	15.34	.6250-32 UN-2A	.875	22.22	.565	14.35	.093	2.36	.850	21.59	.6250-24 UNEF-2A
12	1.062	26.97	.986	25.04	.712	18.08	.7500-28 UN-2A	.875	22.22	.650	16.51	.093	2.36	.850	21.59	.6875-24 UNEF-2A

SERIES 800 PANEL CUTOUTS

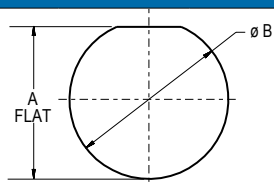

Shell Size	A Flat		Ø B	
	In.	mm.	In.	mm.
5	.295/.299	7.49/7.59	.317/.327	8.05/8.30
6	.358/.362	9.09/9.19	.380/.390	9.65/9.91
7	.424/.428	10.77/10.87	.442/.452	11.23/11.48
8	.479/.483	12.16/12.26	.505/.515	12.83/13.08
9	.537/.541	13.64/13.74	.567/.577	14.40/14.66
10	.610/.614	15.49/15.59	.630/.640	16.00/16.26
12	.717/.721	18.21/18.31	.755/.765	19.18/19.43

SERIES 800 KEY POSITIONS

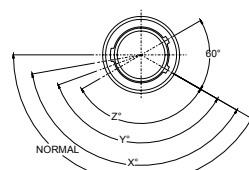

Plug

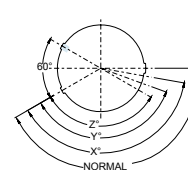

Receptacle

Key Position	Key Rotation
Normal (N)	150°
X	140°
Y	130°
Z	120°

Shell size 5 and 6: master key is located at top dead center for normal (N) position. Shell size 7 thru 12: master key is rotated 90° from TDC.

Dimensions in inches (millimeters) and are subject to change without notice.

Series 800 Mighty Mouse with UN Mating Thread Square Flange Crimp Receptacle Dimensions 800-010-02 and 800-011-02

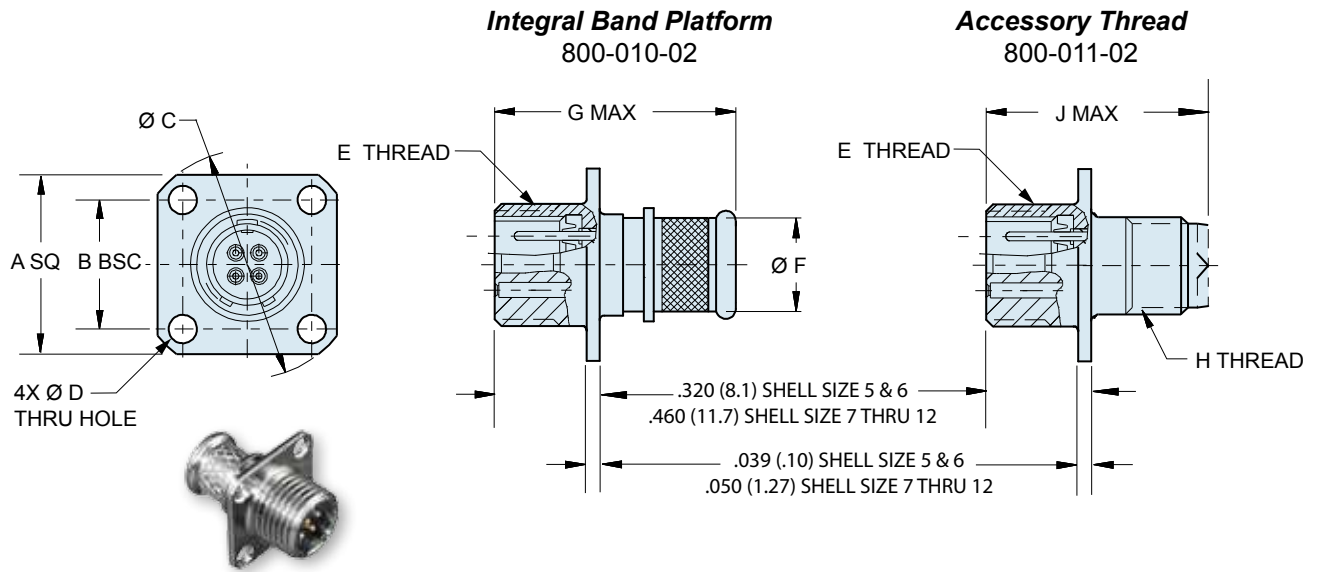

DIMENSIONS

Shell Size	A SQ		B		Ø C		Ø D		E Threads Mating	Ø F		G Max.		H Threads Accessory		J Max.	
	In.	mm.	In.	mm.	In.	mm.	In.	mm.		In.	mm.	In.	mm.	In.	mm.	In.	mm.
5	.527	13.39	.363	9.22	.680	17.27	.094	2.39	.3125-28 UN-2A	.230	5.84	.750	19.05	.250-32 UNEF-2A	.725	18.42	
6	.588	14.92	.423	10.74	.750	19.05	.094	2.39	.3750-28 UN-2A	.286	7.26	.750	19.05	.3125-32 UNEF-2A	.725	18.42	
7	.650	16.51	.483	12.27	.830	21.08	.128	3.25	.4375-28 UNEF-2A	.390	9.91	.825	20.96	.4375-28 UNEF-2A	.800	20.32	
8	.710	18.03	.542	13.77	.938	23.83	.128	3.25	.5000-32 UN-2A	.445	11.30	.825	20.96	.5000-28 UNEF-2A	.800	20.32	
9	.938	23.83	.719	18.26	1.250	31.75	.128	3.25	.5625-32 UN-2A	.500	12.70	.825	20.96	.5625-24 UNEF-2A	.800	20.32	
10	.938	23.83	.719	18.26	1.250	31.75	.128	3.25	.6250-32 UN-2A	.565	14.35	.825	20.96	.6250-24 UNEF-2A	.800	20.32	
12	1.031	26.19	.812	20.62	1.375	34.93	.128	3.25	.7500-28 UN-2A	.650	16.51	.825	20.96	.6875-24 UNEF-2A	.800	20.32	

SERIES 800 KEY POSITIONS

Key Position	Key Rotation		
Normal (N)	150°	<p style="text-align: center;">Plug Key Position</p>	<p style="text-align: center;">Receptacle Key Position</p>
X	140°		
Y	130°		
Z	120°		
<p>Shell size 5 and 6: master key is located at top dead center for normal (N) position. Shell size 7 thru 12: master key is rotated 90° from TDC.</p>			

Dimensions in inches (millimeters) and are subject to change without notice.



Series 800 Mighty Mouse with UN Mating Thread In-Line Crimp Receptacle Dimensions 800-010-01 and 800-011-01

Integral Band Platform
800-010-01

Accessory Thread
800-011-01

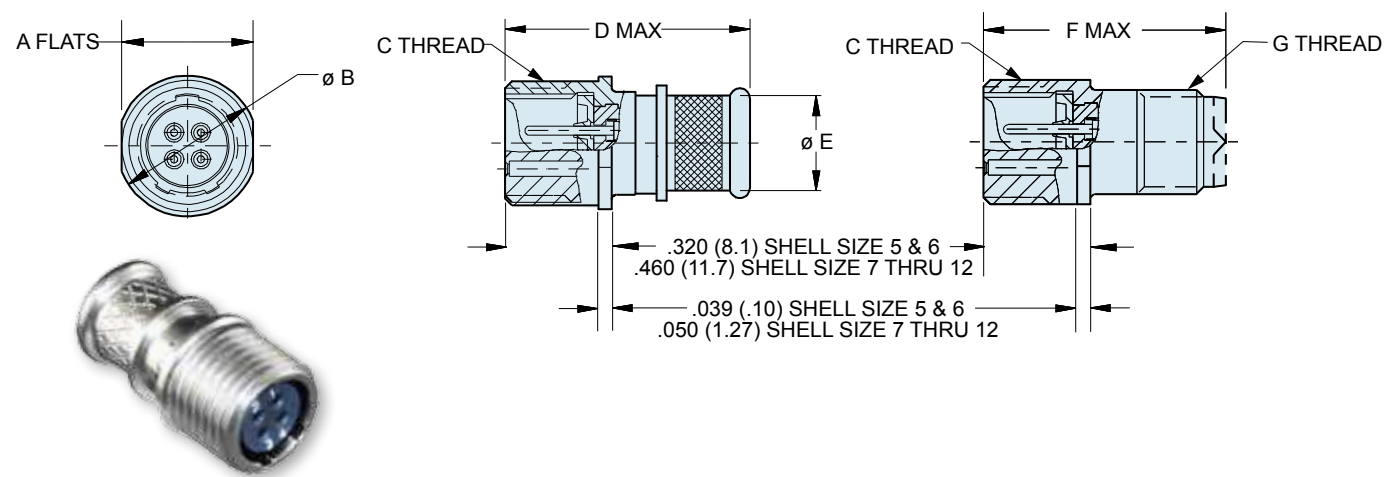

DIMENSIONS

Shell Size	A		Ø B		C Threads Mating	D Max.		Ø E		F Max.		G Threads Accessory
	In.	mm.	In.	mm.		In.	mm.	In.	mm.	In.	mm.	
5	.312	7.92	.355	9.02	.3125-28 UN-2A	.750	19.05	.230	5.84	.725	18.42	.250-32 UNEF-2A
6	.375	9.53	.400	10.16	.3750-28 UN-2A	.750	19.05	.286	7.26	.725	18.42	.3125-32 UNEF-2A
7	.445	11.30	.490	12.45	.4375-28 UNEF-2A	.825	20.96	.390	9.91	.800	20.32	.4375-28 UNEF-2A
8	.550	13.97	.600	15.24	.5000-32 UN-2A	.825	20.96	.445	11.30	.800	20.32	.5000-28 UNEF-2A
9	.613	15.57	.663	16.84	.5625-32 UN-2A	.825	20.96	.500	12.70	.800	20.32	.5625-24 UNEF-2A
10	.675	17.15	.725	18.42	.6250-32 UN-2A	.825	20.96	.565	14.35	.800	20.32	.6250-24 UNEF-2A
12	.800	20.32	.850	21.59	.7500-28 UN-2A	.825	20.96	.650	16.51	.800	20.32	.6875-24 UNEF-2A

SERIES 800 KEY POSITIONS

Key Position	Key Rotation
Normal (N)	150°
X	140°
Y	130°
Z	120°

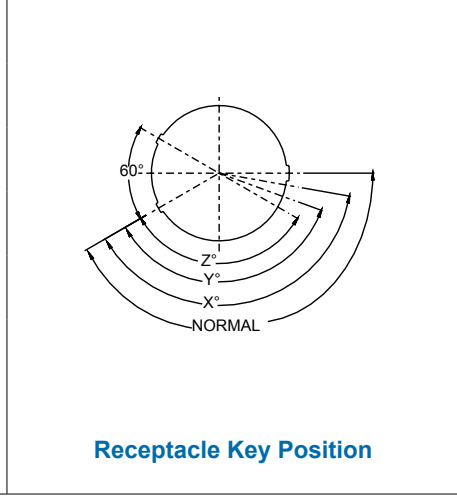
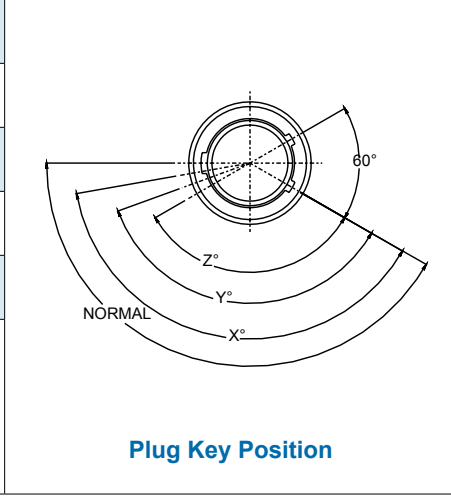

Shell size 5 and 6: master key is located at top dead center for normal (N) position. Shell size 7 thru 12: master key is rotated 90° from TDC for normal position.

Dimensions in inches (millimeters) and are subject to change without notice.