

Series 800 Mighty Mouse with UN Mating Thread Printed Circuit Board Receptacle Ordering Info

800-012-02 and 800-012-07



Series 800 PCB Receptacle

Printed Circuit Board/Solder Cup Receptacles feature low profile shells for minimum protrusion inside enclosures and integral board standoffs. Contacts are non-removable.

Water Immersion, Unmated

Specify **800-012** connectors for applications where open face water immersion is not a requirement. For MIL-STD-810 Method 512G immersion requirements, specify **800-040** watertight connectors. These 800-040 connectors are specially sealed ("MOD-518") and are 100% tested to maintain a helium leak rate of 1×10^{-4} cc/second at one atmosphere pressure differential from -40C to +70C.

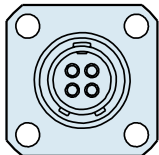
HOW TO ORDER					
Sample Part Number					
800-012	-07	M	7-10	P	Z
Series	Shell Style	Shell Material / Finish	Shell Size- Insert Arrangement	Contact Type	Shell Key Position
800-012 Receptacle for Solder Cup or PCB Termination, with Standard Epoxy Potting	 -02 Square Flange	C Aluminum / Black Anodize (Non-Conductive) RoHS Compliant M Aluminum / Electroless Nickel RoHS Compliant	SEE CONTACT ARRANGEMENTS PAGE C-2	P Pin S Socket	N Normal X Pos. X

Dimensions in inches (millimeters) and are subject to change without notice.

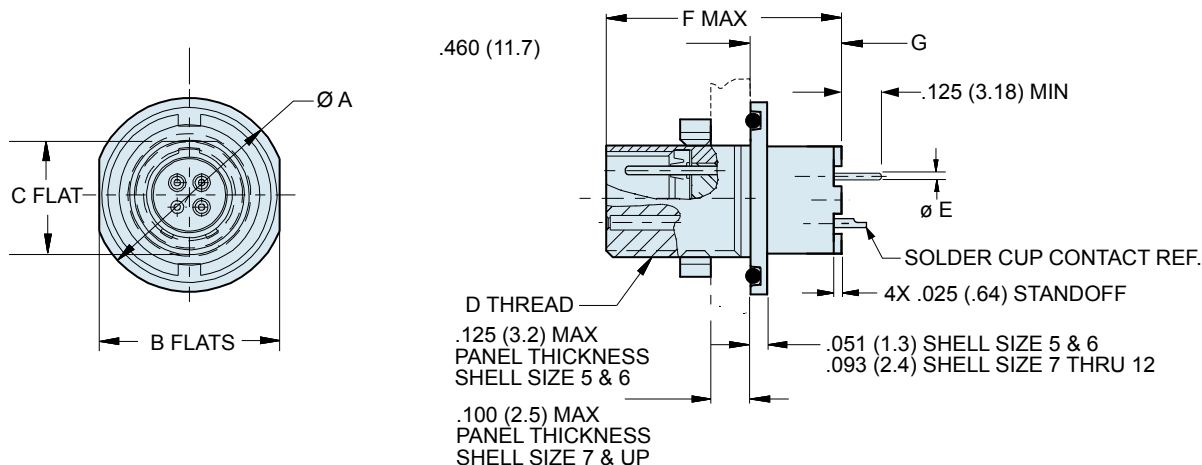

DIMENSIONS

Shell Size	Ø A		Ø B		C		D Threads Mating	Ø E Tail Dia.	F Max		G	
	In.	mm.	In.	mm.	In.	mm.			In.	mm.	In.	mm.
5	.541	13.74	.500	12.70	.285	7.24	.3125-28 UN-2A	#23 .018/.022 (0.46/0.56)	.725	18.42	.247	6.27
6	.610	15.49	.562	14.27	.352	8.94	.3750-28 UN-2A		.725	18.42	.247	6.27
7	.670	17.02	.635	16.13	.411	10.44	.4375-28 UNEF-2A	#20 .024/.028 (0.61/0.71)	.700	17.78	.205	5.21
8	.775	19.69	.735	18.67	.473	12.01	.5000-32 UN-2A		.700	17.78	.205	5.21
9	.875	22.23	.806	20.47	.530	13.46	.5625-32 UN-2A	#16 .060/.064 (1.52/1.63)	.700	17.78	.205	5.21
10	.980	24.89	.940	23.88	.604	15.34	.6250-32 UN-2A		.700	17.78	.205	5.21
12	1.062	26.97	.986	25.04	.712	18.08	.7500-28 UN-2A	#12 .092/.096 (2.34/2.44)	.700	17.78	.205	5.21

SERIES 800 KEY POSITIONS

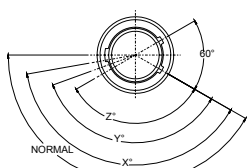

Plug

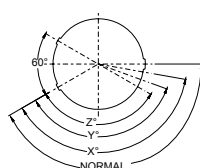

Receptacle

Key Position

Normal (N)
X
Y
Z

Key Rotation

150°
140°
130°
120°

Shell size 5 and 6: master key is located at top dead center for normal (N) position. Shell size 7 thru 12: master key is rotated 90° from TDC for normal position.

SERIES 800 PANEL CUTOUTS

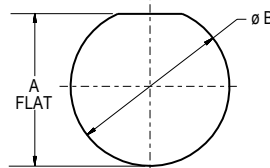

Shell Size	A Flat		Ø B	
	In.	mm.	In.	mm.
5	.295/.299	7.49/7.59	.317/.327	8.05/8.30
6	.358/.362	9.09/9.19	.380/.390	9.65/9.91
7	.424/.428	10.77/10.87	.442/.452	11.23/11.48
8	.479/.483	12.16/12.26	.505/.515	12.83/13.08
9	.537/.541	13.64/13.74	.567/.577	14.40/14.66
10	.610/.614	15.49/15.59	.630/.640	16.00/16.26
12	.717/.721	18.21/18.31	.755/.765	19.18/19.43

Dimensions in inches (millimeters) and are subject to change without notice.

Series 800 Mighty Mouse with UN Mating Thread Printed Circuit Board Receptacle Dimensions Square Flange Receptacle 800-012-02

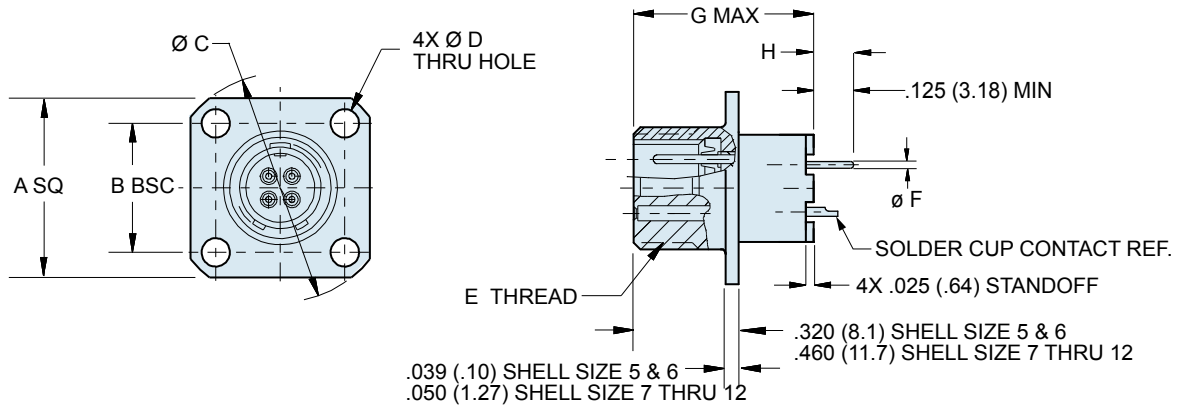

DIMENSIONS

Shell Size	A SQ		B		Ø C		Ø D		E Threads Mating	Ø F Tail Dia.	G Max		H			
	In.	mm.	In.	mm.	In.	mm.	± .005	± 0.13			In.	mm.	In.	mm.	In.	mm.
5	.527	13.39	.363	9.22	.680	17.27	.094	2.39	.3125-28 UN-2A	#23	.725	18.42	.426	10.82		
6	.588	14.92	.423	10.74	.750	19.05	.094	2.39	.3750-28 UN-2A		.018/.022 (0.46/0.56)	.725	18.42	.426	10.82	
7	.650	16.51	.483	12.27	.830	21.08	.128	3.25	.4375-28 UNEF-2A	#20	.700	17.78	.255	6.48		
8	.710	18.03	.542	13.77	.938	23.83	.128	3.25	.5000-32 UN-2A		.024/.028 (0.61/0.71)	.700	17.78	.255	6.48	
9	.938	23.83	.719	18.26	1.250	31.75	.128	3.25	.5625-32 UN-2A	#16	.700	17.78	.255	6.48		
10	.938	23.83	.719	18.26	1.250	31.75	.128	3.25	.6250-32 UN-2A		.060/.064 (1.52/1.63)	.700	17.78	.255	6.48	
12	1.031	26.19	.812	20.62	1.375	34.93	.128	3.25	.7500-28 UN-2A	#12	.700	17.78	.255	6.48		
											.092/.096 (2.34/2.44)	.700	17.78	.255	6.48	

SERIES 800 KEY POSITIONS

Key Position	Key Rotation		
Normal (N)	150°	<p>Plug Key Position</p>	<p>Receptacle Key Position</p>
X	140°		
Y	130°		
Z	120°		
<p>Shell size 5 and 6: master key is located at top dead center for normal (N) position. Shell size 7 thru 12: master key is rotated 90° from TDC.</p>			

Dimensions in inches (millimeters) and are subject to change without notice.