

Series 800 Mighty Mouse with UN Mating Thread Right Angle PCB Receptacle Headers

800-032-07



800-032 right angle I/O headers feature gold-plated size #23 contacts. UN mating thread, and aluminum or stainless steel shells. Rubber seal protects mated connectors from water ingress. 5 amp current rating, 500 VAC voltage rating. Contacts are factory-installed and are non-removable. Thermoplastic rear housing has #2-56 threaded inserts for attaching to circuit board with customer-supplied mounting screws. Connectors attach to chassis or panel with low-profile jam nut and O-ring. Available in six contact arrangements, these right angle headers are ideal for hostile environment 100/1000BASE-T Ethernet applications where commercial-grade RJ-45 jacks are not advised.

Right Angle PCB Receptacle

HOW TO ORDER SERIES 800 RIGHT ANGLE PCB RECEPTACLES

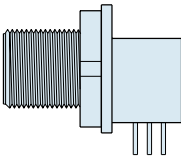
Sample Part Number					
800-032	-07	M	7-10	P	Z
Series	Shell Style	Shell Material / Finish	Shell Size- Insert Arrangement	Contact Type	Shell Key Position
800-032 PCB Receptacle	 -07 Jam Nut	C Aluminum / Black Anodize (Non-Conductive) RoHS Compliant M Aluminum / Electroless Nickel RoHS Compliant NF Aluminum / Cadmium with Olive Drab Chromate ZN Aluminum / Zinc-Nickel with Olive Drab Chromate ZNU Aluminum / Zinc-Nickel with Black Chromate MT Aluminum / Nickel-PTFE RoHS Compliant Z1 Stainless Steel / Passivated RoHS Compliant	5-3 3 #23 6-4 4 #23 6-7 7 #23 7-10 10 #23 8-13 13 #23 9-19 19 #23	P Pin S Socket	N Normal X Pos. X Y Pos. Y Z Pos. Z

Dimensions in inches (millimeters) and are subject to change without notice.

Series 800 Mighty Mouse with UN Mating Thread Right Angle PCB Receptacle Headers

800-032-07



Series 800

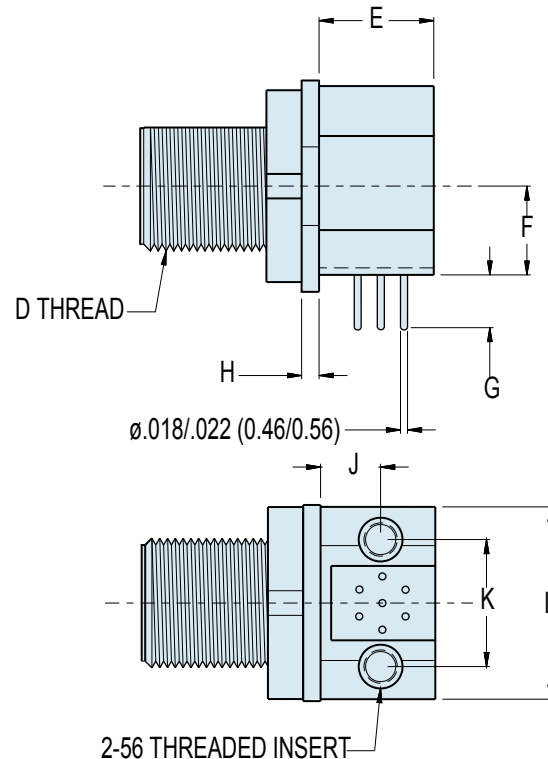
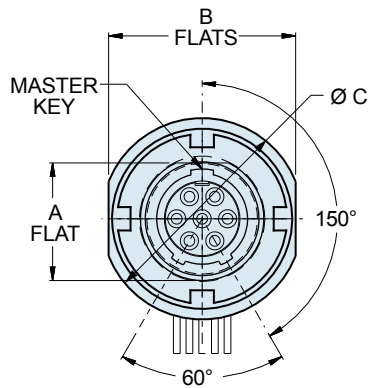

DIMENSIONS

Shell Size	A		B		Ø C		D Threads	E		F		G		H		J		K		L	
	In.	mm.	In.	mm.	In.	mm.		In.	mm.	In.	mm.	In.	mm.	In.	mm.	In.	mm.	In.	mm.	In.	mm.
5-3	.289	7.34	.498	12.65	.538	13.67	.3125-28 UN-2A	.260	6.60	.235	5.97	.257	6.53	.050	1.27	.165	4.19	.310	7.87	.486	12.34
6-4	.355	9.02	.560	14.22	.605	15.37	.3750-28 UN-2A	.330	8.38	.232	5.89	.285	7.24	.050	1.27	.224	5.69	.385	9.78	.580	14.73
6-7	.355	9.02	.560	14.22	.605	15.37	.3750-28 UN-2A	.350	8.89	.232	5.89	.285	7.24	.050	1.27	.187	4.75	.408	10.36	.580	14.73
7-10	.414	10.52	.640	16.26	.665	16.89	.4375-28 UNEF-2A	.350	8.89	.325	8.26	.285	7.24	.092	2.34	.170	4.32	.452	11.48	.640	16.26
8-13	.475	12.07	.730	18.54	.770	19.56	.5000-32 UN-2A	.490	12.45	.330	8.38	.285	7.24	.092	2.34	.230	5.84	.490	12.45	.680	17.27
9-19	.532	13.51	.805	20.45	.875	22.23	.5625-32 UN-2A	.490	12.45	.360	9.14	.275	6.99	.092	2.34	.342	8.69	.600	15.24	.800	20.32

PANEL CUTOUTS FOR RIGHT ANGLE PCB HEADERS

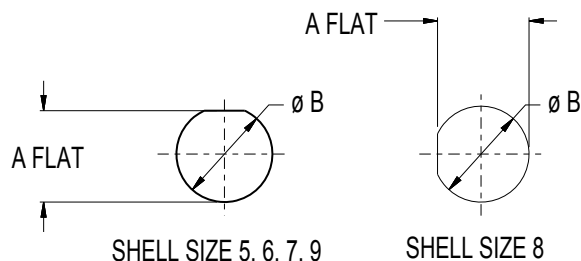

RECOMMENDED PANEL CUTOUT

Shell Size	A Flat		ØB	
	In.	mm.	In.	mm.
5	.294	7.47	.322	8.18
6	.360	9.14	.386	9.80
7	.419	10.64	.449	11.40
8	.481	12.22	.510	12.95
9	.538	13.67	.574	14.58

Dimensions in inches (millimeters) and are subject to change without notice.

FACE VIEWS OF RIGHT ANGLE PCB HEADERS

KEY POSITIONS	
Key Position	Key Rotation
Normal (N)	150°
X	140°
Y	130°
Z	120°

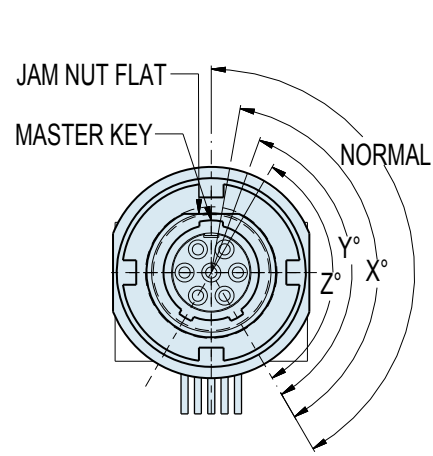

JAM NUT FLAT AND KEYWAY LOCATIONS
SHELL SIZE 5 AND 6
SOCKET FACE SHOWN

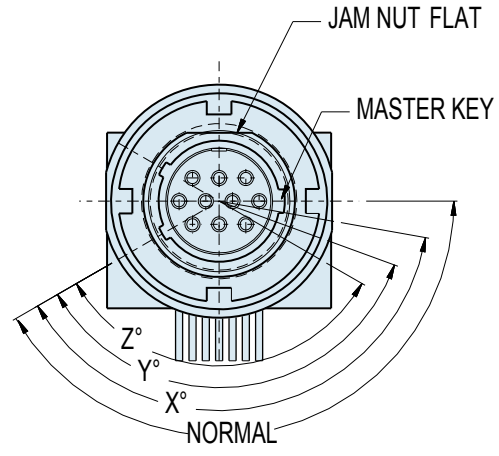

JAM NUT FLAT AND KEYWAY LOCATIONS
SHELL SIZE 7 10 POSITION
SOCKET FACE SHOWN

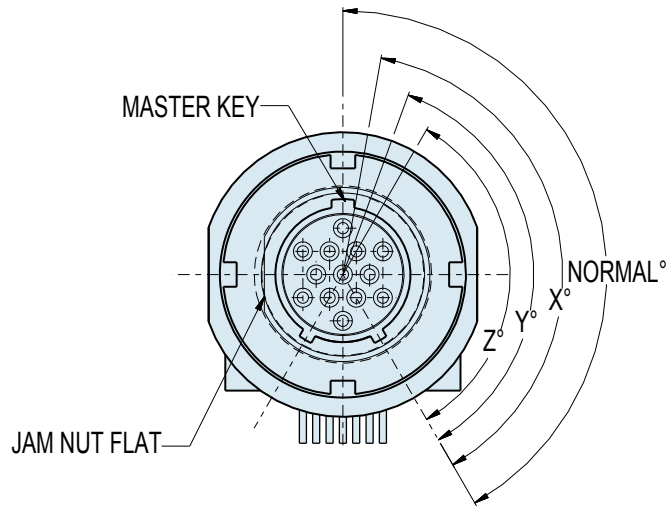

JAM NUT FLAT AND KEYWAY LOCATIONS
SHELL SIZE 8 13 POSITION
SOCKET FACE SHOWN

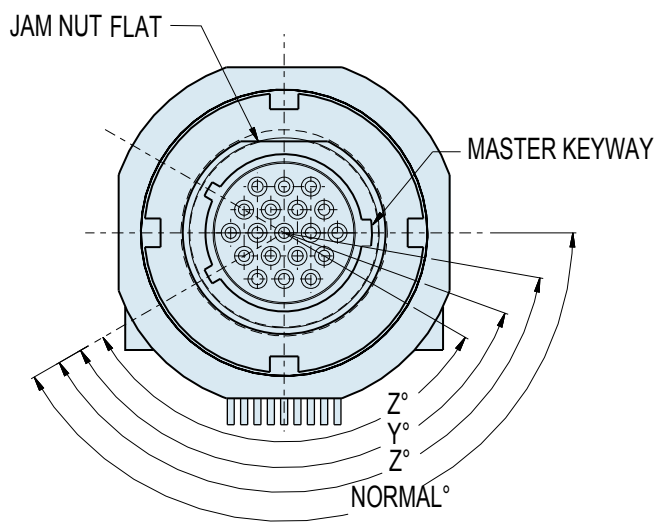

JAM NUT FLAT AND KEYWAY LOCATIONS
SHELL SIZE 9 19 POSITION
SOCKET FACE SHOWN

Dimensions in inches (millimeters) and are subject to change without notice.

Series 800 Mighty Mouse with UN Mating Thread Right Angle PCB Receptacle Headers 800-032 PCB Mounting Footprints



RIGHT ANGLE PCB FOOTPRINTS: PIN CONNECTORS

Patterns shown are for component mounting side of PCB.
Contacts are .022 (0.56) max. diameter, mounting holes are .093 (2.36) diameter

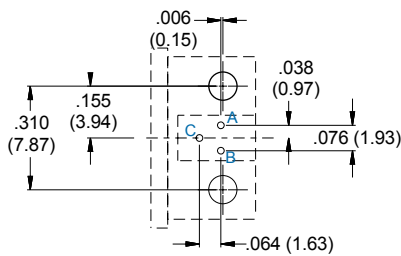

5-3P

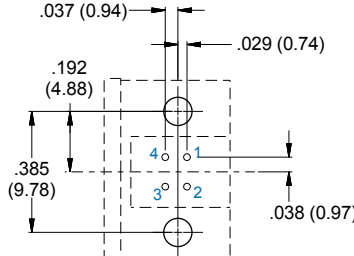

6-4P

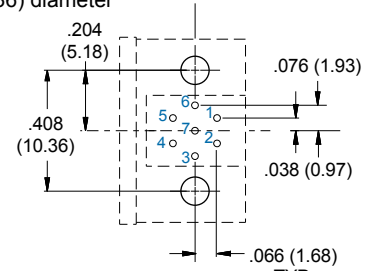

6-7P

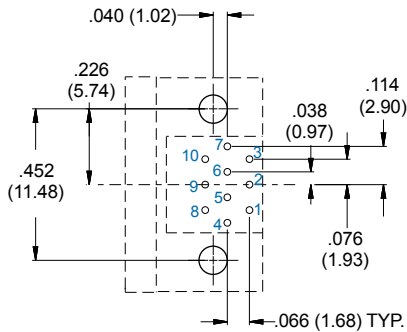

7-10P

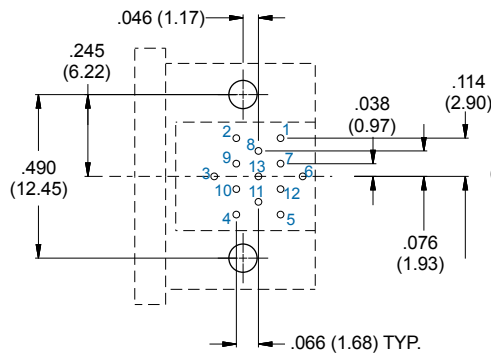

8-13P

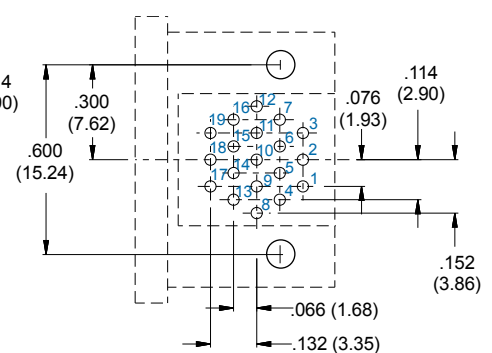

9-19P

RIGHT ANGLE PCB FOOTPRINTS: SOCKET CONNECTORS

Patterns shown are for component mounting side of PCB.

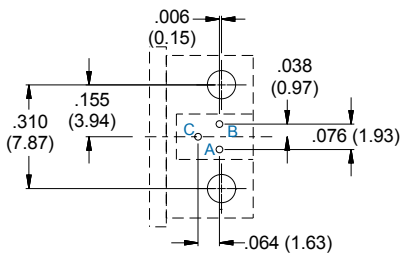

5-3S

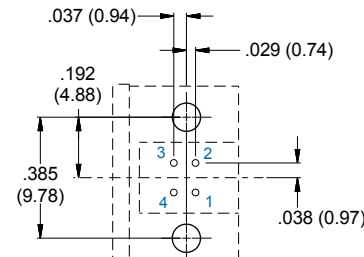

6-4S

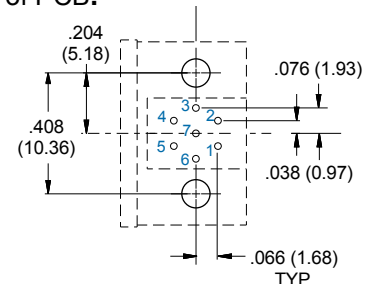

6-7S

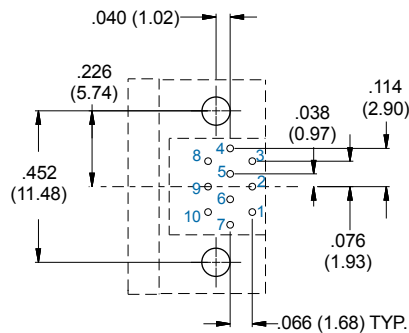

7-10S

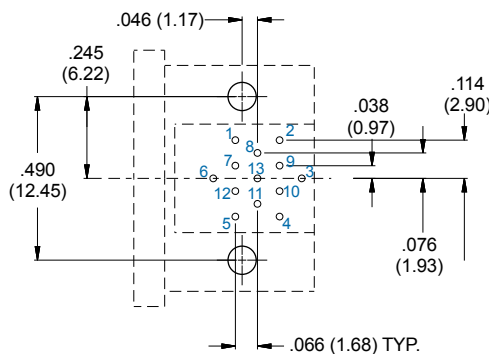

8-13S

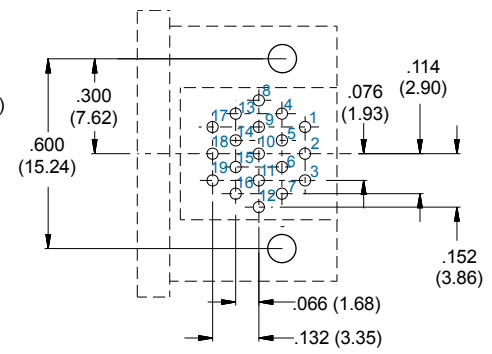

9-19S

Dimensions in inches (millimeters) and are subject to change without notice.