

Series 803 Mighty Mouse ¼ Turn Bayonet Coupling Connector Ordering Information

803-003 and 803-004 Crimp Receptacles



In-Line



Jam Nut



Flange Mount

Push-To-Mate, ¼ Turn to Lock.

These quick-mating connectors feature bayonet pins on the receptacle. Simply push the connectors together, then rotate the plug coupling nut 90° to lock the connectors together.

Three Shell Mounting Options:

Jam nut with O-ring for rear panel mounting, elliptical flange for front or rear panel mounting, or in-line receptacles for free-hanging cables.

Two Shell Styles:

Choose the integral band platform for direct attachment of a cable shield. Install a heat-shrink boot, or overmold directly onto the band platform. An accessory thread is available for attaching strain reliefs and backshells.

HOW TO ORDER

Sample Part Number

803-003



-07

NF

6-7

S

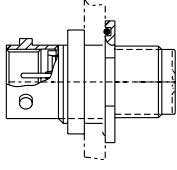
N

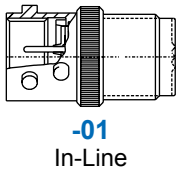
Series	Shell Style	Shell Material / Finish	Shell Size- Insert Arrangement	Contact Type	Shell Key Position	
803-003 Receptacle with Banding Platform for Direct Attachment of Cable Shield and Overmold	 -07 Jam Nut	C Aluminum / Black Anodize (Non-Conductive) RoHS Compliant	SEE CONTACT ARRANGEMENTS PAGE F-2	Connector supplied with contacts P Pin S Socket	N Normal Alternate Key Positions: X Y Z	
		M Aluminum / Electroless Nickel RoHS Compliant		Connector supplied without contacts A Pin Connector, less contacts B Socket Connector, less contacts		
		NF Aluminum / Cadmium with Olive Drab Chromate		Connectors with contacts are supplied with signal and/or power crimp contacts. These contacts are not installed. Coaxial contacts and non-standard signal contacts are ordered separately.		
803-004 Receptacle with Rear Accessory Thread	 -02 Flange Mount	ZN Aluminum / Zinc-Nickel with Olive Drab Chromate				
		ZNU Aluminum / Zinc-Nickel with Black Chromate				
		MT Aluminum / Nickel-PTFE RoHS Compliant				
	 -01 In-Line	Z1 Stainless Steel / Passivated RoHS Compliant				

Dimensions in inches (millimeters) and are subject to change without notice.

Series 803 Mighty Mouse ¼ Turn Bayonet Coupling Jam Nut Receptacle Dimensions

803-004-07 and 803-003-07

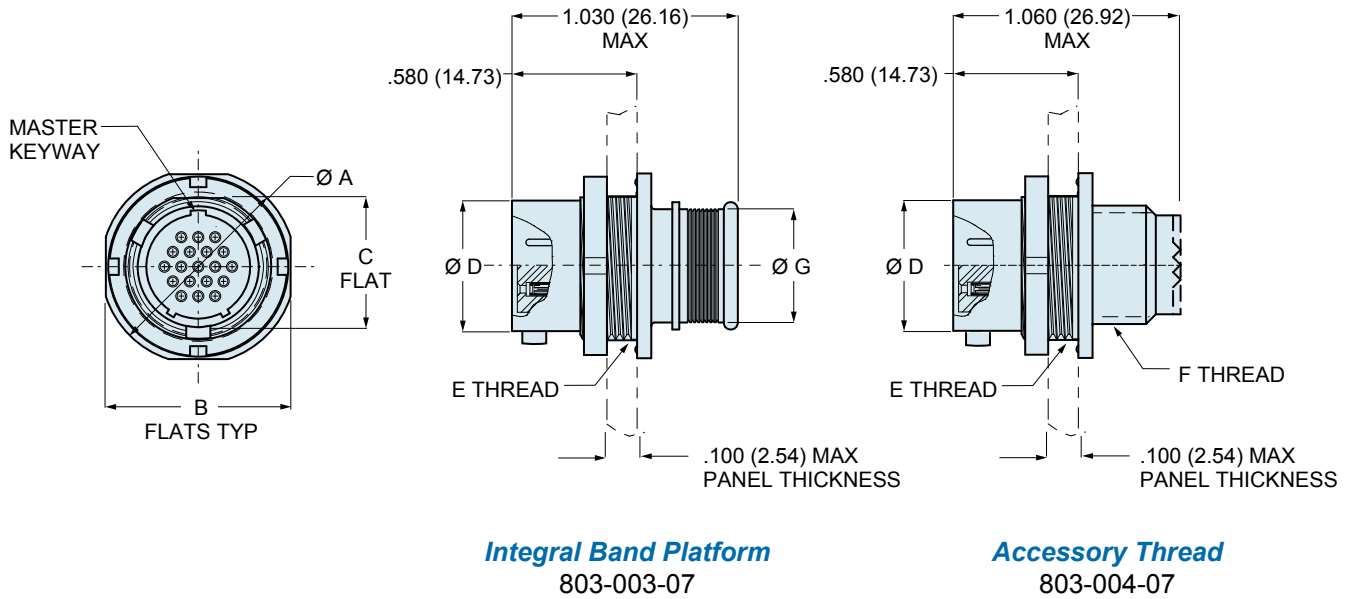

DIMENSIONS

Shell Size	Ø A		B Flats		C Flat		Ø D		E Thread	F Thread	Ø G	
	In.	mm.	In.	mm.	In.	mm.	In.	mm.			In.	mm.
5	.575	14.61	.545	13.84	.350	8.89	.300	7.62	.3750-32 UNEF-2A	.2500-32 UNEF-2A	.230	5.84
6	.635	16.13	.595	15.11	.410	10.41	.362	9.19	.4375-28 UNEF-2A	.3125-32 UNEF-2A	.286	7.26
7	.755	19.18	.723	18.36	.536	13.61	.436	11.07	.5625-32 UN-2A	.4375-28 UNEF-2A	.390	9.91
8	.755	19.18	.790	20.11	.593	15.10	.508	12.91	.6250-28 UN-2A	.5000-28 UNEF-2A	.440	11.18
9	.830	21.08	.790	20.07	.596	15.14	.561	14.25	.6250-28 UN-2A	.5625-24 UNEF-2A	.500	12.70
10	.890	22.61	.925	23.51	.721	18.31	.635	16.13	.7500-28 UN-2A	.6250-24 UNEF-2A	.562	14.27
12	1.078	27.38	1.044	26.52	.845	21.46	.714	18.14	.8750-28 UN-2A	.6875-24 UNEF-2A	.650	16.51
14	1.264	32.11	1.230	31.24	1.022	25.96	.865	21.97	1.0625-20 UN-2A	.9375-20 UNEF-2A	.805	20.45

ALTERNATE KEY POSITIONS

Pos.	A°	B°
N	150°	210°
X	75°	210°
Y	95°	230°
Z	140°	275°

JAM NUT PANEL CUTOUT

Shell Size	A Flat		Ø B	
	In. ± .002	mm. ± 0.05	In.	mm.
5	.355	9.02	.382	9.70
6	.415	10.54	.445	11.30
7	.541	13.74	.572	14.53
8	.603 .599	15.32 15.21	.635	16.13
9	.601	15.27	.643	16.33
10	.731 .727	18.57 18.47	.760	18.29
12	.850	21.59	.885	22.48
14	1.031	26.19	1.072	27.23

Dimensions in inches (millimeters) and are subject to change without notice.

Series 803 Mighty Mouse ¼ Turn Bayonet Coupling Flange Mount Receptacle Dimensions 803-004-02 and 803-003-02 Crimp Receptacles

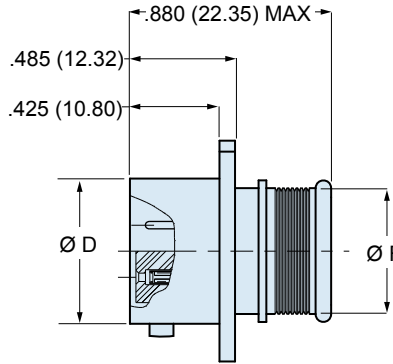
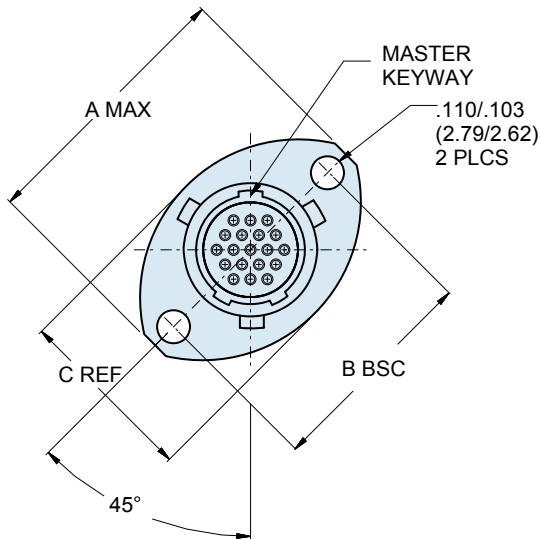

Integral Band Platform
803-003-02

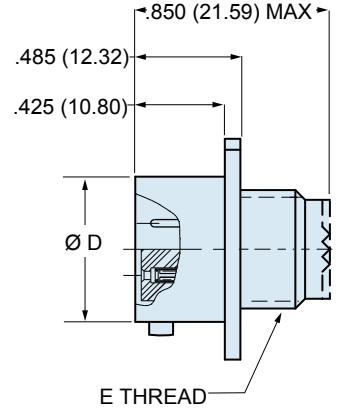

Accessory Thread
803-004-02

DIMENSIONS											
Shell Size	A Max.		B Bsc.		C Ref.		Ø D		E Thread	Ø F	
	In.	mm.	In.	mm.	In.	mm.	In.	mm.		In.	mm.
5	.703	17.86	.513	13.03	.460	11.68	.300	7.62	.2500-32 UNEF-2A	.230	5.84
6	.788	20.02	.598	15.19	.522	13.26	.362	9.19	.3125-32 UNEF-2A	.286	7.26
7	.890	22.61	.708	17.98	.590	14.99	.436	11.07	.4375-28 UNEF-2A	.390	9.91
8	1.154	29.31	.964	24.49	.668	16.97	.508	12.91	.5000-28 UNEF-2A	.440	11.18
9	1.207	30.66	1.017	25.83	.721	18.31	.561	14.25	.5625-24 UNEF-2A	.500	12.70
10	1.291	32.79	1.101	27.97	.795	20.19	.635	16.13	.6250-24 UNEF-2A	.562	14.27
12	1.394	35.41	1.204	30.58	.874	22.20	.714	18.14	.6875-24 UNEF-2A	.650	16.51
14	1.545	39.24	1.280	32.51	1.050	26.67	.865	21.97	.9375-20 UNEF-2A	.805	20.45

ALTERNATE KEY POSITIONS

Pos.	A°	B°
N	150°	210°
X	75°	210°
Y	95°	230°
Z	140°	275°

FLANGE MOUNT PANEL CUTOUTS

Shell Size	A		Ø B	
	In.	mm.	In.	mm.
5	.513	13.03	.365	9.25
6	.598	15.19	.430	10.92
7	.708	17.98	.520	13.21
8	.964	17.98	.592	15.04
9	1.017	25.83	.645	16.38
10	1.101	27.97	.726	18.44
12	1.204	30.58	.832	21.13
14	1.280	32.51	.945	24.00

Dimensions in inches (millimeters) and are subject to change without notice.

Series 803 Mighty Mouse ¼ Turn Bayonet Coupling

In-Line Receptacle Dimensions

803-004-01 and 803-003-01 Crimp Receptacles

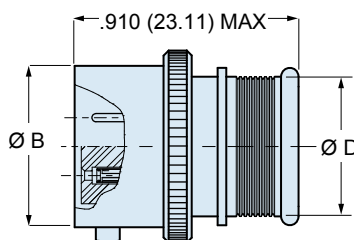
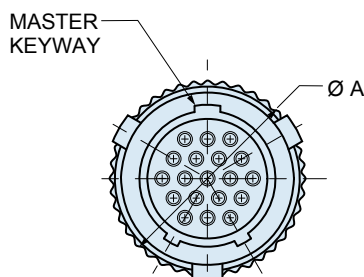

Integral Band Platform
803-003-01

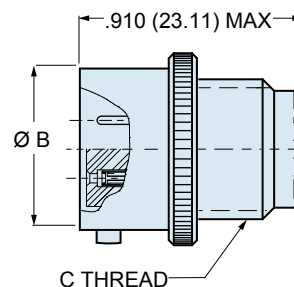

Accessory Thread
803-004-01

DIMENSIONS

Shell Size	A Max.		Ø B		C Thread	Ø D	
	In.	mm.	In.	mm.		In.	mm.
5	.402	10.21	.300	7.62	.2500-32 UNEF-2A	.230	5.84
6	.465	11.81	.362	9.19	.3125-32 UNEF-2A	.286	7.26
7	.500	12.70	.436	11.07	.4375-28 UNEF-2A	.390	9.91
8	.570	14.48	.508	12.90	.5000-28 UNEF-2A	.440	11.18
9	.652	16.56	.561	14.25	.5625-24 UNEF-2A	.500	12.70
10	.715	18.15	.635	16.13	.6250-24 UNEF-2A	.562	14.27
12	.805	20.45	.714	18.14	.6875-24 UNEF-2A	.650	16.51
14	.915	23.24	.865	21.97	.9375-20 UNEF-2A	.805	20.45

ALTERNATE KEY POSITIONS

Pos.	A°	B°
N	150°	210°
X	75°	210°
Y	95°	230°
Z	140°	275°

Dimensions in inches (millimeters) and are subject to change without notice.