

Series 805 Mighty Mouse Triple-Start PCB or Solder Cup Receptacle Ordering Information

805-005 and 805-017



**Series 805 Jam Nut
PCB Receptacle Connector**

Printed Circuit Board/Solder Cup Receptacles feature low profile shells for minimum protrusion inside enclosures and integral standoffs for board washout. Contacts are non-removable.

Water Immersion, Unmated

Specify **805-005** connectors for applications where open face water immersion is not a requirement. For MIL-STD-810 Method 512G immersion requirements, specify **805-017** watertight connectors. These 805-017 connectors are specially sealed ("MOD-518") and are 100% tested to maintain a helium leak rate of 1×10^{-4} cc/second at one atmosphere pressure differential from -40C to +70C.

HOW TO ORDER

Sample Part Number

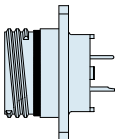
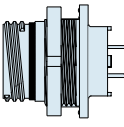
805-005	-07	M	10-13	P	B
Series	Shell Style	Shell Material / Finish	Shell Size- Insert Arrangement	Contact Type	Shell Key Position
<p>805-005 Receptacle for Solder Cup or PCB Termination, with Standard Epoxy Potting</p>	 <p style="text-align: center;">-02 Square Flange Front or Rear Mount</p>	<p style="text-align: center;">C Aluminum / Black Anodize (Non-Conductive) RoHS Compliant</p> <p style="text-align: center;">M Aluminum / Electroless Nickel RoHS Compliant</p> <p style="text-align: center;">MT Aluminum / Nickel-PTFE RoHS Compliant</p>	<p>SEE CONTACT ARRANGEMENTS PAGE H-2</p>	<p style="text-align: center;">P Pin, PC Tail</p> <p style="text-align: center;">S Socket, PC Tail</p>	<p style="text-align: center;">A Position A (Normal)</p> <p style="text-align: center;">B Position B</p> <p style="text-align: center;">C Position C</p> <p style="text-align: center;">D Position D</p>
<p>805-017 Receptacle for Solder Cup or PCB Termination, With Special "MOD-518" Sealing For Open Face (unmated) Water Immersion Requirements. 100% Leak Tested.</p>	<p style="text-align: center;">-12 Square Flange Rear Mount Non-Locking Clinch Nuts</p> <p style="text-align: center;">-22 Square Flange Rear Mount Locking Clinch Nuts</p>  <p style="text-align: center;">-07 Jam Nut Rear Mount</p>	<p style="text-align: center;">NF Aluminum / Cadmium with Olive Drab Chromate</p> <p style="text-align: center;">ZN Aluminum / Zinc-Nickel with Olive Drab Chromate</p> <p style="text-align: center;">ZNU Aluminum / Zinc-Nickel with Black Chromate</p> <p style="text-align: center;">Z1 Stainless Steel / Passivated RoHS Compliant</p> <p style="text-align: center;">ZB Stainless Steel / Olive Drab Chromate over Cadmium</p> <p style="text-align: center;">ZC Stainless Steel / Zinc Cobalt Alloy/Black Chromate</p>		<p style="text-align: center;">E Pin, Solder Cup</p> <p style="text-align: center;">F Socket, Solder Cup</p>	

Dimensions in inches (millimeters) and are subject to change without notice.

**Series 805 Mighty Mouse Triple-Start
PC Tail and Solder Cup Square Flange Receptacle**
805-005-02, 805-017-02



Series 805

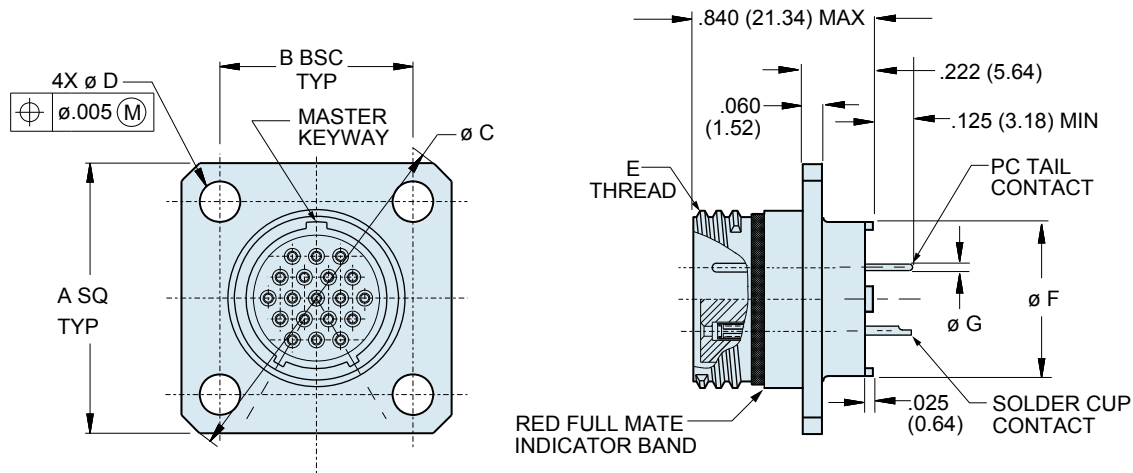

SQUARE FLANGE WITH PC TAIL
OR SOLDER CUP CONTACTS
805-005-02
805-017-02

DIMENSIONS

Shell Size	A		B		Ø C		Ø D		E Threads	Ø F		Ø G Tail Dia.
	In.	mm.	In.	mm.	In.	mm.	In. ± .003	mm. ± .08		In.	mm.	
8	.850	21.59	.660	16.76	1.150	29.21	.094	2.39	.5000-.1P-.3L-TS-2A	.330	8.38	#23
9	.913	23.19	.723	18.36	1.230	31.24	.094	2.39	.5625-.1P-.3L-TS-2A	.432	10.97	.018/.022 (0.46/0.56)
10	.975	24.77	.785	19.94	1.330	33.78	.094	2.39	.6250-.1P-.3L-TS-2A	.493	12.52	#20
11	1.039	26.39	.848	21.54	1.410	35.81	.094	2.39	.6875-.1P-.3L-TS-2A	.551	14.00	.024/.028 (0.61/0.71)
12	1.099	27.91	.909	23.09	1.500	38.10	.094	2.39	.7500-.1P-.3L-TS-2A	.620	15.78	#16
15	1.288	32.74	1.058	26.87	1.750	44.45	.128	3.25	.9375-.1P-.3L-TS-2A	.703	17.86	.060/.064 (1.52/1.63)
18	1.475	37.47	1.255	31.88	2.000	50.80	.128	3.25	1.1250-.1P-.3L-TS-2A	.863	21.92	#12
19	1.537	71.06	1.327	33.71	2.094	53.19	.128	3.25	1.1875-.1P-.3L-TS-2A	.912	23.16	.092/.096 (2.34/2.44)
23	1.787	45.39	1.570	39.88	2.440	61.98	.128	3.25	1.4375-.1P-.3L-TS-2A	1.162	29.51	

PERFORMANCE SPECIFICATIONS

DWV	#23 500 VAC Sea level, #20HD 750 VAC, #12 AND #16 1800 VAC
Insulation Resistance	5000 Megohms Minimum
Operating Temperature	-55° C. to +150° C.
Immersion, Mated	MIL-STD-810 Method 512. One Meter for One Hour.
EMI	65 dB Minimum from 1 GHz. to 10 GHz.

MATERIALS AND FINISHES

Connector Shell	Aluminum or Stainless Steel
Insulator	Liquid Crystal Polymer (LCP)
Seals	Fluorosilicone Rubber, Blue
Contact	Copper Alloy, Gold over Nickel Plating
Contact Retainer Clip	Beryllium Copper, Unplated

SERIES 805 KEY POSITIONS

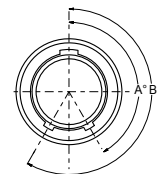

Key Position	Key Rotation	
	A	B
Normal (A)	150°	210°
B	75°	210°
C	95°	230°
D	140°	275°

Dimensions in inches (millimeters) and are subject to change without notice.

© 2010 Glenair, Inc.

CAGE Code 06324

Printed in U.S.A.

GLENAIR, INC. • 1211 AIR WAY • GLENDALE, CA 91201-2497 • 818-247-6000 • FAX 818-500-9912

www.glenair.com

H-13

E-Mail: sales@glenair.com



**Series 805 Mighty Mouse Triple-Start
PC Tail and Solder Cup Jam Nut Receptacle**
805-005-07, 805-017-07

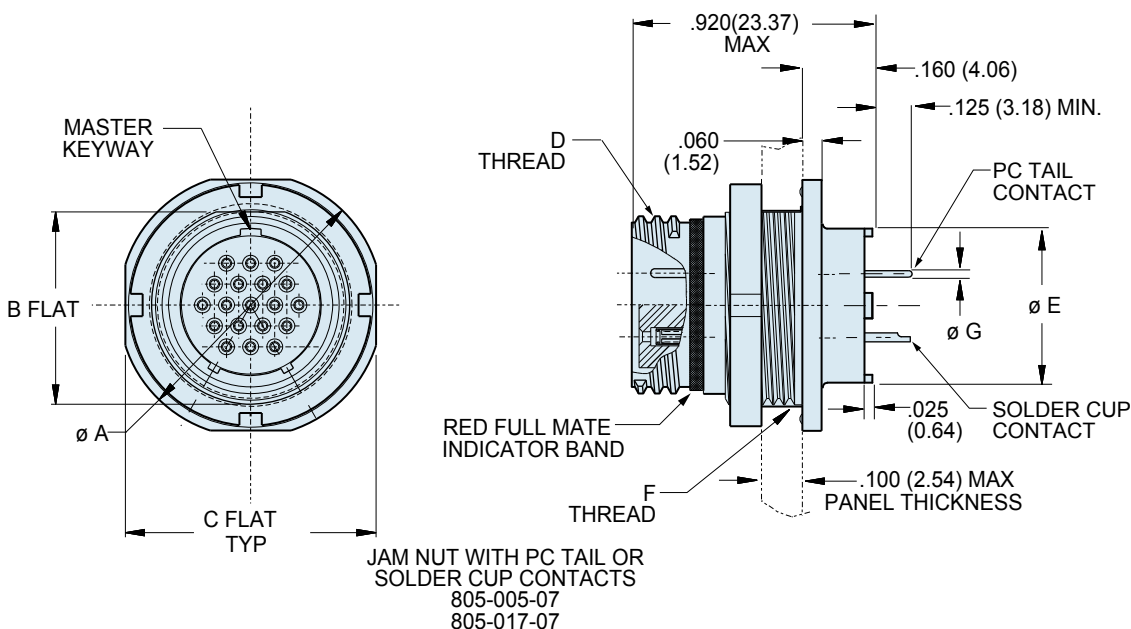

DIMENSIONS

Shell Size	Ø A		B		C		D Threads	Ø E		F Threads	Ø G Tail Dia.
	In.	mm.	In.	mm.	In.	mm.		In.	mm.		
8	.760	19.30	.535	13.59	.730	18.54	.5000-1P-3L-TS-2A	.330	8.38	.5625-28 UNEF-2A	#23
9	.880	22.35	.661	16.79	.850	21.59	.5625-1P-3L-TS-2A	.432	10.97	.6875-28 UN-2A	.018/.022 (0.46/0.56)
10	.880	22.35	.661	16.79	.850	21.59	.6250-1P-3L-TS-2A	.493	12.52	.6875-28 UN-2A	#20
11	.955	24.26	.721	18.31	.925	23.50	.6875-1P-3L-TS-2A	.551	14.00	.7500-28 UN-2A	.024/.028 (0.61/0.71)
12	1.060	26.92	.784	19.91	1.035	26.29	.7500-1P-3L-TS-2A	.620	15.78	.8125-28 UN-2A	#16
15	1.203	30.56	.970	24.64	1.173	29.79	.9375-1P-3L-TS-2A	.703	17.86	1.0000-28 UN-2A	.060/.064 (1.52/1.63)
18	1.389	35.28	1.147	29.13	1.359	34.52	1.1250-1P-3L-TS-2A	.863	21.92	1.1875-28 UN-2A	#12
19	1.450	36.83	1.221	31.01	1.420	36.07	1.1875-1P-3L-TS-2A	.912	23.16	1.2500-28 UN-2A	
23	1.705	43.31	1.470	37.34	1.675	42.55	1.4375-1P-3L-TS-2A	1.162	29.51	1.500-25 UN-2A	.092/.096 (2.34/2.44)

PANEL CUTOUT FOR JAM NUT RECEPTACLE

Shell Size	A Flat		Ø B	
	In. ± .002	mm. ± 0.05	In. ± .005	mm. ± 0.13
8	.543	13.79	.572	14.53
9	.669	16.99	.698	17.73
10	.669	16.99	.698	17.73
11	.729	18.51	.760	19.30
12	.792	20.17	.822	20.88
15	.978	24.84	1.010	25.65
18	1.155	29.34	1.198	30.43
19	1.229	31.22	1.260	32.00
23	1.480	37.59	1.510	38.35

SERIES 805 KEY POSITIONS

Key Position	Key Rotation	
	A	B
Normal (A)	150°	210°
B	75°	210°
C	95°	230°
D	140°	275°

Dimensions in inches (millimeters) and are subject to change without notice.