



# AS85049/62 and MS38999/2 Series 310 Straight Shrink Boot Adapter

## CONNECTOR DESIGNATOR:

F

MIL-DTL-38999 Series I & II,  
40M38277, PAN 6433-1,  
PATT 614, PATT 616,  
NFC93422 Series HE308 & HE309

Basic  
Part Number

Shell  
Size

Drain Hole Option  
(Omit for None)

M85049/62

-

10

W

D

Order Boot Separately

## Finish

*A* = Black Anodize  
*N* = Electroless Nickel  
*W* = 500 Hr. Cadmium Olive Drab over  
Electroless Nickel

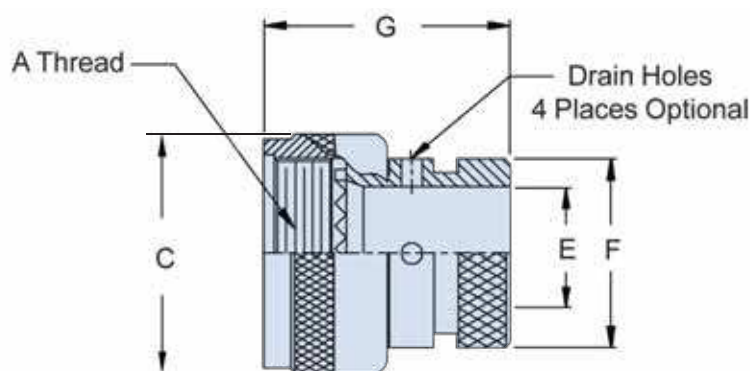

### TABLE I: Shell Size and Dimensions

Shell Size	A Thread Class 2B	C Max	E Dia Min	F Dia Min	G Max
08	.438 - 28 UNEF	.750 (19.1)	.250 (6.4)	.533 (13.5)	1.000 (25.4)
10	.562 - 24 UNEF	.850 (21.6)	.375 (9.5)	.605 (15.4)	1.000 (25.4)
12	.688 - 24 UNEF	1.000 (25.4)	.500 (12.7)	.774 (19.7)	1.000 (25.4)
14	.813 - 20 UNEF	1.100 (27.9)	.625 (15.9)	.838 (21.3)	1.000 (25.4)
16	.938 - 20 UNEF	1.250 (31.8)	.750 (19.1)	.963 (24.5)	1.000 (25.4)
18	1.063 - 18 UNEF	1.400 (35.6)	.812 (20.6)	1.042 (26.5)	1.000 (25.4)
20	1.188 - 18 UNEF	1.500 (38.1)	.937 (23.8)	1.217 (30.9)	1.000 (25.4)
22	1.313 - 18 UNEF	1.650 (41.9)	1.062 (27.0)	1.355 (34.4)	1.000 (25.4)
24	1.438 - 18 UNEF	1.750 (44.5)	1.188 (30.2)	1.443 (36.7)	1.000 (25.4)

## APPLICATION NOTES

- For complete dimensions see the applicable Military Specification.

Dimensions in inches (millimeters) and are subject to change without notice.

CAGE Code 06324

Printed in U.S.A.

© 2011 Glenair, Inc.

GLENAIR, INC. • 1211 AIR WAY • GLENDALE, CA 91201-2497 • 818-247-6000 • FAX 818-500-9912

www.glenair.com

H-22

E-Mail: sales@glenair.com