

**CONNECTOR  
DESIGNATOR**

**G**

**ROTATABLE  
COUPLING**

**TYPE A OVERALL  
SHIELD TERMINATION**

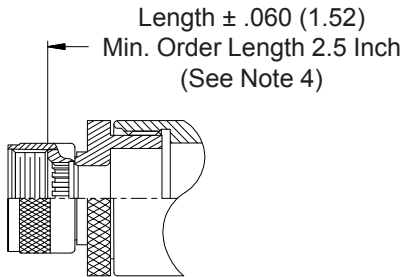
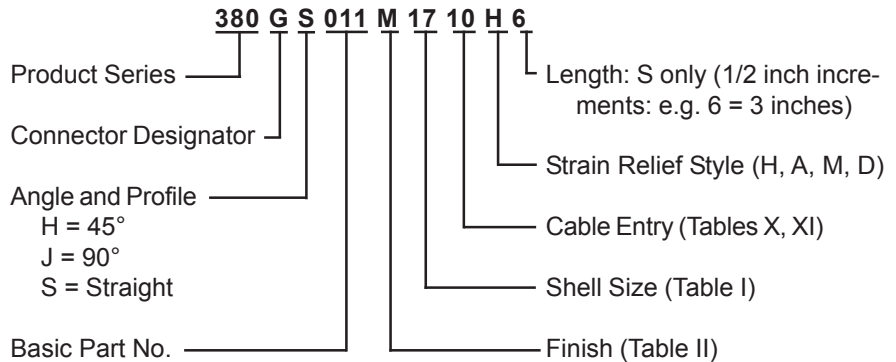

**STYLE 2  
(STRAIGHT  
See Note 1)**

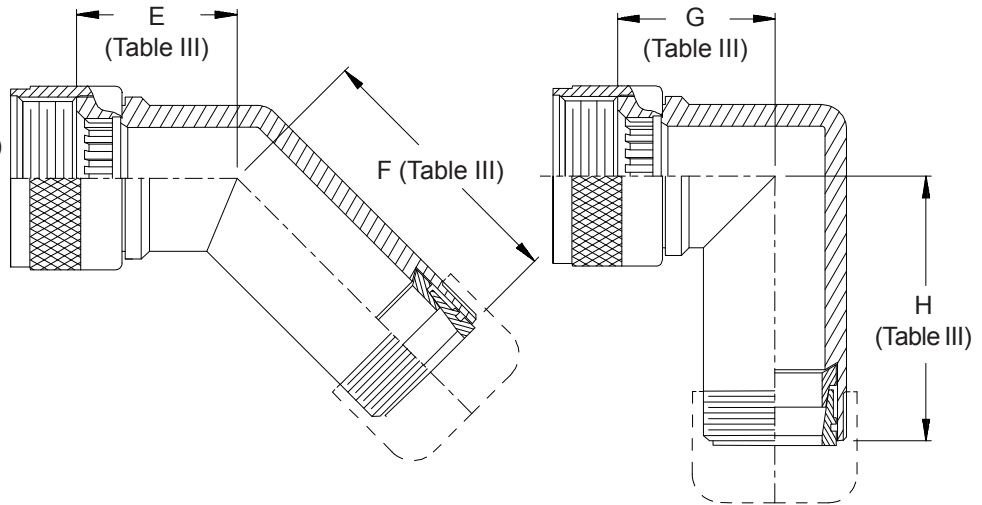
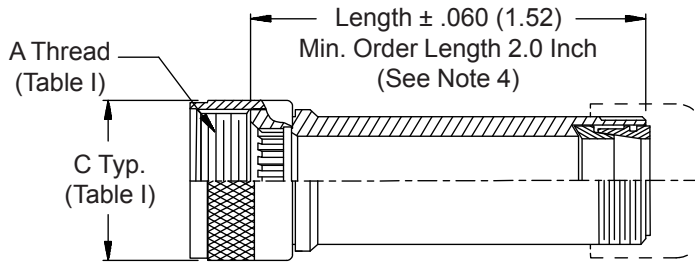

**STYLE 2  
(45° & 90°  
See Note 1)**

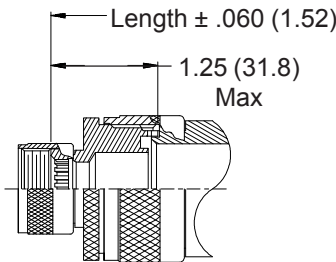

**STYLE H  
Heavy Duty  
(Table X)**

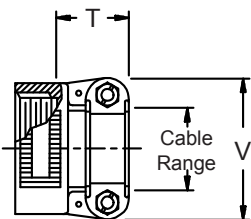

**STYLE A  
Medium Duty  
(Table XI)**

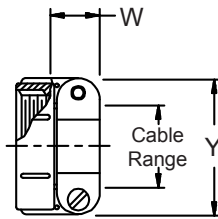

**STYLE M  
Medium Duty  
(Table XI)**

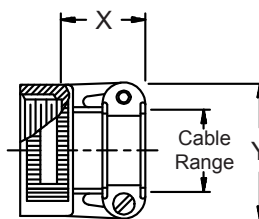

**STYLE D  
Medium Duty  
(Table XI)**

