



**M29504/05
181-001**
Size 16 MIL-DTL-38999 Series III Type Fiber Optic Socket Terminus



B

Ultra low dB loss QPL'd socket terminus for MIL-DTL-38999 Series III



Part Number	Fiber Size Core/Cladding/Coating (Microns)	Ø A (Microns)	Ref. M29504/05-XXXX
181-001-125	9/125 (Singlemode)	125.5	M29504/05-4237
181-001-126S	9/125 (Singlemode)	126.0	M29504/05-4238
181-001-126	50/125 & 62.5/125	126.0	M29504/05-4239
181-001-127	50/125 & 62.5/125	127.0	M29504/05-4046
181-001-142	100/140	142.0	M29504/05-4049
181-001-144	100/140	144.0	N/A
181-001-145	100/140	145.0	M29504/05-4050
181-001-156	62.5/125/155 (Polyimide)	156.0	M29504/05-4240
181-001-157	62.5/125/155 (Polyimide)	157.0	M29504/05-4241
181-001-173	100/140/172 (Polyimide)	173.0	M29504/05-4088
181-001-175	100/140/172 (Polyimide)	175.0	M29504/05-4242
181-001-231	200/230	231.0	N/A
181-001-236	200/233	236.0	M29504/05-4243
181-001-286	200/280	286.0	M29504/05-4244
181-001-448	400/440	448.0	M29504/05-4245
181-001-533	486/500	533.0	N/A

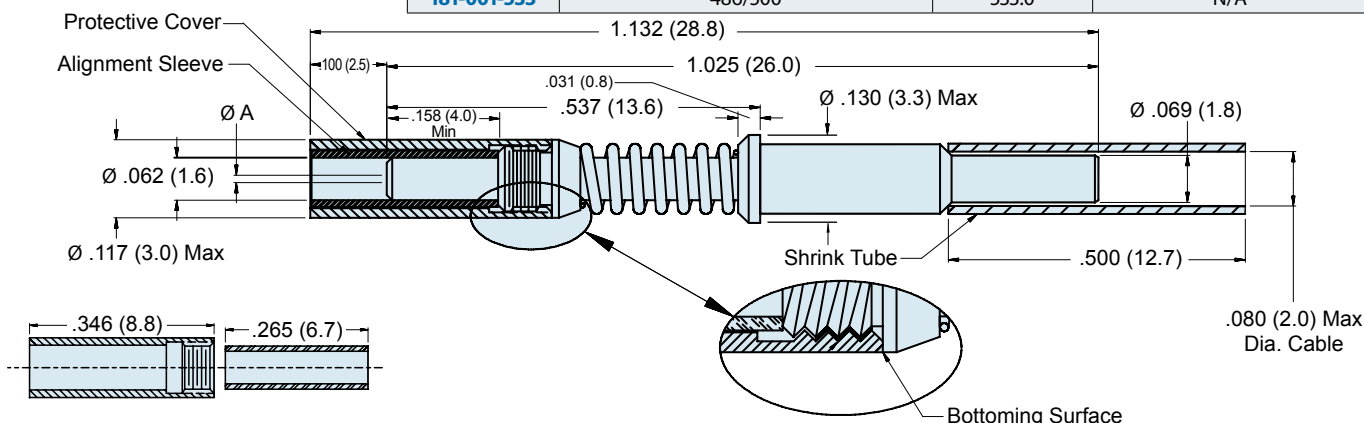

Ceramic alignment sleeve supplied with terminus. Add **K** to the end of part number development to supply with optional stainless steel alignment sleeve e.g. 181-001-126K.

Part Number	Description
181-001-S	Ceramic Alignment Sleeve
181-001-K	Stainless Steel Alignment Sleeve
181-001-C	Protective cover

Material and Finish

Ferrule: Zirconia Ceramic
Alignment Sleeve: Zirconia Ceramic or Stainless Steel/Passivate.
Terminus Assembly: Stainless Steel/Passivate
Spacer, Spring, and Cover: Stainless Steel/Passivate • Shrink Tube: Kynar

Notes

Alignment Sleeve & Protective Cover can also be ordered separately (Table II).
See assembly procedure GAP-015 for complete termination instructions.
Recommended Insertion/Extraction tool: P/N M81969/14-03 or equivalent