

233-105-05

MIL-DTL-38999 Series III Type

In-Line Environmental Receptacle Connector

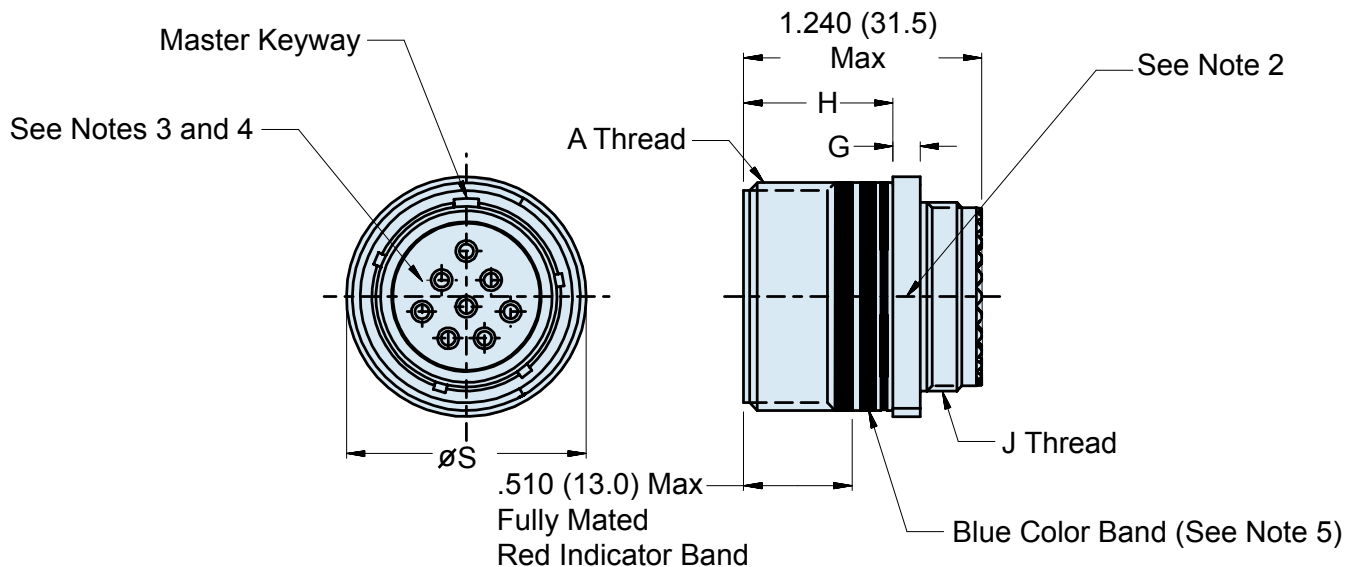
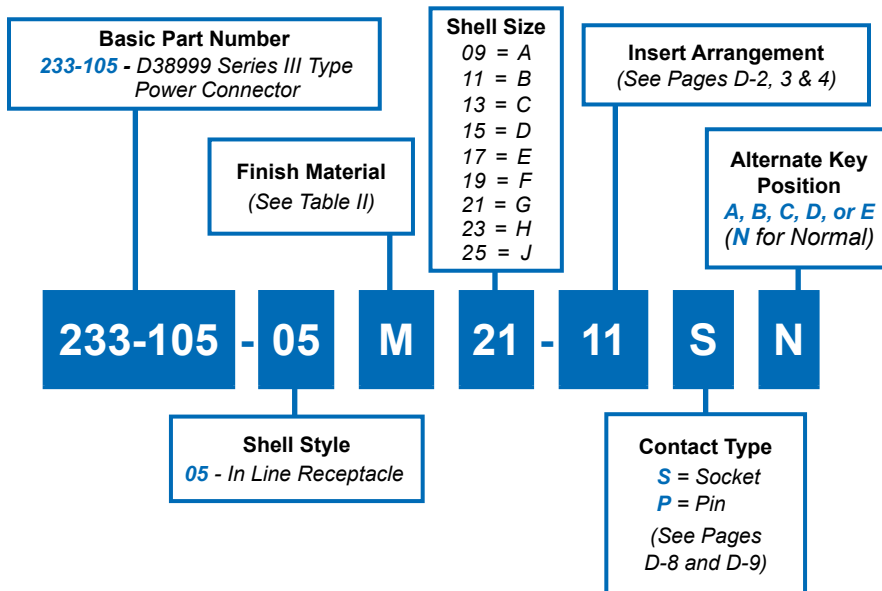

Consult factory for available insert arrangements.

APPLICATION NOTES

- Material/ Finishes:
Shells - See Table II
Insulator- High Grade Rigid Dielectric/ N.A
Seals- Fluorosilicone/ N.A.
- Assembly to be identified with Glenair's name, part number and date code space permitting.
- Insert arrangement in accordance with MIL-STD-1560.
- Insert arrangement shown is for reference only.
- Blue Color Band indicates rear release retention system.
- Metric Dimensions (mm) are indicated in parentheses.

233-105-05
MIL-DTL-38999 Series III Type
In-Line Environmental Receptacle Connector



TABLE II: FINISH			
SYM	MATERIAL	FINISH	MIL SYM
M	Aluminum	Electroless Nickel	F
NF		Cadmium O.D. Over Electroless Nickel	W
ZN		Zinc Ni, Olive Drab	Z
ZE		Zinc Ni, No Chromate	
ZR		Zinc Ni, Black (Tri-Valent CR)	
AL		Pure-Dense Electro-Deposited Aluminum	P
MT		Ni-PTFE 1000 Hour Grey™	T
XM		Composite	Electroless Nickel
XMT	Ni-PTFE 1000 Hour Grey™		
XO	No Finish		
XW	Cadmium O.D. over Electroless Nickel		J
Z1	Stainless Steel	Passivate	
ZC		Zinc Colbalt	
ZL		Electro-Deposited Nickel	
ZW		Cadmium O.D. over Nickel	
AB	Marine Bronze	None (Clean Only)	

*Consult Factory for Additional Plating Options

TABLE III: SHELL SIZE						
Shell Size Code	Shell Size	A Thread	G	H	S Max Dia	J Thread
A	09	.6250-.1P-.3L-TS-2A	.144 (3.7) .083 (2.1)	.823 (20.9) .768 (19.5)	.858 (21.8)	M12 x 1.0-6g 0.100R
B	11	.7500-.1P-.3L-TS-2A	.144 (3.7) .083 (2.1)	.823 (20.9) .768 (19.5)	.984 (25.0)	M15 x 1.0-6g 0.100R
C	13	.8750-.1P-.3L-TS-2A	.144 (3.7) .083 (2.1)	.823 (20.9) .768 (19.5)	1.157 (29.4)	M18 x 1.0-6g 0.100R
D	15	1.0000-.1P-.3L-TS-2A	.144 (3.7) .083 (2.1)	.823 (20.9) .768 (19.5)	1.280 (32.5)	M22 x 1.0-6g 0.100R
E	17	1.1875-.1P-.3L-TS-2A	.144 (3.7) .083 (2.1)	.823 (20.9) .768 (19.5)	1.406 (35.7)	M25 x 1.0-6g 0.100R
F	19	1.2500-.1P-.3L-TS-2A	.144 (3.7) .083 (2.1)	.823 (20.9) .768 (19.5)	1.516 (38.5)	M28 x 1.0-6g 0.100R
G	21	1.3750-.1P-.3L-TS-2A	.171 (65.2) .083 (39.8)	.791 (20.0) .736 (18.7)	1.642 (41.7)	M31 x 1.0-6g 0.100R
H	23	1.5000-.1P-.3L-TS-2A	.171 (65.2) .083 (39.8)	.791 (20.0) .736 (18.7)	1.768 (44.9)	M34 x 1.0-6g 0.100R
J	25	1.6250-.1P-.3L-TS-2A	.171 (65.2) .083 (39.8)	.791 (20.0) .736 (18.7)	1.890 (48.0)	M37 x 1.0-6g 0.100R

