



Series 811 Mighty Mouse High Density (HD) Jam Nut PCB Receptacle Connectors 811-005-07 and 811-006-07 With Straight PC Tails



Jam Nut PC Tail Receptacles

Series 811 Mighty Mouse High Density jam nut PCB receptacles have straight PC tails for termination to flex circuits or rigid boards. These receptacles are backpotted with epoxy. The TwistPin contact system meets requirements of MIL-DTL-83513 and provides outstanding resistance to high levels of shock and vibration. Choose solder-dipped or gold-plated tails. Select 811-006-07 with enhanced waterblocking for open face (unmated) immersion requirements. Molded plastic endcap has standoffs. 3A current rating, 600 VAC dielectric withstanding voltage.

HOW TO ORDER SERIES 811-005-07 AND 811-006-07 JAM NUT PC TAIL RECEPTACLES

Sample Part Number						
811-005-07	MT	5-7	P	A	3	-.125
Series	Shell Material and Finish	Shell Size - Insert Arr.	Contact Type	Key Position	PC Tail Finish	PC Tail Length
811-005-07 Series 811 Rear Panel Mount Jam Nut Receptacle, Straight PC Tails, Standard Epoxy Sealing	ME Electroless Nickel	5-7 7 Contacts	P Pin Contacts	A Normal	3 Solder-Dipped in 63/37 Tin-Lead	.090 .125 .250
811-006-07 Series 811 Rear Panel Mount Jam Nut Receptacle, Straight PC Tails, Enhanced Waterblocking for Open Face (Unmated) Water Immersion	MT Nickel-PTFE ZR Black Zinc-Nickel	6-12 12 Contacts 7-22 22 Contacts 8-30 30 Contacts 9-42 42 Contacts	S Socket Contacts	Alternate Key Positions B C D E F	4 Gold Plated	(Other lengths are readily available)

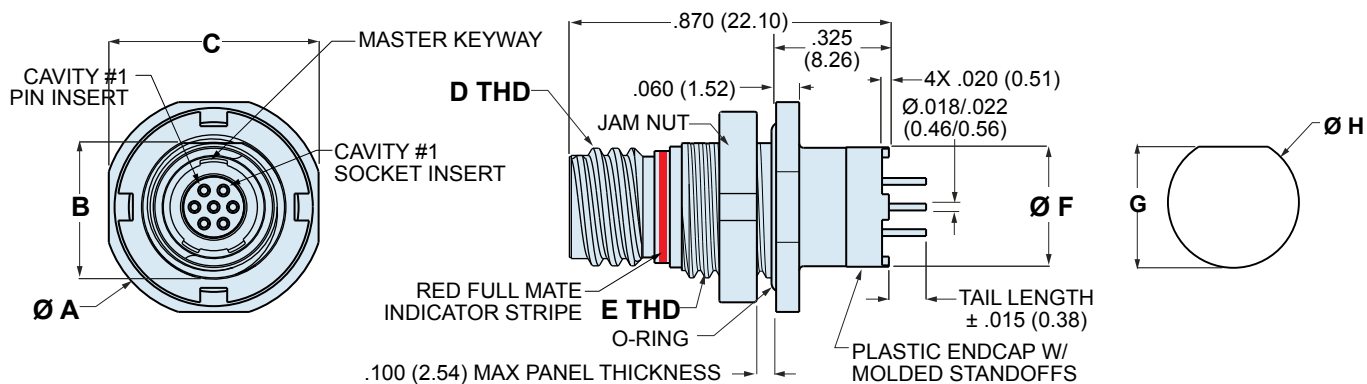

DIMENSIONS										PANEL CUTOUT					
Shell Size	Ø A		B		C		D Thread	E THD UN-2A	Ø F		Shell Size	G		H Ø	
	In.	mm.	In.	mm.	In.	mm.			In.	mm.		In.±.002	mm.±0.05	In.±.002	mm.±0.05
5	.575	14.61	.350	8.89	.545	13.84	.3125-.05P-.1L-2A	.375-28	.350	8.89	5	.356	9.04	.385	9.78
6	.635	16.13	.410	10.41	.602	15.29	.3750-.05P-.1L-2A	.4375-28	.490	12.45	6	.416	10.57	.447	11.35
7	.755	19.18	.536	13.61	.723	18.36	.4375-.05P-.1L-2A	.5625-32	.600	15.24	7	.542	13.77	.572	14.53
8	.755	19.18	.536	13.61	.723	18.36	.5000-.05P-.1L-2A	.5625-32	.670	17.02	8	.542	13.77	.572	14.53
9	.830	21.08	.596	15.14	.791	20.09	.5625-.05P-.1L-2A	.625-28	.770	19.56	9	.602	15.29	.635	16.13

Dimensions in Inches (millimeters) are subject to change without notice.