

TG69 and TG82
Soft Jaw Pliers and Strap Wrench Assembly Tool
 for Use with MIL-DTL-28840 Connectors



TG69

P

Basic
 Number

Finish
P - Nickel Plate
 (Omit for Standard
 Cad/Bright Dip)

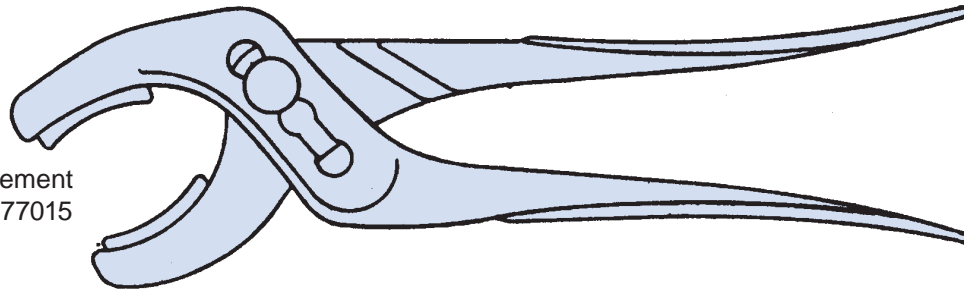

Nylon Replacement
 Inserts P/N G77015

Basic
 Number

TG82

7.0 (177.8) Approx.

7/16 (11.1)

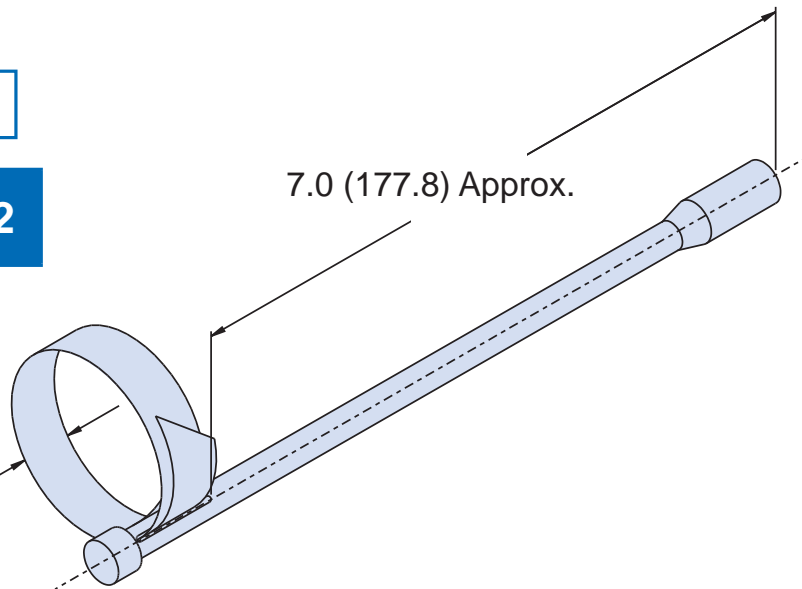

F

Notes

2.50 (63.5) Max Capacity; Not recommended for composite coupling nuts (use 600-091 or 600-157)
 1/4 Inch Drive
 The replacement strap part number is G62748-11. Consult Factory for other lengths.

Dimensions in Inches (millimeters) are subject to change without notice.