



Features

- Formerly J. W. Miller® model
- Current rating up to 6.33 A
- Inductance range: 10 μ H to 18,000 μ H
- RoHS compliant*

Applications

- DC/DC converters
- Power supplies
- Desktop notebooks
- Output chokes

6100 Series - Radial Lead RF Choke

Electrical Specifications (@ 25 °C)

Part Number	Inductance (μ H) ± 10 %	Q (Ref.)	Test Frequency		SRF (MHz) Typ.	DCR (Ω) max.	I dc (A)
			L	Q			
6100-100K-RC	10	21.0	100 KHz	2.52 MHz	21.0	0.020	6.33
6100-120K-RC	12	18.3	100 KHz	2.52 MHz	18.3	0.022	5.75
6100-150K-RC	15	15.5	100 KHz	2.52 MHz	15.5	0.024	5.28
6100-180K-RC	18	13.8	100 KHz	2.52 MHz	13.8	0.027	4.80
6100-220K-RC	22	12.0	100 KHz	2.52 MHz	12.0	0.039	4.52
6100-270K-RC	27	11.3	100 KHz	2.52 MHz	11.3	0.047	3.75
6100-330K-RC	33	10.5	100 KHz	2.52 MHz	10.5	0.059	3.39
6100-390K-RC	39	9.4	100 KHz	2.52 MHz	9.4	0.079	3.08
6100-470K-RC	47	8.3	100 KHz	2.52 MHz	8.3	0.084	2.79
6100-560K-RC	56	7.6	100 KHz	2.52 MHz	7.6	0.089	2.57
6100-680K-RC	68	6.8	100 KHz	2.52 MHz	6.8	0.11	2.38
6100-820K-RC	82	6.3	100 KHz	2.52 MHz	6.3	0.15	2.18
6100-101K-RC	100	5.8	100 KHz	796 KHz	5.8	0.16	1.98
6100-121K-RC	120	5.0	100 KHz	796 KHz	5.0	0.23	1.80
6100-151K-RC	150	4.2	100 KHz	796 KHz	4.2	0.24	1.61
6100-181K-RC	180	3.9	100 KHz	796 KHz	3.9	0.31	1.45
6100-221K-RC	220	3.5	100 KHz	796 KHz	3.5	0.35	1.32
6100-271K-RC	270	3.2	100 KHz	796 KHz	3.2	0.52	1.18
6100-331K-RC	330	2.9	100 KHz	796 KHz	2.9	0.60	1.10
6100-391K-RC	390	2.8	100 KHz	796 KHz	2.8	0.64	1.00
6100-471K-RC	470	2.6	100 KHz	796 KHz	2.6	0.77	0.90
6100-561K-RC	560	2.3	100 KHz	796 KHz	2.3	0.87	0.83
6100-681K-RC	680	2.0	100 KHz	796 KHz	2.0	1.09	0.76
6100-821K-RC	820	1.8	100 KHz	796 KHz	1.8	1.44	0.69
6100-102K-RC	1000	1.6	100 KHz	252 KHz	1.6	1.55	0.62
6100-122K-RC	1200	1.4	100 KHz	252 KHz	1.4	2.20	0.57
6100-152K-RC	1500	1.3	100 KHz	252 KHz	1.3	2.50	0.51
6100-182K-RC	1800	1.2	100 KHz	252 KHz	1.2	3.65	0.47
6100-222K-RC	2200	1.1	100 KHz	252 KHz	1.1	4.26	0.42
6100-272K-RC	2700	1.0	100 KHz	252 KHz	1.0	5.41	0.38
6100-332K-RC	3300	1.0	100 KHz	252 KHz	1.0	5.63	0.35
6100-392K-RC	3900	0.9	100 KHz	252 KHz	0.9	6.62	0.32
6100-472K-RC	4700	0.8	100 KHz	252 KHz	0.8	8.23	0.29
6100-562K-RC	5600	0.7	100 KHz	252 KHz	0.7	9.45	0.27
6100-682K-RC	6800	0.6	100 KHz	252 KHz	0.6	13.2	0.24
6100-822K-RC	8200	0.5	100 KHz	252 KHz	0.5	16.0	0.22
6100-103K-RC	10,000	0.5	100 KHz	252 KHz	0.5	19.3	0.20
6100-123K-RC	12,000	0.4	100 KHz	252 KHz	0.4	23.2	0.19
6100-153K-RC	15,000	0.3	100 KHz	252 KHz	0.3	30.4	0.17
6100-183K-RC	18,000	0.3	100 KHz	79.6 KHz	0.3	34.1	0.16

General Specifications

Rated Current..... Inductance drop 5 %
 typical at I dc
 Operating Temperature
-40 °C to +105 °C
 Storage Temperature
-40 °C to +105 °C

Materials

Core Material..... Ferrite
 Wire Enameled copper
 Terminal Coating..... Sn

Marking

..... Value code on side of inductor

Packaging

Standard..... 160 pcs. per tray

Product Dimensions

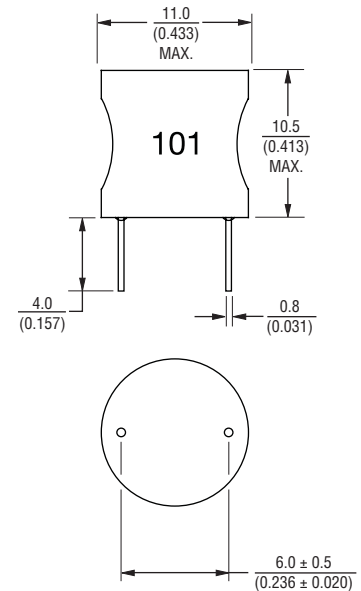

DIMENSIONS: $\frac{\text{MM}}{\text{(INCHES)}}$

Electrical Schematic

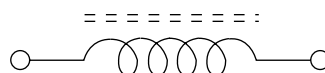

How To Order

Model _____
 Value Code (see table) _____
 Compliance Code _____
 RC = RoHS Compliant

Example: 6100-562K-RC = 5600 μ H, ± 10 %