



Features

- Formerly J. W. Miller® model
- Available in E6 series
- Low profile of only 5.0 mm
- Inductance as low as 1.0 µH
- RoHS compliant*

Applications

- Input/output of DC/DC converters
- Power supplies for:
 - Portable communication equipment
 - Camcorders
 - LCD TVs
 - Car radios

PM3316 Series - SMD Power Inductors

Electrical Specifications

Bourns Part No.	Inductance 1 kHz		Q Ref.	Test Frequency (MHz)	SRF Min. (MHz)	RDC (Ω)	I rms Max. (A)	I sat Typ. (A)
	(µH)	Tol. %						
PM3316-1R0M-RC	1	± 20	20	10	137	0.007	7.50	9.00
PM3316-1R5M-RC	1.5	± 20	50	3	95	0.009	6.50	8.00
PM3316-2R2M-RC	2.2	± 20	50	3	65	0.012	6.10	7.00
PM3316-3R3M-RC	3.3	± 20	50	4	54	0.015	5.00	6.40
PM3316-4R7M-RC	4.7	± 20	50	4	42	0.019	4.50	5.40
PM3316-6R8M-RC	6.8	± 20	50	3	31	0.030	3.40	4.50
PM3316-100M-RC	10	± 20	50	3	26	0.050	2.90	3.70
PM3316-150M-RC	15	± 20	50	3	22	0.060	2.50	3.00
PM3316-220M-RC	22	± 20	40	3	18	0.10	2.00	2.50
PM3316-330M-RC	33	± 20	25	1	14	0.12	1.80	2.00
PM3316-470M-RC	47	± 20	25	1	12	0.19	1.40	1.60
PM3316-680M-RC	68	± 20	25	1	11	0.24	1.20	1.40
PM3316-101M-RC	100	± 20	30	0.05	8	0.33	1.00	1.20
PM3316-151M-RC	150	± 20	30	0.05	6	0.59	0.80	1.00
PM3316-221M-RC	220	± 20	33	0.05	5	0.78	0.70	0.80
PM3316-331M-RC	330	± 20	33	0.05	4	1.15	0.55	0.60
PM3316-471M-RC	470	± 20	57	0.05	4	1.70	0.45	0.50
PM3316-681M-RC	680	± 20	57	0.05	3	2.60	0.35	0.40
PM3316-102M-RC	1000	± 20	81	0.07	2	3.90	0.30	0.35

General Specifications

Test Voltage 0.1 V
 Reflow soldering 250 °C; 10 sec max.
 (In compliance with JEDEC, J-STD-020C, Table 4-2)
 Operating Temperature -55 °C to +125 °C
 (Temperature rise included)
 Storage Temperature -55 °C to +125 °C
 Resistance to Soldering Heat 250 °C, 10 sec. max.

Materials

Core Ferrite DR
 Wire Enameled copper
 Base DAP
 Terminal Cu/Sn
 Rated Current Ind. drop 10 % typ. at Isat
 Temperature Rise 15 °C max. at rated I rms
 Packaging 500 pcs. per reel

Product Dimensions

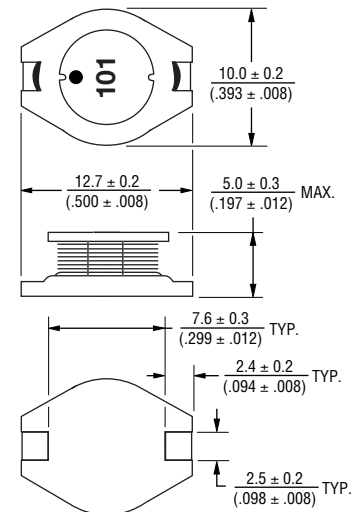

• = START OF WINDING

Recommended Layout

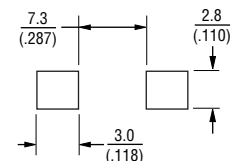

DIMENSIONS: $\frac{\text{MM}}{\text{(INCHES)}}$

*RoHS Directive 2002/95/EC Jan. 27, 2003 including annex and RoHS Recast 2011/65/EU June 8, 2011. Specifications are subject to change without notice. Customers should verify actual device performance in their specific applications..

PM3316 Series - SMD Power Inductors

BOURNS®

Soldering Profile

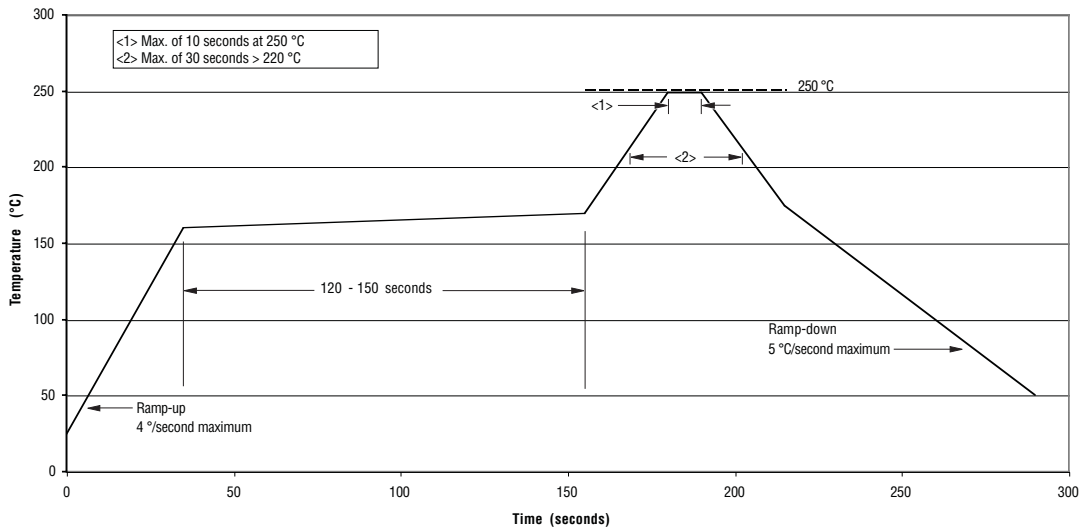

Packaging Specifications

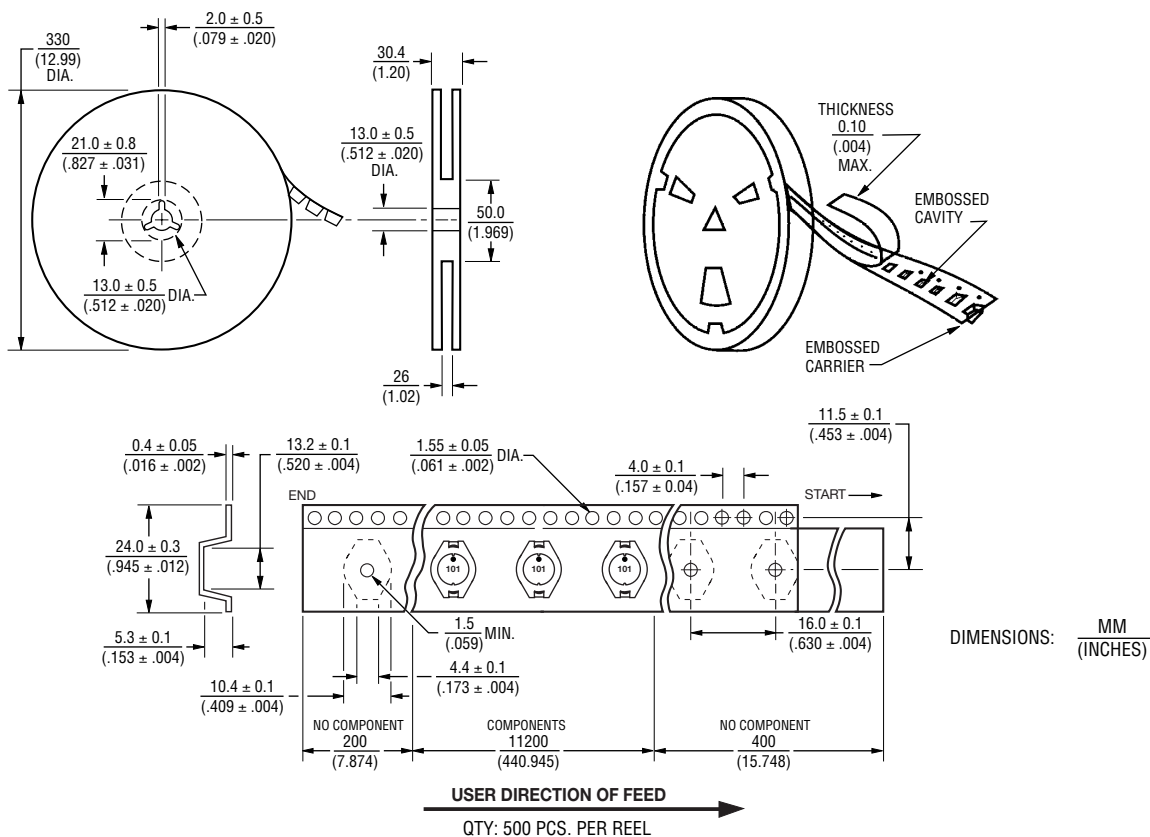

REV. 06/10

Specifications are subject to change without notice.
Customers should verify actual device performance in their specific applications..