

Features

- Non-contacting magnetic technology
- Highly resistant to vibration/shock
- Highly resistant to fluid/dust ingress
- Programmable at factory for zero position
- Robust design for industrial applications
- Highly repeatable

- RoHS compliant*

AMS22S Non-Contacting Analog Rotary Position Sensor

Electrical Characteristics¹ (@ 25 °C)

VDD Supply Voltage	5 V ± 10 %
Supply Current ²	
For Low Speed Processing (Code L)	10 mA max.
For High Speed Processing (Code H)	20 mA max.
Output Signal (Single)	Analog
Independent Linearity	±0.5 %
	(±0.3 % available on request)
Hysteresis	0.2 % VDD max.
Effective Electrical Angle ³	340 °
Programmable Electrical Angle	10 ° to 360 ° (10 ° increments)
Voltage Output (Programmable)	1 to 99 % VDD ±1 %
Output Resolution	12 bit @ 360 °
Load Resistance Recommended	10K ohms to ∞
Overvoltage Protection	+20 VDC
Reverse Voltage Protection	-10 VDC

Environmental Characteristics

Operating Temperature	-40 ° to +125 °C
Rotational Life (Shaft Revolutions)	50 million
Vibration	15 G
Shock	50 G
IP Rating	IP50
ESD Rating	2 kV max.

Mechanical Characteristics (@ 25 °C)

Mechanical Angle	Continuous
Shaft/RPM	120 RPM max.
Torque (Starting & Running)	1.06 N-cm. (1.5 oz-in.) max.
Shaft Material	Stainless steel
Terminals	Brass / 100 % matte tin over Ni Strike (e3)
Bearing	Bronze sleeve
Soldering Condition	
Manual Soldering	96.5Sn/3.0Ag/0.5Cu solid wire or no-clean rosin cored wire; 370 °C (700 °F) max. for 3 seconds
Wave Soldering	96.5Sn/3.0Ag/0.5Cu solder with no-clean flux; 260 °C (500 °F) max. for 5 seconds
Wash processes	Not recommended

¹At room ambient: +25 °C nominal and 50 % relative humidity nominal, except as noted.

² See "Processing Speed" in How to Order selection guide.

³ Other Effective Electrical Angles available. See How to Order selection guide.

Rotational Life vs. Shaft Side Load

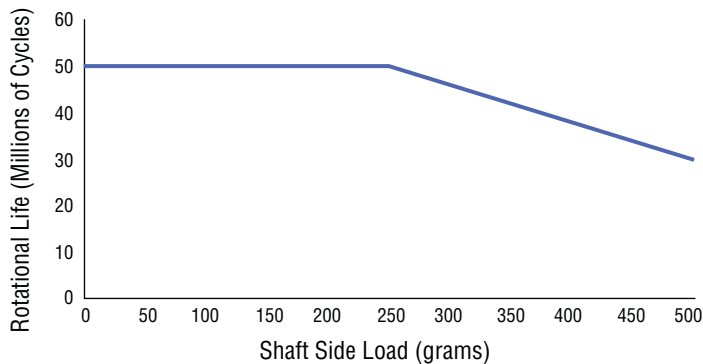

*RoHS Directive 2002/95/EC Jan. 27, 2003 including annex and RoHS Recast 2011/65/EU June 8, 2011. Specifications are subject to change without notice. Customers should verify actual device performance in their specific applications.

Product Dimensions

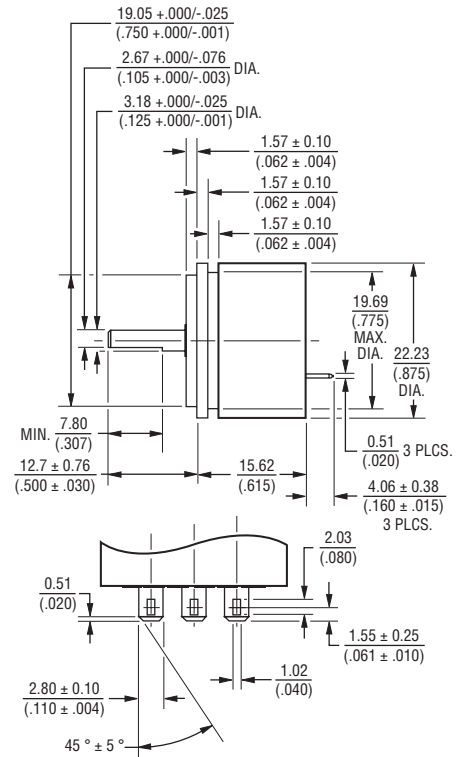
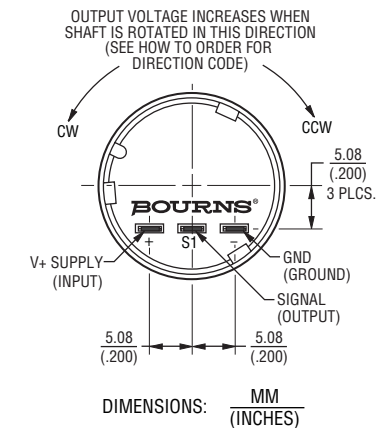
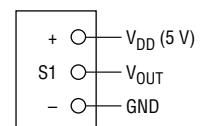

Figure 1



Schematic



AMS22S Non-Contacting Analog Rotary Position Sensor

BOURNS®

How To Order

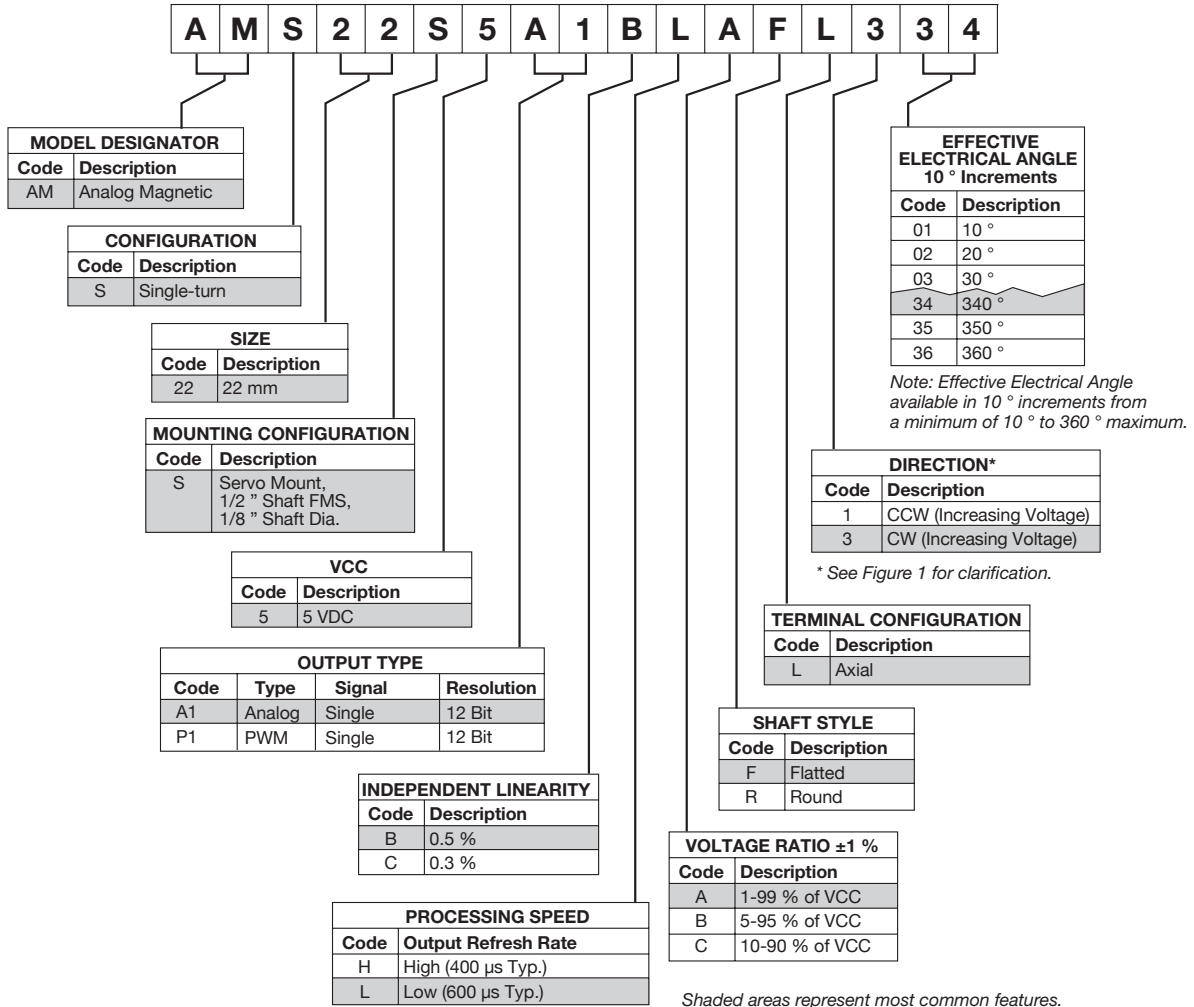

Standard Output: 1-Turn CW Increasing (Code 334 Shown)

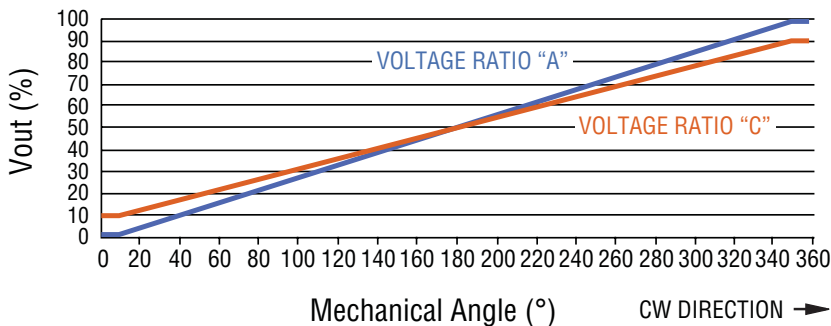

BOURNS®

Asia-Pacific:
Tel: +886-2 2562-4117
Fax: +886-2 2562-4116

Europe:
Tel: +41-41 768 5555
Fax: +41-41 768 5510

The Americas:
Tel: +1-951 781-5500
Fax: +1-951 781-5700

www.bourns.com

REV. 08/29/12

Specifications are subject to change without notice. Customers should verify actual device performance in their specific applications.