



Features

- Single pole/double throw
- Compatible with most surface mount manufacturing processes
- 50 or 2000 cycle rotational life
- Tape and reel packaged
- RoHS compliant* - see [processing information](#) on RoHS compliant surface mount components
- For switch applications/processing guidelines, [click here](#)

7813 SMD 3 mm Square Sealed Rotary Switch

Electrical Characteristics

Contact Rating	
Maximum Current.....	100 mA max.
Maximum Voltage.....	16 V
Contact Timing Non-shorting	
Contact Resistance	2 ohms max.
Insulation Resistance	
.....	100 megohms min.
Dielectric Strength	
.....	250 VAC

General Characteristics

Switch Type	SPDT
Operating Temperature Range	
.....	-55 °C to +125 °C
Storage Temperature Range	
.....	-55 °C to +125 °C
Seal Test.....	85 °C Fluorinert†

Mechanical Characteristics

Positions	2
Adjustment Torque.....	.5 N-cm max.
Stop Strength.....	1.8 N-cm min.

Environmental Characteristics

Shock	
.....	20 G
.....	0.1 ms max. discontinuity
Vibration	
.....	100 G
.....	0.1 ms max. discontinuity
Thermal Shock	
.....	(5 cycles)
.....	-55 °C to +125 °C

Humidity	
Insulation Resistance	
.....	10 megohms min.

Rotational Life	
-051	50 Cycles
-023	2000 Cycles

Standard Packaging	
J.....	1,000 pcs./reel
S	200 pcs./reel

How to Order

7813 J - 1 - 051 E

Model	_____
Terminal	_____
Switch Type	_____
1 = SPDT	
Rotational Life	_____
-051 = 50 Cycles	
-023 = 2000 Cycles	
Embossed Tape	_____
E = 1000 Pcs./180 mm Reel (J Style)	
200 Pcs./180 mm Reel (S Style)	

Product Dimensions

7813J

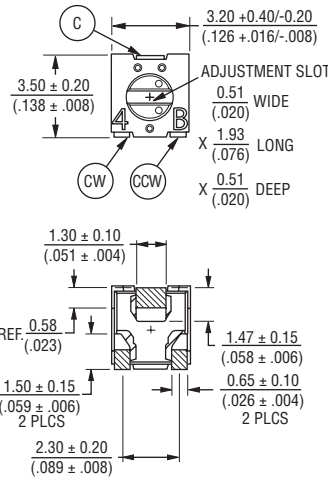

RECOMMENDED LAND PATTERN

7813S

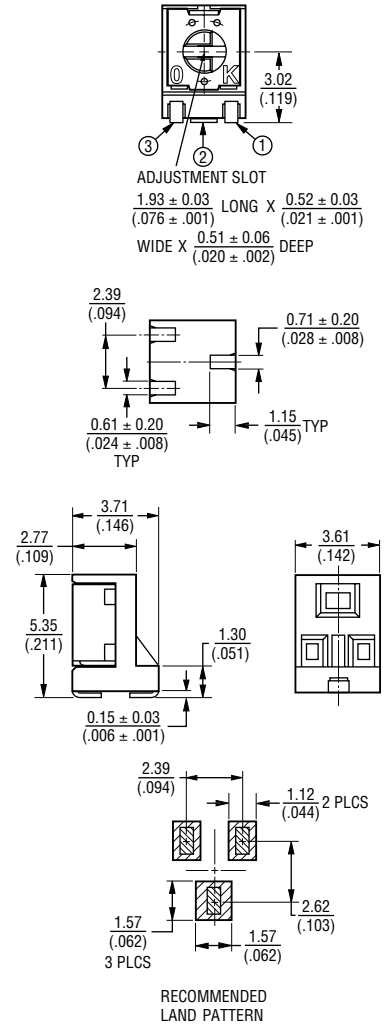

RECOMMENDED LAND PATTERN

DIMENSIONS: $\frac{\text{MM}}{\text{(INCHES)}}$

TOLERANCES: ±2 EXCEPT WHERE NOTED.

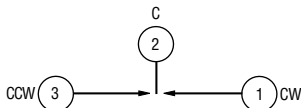

*RoHS Directive 2002/95/EC Jan. 27, 2003 including annex and RoHS Recast 2011/65/EU June 8, 2011.

†"Fluorinert" is a registered trademark of 3M Co.

Specifications are subject to change without notice.

Customers should verify actual device performance in their specific applications.

7813 SMD 3 mm Square Sealed Rotary Switch

BOURNS®

Packaging Specifications

7813J

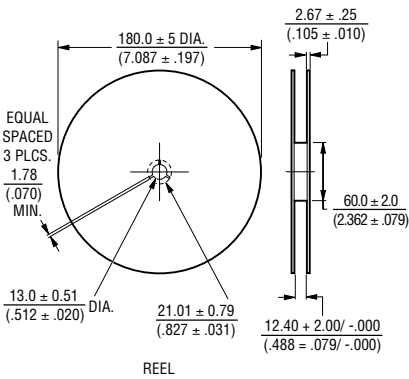
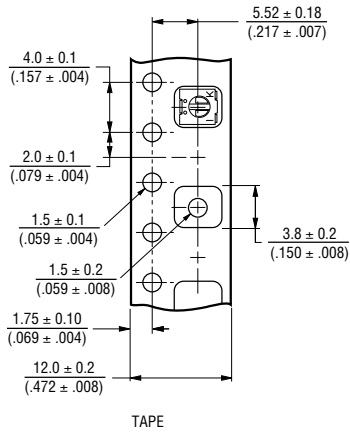
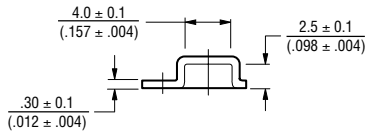

Meets EIA 481

7813S

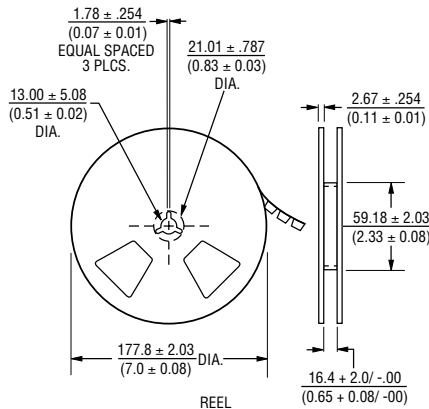
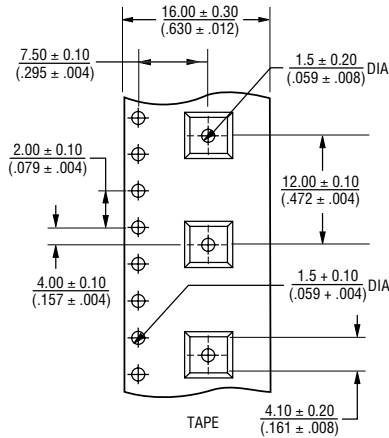
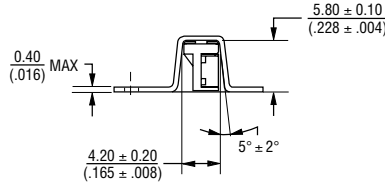

Meets EIA 481

DIMENSIONS: $\frac{\text{MM}}{\text{(INCHES)}}$

REV. 04/12

Specifications are subject to change without notice. Customers should verify actual device performance in their specific applications.