

*ROHS COMPLIANT



BOURNS®

Features

- Single-turn (3851 and 3852)
- Linear and audio tapers
- 3-3/4-turn (3856)
- Wide resistance range
- Minimal depth package
- Good resolution

3851/3852/3856 - 3/4 " Diameter Panel Control

Initial Electrical Characteristics¹

	3851 Conductive Plastic Element	3852/3856 Cermet Element
Standard Resistance Range		
Linear Tapers (A, B, E, and H)	1 K to 1 megohm	100 ohms to 1 megohm
Audio Tapers (C, D, F, and G)	1 K to 1 megohm	1 K ohms to 1 megohm
Total Resistance Tolerance	±10 % or ±20 %	±5 % or ±10 %
Independent Linearity	±10 %	(A & H tapers) ±5 %
Absolute Minimum Resistance	2 ohms maximum	2 ohms maximum
Effective Electrical Angle	250° ±5°	250° ±5°
Contact Resistance Variation	±1 %	±3 % of total resistance or 3 ohms (whichever is greater)
Dielectric Withstanding Voltage (MIL-STD-202, Method 301)		
Sea Level	900 VAC minimum	900 VAC minimum
70,000 Feet	350 VAC minimum	350 VAC minimum
Insulation Resistance (500 VDC)	1,000 megohms minimum	1,000 megohms minimum
Power Rating (Voltage Limited By Power Dissipation or 350 VAC, Whichever Is Less)		
+70 °C	(Linear tapers) 1 watt (Audio tapers) 0.5 watt	(Linear tapers) 2 watts (Audio tapers) 1 watt
+125 °C	0 watt	
+150 °C		0 watt
Theoretical Resolution	Essentially infinite	Essentially infinite

Environmental Characteristics¹

Operating Temperature Range	-1 °C to +125 °C	-1 °C to +125 °C
Storage Temperature Range	-65 °C to +125 °C	-65 °C to +150 °C
Temperature Coefficient Over Storage Temperature Range	±1,000 ppm/°C	±150 ppm/°C
Vibration	20 G	20 G
Total Resistance Shift	±2 % maximum	±2 % maximum
Voltage Ratio Shift	±5 % maximum	±6 % maximum
Shock	100 G	100 G
Total Resistance Shift	±2 % maximum	±2 % maximum
Voltage Ratio Shift	±5 % maximum	±6 % maximum
Load Life	1,000 hours	1,000 hours
Total Resistance Shift	±10 % maximum	±3 % maximum
Rotational Life (No Load)	100,000 cycles	50,000 cycles
Total Resistance Shift	±15 % TRS maximum	±5 % or 5 ohms TRS whichever is greater
Contact Resistance Variation	±3 %	±3 %
Moisture Resistance (MIL-STD-202, Method 103, Condition B)		
Total Resistance Shift	±10 % maximum	±2 % maximum
IP Rating	IP 40	IP 40

Mechanical Characteristics¹

Stop Strength	56.5 N-cm (5 lb.-in.)
Mechanical Angle	280° ±5° / 3856 - 1350° ±50°
Torque (Starting and Running)	A & B bushings 0.35 to 4.23 N-cm (0.05 to 6.0 oz.-in.) C & E bushings 0.21 to 4.23 N-cm (0.3 to 6.0 oz.-in.) 3856 - 0.11 to 2.12 N-cm (0.15 to 3.0 oz.-in.)
Mounting (Torque on Bushing)	1.7-2.0 N-m (15-18 lb.-in.) maximum
Weight (Single Section)	30 grams maximum
Terminals	Printed circuit terminals or solder lugs
Soldering Condition	Recommended hand soldering using Sn95/Ag5 no clean solder, 0.025 " wire diameter. Maximum temperature 399 °C (750 °F) for 3 seconds. No wash process to be used with no clean flux. Part can be wave soldered at 260 °C (500 °F) for 5 seconds, no wash process with no clean flux.
Marking	Manufacturer's trademark, wiring diagram, resistance, date code, and part number
Ganging (Multiple Section Potentiometers)	1 cup maximum
Hardware	One lockwasher and one mounting nut is shipped with each potentiometer, except where noted in the part number.

¹AT ROOM AMBIENT: +25 °C NOMINAL AND 50 % RELATIVE HUMIDITY NOMINAL, EXCEPT AS NOTED.

*RoHS Directive 2002/95/EC Jan 27 2003 including Annex

Specifications are subject to change without notice.

Customers should verify actual device performance in their specific applications.

3851/3852/3856 - 3/4 " Diameter Panel Control

BOURNS®

Product Dimensions

3851A/3852A

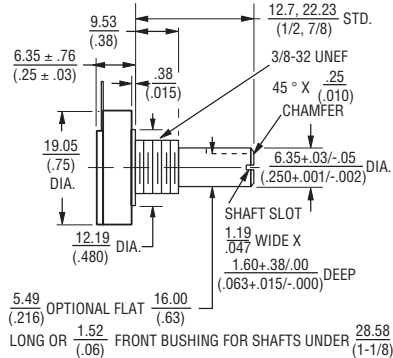

3851B/3852B

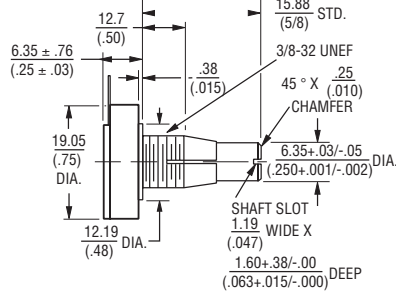

Terminal Configuration

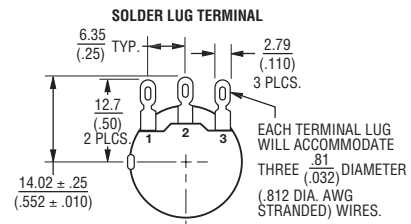

3851C/3852C

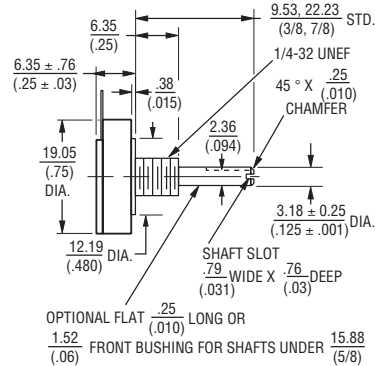

3851E/3852E

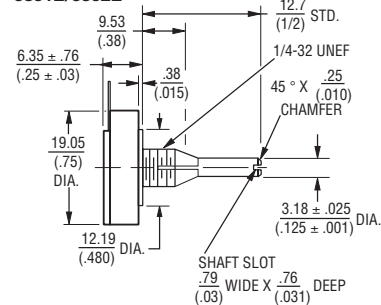

SUGGESTED BOARD LAYOUT

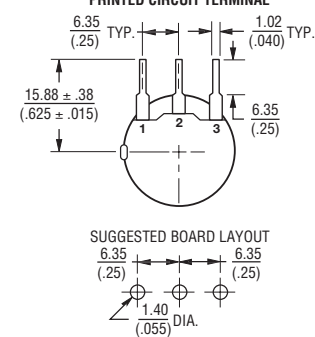

3851/3852/3856

A, B & H BUSHINGS

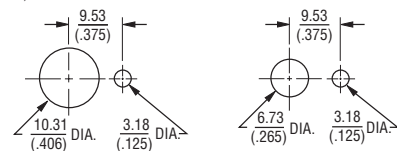

3856A

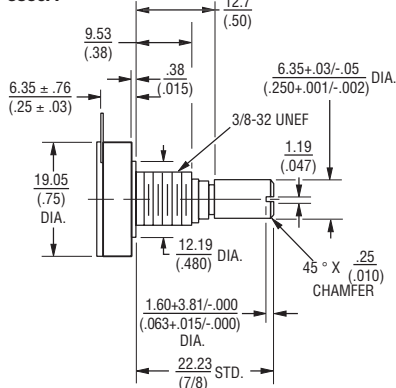

3856H

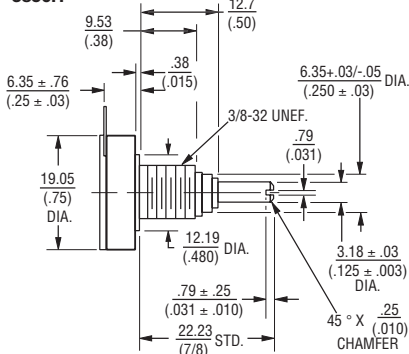

Shaft End Detail

3850 Family

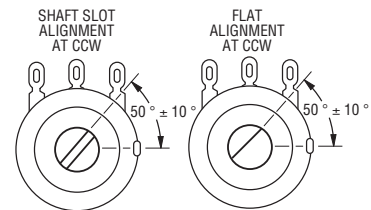

TOLERANCES EXCEPT AS NOTED:
 DECIMALS: .XXX ± .127 (.005), .XX ± .38 (.015)
 FRACTIONS: ± 1/64
 ANGLE: ± 3%

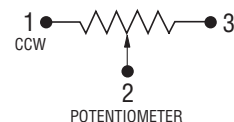

DIMENSIONS ARE: $\frac{\text{MM}}{\text{(INCHES)}}$

3851/3852/3856 - 3/4 " Diameter Panel Control

BOURNS®

How To Order

3852 A - 28 2 - 103 A L

	SHAFT TYPE (FMS) & DIAMETER	AVAILABLE ONLY IN	
		MODELS	BUSHINGS
12	3/8 " (9.53 mm) L X 1/8 " (3.18 mm) D	3851, 3852	C
16	1/2 " (12.7 mm) L x 1/4 " (6.35 mm) D	3851, 3852	A
16	1/2 " (12.7 mm) L x 1/8 " (3.18 mm) D	3851, 3852	C, E
20	5/8 " (15.88 mm) L X 1/4 " (6.35 mm) D	3851, 3852	A, B
28	7/8 " (22.20 mm) L X 1/4 " (6.35 mm) D	3851, 3852 3856	A, B A
		3851, 3852	C, E
28	7/8 " (22.20 mm) L X 1/8 " (3.18 mm) D	3856	H

Consult factory for lengths not shown.

	BUSHING	APPLICABLE MODELS
A	Plain 3/8 " (9.53 mm) D x 3/8 " (9.53 mm) L	3851, 3852, 3856
B	Locking 3/8 " (9.53 mm) D x 1/2 " (12.7 mm) L	3851, 3852
C	Plain 1/4 " (6.35 mm) D x 1/4 " (6.35 mm) L	3851, 3852
E	Locking 1/4 " (6.35 mm) D x 1/2 " (12.7 mm) L	3851, 3852
H	Plain 3/8 " (9.53 mm) D x 3/8 " (9.53 mm) L	3856 (3.18 mm D Shaft)

RESISTANCE CODE/VALUE (IN OHMS)	
Model 3851	
(102)	1 K
(252)	2.5 K
(502)	5 K
(103)	10 K
(253)	25 K
(503)	50 K
(104)	100 K
(254)	250 K
(504)	500 K
(105)	1 M
Models 3852/3856	
(101)	100
(251)	250
(501)	500
(102)	1 K
(252)	2.5 K
(502)	5 K
(103)	10 K
(253)	25 K
(503)	50 K
(104)	100 K
(254)	250 K
(504)	500 K
(105)	1 M

RoHS IDENTIFIER	
L	Compliant

MODEL	
3851	3/4 " (19.05 mm) D Single-Turn C.P.
3852	3/4 " (19.05 mm) D Single-Turn Cermet
3856	3/4 " (19.05 mm) D 3-3/4-Turn Cermet

TERMINAL STYLE AND SHAFT TYPE	
1	Solder Lugs, Plain End
2	Solder Lugs, Slotted End
3	Solder Lugs, Flatted Shaft
5	PC Pins, Plain End
6	PC Pins, Slotted End
7	PC Pins, Flatted Shaft

ELEMENT TAPER/TOLERANCE	APPLICABLE MODELS
A Linear ± 10 %	3852, 3856
B Linear ± 20 %	3851
C Audio CW ± 10 %	3852, 3856
D Audio CW ± 20 %	3851
E Linear ± 10 %	3851
F Audio CCW ± 10 %	3852, 3856
G Audio CCW ± 20 %	3851
H Linear ± 5 %	3852, 3856

Boldface features are Bourns standard options. All others are available with higher minimum order quantities.