

**BOURNS®**

## Features

- Multi-stage protection
- Balanced TRIGARD®
- Quick response to surges
- High energy handling
- Reliability is improved by elimination of the air Back-Up-Gap (BUG)
- Meets test requirements of Telcordia GR 974, GR1361, SR 5165 and RUS PE-80
- Telcordia Analysis report DA-1843
- High-speed network compatible
- Binding post or optional Insulation Displacement Connectors (IDC)
-  UL Listed per UL 497 (File: E53117)

## 2377-45 Series Digi.Guard – MSP® Maximum Duty Station Protector

Bourns® Model 455HS Multi-Stage Protector (MSP®) is a new generation telecommunications station protector designed to be the best all around choice for protecting copper pair voice-band and high-speed data circuits. Combining the strengths of Gas Discharge Tube (GDT) and solid state overvoltage protection, the Model 455HS MSP® integrates three advanced technologies: our proprietary advanced GDT, precision matched metal oxide varistors (MOV), and a patented Switch-Grade Fail-Short mechanism. The 2377 series offer superior service life, far exceeding Telcordia standards.

Bourns® 2377-45 can be used universally for POTS and high speed data, e.g. ISDN, ADSL, ADSL2+, VDSL, VDSL2, other xDSL protocols and high speed Ethernet. Bourns® MSP® technology provides unparalleled overvoltage protection with low loss on paired copper communications circuits. The Model 455 is the most economical, reliable and effective choice to protect paired copper communications circuits. The IDC version, with environmental sealant, provides additional ease of installation and protection against corrosion.

### Characteristics

Tested per IEEE C62.31, UL 497, CSA C22.2, Telcordia GR-1361 and applicable sections of Telcordia GR 974.

DC Breakdown .....	300-400 V
AC Breakdown .....	60 Hz ..... 300-400 V
Impulse Breakdown.....	100 V/μs ..... 600 V
	1000 V/μs ..... 650 V
Insulation Resistance .....	100 Vdc ..... > 1 GΩ
Insertion Loss .....	100 MHz ..... < 0.4 dB (Category 5)
Return Loss .....	100 MHz ..... > 14 dB (Category 5)
Capacitance Line to Line - Binding Post.....	1 MHz ..... 12 pF typical
Capacitance Line to Line - IDC .....	1 MHz ..... 14 pF typical
Capacitance Line to Ground - Binding Post .....	1 MHz ..... 24 pF typical
Capacitance Line to Ground - IDC .....	1 MHz ..... 28 pF typical
Impulse Reset <sup>1</sup> .....	52 V, 260 mA ..... < 10 ms <sup>3</sup>
	135 V, 200 mA ..... < 10 ms <sup>3</sup>
	150 V, 200 mA ..... < 150 ms
Impulse Life Characteristics	
(Per-Side, Simultaneously) .....	100 A, 10/1000 μs ..... > 3000 operations <sup>2</sup>
	300 A, 10/1000 μs ..... > 1000 operations <sup>2</sup>
	500 A, 10/1000 μs ..... > 1000 operations <sup>4</sup>
	2,000 A, 10/250 μs ..... > 100 operations <sup>2</sup>
	5,000 A, 20/100 μs ..... > 10 operations <sup>2</sup>
	20,000 A, 8/20 μs ..... > 10 operations <sup>4</sup>
AC Life Characteristics.....	0.5 A rms continuous ..... > 30 seconds
	1 A rms, 1 second, 600 ft. cable ..... > 60 operations
	1 A rms, 1 second, 1 mile cable..... > 60 operations
	10 A rms, 1 second ..... > 20 operations
	200 A rms, 11 cycles..... 1 operation <sup>5</sup>
	120 A rms, 0.1 second ..... 1 operation
Life Test Criteria	
Insulation Resistance Throughout the Life Test .....	100 MΩ
Life Test Failures.....	0.0 %
Failures During Environmental Cycling w/ surges .....	0.0 %
Fail-Short (vented or non-vented gas tube) .....	> 30 Arms, simultaneously
Operating Temperature .....	-55 to +85 °C

### Notes:

<sup>1</sup> Network Applied

<sup>2</sup> Exceeds Telcordia (Bellcore) GR 1361

<sup>3</sup> Surpasses Telcordia GR 974

<sup>4</sup> RUS (REA) PE-80

<sup>5</sup> Protector may short to ground

Line to Line voltage is approximately 1.8 to 2 times the stated Line to Ground breakdown voltage.

# 2377-45 Series Digi.Guard – MSP® Maximum Duty Station Protector

**BOURNS®**

## Product Dimensions

### 2377-45-HS, 2377-45-BC

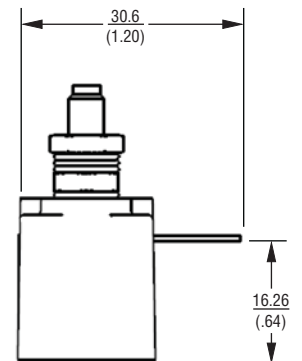
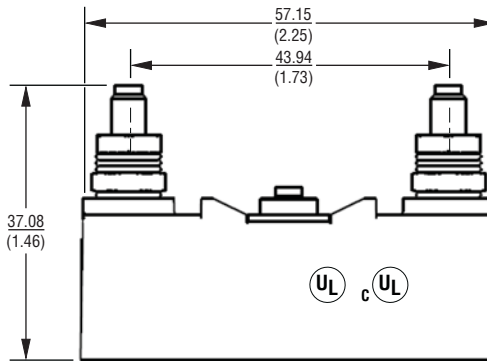
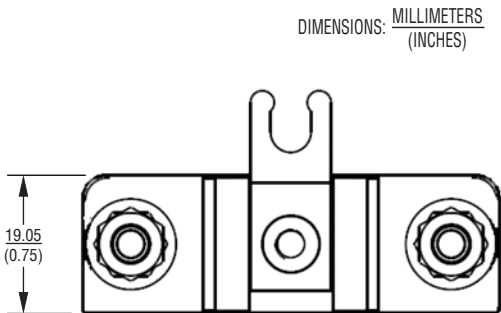

### 2377-45-HS-IDC, 2377-45-BC-IDC

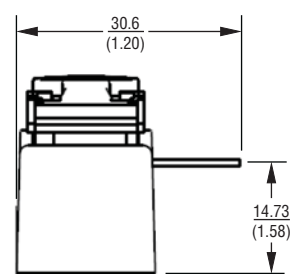
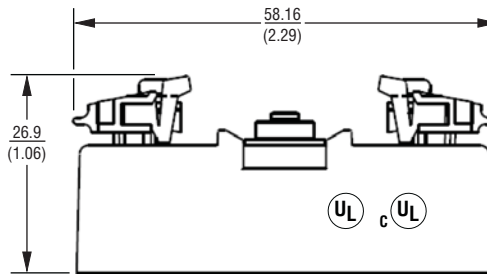
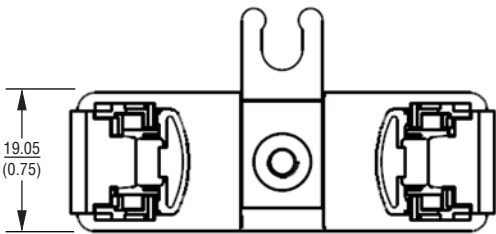

### 2372-02 Ground Mounting Stud (order separately)

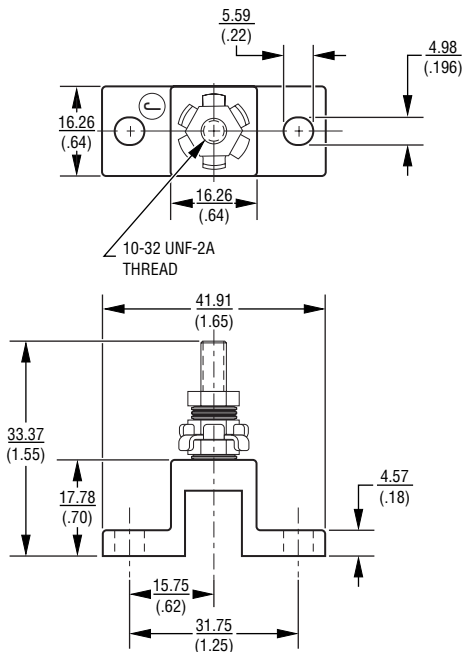

## How To Order

- 2377-45-HS ..... Binding Post Connectors  
 2377-45-BC\* ..... Balanced Capacitance,  
 Binding Post Connectors  
 2377-45-HS-IDC ..... Insulation Displacement Connectors  
 2377-45-BC-IDC\* ..... Balanced Capacitance,  
 Insulation Displacement Connectors

\* BC versions for xDSL systems that require Tip-to-Ground and Ring-to-Ground capacitive balance of  $\leq 1$  pF.

## Related Products

-  80052 ..... Test Clip for IDC  
 80053 ..... Insulation Tool for IDC

REV. M 07/11

Specifications are subject to change without notice.  
 Customers should verify actual device performance in their specific applications.