

CZT2955 PNP
CZT3055 NPN

**SURFACE MOUNT
COMPLEMENTARY
SILICON POWER TRANSISTORS**



www.centrasemi.com

**POWER
223**



SOT-223 CASE

DESCRIPTION:

The CENTRAL SEMICONDUCTOR CZT2955 and CZT3055 types are surface mount epoxy molded complementary silicon transistors manufactured by the epitaxial base process, designed for surface mounted power amplifier applications up to 6.0 amps.

MARKING: FULL PART NUMBER

MAXIMUM RATINGS: ($T_A=25^\circ\text{C}$)

	SYMBOL		UNITS
Collector-Base Voltage	V_{CBO}	100	V
Collector-Emitter Voltage	V_{CER}	70	V
Collector-Emitter Voltage	V_{CEO}	60	V
Emitter-Base Voltage	V_{EBO}	7.0	V
Continuous Collector Current	I_C	6.0	A
Continuous Base Current	I_B	3.0	A
Power Dissipation	P_D	2.0	W
Operating and Storage Junction Temperature	T_J, T_{stg}	-65 to +150	$^\circ\text{C}$
Thermal Resistance	Θ_{JA}	62.5	$^\circ\text{C/W}$

ELECTRICAL CHARACTERISTICS: ($T_A=25^\circ\text{C}$ unless otherwise noted)

SYMBOL	TEST CONDITIONS	MIN	MAX	UNITS
I_{CEO}	$V_{CE}=30\text{V}$		700	μA
I_{CEV}	$V_{CE}=100\text{V}, V_{EB}=1.5\text{V}$		1.0	mA
I_{EBO}	$V_{EB}=7.0\text{V}$		5.0	mA
BV_{CER}	$I_C=30\text{mA}, R_{BE}=100\Omega$	70		V
BV_{CEO}	$I_C=30\text{mA}$	60		V
$V_{CE(SAT)}$	$I_C=4.0\text{A}, I_B=400\text{mA}$		1.1	V
$V_{BE(ON)}$	$V_{CE}=4.0\text{V}, I_C=4.0\text{A}$		1.5	V
h_{FE}	$V_{CE}=4.0\text{V}, I_C=4.0\text{A}$	20	70	
h_{FE}	$V_{CE}=4.0\text{V}, I_C=6.0\text{A}$	5.0		
f_T	$V_{CE}=10\text{V}, I_C=500\text{mA}, f=1.0\text{MHz}$	2.5		MHz

CZT2955 PNP
CZT3055 NPN

**SURFACE MOUNT
COMPLEMENTARY
SILICON POWER TRANSISTORS**



SOT-223 CASE - MECHANICAL OUTLINE

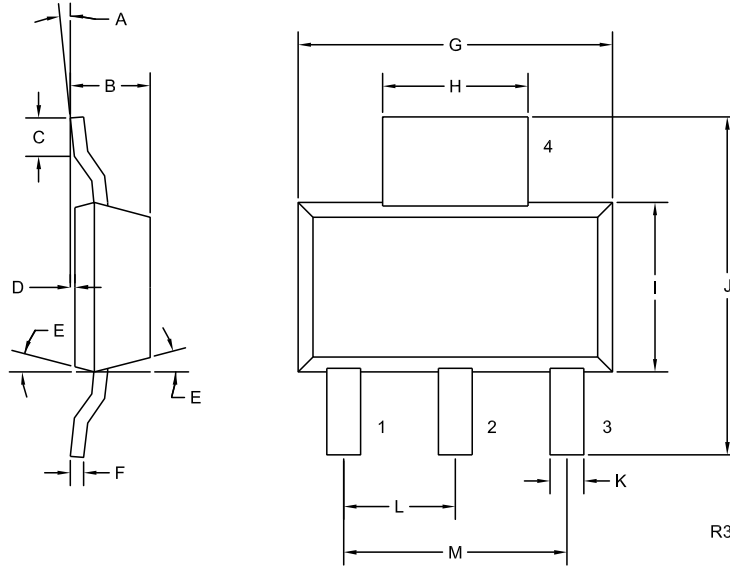

LEAD CODE:

- 1) Base
- 2) Collector
- 3) Emitter
- 4) Collector

**MARKING:
FULL PART NUMBER**

SYMBOL	DIMENSIONS			
	INCHES		MILLIMETERS	
	MIN	MAX	MIN	MAX
A	0°	10°	0°	10°
B	0.059	0.071	1.50	1.80
C	0.018	—	0.45	—
D	0.000	0.004	0.00	0.10
E	15°		15°	
F	0.009	0.014	0.23	0.35
G	0.248	0.264	6.30	6.70
H	0.114	0.122	2.90	3.10
I	0.130	0.146	3.30	3.70
J	0.264	0.287	6.70	7.30
K	0.024	0.033	0.60	0.85
L	0.091		2.30	
M	0.181		4.60	

SOT-223 (REV: R3)

R4 (1-March 2010)