

CZTA27

**SURFACE MOUNT
HIGH VOLTAGE NPN
SILICON DARLINGTON TRANSISTOR**



SOT-223 CASE



www.centrasemi.com

DESCRIPTION:

The CENTRAL SEMICONDUCTOR CZTA27 type is a NPN Silicon Darlington Transistor manufactured by the epitaxial planar process, epoxy molded in a surface mount package, designed for applications requiring extremely high gain and high voltage.

MARKING: FULL PART NUMBER

MAXIMUM RATINGS: ($T_A=25^{\circ}\text{C}$)

Collector-Emitter Voltage
Emitter-Base Voltage
Continuous Collector Current
Power Dissipation
Operating and Storage Junction Temperature
Thermal Resistance

SYMBOL

V_{CES} 60
 V_{EBO} 10
 I_C 500
 P_D 2.0
 T_J, T_{stg} -65 to +150
 θ_{JA} 62.5

UNITS

V
V
mA
W
 $^{\circ}\text{C}$
 $^{\circ}\text{C/W}$

ELECTRICAL CHARACTERISTICS: ($T_A=25^{\circ}\text{C}$ unless otherwise noted)

SYMBOL	TEST CONDITIONS	MIN	MAX	UNITS
I_{CBO}	$V_{CB}=50\text{V}$		100	nA
I_{CES}	$V_{CE}=50\text{V}$		500	nA
I_{EBO}	$V_{EB}=10\text{V}$		100	nA
BV_{CBO}	$I_C=100\mu\text{A}$	60		V
BV_{CES}	$I_C=100\mu\text{A}$	60		V
$V_{CE(SAT)}$	$I_C=100\text{mA}, I_B=0.1\text{mA}$		1.5	V
$V_{BE(ON)}$	$V_{CE}=5.0\text{V}, I_C=100\text{mA}$		2.0	V
h_{FE}	$V_{CE}=5.0\text{V}, I_C=10\text{mA}$	10,000		
h_{FE}	$V_{CE}=5.0\text{V}, I_C=100\text{mA}$	10,000		
f_T	$V_{CE}=5.0\text{V}, I_C=10\text{mA}, f=100\text{MHz}$	125		MHz

R3 (1-March 2010)

CZTA27
SURFACE MOUNT
HIGH VOLTAGE NPN
SILICON DARLINGTON TRANSISTOR



SOT-223 CASE - MECHANICAL OUTLINE

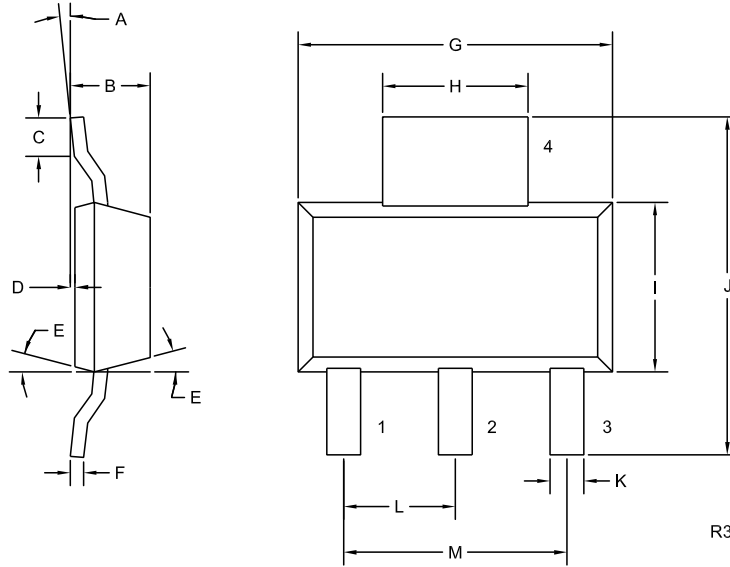

LEAD CODE:

- 1) Base
- 2) Collector
- 3) Emitter
- 4) Collector

MARKING:

FULL PART NUMBER

SYMBOL	INCHES		MILLIMETERS	
	MIN	MAX	MIN	MAX
A	0°	10°	0°	10°
B	0.059	0.071	1.50	1.80
C	0.018	—	0.45	—
D	0.000	0.004	0.00	0.10
E	15°		15°	
F	0.009	0.014	0.23	0.35
G	0.248	0.264	6.30	6.70
H	0.114	0.122	2.90	3.10
I	0.130	0.146	3.30	3.70
J	0.264	0.287	6.70	7.30
K	0.024	0.033	0.60	0.85
L	0.091		2.30	
M	0.181		4.60	

SOT-223 (REV: R3)

R3 (1-March 2010)