

CMUT5087E PNP
CMUT5088E NPN

**ENHANCED SPECIFICATION
SURFACE MOUNT
COMPLEMENTARY
SILICON TRANSISTORS**

ULTRAmⁱⁿⁱ[™]

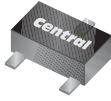

SOT-523 CASE



www.centrasemi.com

DESCRIPTION:

The CENTRAL SEMICONDUCTOR CMUT5087E and CMUT5088E are Silicon transistors in an ULTRAmⁱⁿⁱ[™] surface mount package with enhanced specifications designed for applications requiring high gain and low noise.

**MARKING CODES: CMUT5087E: U87
CMUT5088E: U88**

MAXIMUM RATINGS: (T_A=25°C)

- ◆ Collector-Base Voltage
- ◆ Collector-Emitter Voltage
- ◆ Emitter-Base Voltage
- Continuous Collector Current
- Power Dissipation
- Operating and Storage Junction Temperature
- Thermal Resistance

SYMBOL

SYMBOL	UNITS
V _{CB0}	V
V _{CEO}	V
V _{EBO}	V
I _C	mA
P _D	mW
T _J , T _{stg}	°C
θ _{JA}	°C/W

ELECTRICAL CHARACTERISTICS: (T_A=25°C unless otherwise noted)

SYMBOL	TEST CONDITIONS	TYP			UNITS
		MIN	NPN	PNP	
I _{CB0}	V _{CB} =20V				50 nA
I _{EBO}	V _{EB} =3.0V				50 nA
◆ BV _{CB0}	I _C =100μA	50	135	150	V
◆ BV _{CEO}	I _C =1.0mA	50	65	105	V
◆ BV _{EBO}	I _E =100μA	5.0	8.7	7.5	V
◆ V _{CE(SAT)}	I _C =10mA, I _B =1.0mA		45	50	100 mV
◆◆ V _{CE(SAT)}	I _C =100mA, I _B =10mA		110	225	400 mV
V _{BE(SAT)}	I _C =10mA, I _B =1.0mA		700	700	800 mV
◆ h _{FE}	V _{CE} =5.0V, I _C =0.1mA	300	430	390	900
h _{FE}	V _{CE} =5.0V, I _C =1.0mA	300	435	380	
◆ h _{FE}	V _{CE} =5.0V, I _C =10mA	300	430	350	
◆◆ h _{FE}	V _{CE} =5.0V, I _C =100mA	50	125	75	
◆ f _T	V _{CE} =5.0V, I _C =500μA, f=20MHz	100			MHz
C _{ob}	V _{CB} =5.0V, I _E =0, f=1.0MHz				4.0 pF
C _{ib}	V _{BE} =0.5V, I _C =0, f=1.0MHz				15 pF
h _{fe}	V _{CE} =5.0V, I _C =1.0mA, f=1.0kHz	350			1400
NF	V _{CE} =5.0V, I _C =100μA, R _S =10kΩ f=10Hz to 15.7kHz			3.0	dB

- ◆ Enhanced specification
- ◆◆ Additional Enhanced specification

R2 (9-February 2010)

CMUT5087E PNP
 CMUT5088E NPN

**ENHANCED SPECIFICATION
 SURFACE MOUNT
 COMPLEMENTARY
 SILICON TRANSISTORS**



SOT-523 CASE - MECHANICAL OUTLINE

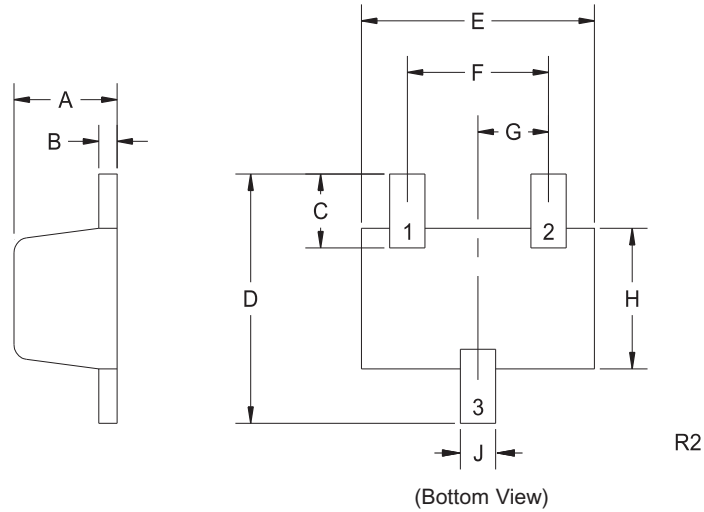

LEAD CODE:

- 1) Base
- 2) Emitter
- 3) Collector

MARKING CODES:

CMUT5087E: U87
 CMUT5088E: U88

SYMBOL	INCHES		MILLIMETERS	
	MIN	MAX	MIN	MAX
A	0.023	0.031	0.58	0.78
B	0.002	0.008	0.04	0.20
C	0.013	0.021	0.34	0.54
D	0.059	0.067	1.50	1.70
E	0.059	0.067	1.50	1.70
F	0.035	0.043	0.90	1.10
G	0.020		0.50	
H	0.031	0.039	0.78	0.98
J	0.010	0.014	0.25	0.35

SOT-523 (REV: R2)

R2 (9-February 2010)