

Features

- Low skew: < 200ps
- Fast switching frequency > 133 MHz
- Fast output rise/fall time < 1.5ns
- Low propagation delay < 2.5ns
- Low input capacitance < 6.0pF
- 5V Tolerant input
- Rail-to-Rail CMOS outputs
- Industrial Temperature: -40°C to +85°C
- 3.3V ±10% operation
- Packages (Pb-free & Green available):
 - 16-pin 150-mil wide QSOP (Q)
 - 16-pin 173-mil wide TSSOP (L)

Block Diagram (PI49FCT32802)

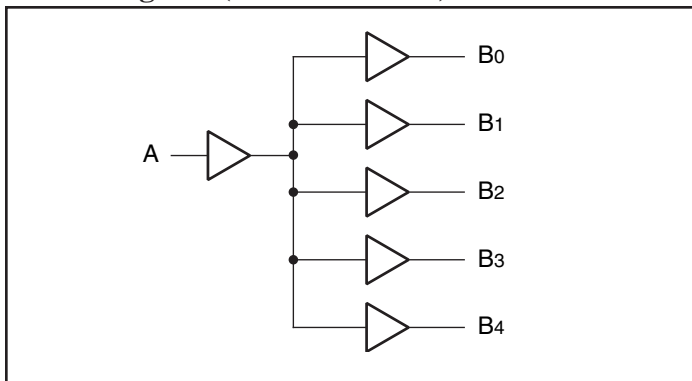

Block Diagram (PI49FCT32803)

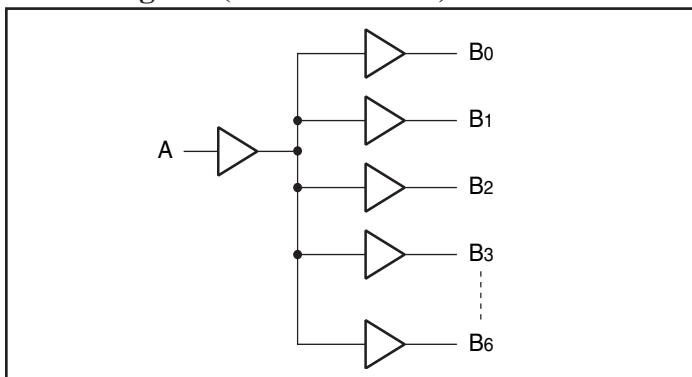

Description

Pericom Semiconductor's PI49FCT3280x is a 3.3V very low-skew clock buffer from a single low-capacitance input that produces five outputs on PI49FCT32802 and seven outputs on PI49FCT32803. Excellent output signals to power and ground ratio minimize power and ground noise, and also improves output performance.

The PI49FCT3280x integrates series damping resistors on all outputs.

Pin Configuration (PI49FCT32802)

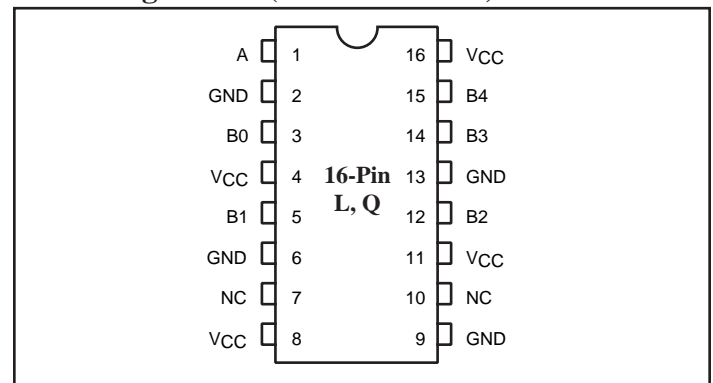

Pin Configuration (PI49FCT32803)

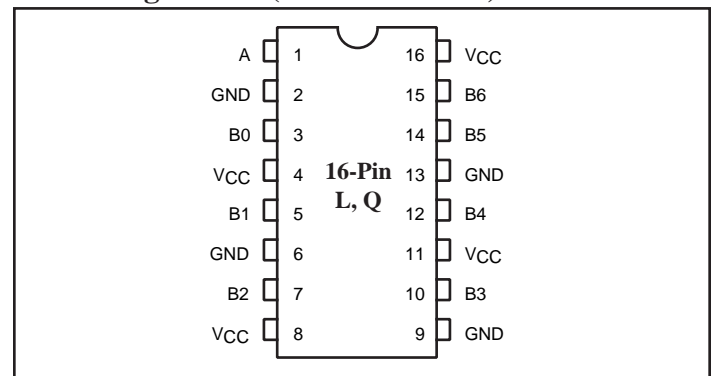

Pin Description

Pin Name		Description
PI49FCT32802	PI49FCT32803	
A	A	Input
B0-B4	B0-B6	Outputs
GND	GND	Ground
VCC	VCC	Power

Maximum Ratings

(Above which the useful life may be impaired. For user guidelines, not tested.)

Storage Temperature	-65°C to +150°C
Ambient Temperature with Power Applied	-40°C to +85°C
Supply Voltage to Ground Potential.....	-0.5V to +5.5V
DC Input Voltage	-0.5V to +5.5V
DC Output Current.....	120mA
Power Dissipation	0.5W

Note:

Stresses greater than those listed under MAXIMUM RATINGS may cause permanent damage to the device. This is a stress rating only and functional operation of the device at these or any other conditions above those indicated in the operational sections of this specification is not implied. Exposure to absolute maximum rating conditions for extended periods may affect reliability.

DC Electrical Characteristics (Over the Operating Range)

Symbol	Description	Test Conditions ⁽¹⁾		Min.	Typ.	Max.	Units
V _{OH}	Output HIGH voltage	V _{CC} =3V, V _{IN} =V _{IH} or V _{IL}	I _{OH} = -8mA	2.4	3	-	V
V _{OL}	Output LOW voltage	V _{CC} =3V, V _{IN} =V _{IH} or V _{IL}	I _{OL} = 12mA	-	0.4	0.5	
V _{IH}	Input HIGH voltage	Guaranteed Logic HIGH Level (Input Pins)		2	-	5.5	
V _{IL}	Input LOW voltage	Guaranteed Logic LOW Level (Input Pins)		-0.5	-	0.8	
I _{IH}	Input HIGH current	V _{CC} = 3.6V	V _{IN} = 3.6V	-	-	1	μA
I _{IL}	Input LOW current	V _{CC} = 3.6V	V _{IN} = 0V	-	-	-1	
V _{IK}	Clamp diode voltage	V _{CC} = Min., I _{IN} = -18mA		-	-0.7	-1.2	V
I _{OH}	Output HIGH current	V _{CC} = 3.3V, V _{IN} = V _{IH} or V _{IL} , V _{OUT} = 1.5V ⁽⁵⁾		-25	-45	-80	mA
I _{OL}	Output LOW current	V _{CC} = 3.3V, V _{IN} = V _{IH} or V _{IL} , V _{OUT} = 1.5V ⁽⁵⁾		25	45	90	
I _{OS}	Short circuit current ⁽⁵⁾	V _{CC} = Max., V _{OUT} = GND ⁽⁵⁾		-50	-100	-180	
V _H	Input Hysteresis			-	150	-	mV
R _S	Series Resistor				22		Ω

Notes:

- For Max. or Min. conditions, use appropriate value specified under Electrical Characteristics for the applicable device type.
- Typical values are at V_{CC} = 3.3V, +25°C ambient and maximum loading.
- V_{OH} = V_{CC} - 0.6V at rated current.
- This parameter is determined by device characterization but is not production tested.
- Not more than one output should be shorted at one time. Duration of the test should not exceed one second.

Power Supply Characteristics

Parameters	Description	Test Conditions ⁽¹⁾		Min.	Typ ⁽²⁾	Max.	Units
I _{CC}	Quiescent Power Supply Current	V _{CC} = Max.	V _{IN} = GND or V _{CC}	—	0.1	30	μA
ΔI _{CC}	Supply Current per Inputs @ TTL HIGH	V _{CC} = Max.	V _{IN} = V _{CC} - 0.6V ⁽³⁾	—	47	300	
I _{CCD}	Supply Current per Input per MHz ⁽⁴⁾	V _{CC} = Max., Outputs Open Per Output Toggling 50% Duty Cycle	V _{IN} = V _{CC}	—			mA/
			V _{IN} = GND		0.08	0.16	MHz

Notes:

- For Max. or Min. conditions, use appropriate value specified under Electrical Characteristics for the applicable device.
- Typical values are at V_{CC} = 3.3V, +25°C ambient.
- Per TTL driven input (V_{IN} = V_{CC} - 0.6V); all other inputs at V_{CC} or GND.
- This parameter is not directly testable, but is derived for use in Total Power Supply Calculations.
- Values for these conditions are examples of the I_C formula. These limits are guaranteed but not tested.

Capacitance (T_A = 25°C, f = 1 MHz)

Parameters ⁽¹⁾	Description	Test Conditions	Typ	Max.	Units
C _{IN}	Input Capacitance	V _{IN} = 0V	3.0	4	pF
C _{OUT}	Output Capacitance	V _{OUT} = 0V		6	

Notes:

- This parameter is determined by device characterization but is not production tested.

Maximum Switching Characteristics (Over operating range)

Symbol	Description	Condition	Max.	Units
t _{PLH} t _{PHL}	Propagation Delay A to Bn ⁽³⁾	CL = 15pF	2.5	ns
t _R /t _F	Rise/Fall Time ⁽²⁾	0.8V - 2.0V	1.5	
t _{SK(p)}	Pulse Skew (same pkg) ^(1,2)	CL = 15pF	0.35	
t _{SK(o)}	Output Skew (same pkg.) ^(1,2)		0.2	
t _{SK(t)}	Output Skew (different pkg.) ^(1,2)		0.55	
F _{IN}	Input Frequency ^(1,2)		133	MHz

Notes:

- Other loading condition is described on page 4, “Test Circuits for All Outputs.”
- These parameters are guaranteed by design.
- Minimum propagation delay of 1.5ns is guaranteed by design.

Switching Waveforms

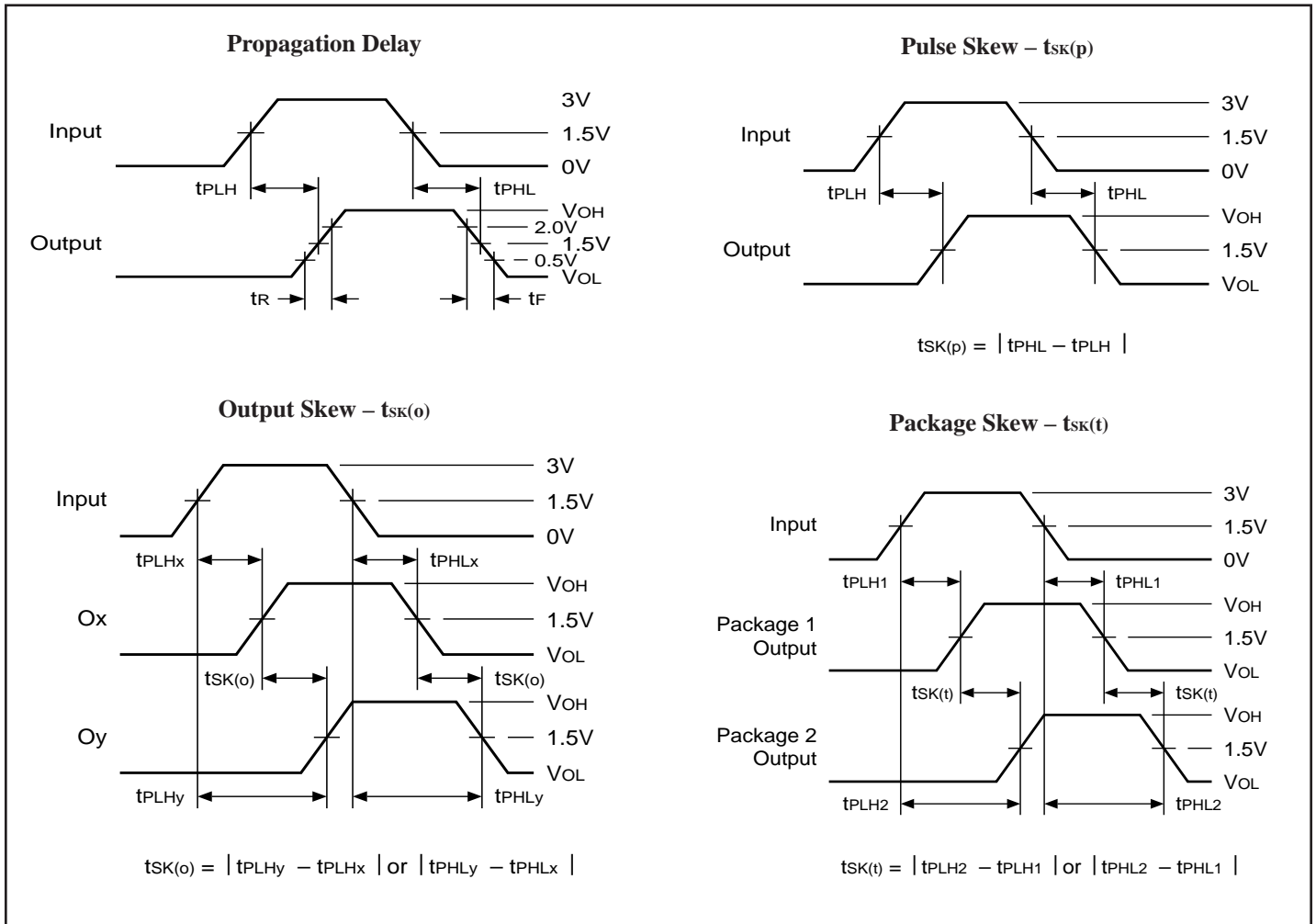

Tests Circuits for All Outputs

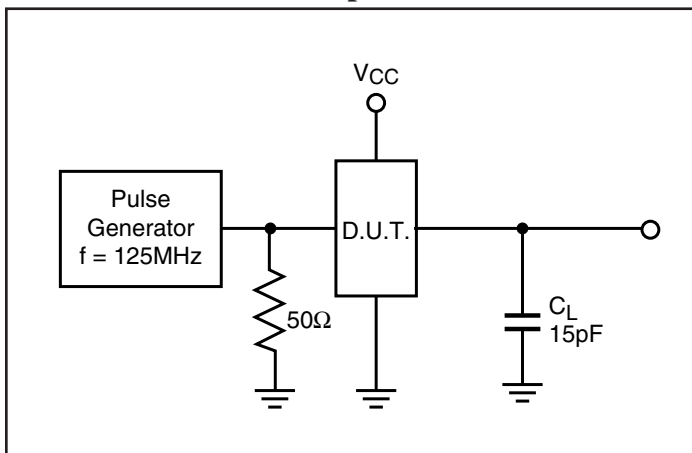

Packaging Mechanical: 16-pin QSOP (Q)

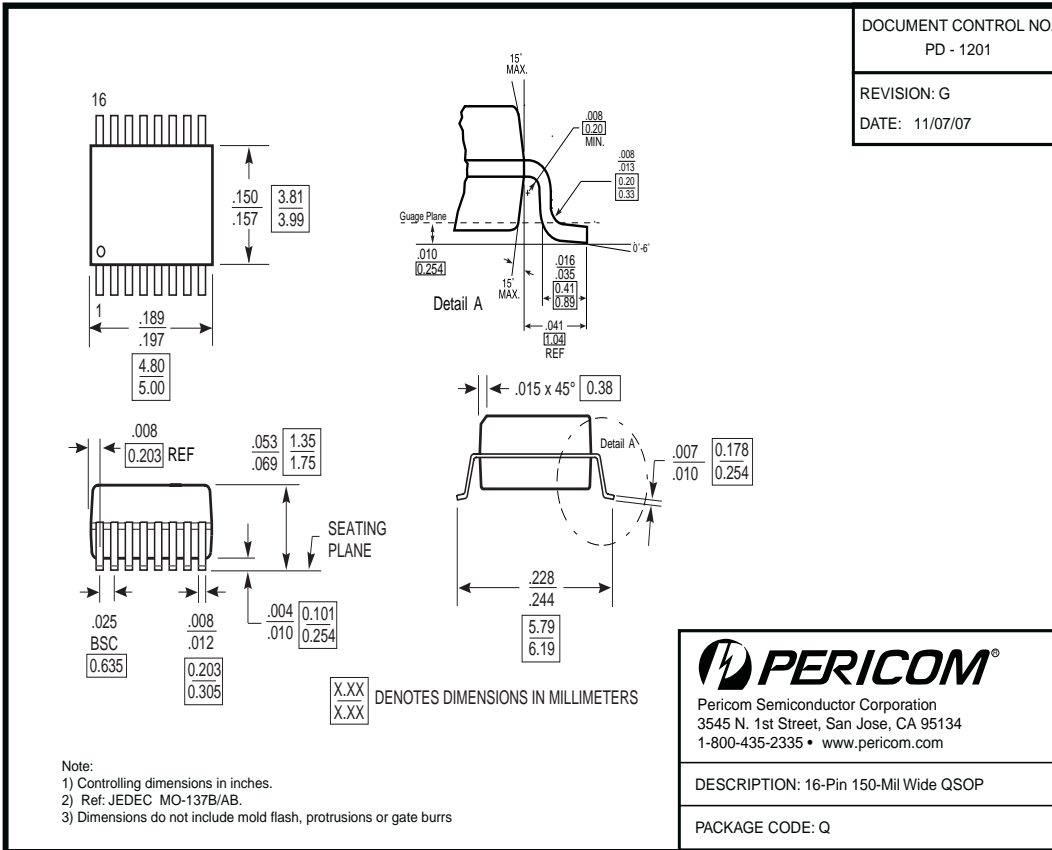

Packaging Mechanical: 16-pin TSSOP (L)

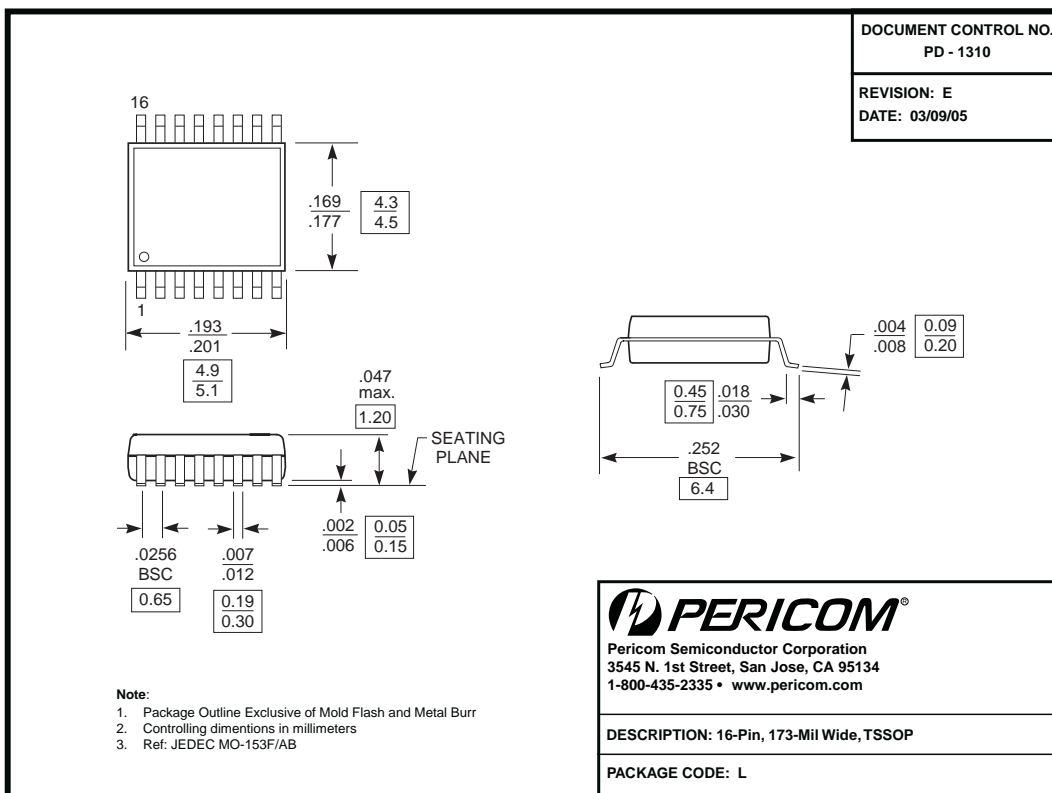

Ordering Information

Ordering Code	Packaging Code	Package Type
PI49FCT32802QE	Q	Pb-free and Green, 16-pin, 150-mil QSOP
PI49FCT32802LE	L	Pb-free and Green, 16-pin, 173-mil TSSOP
PI49FCT32803QE	Q	Pb-free and Green, 16-pin, 150-mil QSOP
PI49FCT32803LE	L	Pb-free and Green, 16-pin, 173-mil TSSOP

Notes:

1. Thermal characteristics can be found on the company web site at www.pericom.com/packaging/